

ASSEMBLY INSTRUCTIONS

Bar Cart

ASSEMBLY
REQUIREMENTS

Assembly Time
(Approximate) 30 Minutes

2-Person
Assembly

Thank you for purchasing our product!

Please refer and use this assembly instruction to assemble the product.

We appreciate your business!

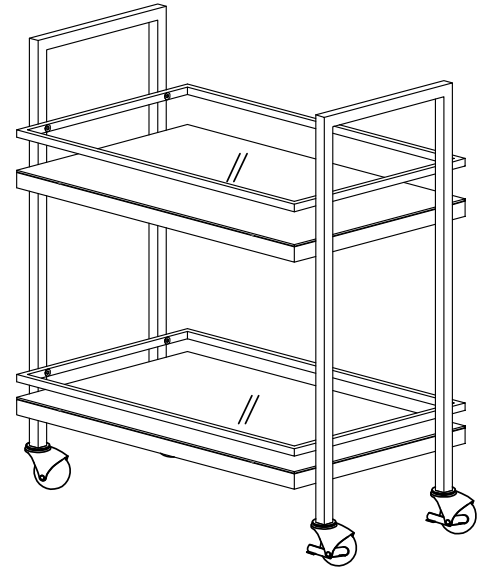

ASSEMBLY PREPARATION

1. Remove all packaging materials, staples and packing straps from the carton.
2. Refer to Parts List and Hardware List, and ensure parts and hardware are complete before assembly. Contact customer service for missing parts.
3. Place all wooden parts on a clean, flat and soft surface (e.g. carpet or rug) to prevent parts from getting scratched.

SAFETY PRECAUTION

1. KEEP ALL HARDWARE PARTS OUT OF REACH OF CHILDREN.
2. DISPOSE PLASTIC PACKAGING MATERIAL IMMEDIATELY TO AVOID ANY RISK OF SUFFOCATION TO CHILDREN AND ANIMALS.

TIPS FOR ASSEMBLY

1. Allow ample room for assembly and in close proximity to where product will be placed.
2. Assemble the product on a surface that does not scratch or damage the exterior gloss and finish of the furniture.
3. Identify all of the parts, hardware and quantities required for each step.
4. During assembly, do not over-tighten any fittings as this may cause damage.
5. DO NOT USE POWER TOOLS TO ASSEMBLE THIS PRODUCT.
6. Always place the product on a flat, level surface.
7. Do not sit or stand on the partially assembled product; only use the product for which it is intended.

CARE AND MAINTENANCE







- Use a slightly damp cloth to clean the product. Do not use bleach or abrasive cleaning material.
- Check all the fittings periodically and re-tighten as necessary. Do not use the product if any of the parts is damaged or broken.
- Never allow any kind of liquid to remain on your furniture. Absorption can cause wood to warp or delaminate.
- Do not place hot items (e.g. hot drinks) directly onto the wood surface.
- Do not drag and/or pull the furniture.

This product is for indoor and household use only - not for commercial use.

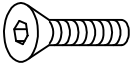

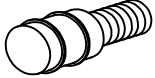
ASSEMBLY INSTRUCTIONS

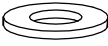
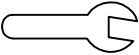
Bar Cart

HARDWARE LIST

ITEM	DESCRIPTION	PART	QTY	ITEM	DESCRIPTION	PART	QTY
A	Bolt		16pcs	E	Caster		2pcs
B	Glass Support		8pcs	F	Allen Key		1pc
C	Washer		4pcs	G	Wrench		1pc
D	Caster With Brake		2pcs				

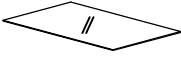
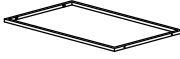
PARTS LIST

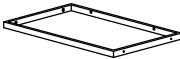
ITEM	DESCRIPTION	PART	QTY	ITEM	DESCRIPTION	PART	QTY
1	Left & Right Frame		2pcs	4	Glass Top		1pc
2	Top Frame		2pcs	5	Mirror		1pc
3	Bottom Frame		2pcs				

PARTS ASSEMBLY OVERVIEW

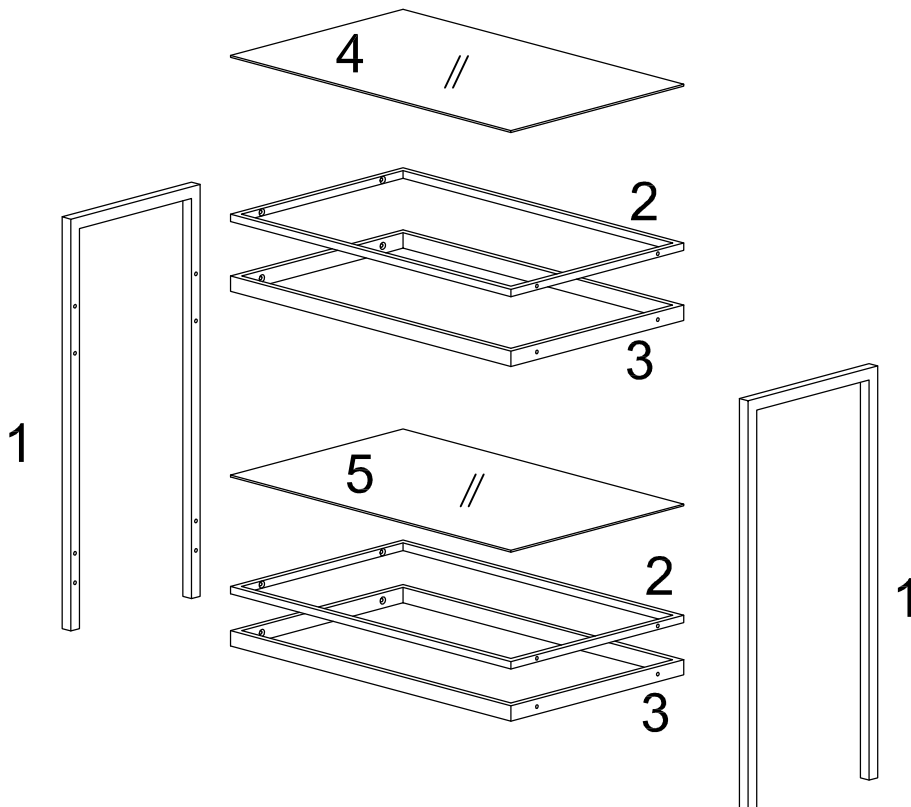

STEP 1

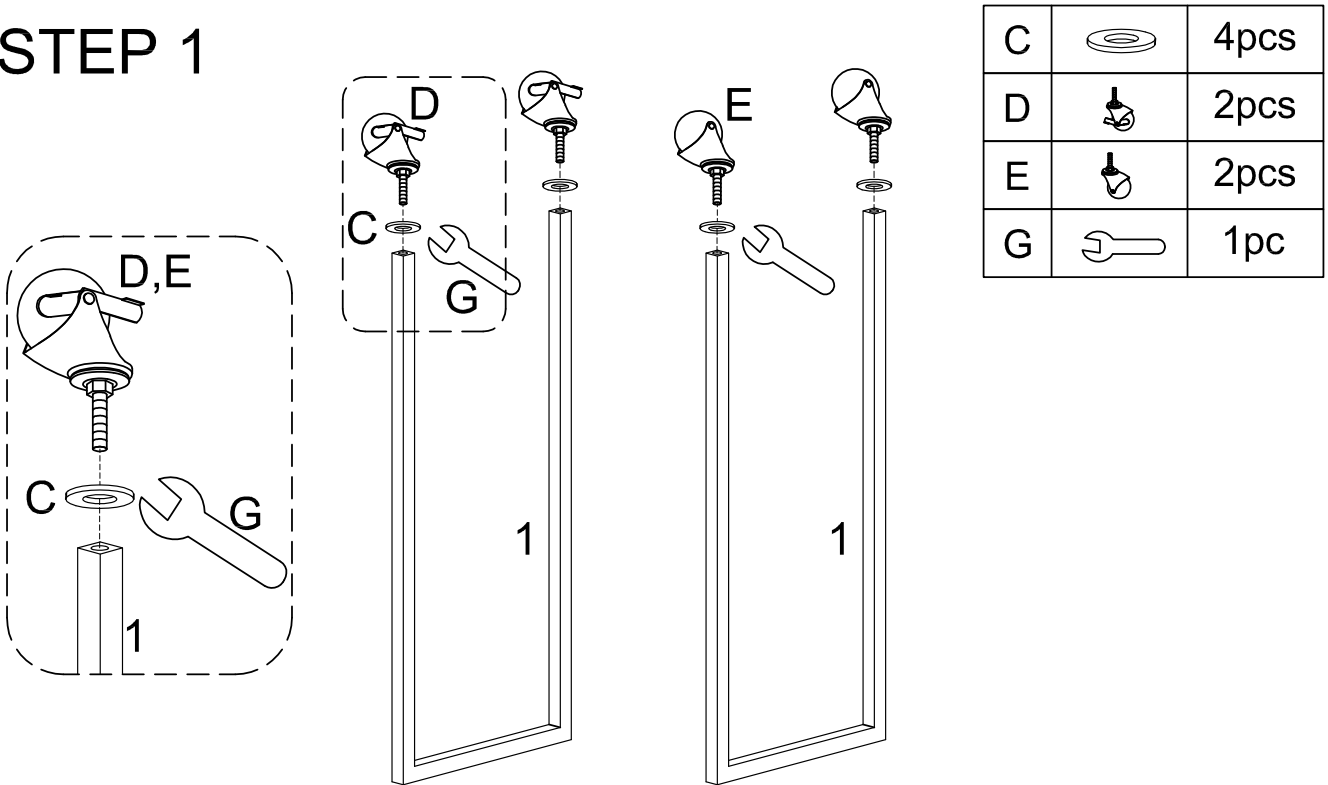

Place a Side Frame (1) with the bolt holes facing up as shown. Use Wrench (G) to tighten Caster via Hex Nut on stem of Caster.

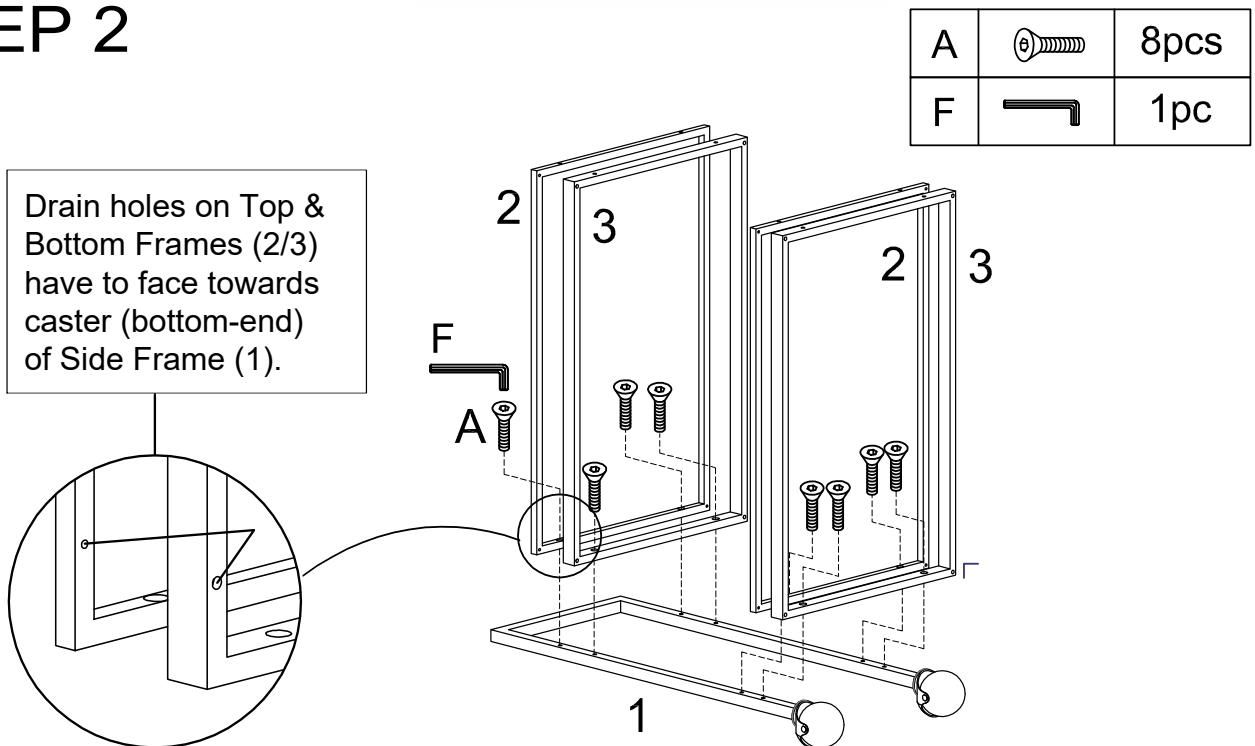

STEP 2

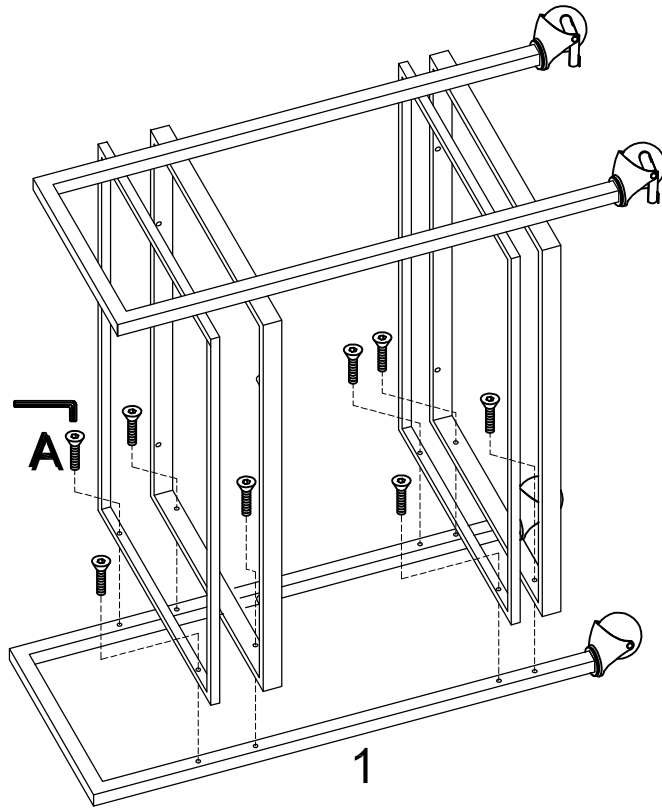

- Place a Side Frame (1) with the bolt holes facing up as shown.
- Position Top and Bottom Frame (2 & 3) as shown (note the direction of the "drain holes" on (2 & 3) face towards the caster).
- Align bolt holes on (2 & 3) to the respective bolt holes on (1), and fasten with Bolt (A). Use Allen Key (F) to tighten (A). Do not tighten (A) completely until all the bolts are in place.

STEP 3



A		8pcs
F		1pc

Fasten the second Side Frame to Top and Bottom Frame (2 & 3) with Bolt (A). Do not tighten (A) completely until all the bolts are in place.
Next, set the cart right-side up.

STEP 4

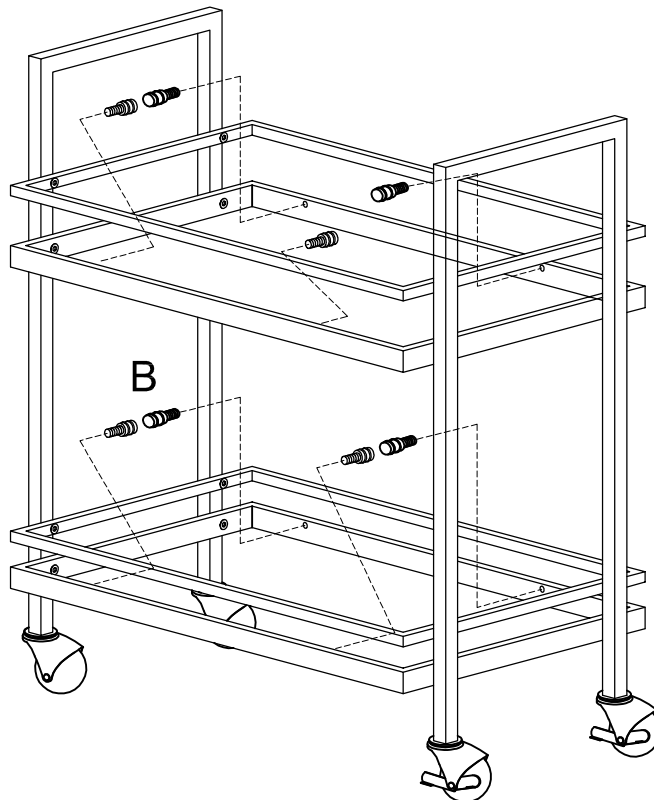

B		8pcs
---	---	------

Screw in the Glass Support (B) into designated holes on Bottom Frame (3).

STEP 5

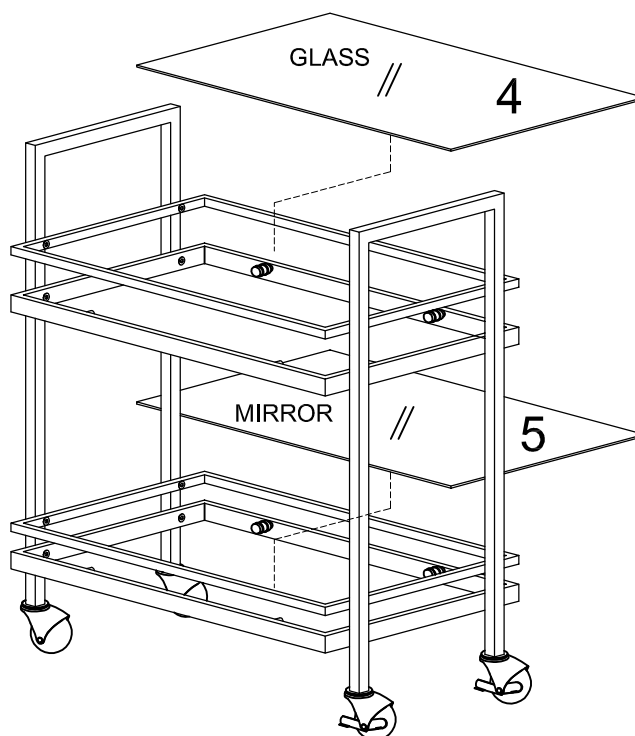

Place Glass Top (4) and Mirror (5) on Glass Support (B).

The assembly of the cart is complete.
