

# PLUS Corner Shelf

with Support Rail

## Technical Data Sheet

### Product Specification

The product shall be a combination corner shelf and grab rail. The product shall have flange covers that conceal the mounting hardware. All components of the product shall be constructed of #304 stainless steel, suitable for use in wet environments. The grab rail portion of the product shall be 1.25" / 3.2cm in diameter. The product shall have a weight capacity of 500lbs / 227kg. Product shall comply with ADA Guidelines, specifying the structural strength of grab bars, tubs and shower seats. The grab rail shall be HealthCraft model PLUS-CS-\_\_\_\_ (see table below for appropriate product code).



### Key Features

- 2-in-1 Bathroom Accessory with with Integrated Support
- Solid Construction and Mounting
- Suitable For Use in a Wet Environment
- 500lbs / 227kg Weight Capacity \*ADA Compliant

### Codes and Standards

- ADA 609.2 Cross Section
- ADA 609.8 Structural Strength



### Specified Model

Model	Finish	Material
PLUS-CS-BLK	Matte Black	#304 Stainless Steel
PLUS-CS-BS	Brushed	
PLUS-CS-CP	Polished Chrome	

# PLUS Corner Shelf

with Support Rail

## Technical Data Sheet

### Product Dimensions

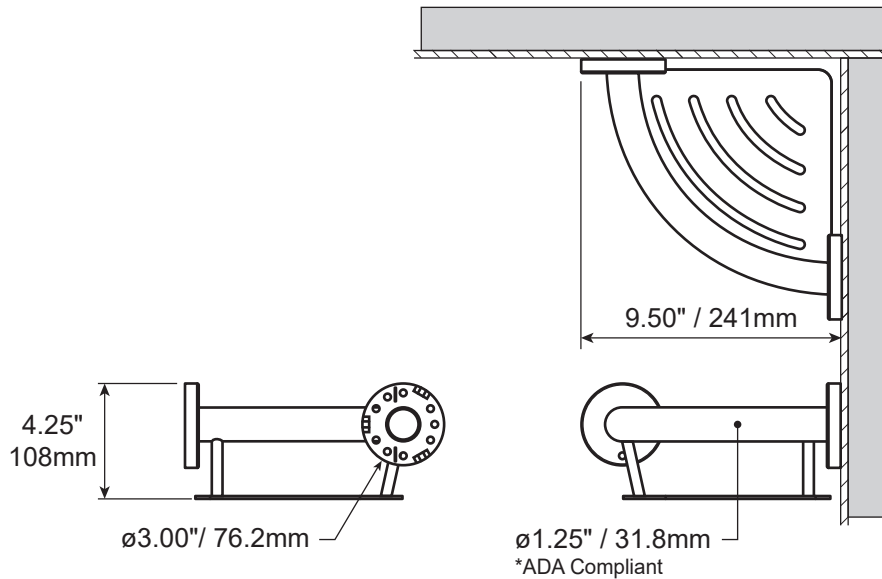

### Shipping Dimensions

Model	Height (H)	Width (W)	Depth (D)	Weight
CS	4.72" / 12.0cm	10.0" / 25.5cm	10.0" / 25.5cm	2.15lbs / 0.98kg

