

DECORATIVE LIGHTING
LUMINAIRE DÉCORATIF

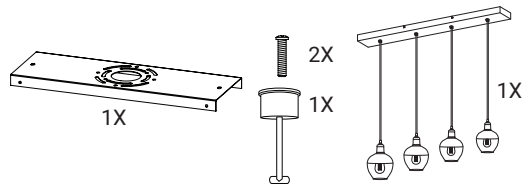

LIGHT SOURCE (INCLUDED)
SOURCE LUMINEUSE (INCLUSE)



REQUIRED TOOLS
OUTILS REQUIS

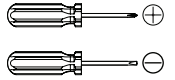

Installation Instructions
Instructions d'installation

! WARNING - ATTENTION

Luminaires must be installed by a certified electrician. Check with local and national codes for proper installation. To prevent electrical shock, disconnect electrical supply before installation or servicing.
Les luminaires doivent être installés par un électricien certifié. Vérifier les normes et les codes du bâtiment de votre région. Pour réduire les risques d'électrocution lors de l'installation ou de l'entretien, couper l'alimentation électrique.

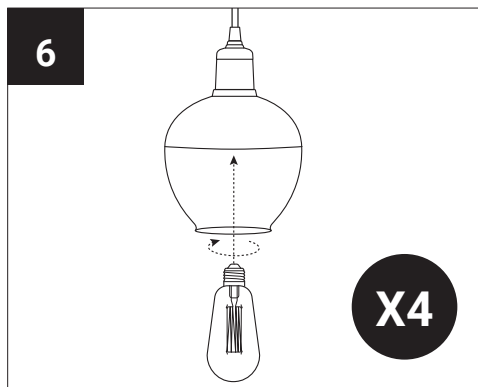
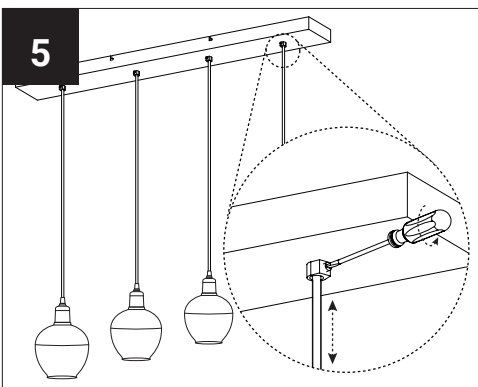
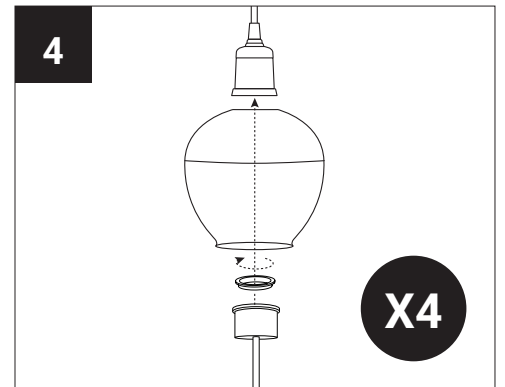
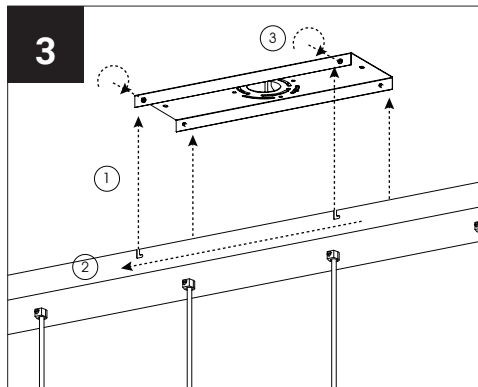
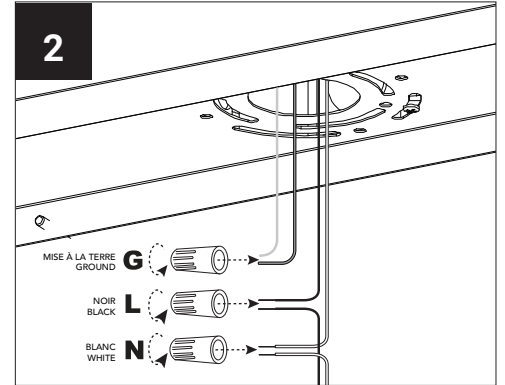
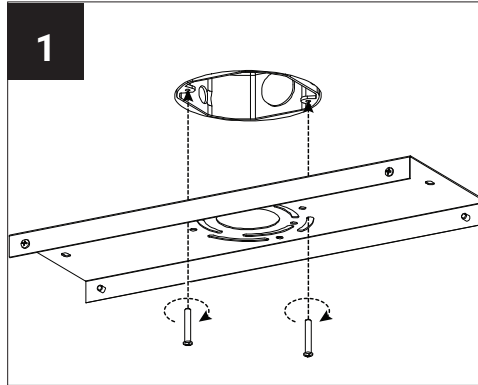
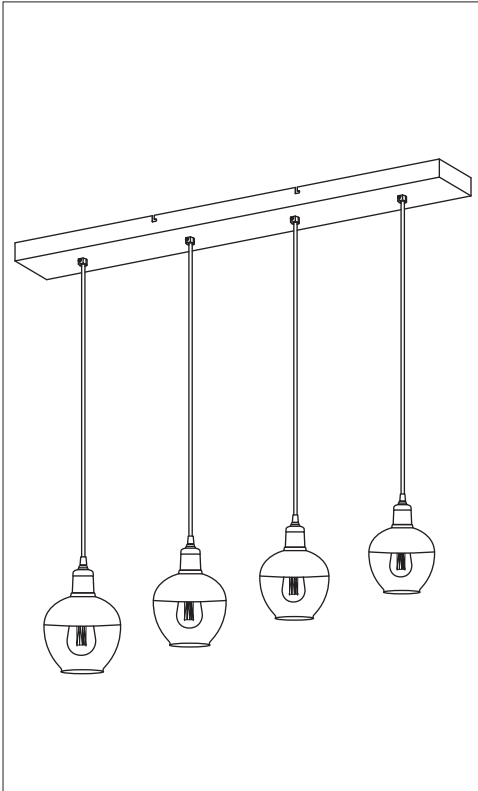

WARRANTY
Our warranty applies to manufacturing defects affecting its products which existed at the time of the purchase of the product, that are non-apparent, and are unknown to the buyer, for a period of 1 year. This warranty applies to the product only and does not cover the installation of the product. The warranty does not apply to material, economic, and/or physical damages or losses caused by the product. This warranty will not apply to any damages and/or losses caused by an incorrect use, installation or maintenance of the product. The manufacturer is therefore not liable for damages to the product or material, economic and/or physical damages or losses caused by an incorrect use, installation or maintenance of the product. If the buyer considers that the product is affected by a defect, the buyer should return the product to the point of purchase or send an email to us. Should the buyer decide to send an email to us, a description of the alleged problem should be included in the email and a proof of purchase as well as the picture clearly illustrating the alleged defect should be attached to the email. The buyer should also return the product to us at his/her own expense. After product inspection, if the warranty applies, we will repair or replace the product free of charge.