

Assembly Instruction

Model:

Mattress Size: for all size

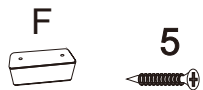
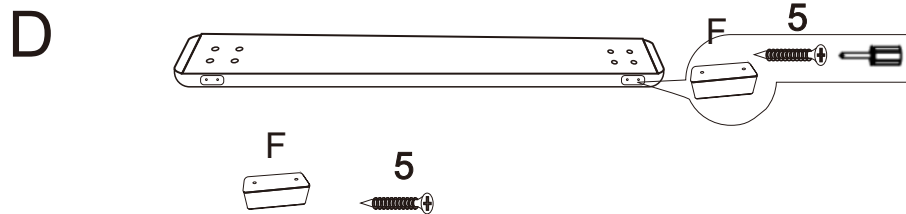
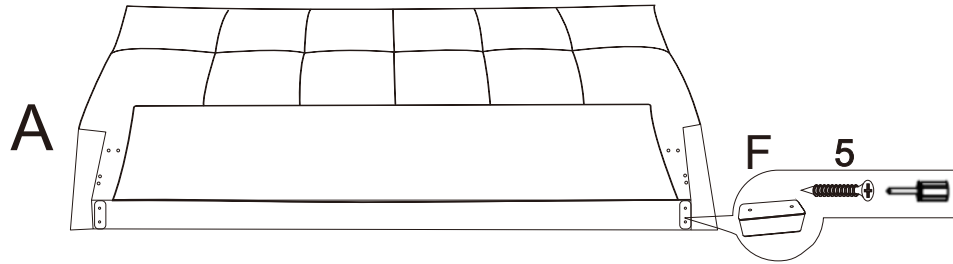

step 1

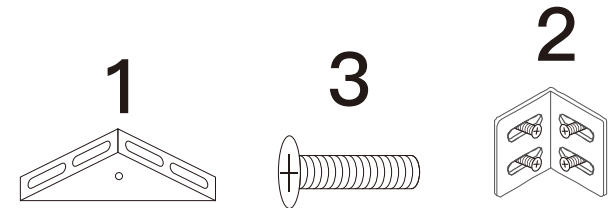
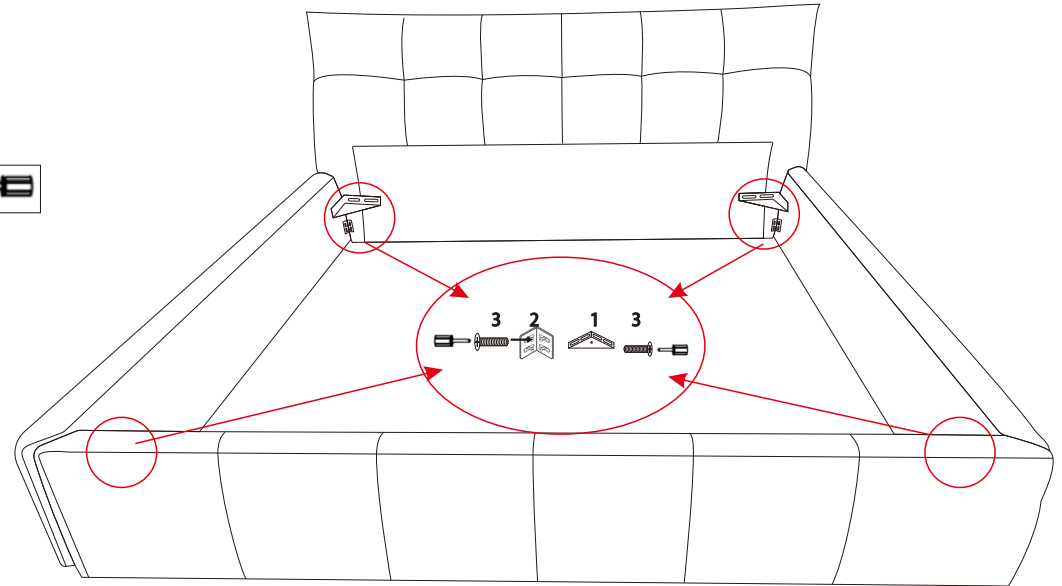

step 2

Assembly Instruction

Model:

Mattress Size:for all size

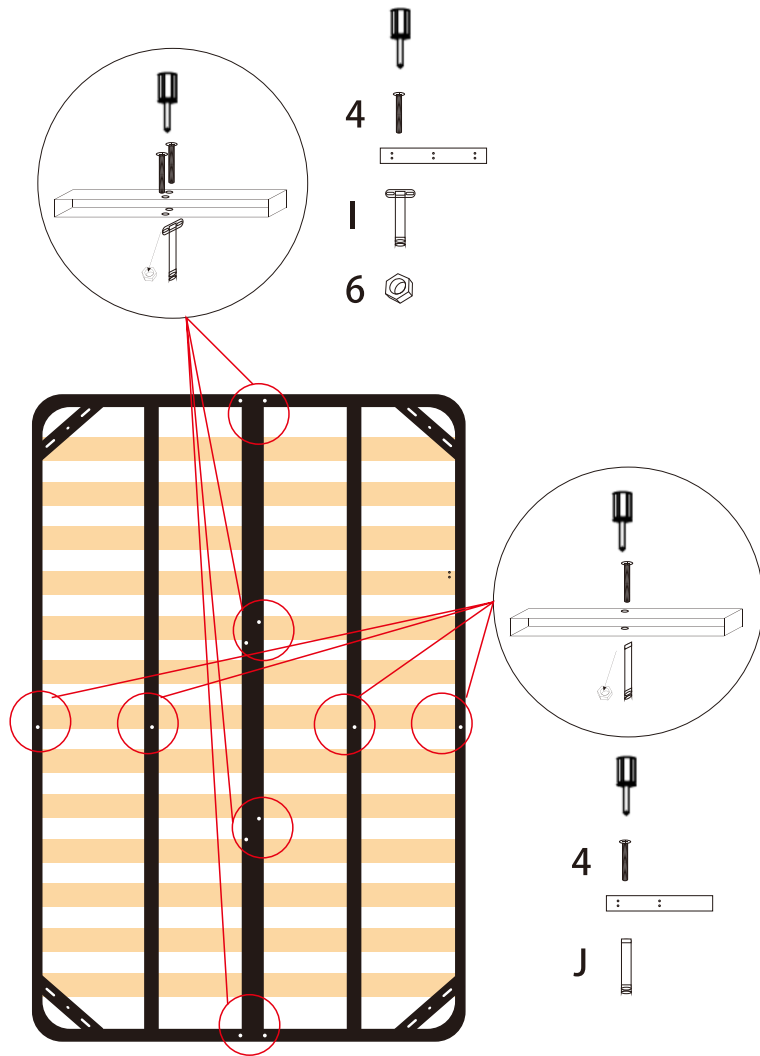

step 3

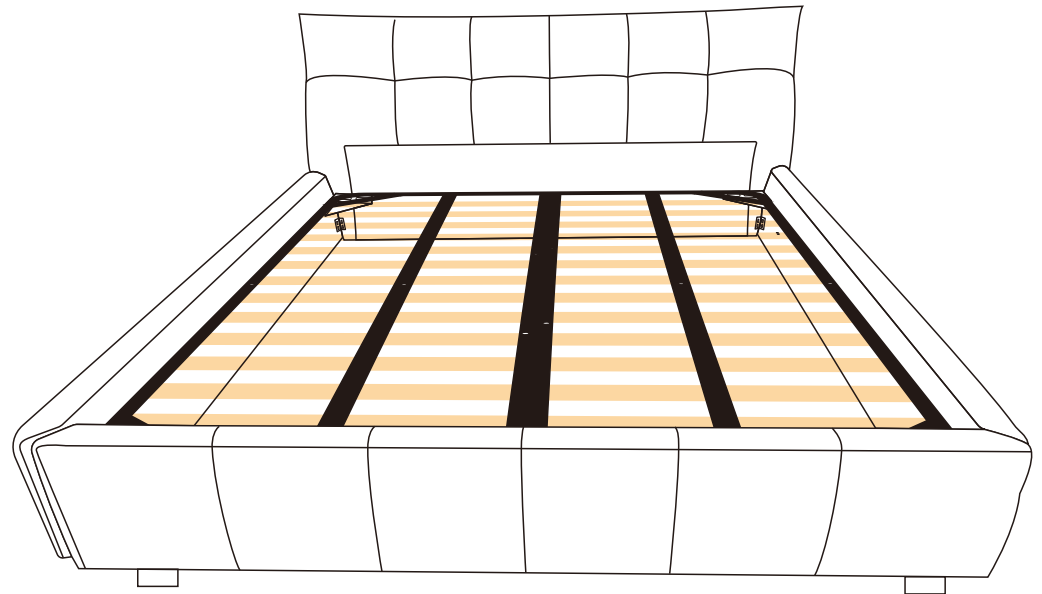







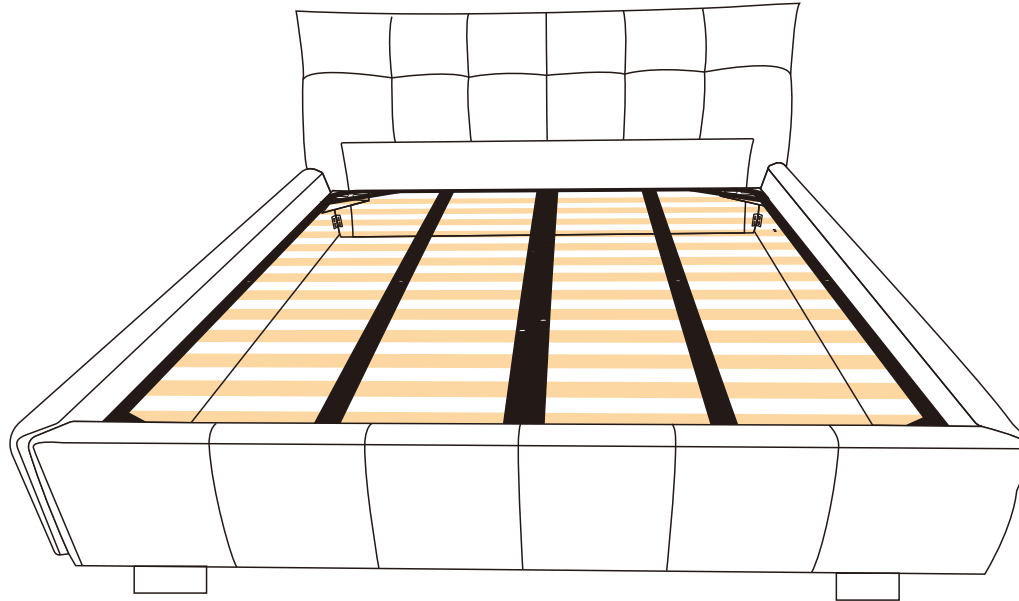

step 4



Assembly Instruction

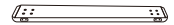

Model:

Mattress Size:for all size

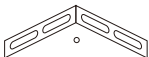

NO.:	PARTS LIST		QTY
A	HEADBOARD		1 PC
B	LEFT BED BOARD		1 PC
C	RIGHT BED BOARD		1 PC
D	FOOTBOARD		1 PC
E			
F	SQUARE FOOT		2 PC
G	SLAT		1 PC
H			
I	SUPPORT LEG 230 mm		4 PCS
J	SUPPORT LEG 230 mm		4 PCS

NO.:	HARDWARE PE	QTY
1	BIG BRACKET 	4 PCS
2	SMALL BRACKET 8*10mm 	4 PCS
3	SCREW 8*25 MM 	32 PCS

NO.:	HARDWARE LIST	QTY
4	SCREW 8x50 MM 	12 PCS
5	SCREW 30 MM 	24+3 PCS
6	NUT 	8 PCS

Remark:Phillips head screw driver is required in the assembly process; however, manufacturer does not provide this item.