

NOTICE

- *Please make sure that you have all parts indicated and they are in good condition before you begin assembly of this item. Refer to part list and hardware list below for guidance.
- *This item should be assembled on a soft surface to prevent scratching the finish during assembly.
- *This item may require periodic tightening.
- *If you are having difficulty, our friendly Customer Care team is always here to help. Please email customersupport@safavieh.com











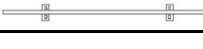

PREPARATION

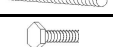
- *Before beginning assembly of product, make sure all parts are present. Compare parts with part contents list and hardware contents list.
- *If any part is missing or damaged, do not attempt to assemble the product.
- *Estimated Assembly Time: 30 minutes.
- *Tools Required for Assembly (included): Allen Key and Wrench

CARE AND MAINTENANCE

- Spot clean using a mild water-free solvent. Only a professional cleaner should undertake a complete overall cleaning.
- The use of steam or water-based cleaners may cause excessive shrinking or staining.

Parts List and Hardware List

| PIECE | DESCRIPTION | PICTURE | QUANTITY | CARTON CALL |
|-------|--------------------------|---|----------|-------------|
| A | Headboard |  | 1X | 1 of 2 |
| B | Footboard |  | 1X | 2 of 2 |
| C | Siderail |  | 2X | 2 of 2 |
| D | Iron Center Support Rail |  | 1X | 2 of 2 |
| E | Iron Slat |  | 5X | 2 of 2 |
| F | Metal Leg |  | 2X | 2 of 2 |
| HW1 | Bolt M8 x 100 mm |  | 8X | 2 of 2 |
| HW2 | Bolt M8 x 20 mm |  | 4X | 2 of 2 |
| HW3 | Bolt M6 x 15 mm |  | 20X | 2 of 2 |
| HW4 | Anchor M8 |  | 8X | 2 of 2 |
| HW5 | Nut M8 |  | 12X | 2 of 2 |
| HW6 | Metal Cap |  | 10X | 2 of 2 |
| HW7 | Plastic Cap |  | 17X | 2 of 2 |
| HW8 | Wrench |  | 1X | 2 of 2 |
| HW9 | Allen Key |  | 1X | 2 of 2 |

SAFAVIEH C O U T U R E

Model# KNT7009

Product Dimensions: 84.30" W x 88.00" D x 56.30" H

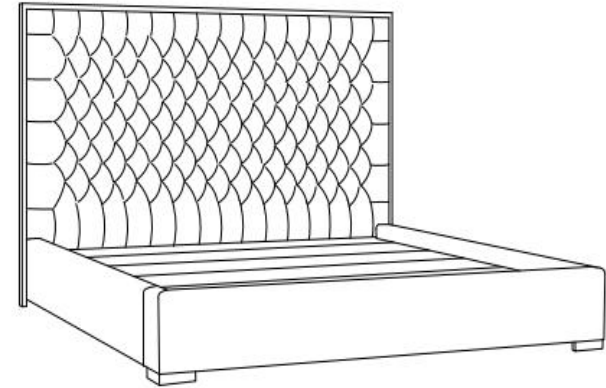

Weight Capacity: 550 lbs

WARNING: DO NOT STAND ON BED

WARNING: DO NOT OVER TORQUE BOLTS

PREPARATION

*Before beginning assembly of product, make sure all parts are present. Compare parts with part contents list and hardware contents list.

*If any part is missing or damaged, do not attempt to assemble the product.

*Estimated Assembly Time: 30 minutes.

*Tools Required for Assembly (included): Allen Key and Wrench

*If you are having difficulty, our friendly Customer Care team is always here to help. Please email customersupport@safavieh.com

1

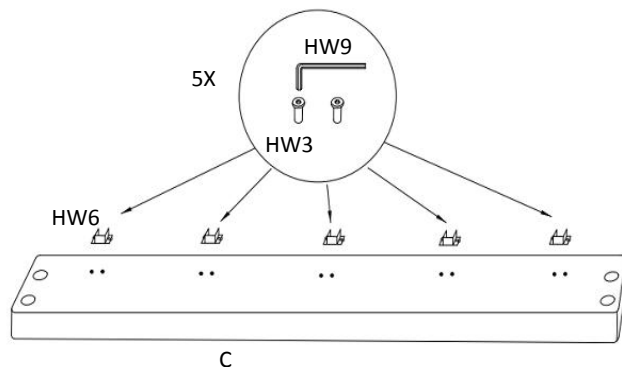

STEP 1: Screw the 5 Metal Caps(HW6) to the one Siderail(C) with 10 bolts(HW3). Repeat the same steps for the other Siderail(C).

2

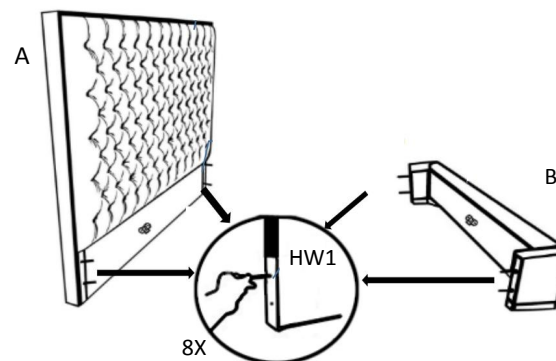

STEP 2: Hand-screw the 8 bolts(HW1) to the Headboard(A) and Footboard(B) .

3

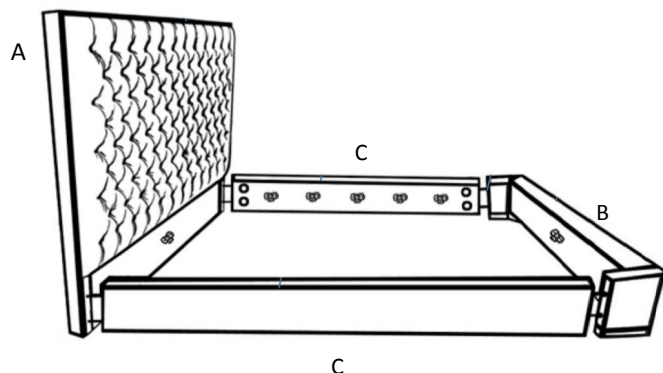

STEP 3: Attach the Siderails(C) to the Headboard(A) and Footboard(B) by guiding the bolts(HW1) through the end holes on the Siderails(C).

4

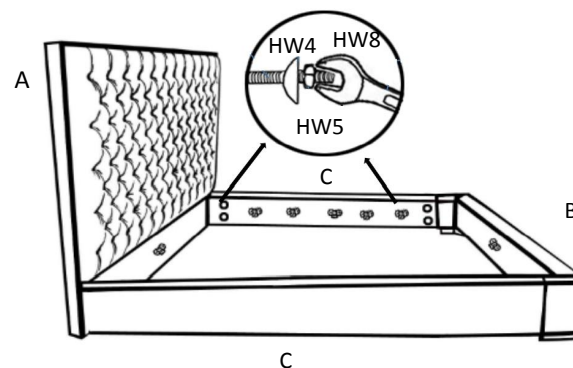

STEP 4: Attach the anchor(HW4) to the bolt(HW1). Then lock the bed by securely tightening the nuts(HW5) to the end of the bolt(HW1) with the wrench(HW8) provided.

PREPARATION

*Before beginning assembly of product, make sure all parts are present. Compare parts with part contents list and hardware contents list.

*If any part is missing or damaged, do not attempt to assemble the product.

*Estimated Assembly Time: 30 minutes.

*Tools Required for Assembly (included): Allen Key and Wrench

*If you are having difficulty, our friendly Customer Care team is always here to help. Please email customersupport@safavieh.com

5

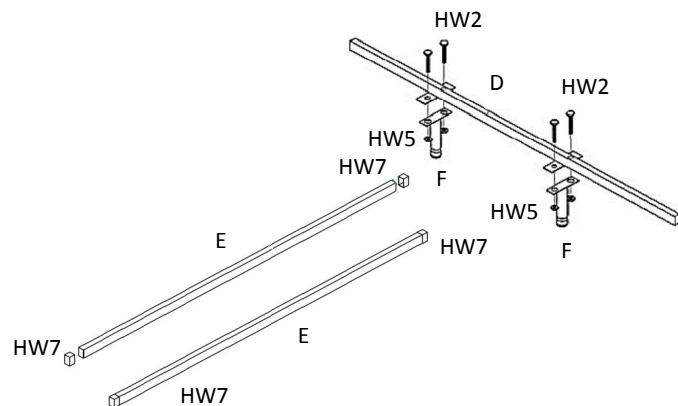

STEP 5: Screw the 2 metal legs(F) onto the long iron center support rail(D). Insert the plastic cap(HW7) in the iron center support rail(D) and 5pcs iron slats(E).

6

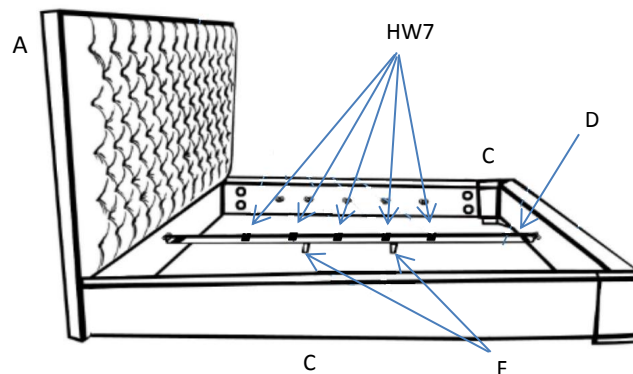

STEP 6: Insert the center support rail(D) in the metal brackets on the Headboard(A) and Footboard(B). Adjust the feet on the metal legs(F) so that they are resting evenly on the floor. Put the plastic cap(HW7) in the center support rail(D) evenly .

7

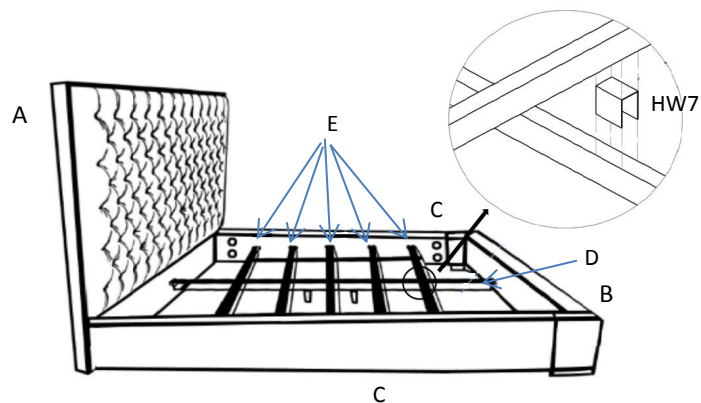

STEP 7: Insert the remaining 5 iron slats(E) horizontally between the left and right Sideboards(C). Make sure the plastic caps(HW7) between the center support rail(D) and each of iron slats(E).

8

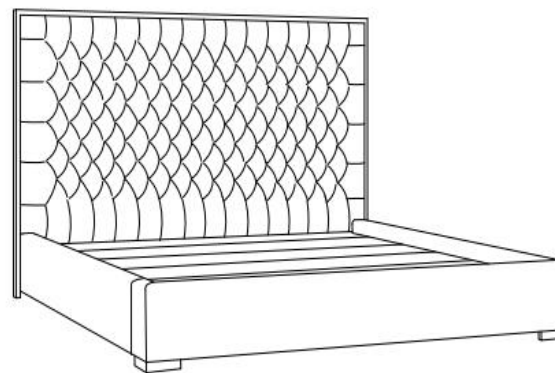

STEP 8: Congratulations on your successful assembly.