

ASSEMBLY INSTRUCTIONS

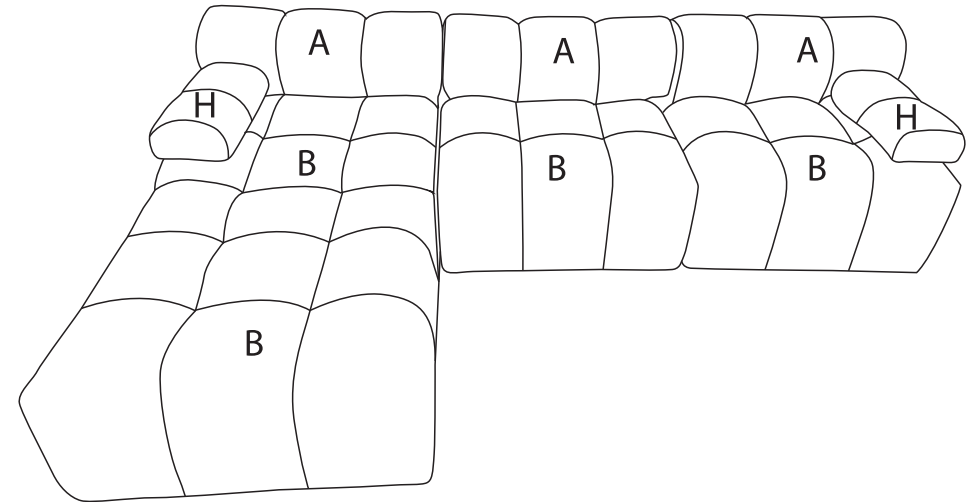

- Your cushions come vacuum packed and sealed for shipping. To restore the cushion's original shape, follow the steps below.



Open the vacuum bag carefully.



Press and tap with both hands from the side to fully inhale air.

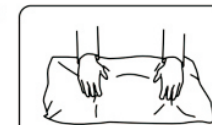



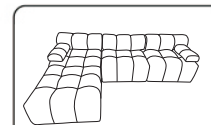





Press and tap with both hands from the front to fully inflate.

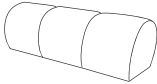

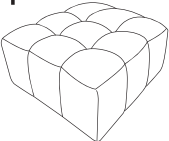
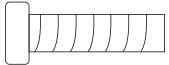
Carefully smooth out each section until the surface is even.

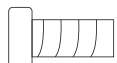
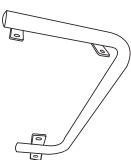
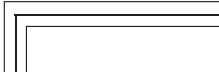
After packing up, place them in somewhere dry and ventilated. After about 48-72 hours, it can be restored to the best use condition.

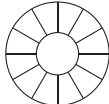
SPARE PARTS

<p>Ax3</p> 	<p>Hx2</p> 
<p>Bx4</p> 	<p>Ix14+1PCS M6x45mm</p> 
<p>Cx6</p> 	<p>Jx36+1PCS M6x25mm</p> 
<p>Dx2</p> 	<p>Kx1</p> 
<p>Ex16</p> 	
<p>Fx8+1PCS</p> 	
<p>Gx4</p> 	

Be sure to keep spare parts.

If screws or nails of a product are damaged or lost, or screws or nails of a subsequent product are damaged or aged, spare parts can be used to replace them.

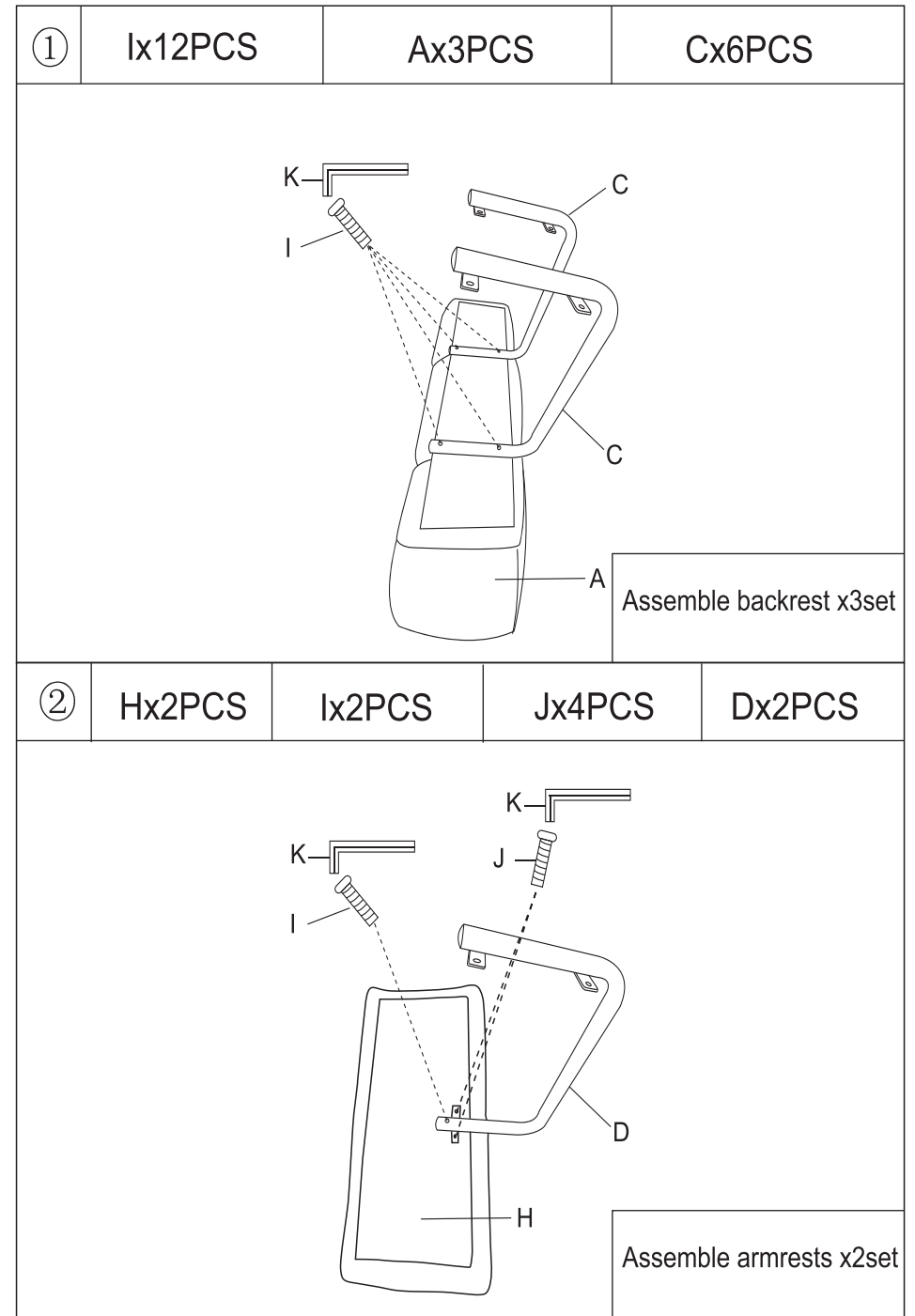
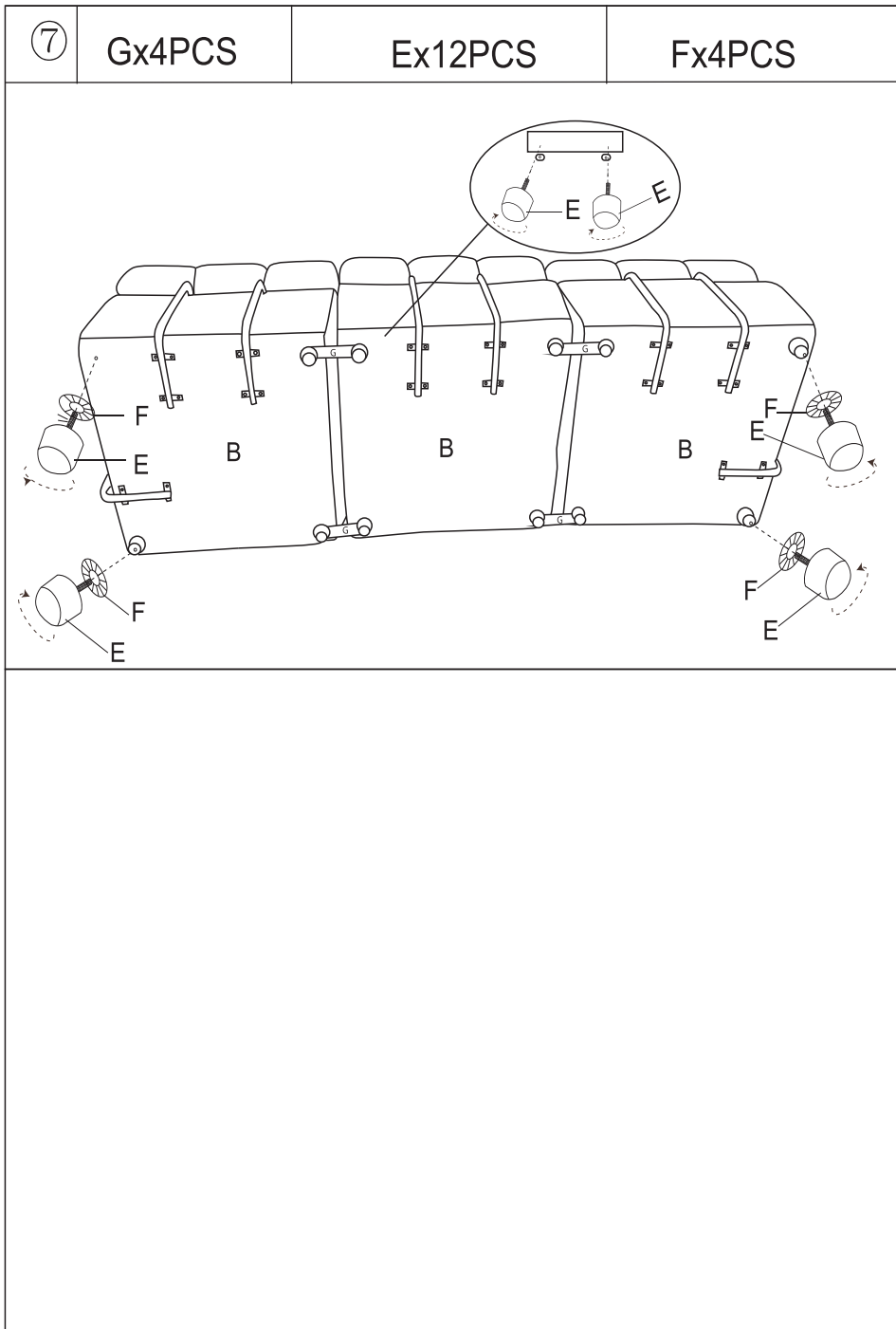

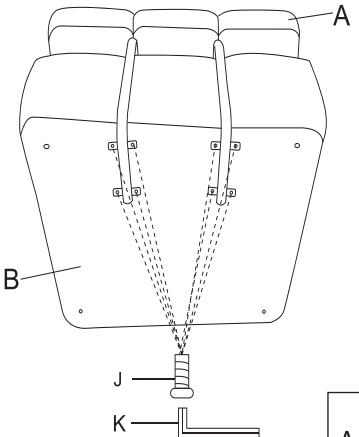
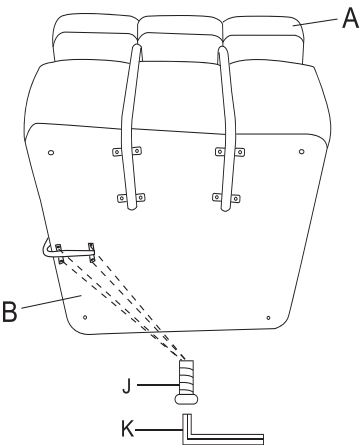
③	Ax3PCS	Bx3PCS	Jx24PCS
			
			Assemble seat x3set
④	Hx1PCS	Bx1PCS	Jx4PCS
			
			Assemble left armrest x1set

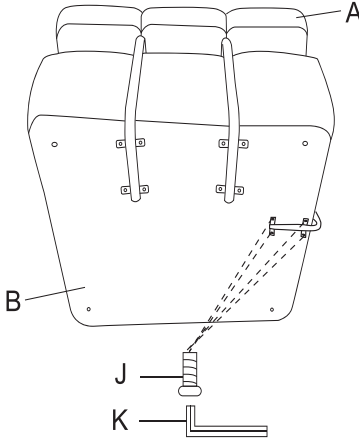
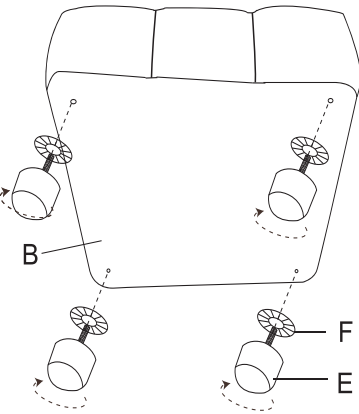
⑤	Hx1PCS	Bx1PCS	Jx4PCS
			
			Assemble right armrest x1set
⑥	Bx1PCS	Ex4PCS	Fx4PCS
			
			Assemble ottoman x1set