

INSTALLATION GUIDE

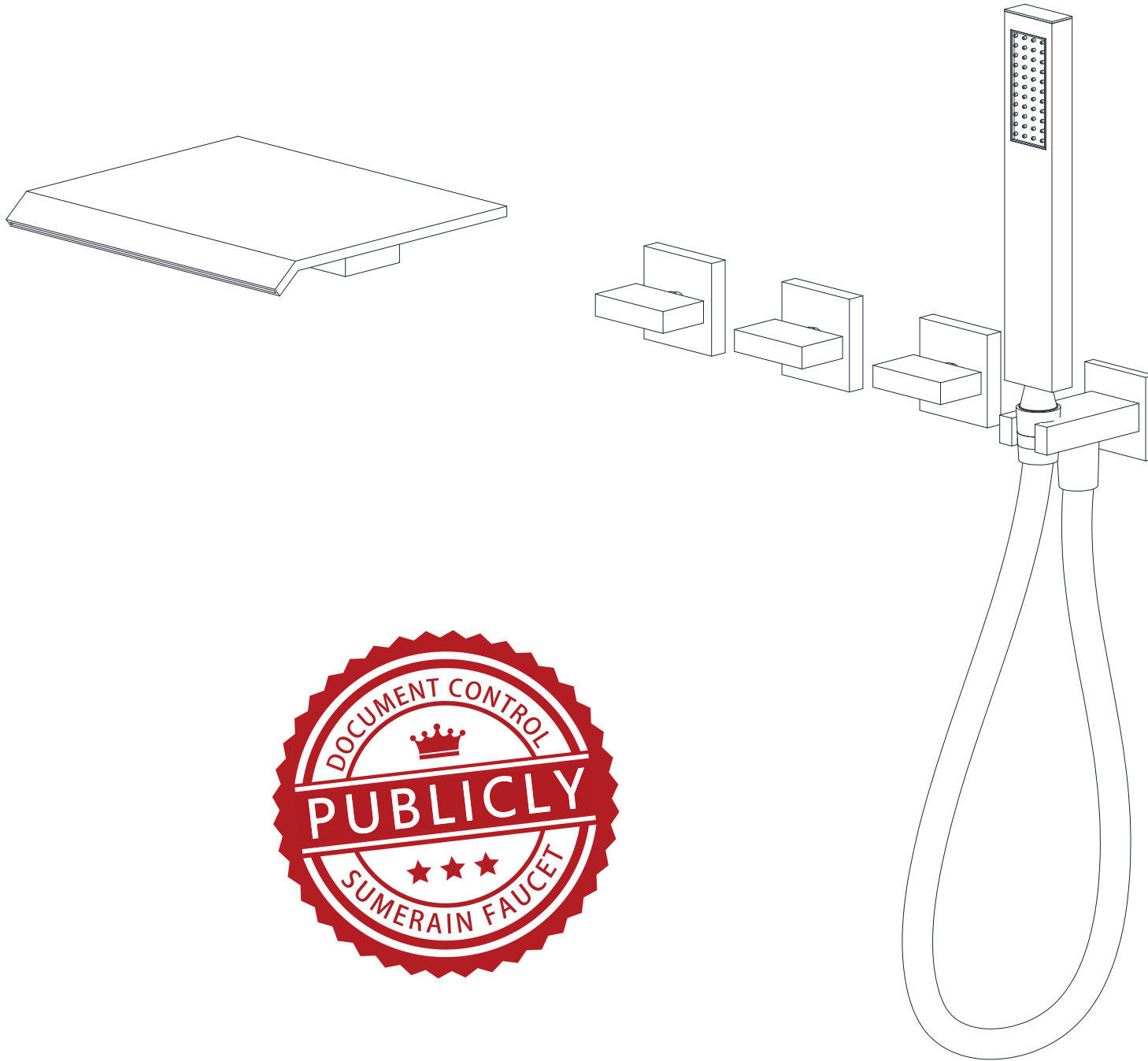

WALLMOUNT WATERFALL TUB FAUCET

MODEL	FINISH
S2129CW	CHROME
S2129NW	BRUSHED NICKEL
S2129GW	BRUSHED GOLD
S2129DW	MATTE BLACK

CUSTOMER CARE LINE: +1-866-203-0866

TOOLS RECOMMENDED

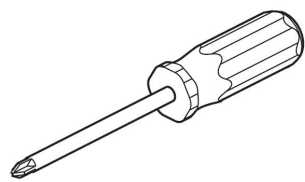

Philips Screwdriver

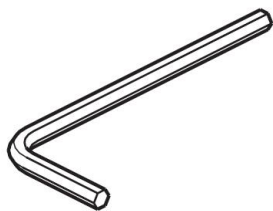

Allen Wrench

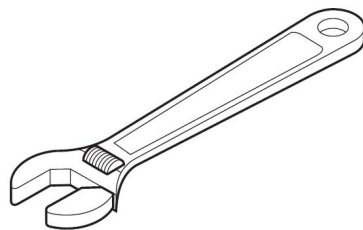

Adjustable Wrench



Channel Locks

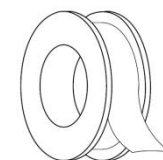

Teflon Tape

1. BEFORE PROCEEDING



WARNING: Before beginning any installation or operation, read all instructions carefully. If you are unsure about installing this product, consult a licensed professional. This product must be installed in compliance with all applicable local and state plumbing and building codes. Professional assistance is strongly recommended.

2. SHUT OFF WATER SUPPLY

Locate the water supply inlets and turn off the corresponding water supply valves, typically located under the sink or near the water meter. If replacing an existing unit, remove the old unit and thoroughly clean the mounting surface to ensure proper installation.

3. CHECKING THE CONTENTS OF THE BOX

Upon opening the box, verify that all the listed components are included.

If any of these items are missing, please contact SUMERAIN consumer service by email to: supports@sumerain.com

4. PLANNING AND INSTALLATION INSTRUCTIONS



Attention: The shower must be installed, flushed, and inspected in accordance with applicable regulations to ensure proper functionality.

The dimensions of the shower setup must be determined individually to fit the installation requirements and comply with applicable guidelines.

- Operating pressure for the control valve:
 - Maximum: 145 PSI.
 - Recommended: 43.5 PSI.
- Maximum hot water temperature: 140°F.

5. INSTALLATION

5.1 Turn on the shut-off valve to flush the hot and cold water supply pipes before connecting them to the valve body. Allow the water to run for 3-5 minutes to remove dirt and debris. Turn off the water supply once flushing is complete.

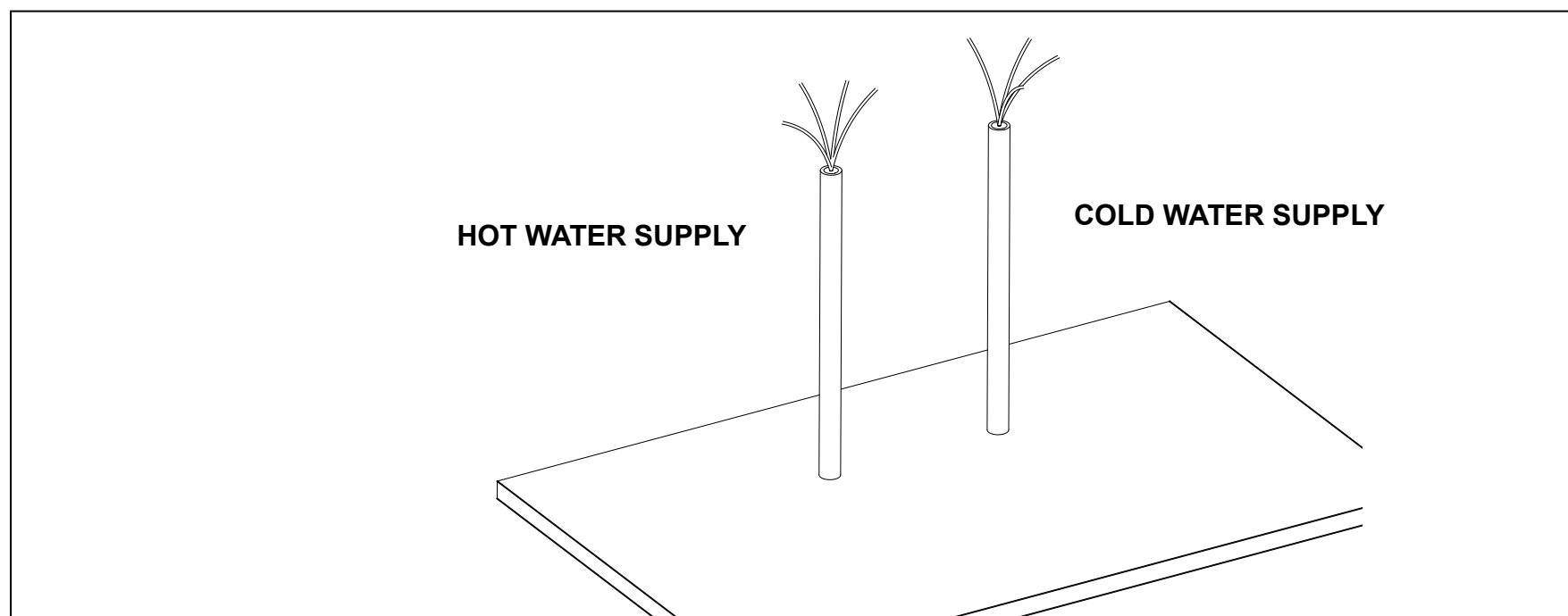

5.2 Construct a wooden mounting rack to secure the rough-in valve assembly. Position the face of the mounting board behind the finished wall surface.

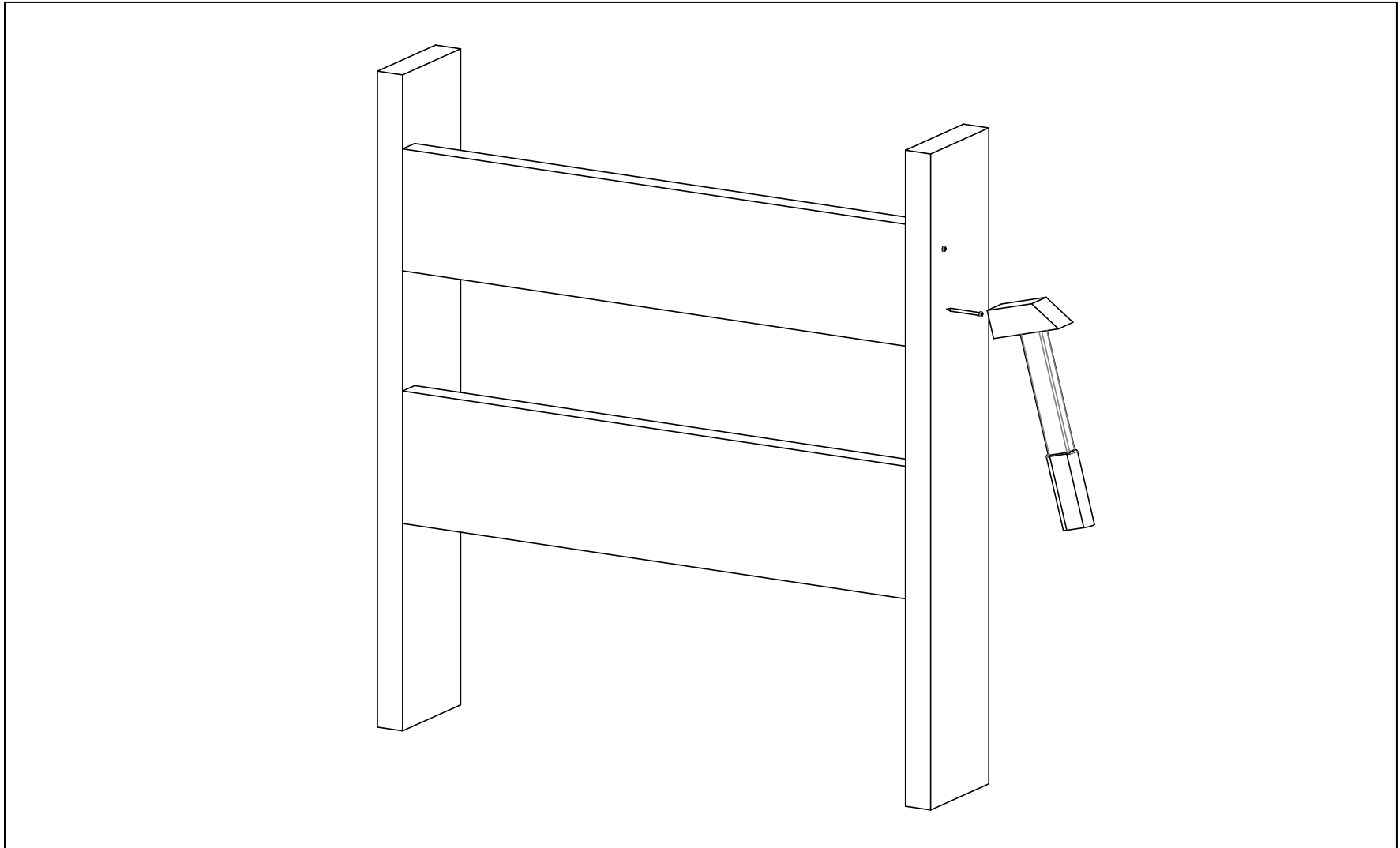

WARNING: Improper installation depth may result in significant rework and additional costs.

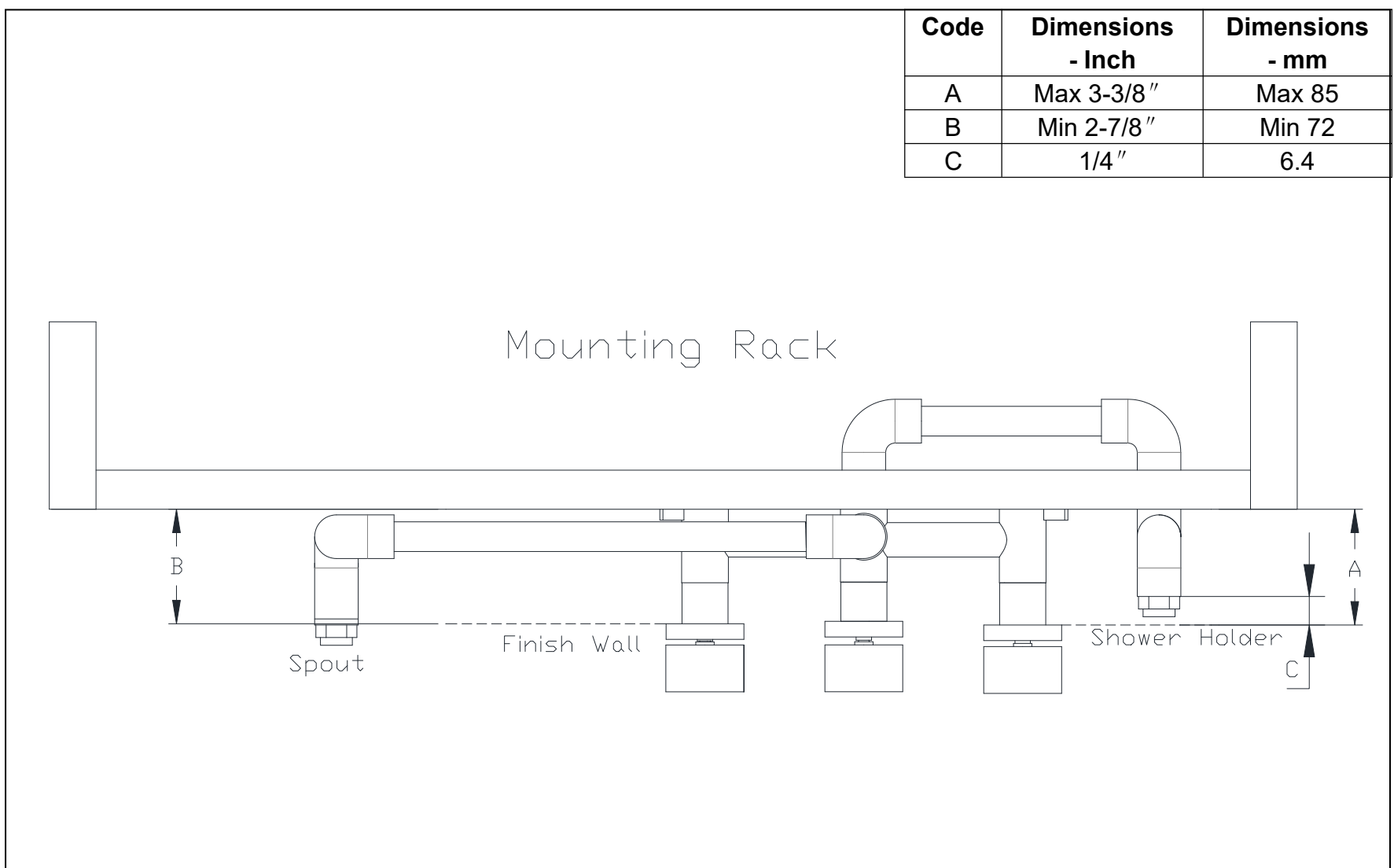

5.3 To prepare for the next step of installation, partially disassemble the rough-in valve. Remove the screw covers from the knobs and use an Allen wrench to loosen the set screws by turning them counterclockwise. Next, remove the knobs and the escutcheons from the rough-in valve.

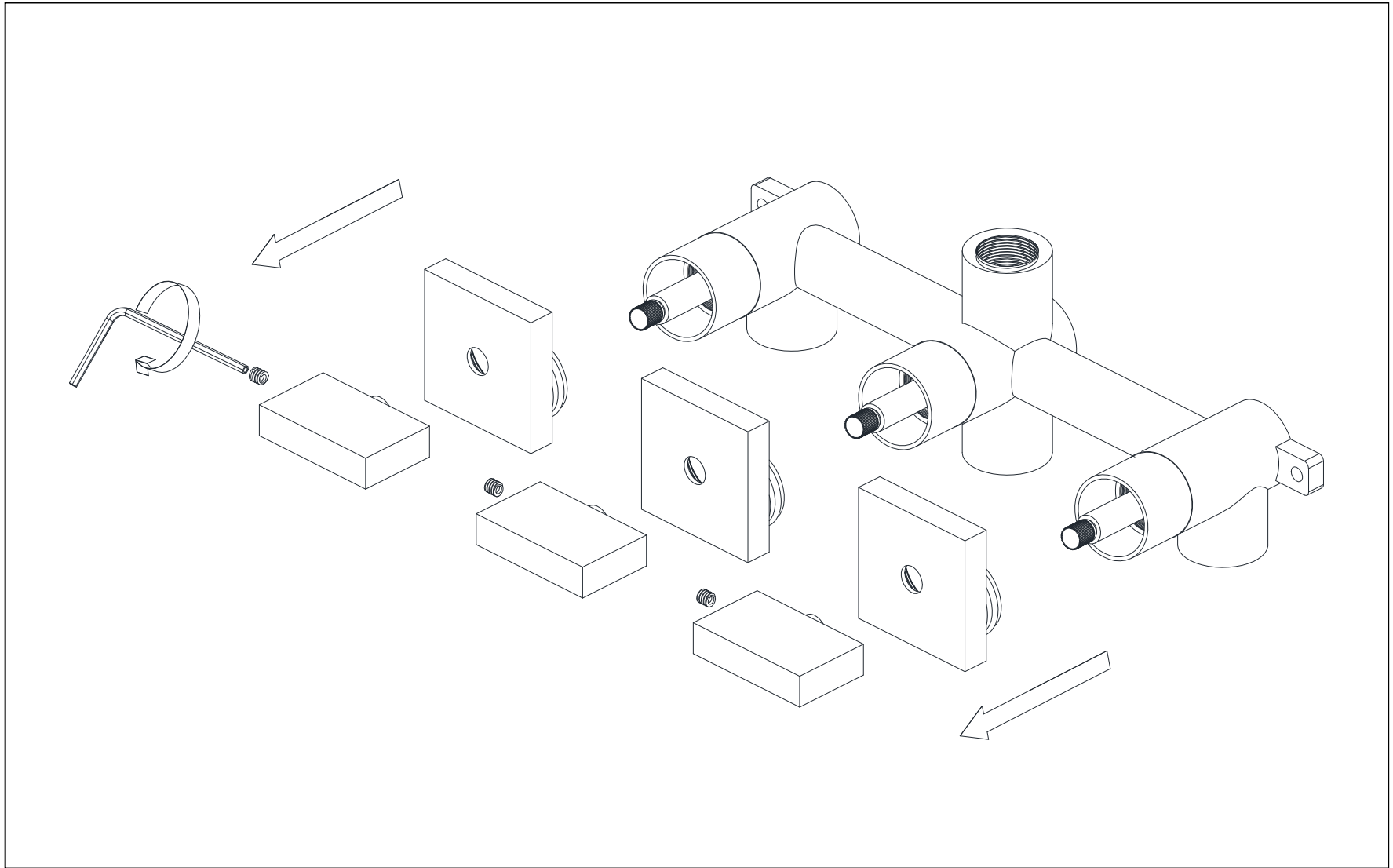

5.4 Secure the rough-in valve assembly to the mounting rack using the screws, ensuring they are tightened securely.

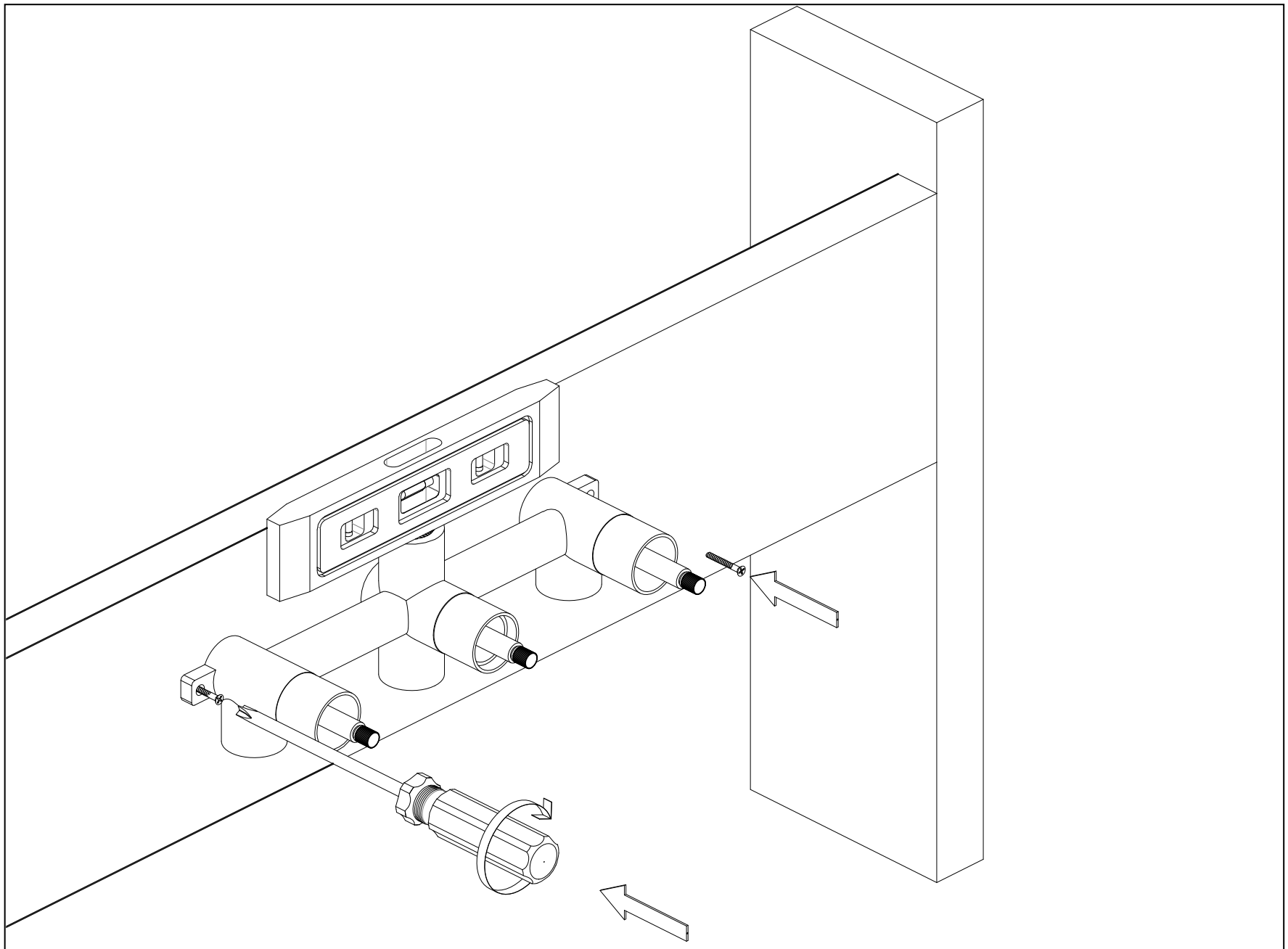

5.5 Apply Teflon tape to the threads of the supply pipe outlet, then connect it to the valve inlet. The rough-in valve connection threads for the hot and cold water inlets are NPT 1/2" [US, CA].

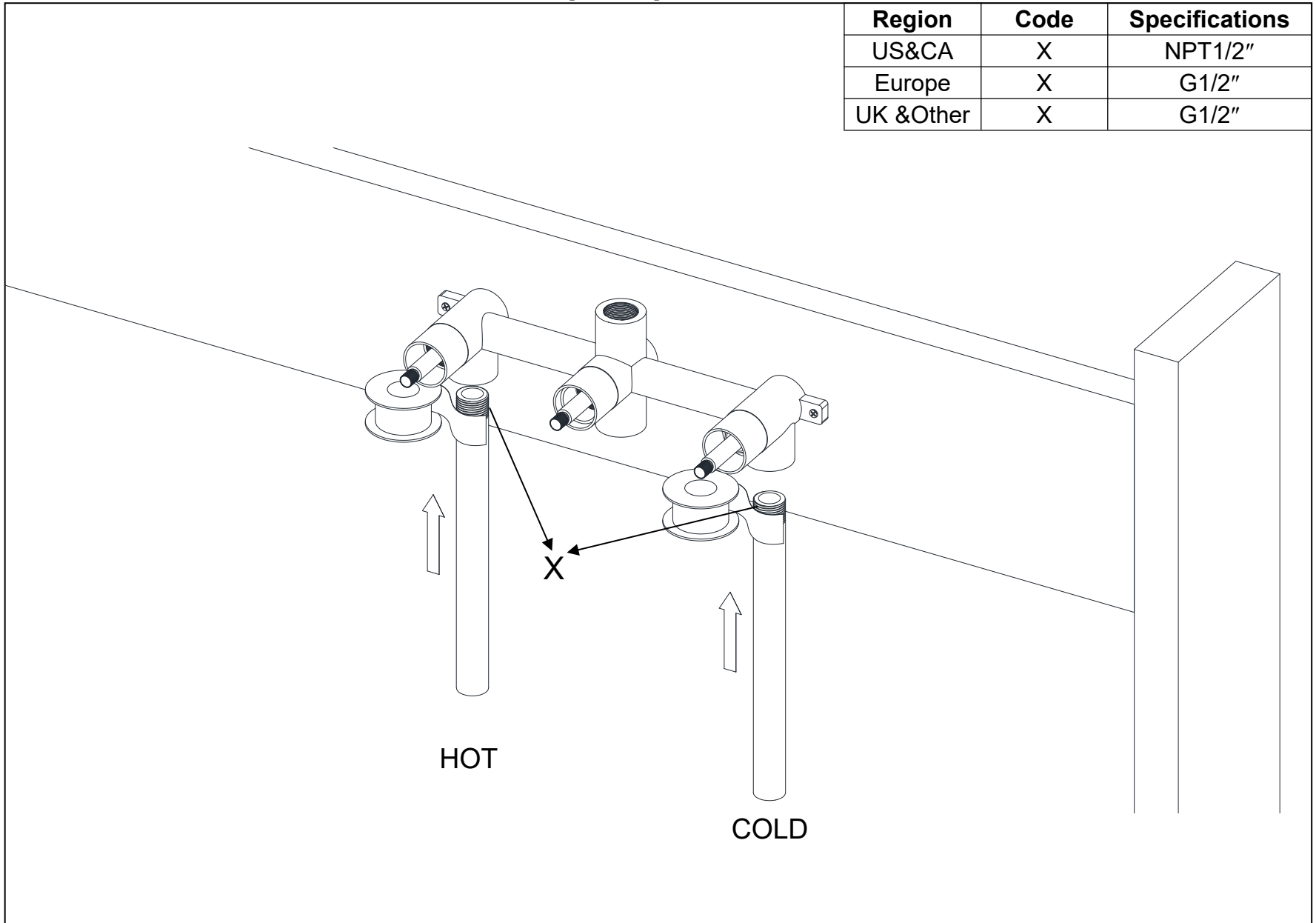

5.6 Install the feed pipe for the spout, ensuring a secure connection. The rough-in valve connection threads at the mixer water outlet are NPT 1/2" [US, CA].

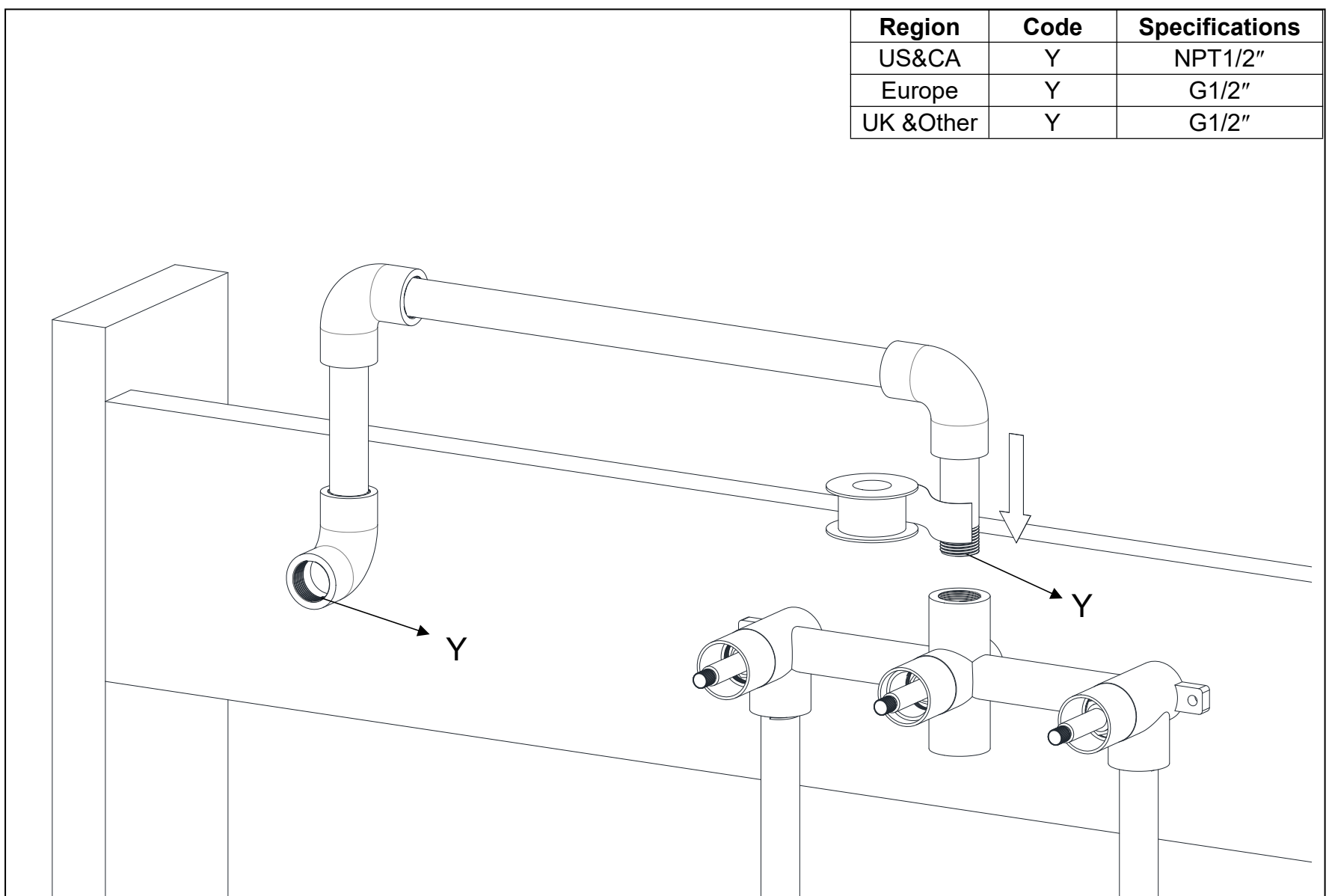

5.7 Install the feed pipe for the hand shower elbow, ensuring it is securely connected. The rough-in valve connection threads at the mixer water outlet are NPT 1/2" [US, CA].

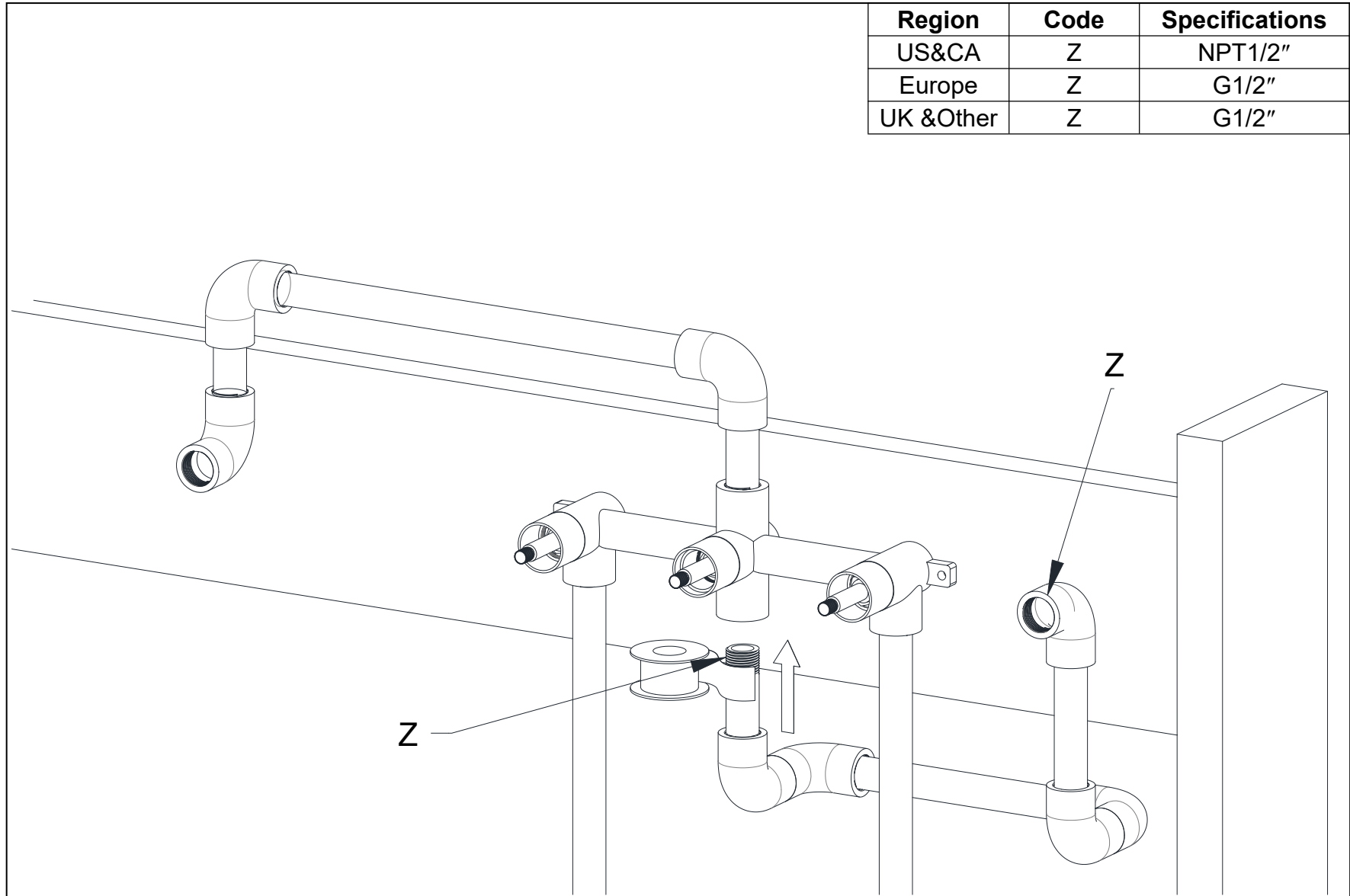

5.8 Plumbing Pressure Testing and Leak Testing.

(a.) Water Pressure Testing Standards

Test Pressure:

- The test pressure shall be 1.5 times the working pressure of the piping system, but not less than 60 PSI (pounds per square inch).
- If the design working pressure of the piping system is less than 60 PSI, the test pressure shall be 60 PSI.
- Recommended test pressure: 100 PSI to 120 PSI (approximately 6.9 to 8.2 bar).

Test Duration:

- The test duration is typically 15 minutes.
- During the test, the pressure should remain stable with no significant drop.

Testing Method:

1. Seal the piping system, ensuring all openings (e.g., faucets, valves) are closed.
2. Use a manual pump or pressure testing equipment to pressurize the system to the specified test pressure.
3. Observe the pressure gauge to ensure the pressure remains stable during the test.
4. Inspect all connections, joints, and faucets for any signs of leakage.

Pass Criteria:

- If the pressure remains stable with no significant drop and no leakage is observed during the test, the piping system passes the test.
- If the pressure drops or leakage is detected, repair the issue and retest.



Precautions:

- Safety: The test pressure should not exceed the rated pressure of the pipes and fittings to avoid damage.
- Record: Record the test pressure, duration, and results for future inspection or maintenance purposes.

(b.) Leak Testing: After completing the plumbing pressure test, turn on the hot and cold water supply again and check all connections for leaks. If no leaks are detected, shut off the hot and cold water supply and reinstall the plaster guard covers.

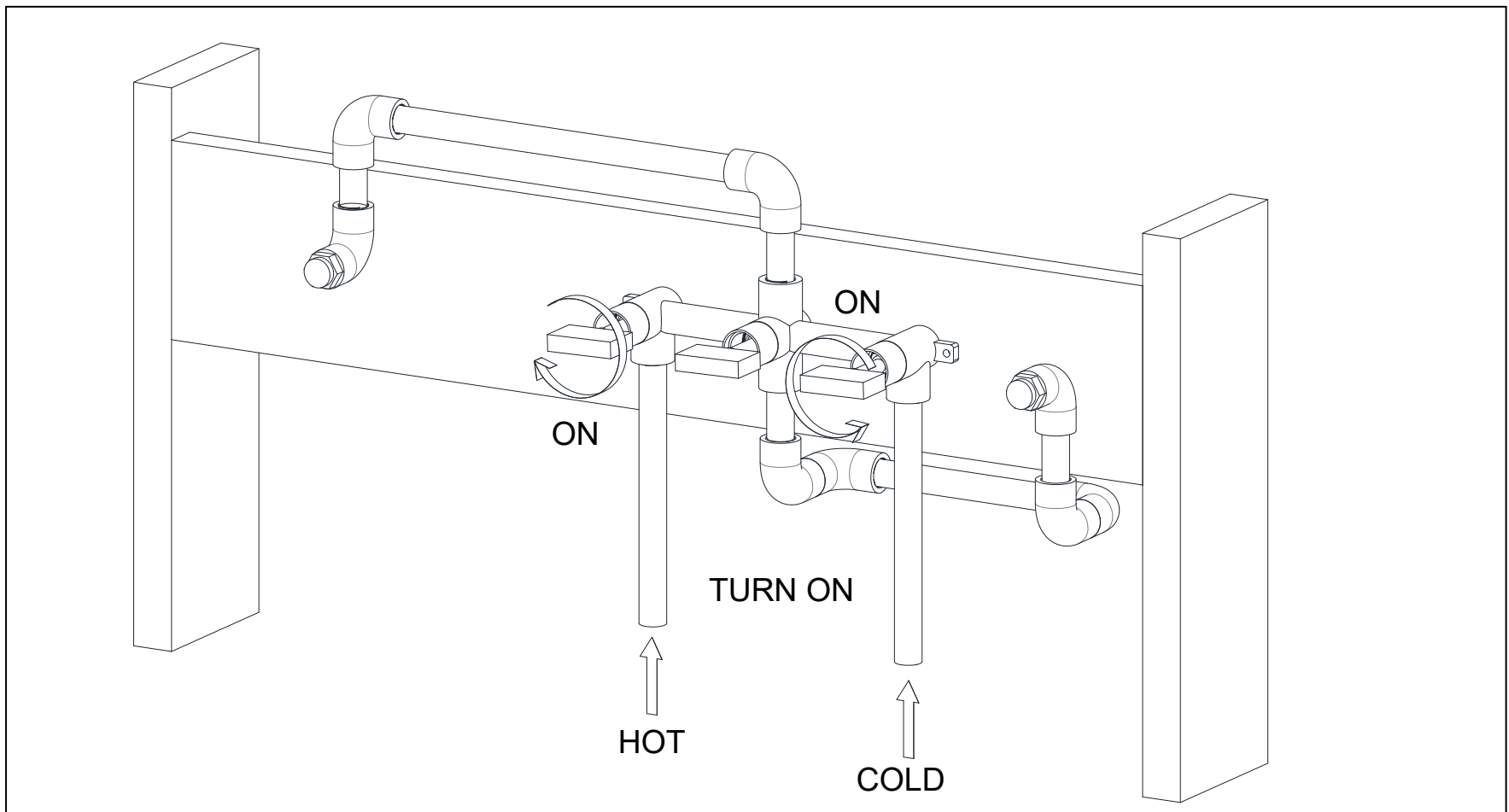

5.9 Key Alignment Requirements.

(1) Bathtub Spout Elbow Fitting: The finished surface of the bathtub spout elbow must be positioned 1/4 inch away from the finished wall to ensure correct installation.

(2) Shower Bracket Elbow Fitting: The finished surface of the shower bracket elbow must be positioned 1/4 inch away from the finished wall to ensure correct installation.

Code	Dimensions - Inch	Dimensions - mm
D	1/4"	6.4

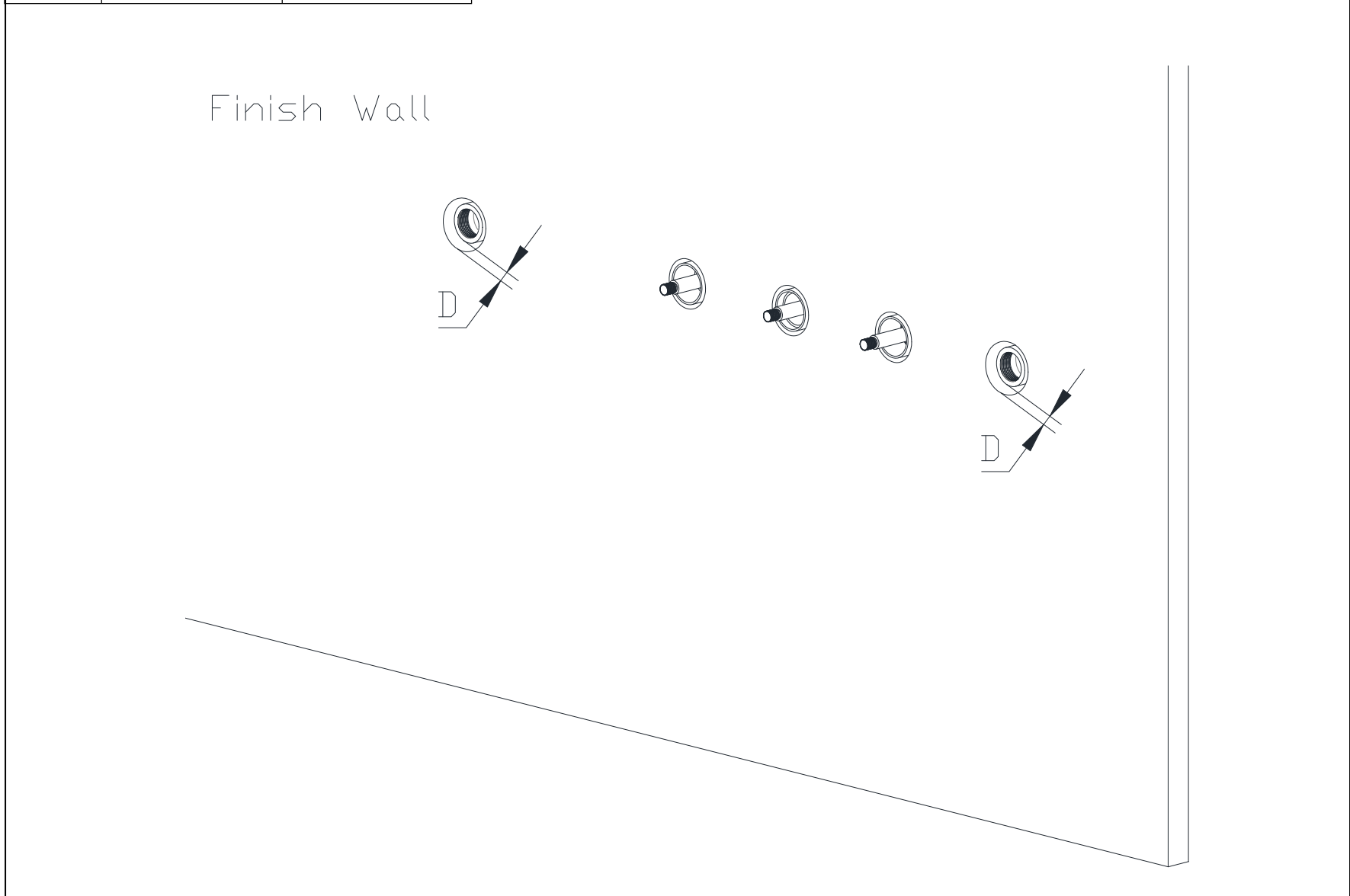

5.10 Apply Teflon tape to the threads on the spout shank, then securely connect it to the tub spout mixer outlet to ensure a proper seal.

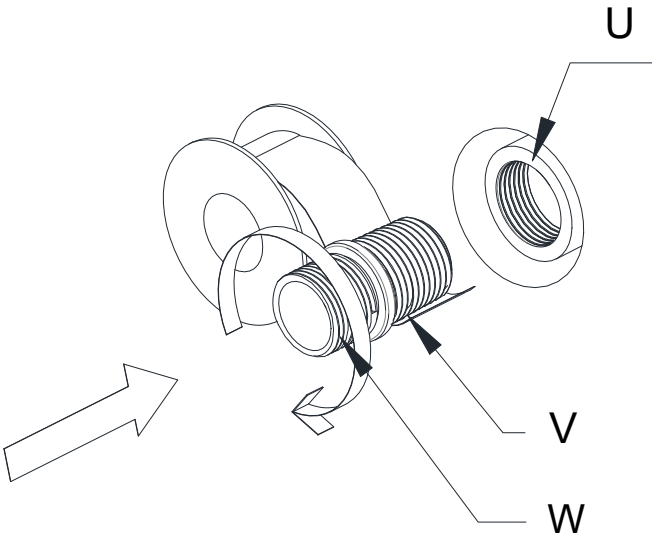

Region	Code	Specifications
US&CA	U	NPT1/2"
Europe	U	G1/2"
UK &Other	U	G1/2"
US&CA	V	NPT1/2"
Europe	V	G1/2"
UK &Other	V	G1/2"
US&CA	W	G1/2"
Europe	W	G1/2"
UK &Other	W	G1/2"

5.11 Secure the spout nipple to the supply shank using an Allen wrench.

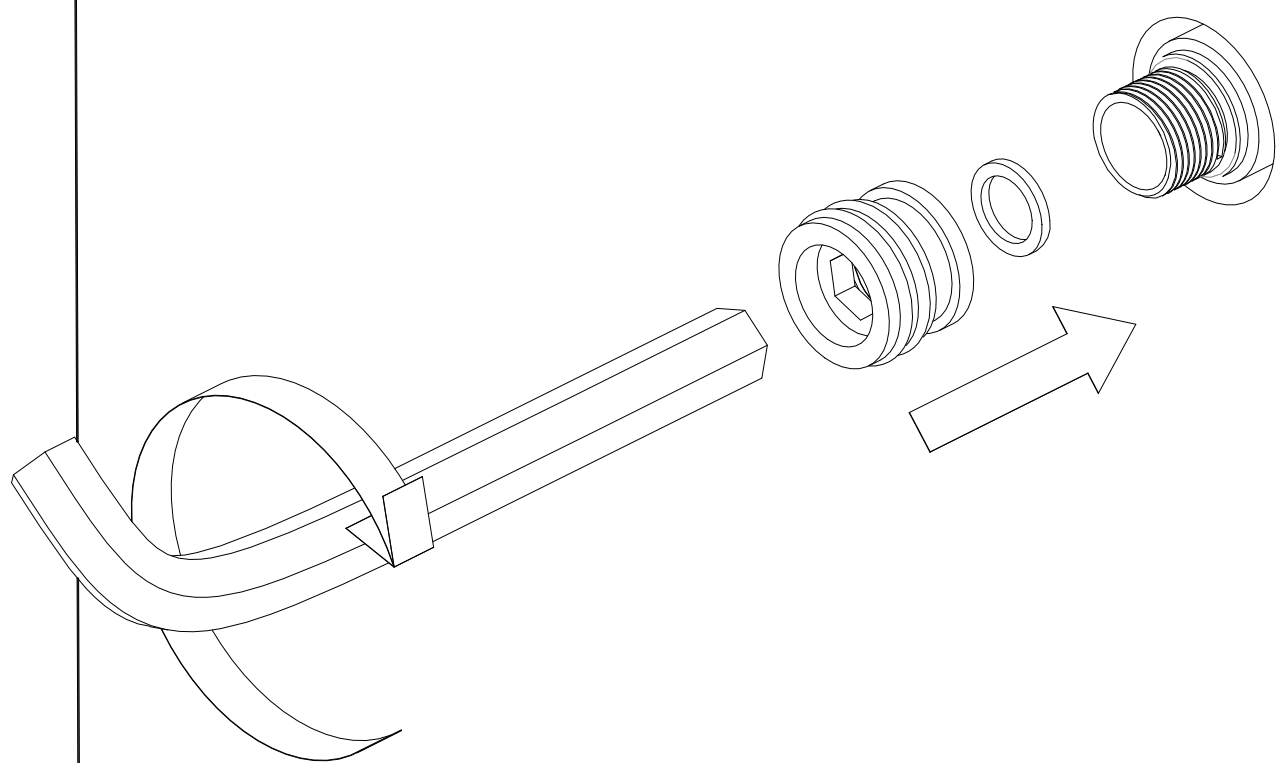

S12

5.12 Secure the spout to the nipple using the set screw and an Allen wrench.

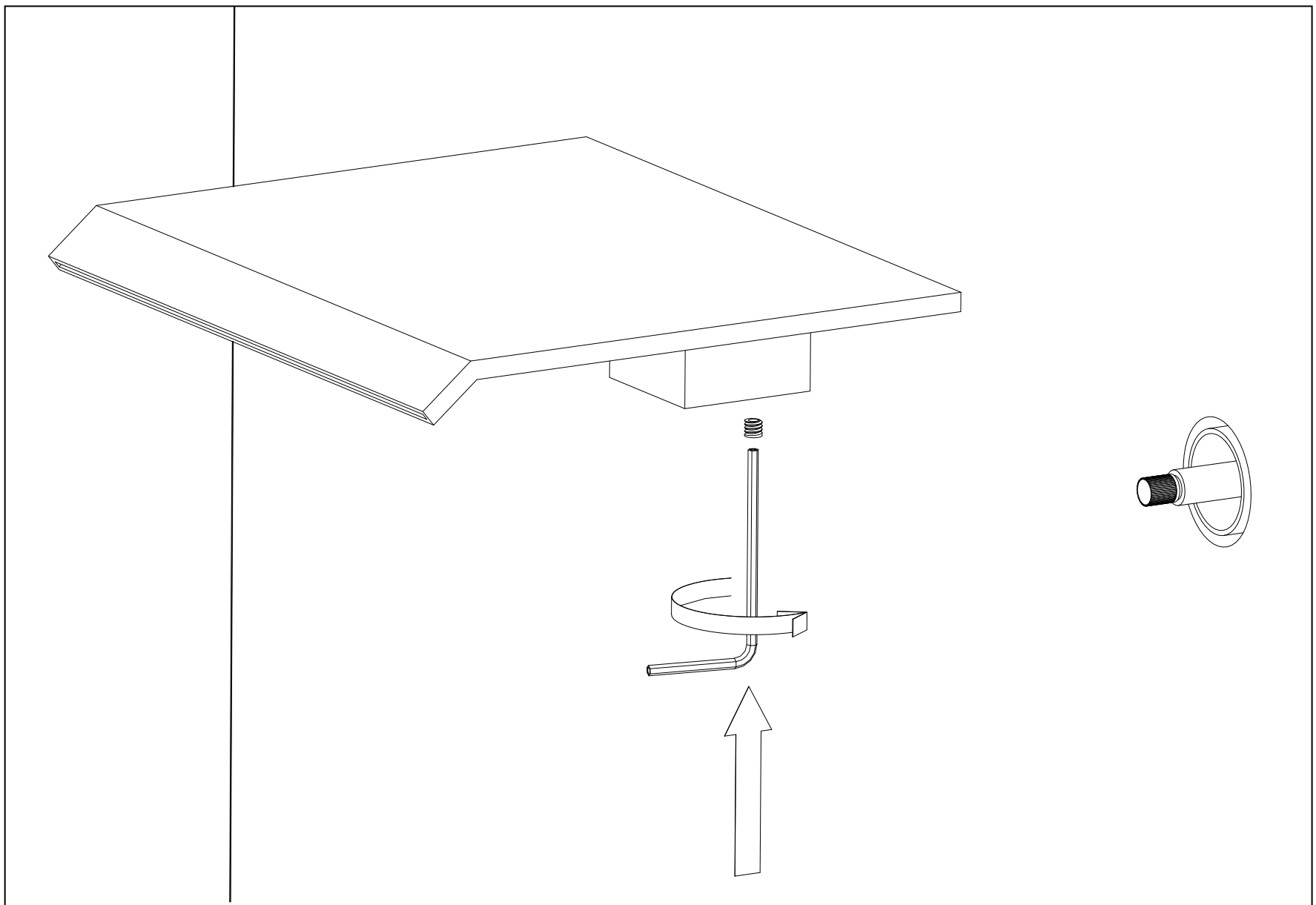
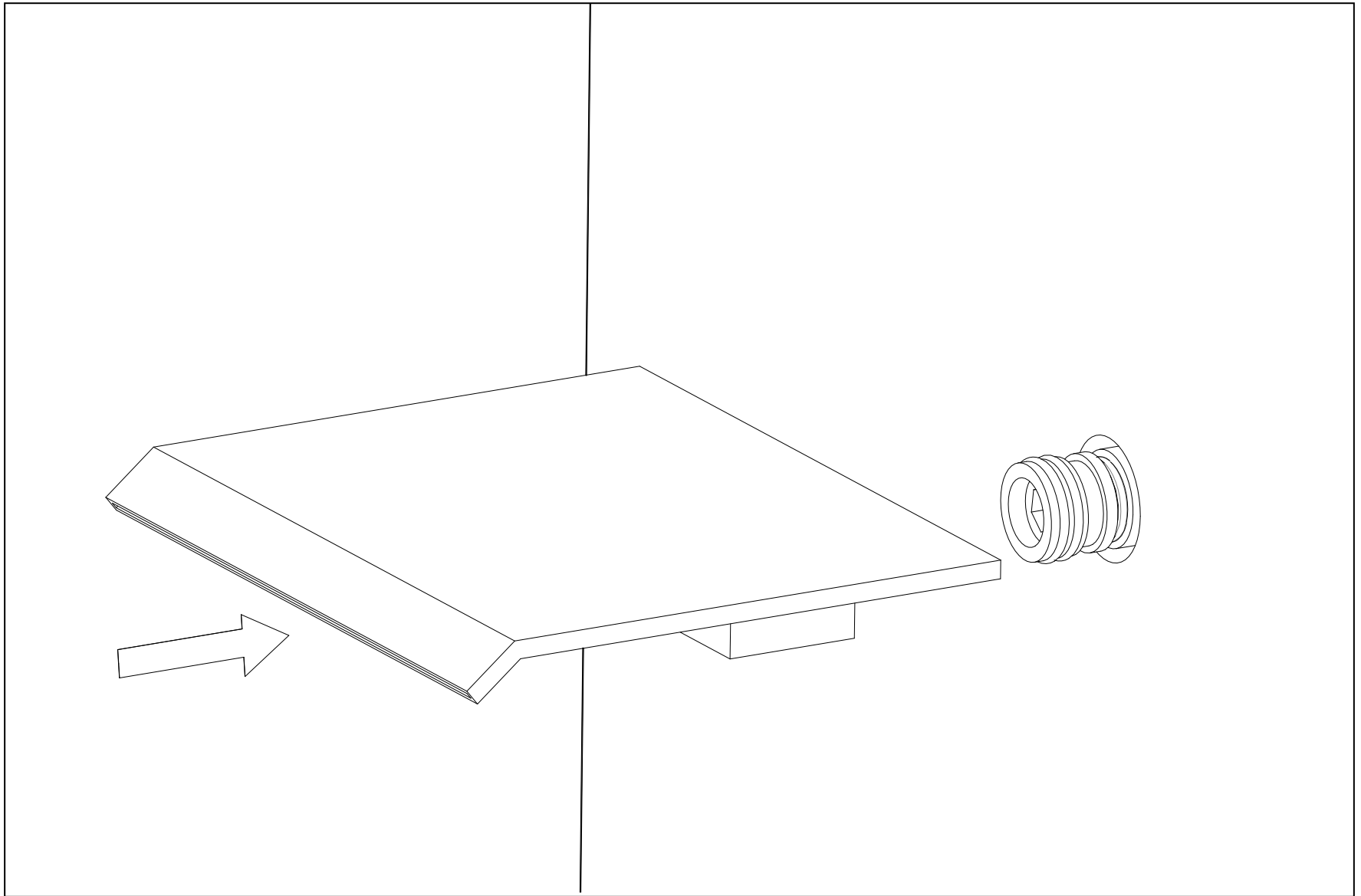

5.13 Secure the escutcheons to the cartridges, ensuring they are not overtightened, and then seal the wall around the escutcheon edges with waterproof sealant to prevent water leakage.



WARNING: Failure to properly seal the wall may result in water damage.

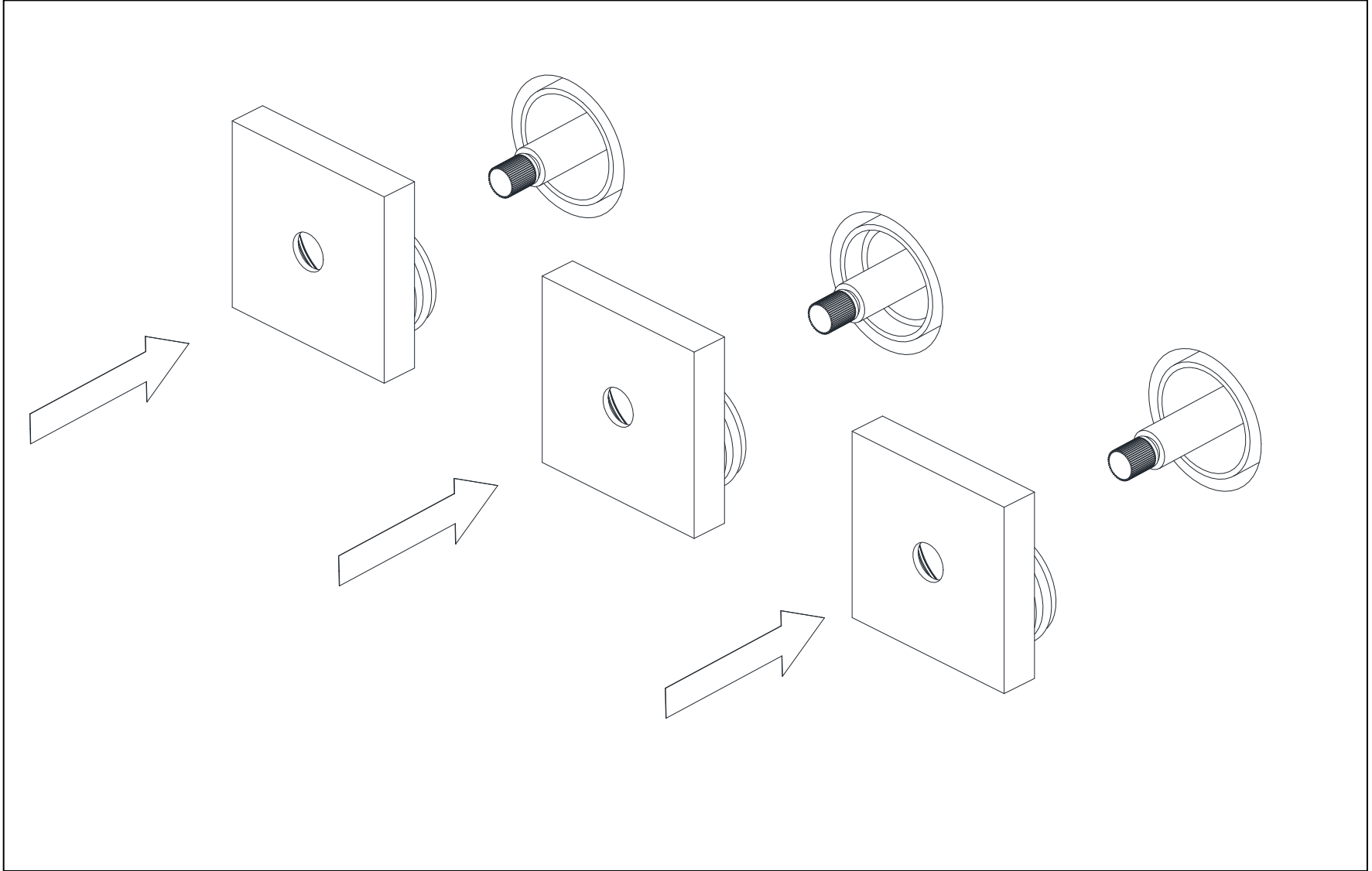

5.14 Secure the knobs to the cartridge stems using the provided screws and an Allen wrench.

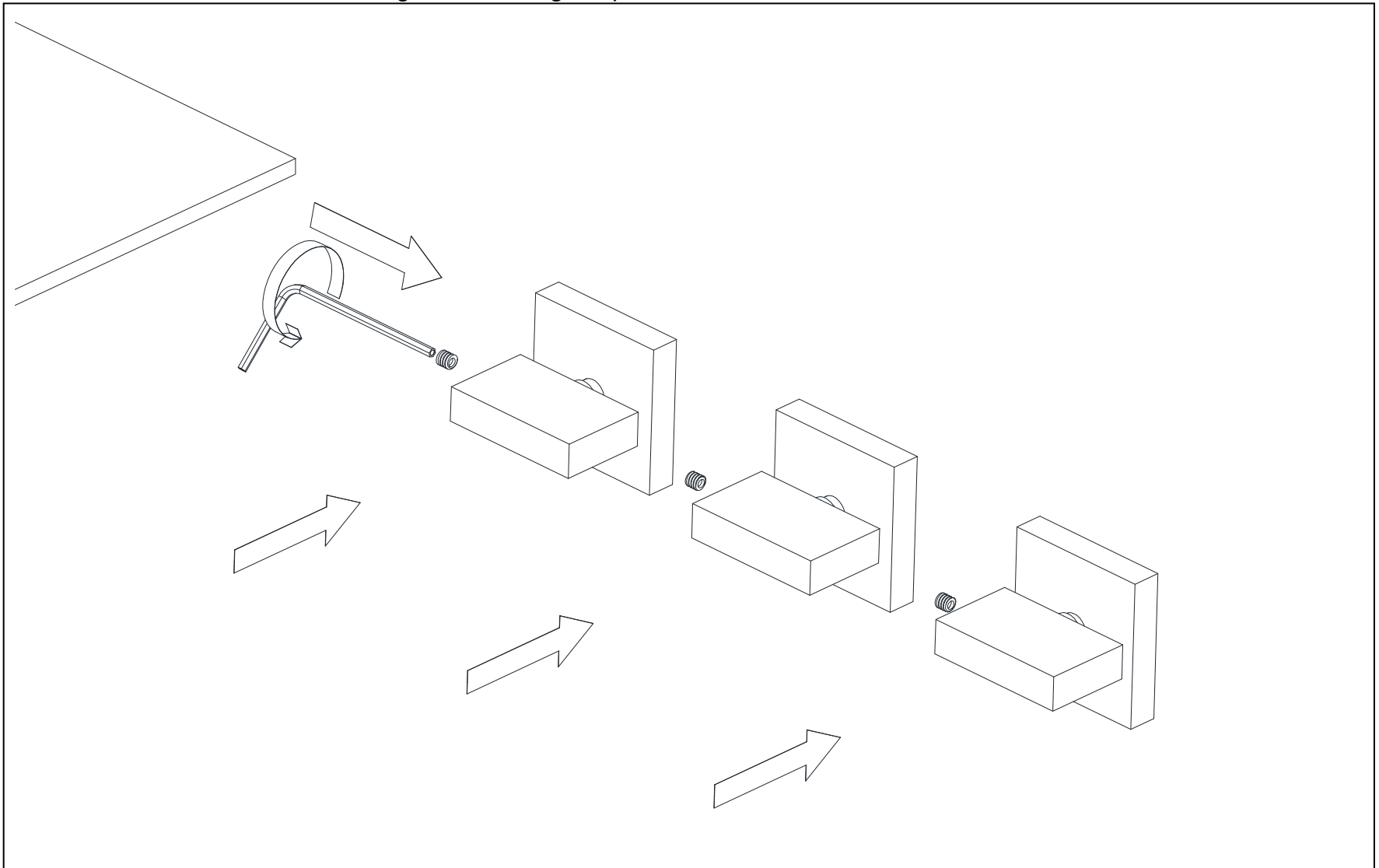

5.15 Press and secure the provided screw covers onto the screw holes on the knobs.

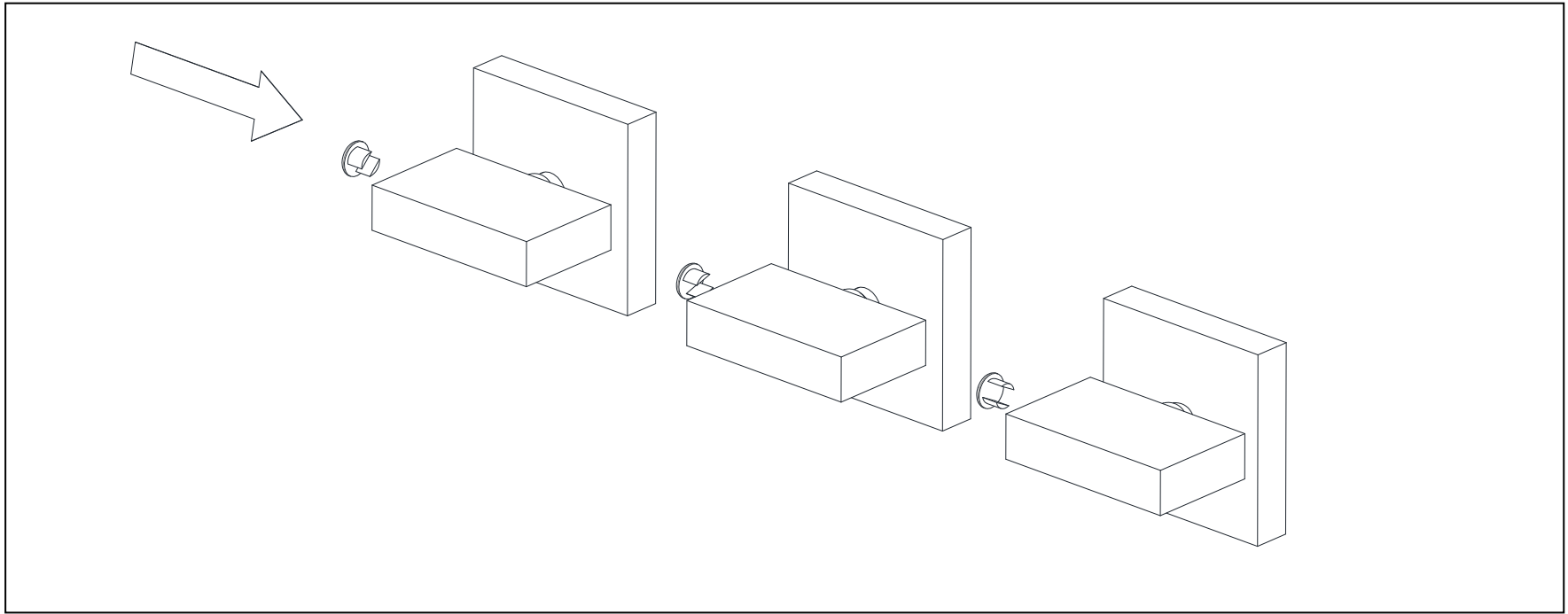

5.16 Apply Teflon tape to the threads of the nipple, then securely thread it into the pipe elbow inside the wall.

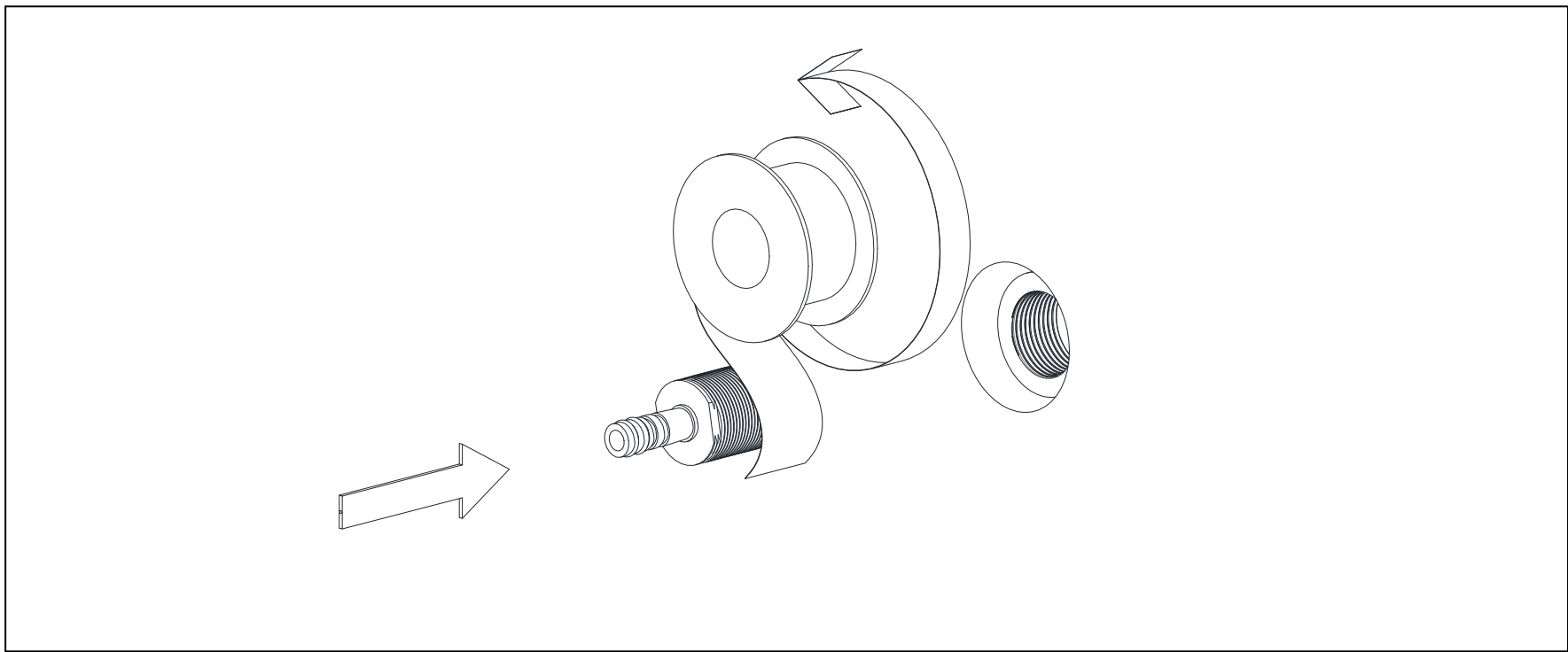

5.17 Attach the shower holder assembly to the nipple securely.

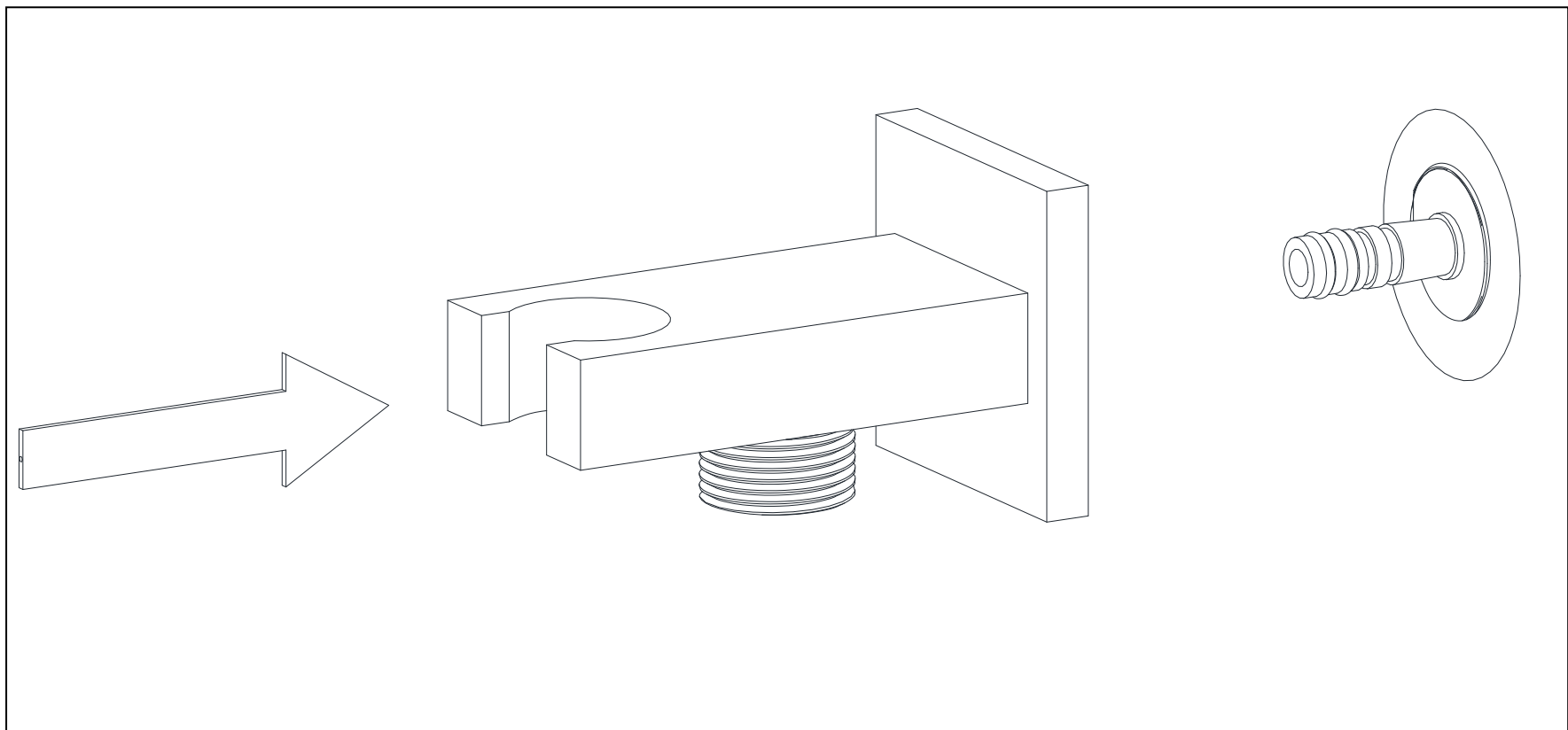

5.18 Secure the hand shower holder to the nipple using the provided set screws and an Allen wrench.

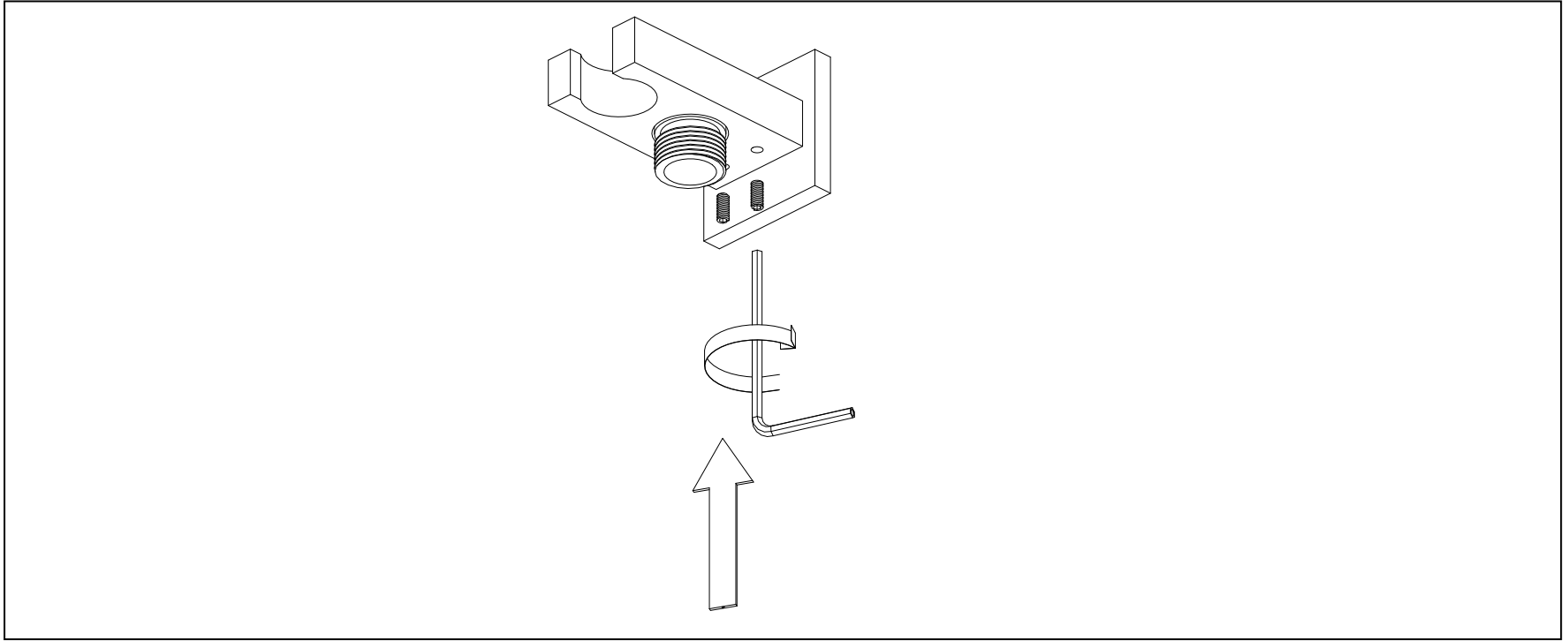

5.19. Connect the hand shower to the elbow using the flexible hose, ensuring the gasket is in place and connections are hand-tightened.

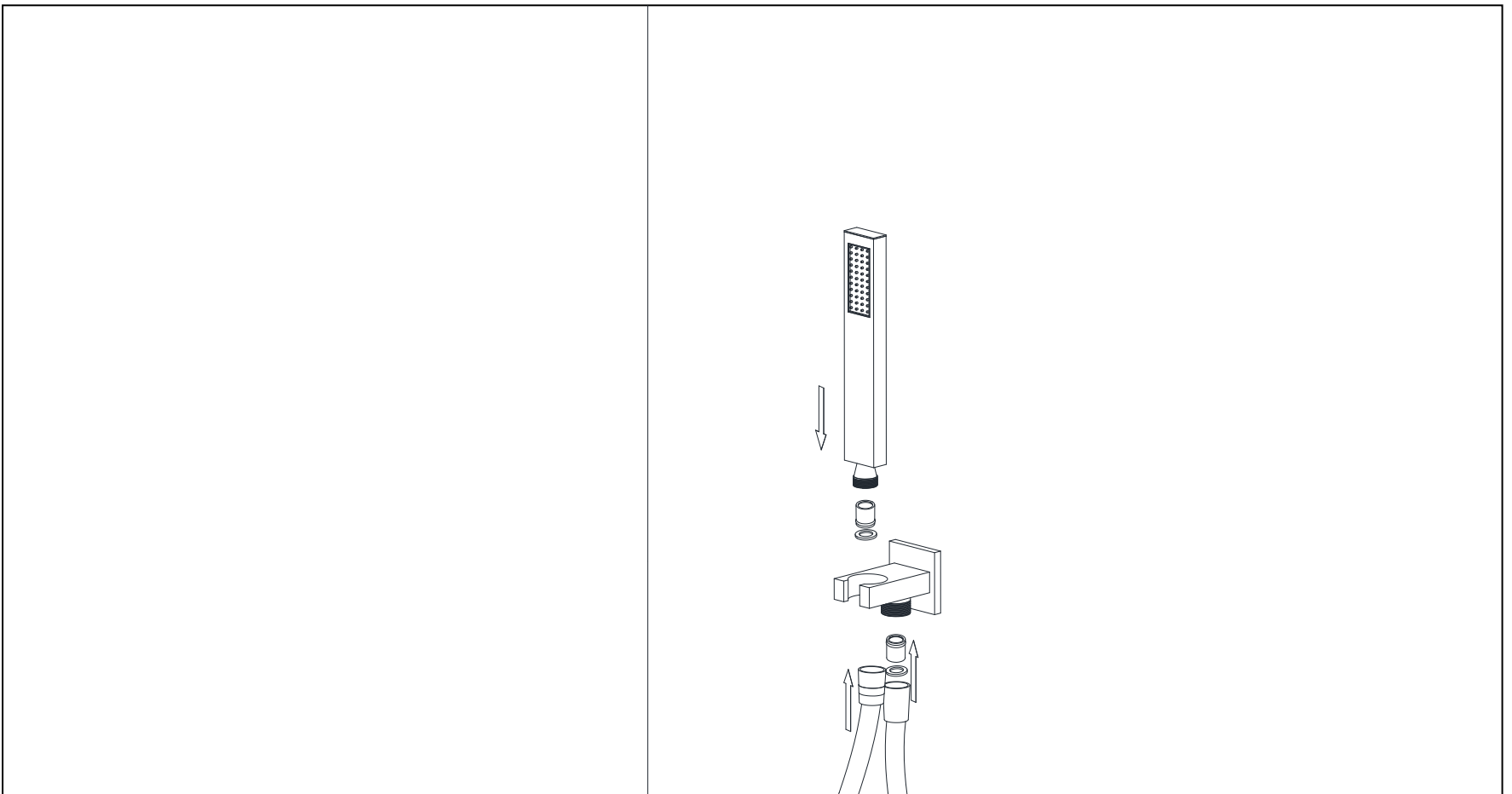

ASSEMBLY COMPLETE

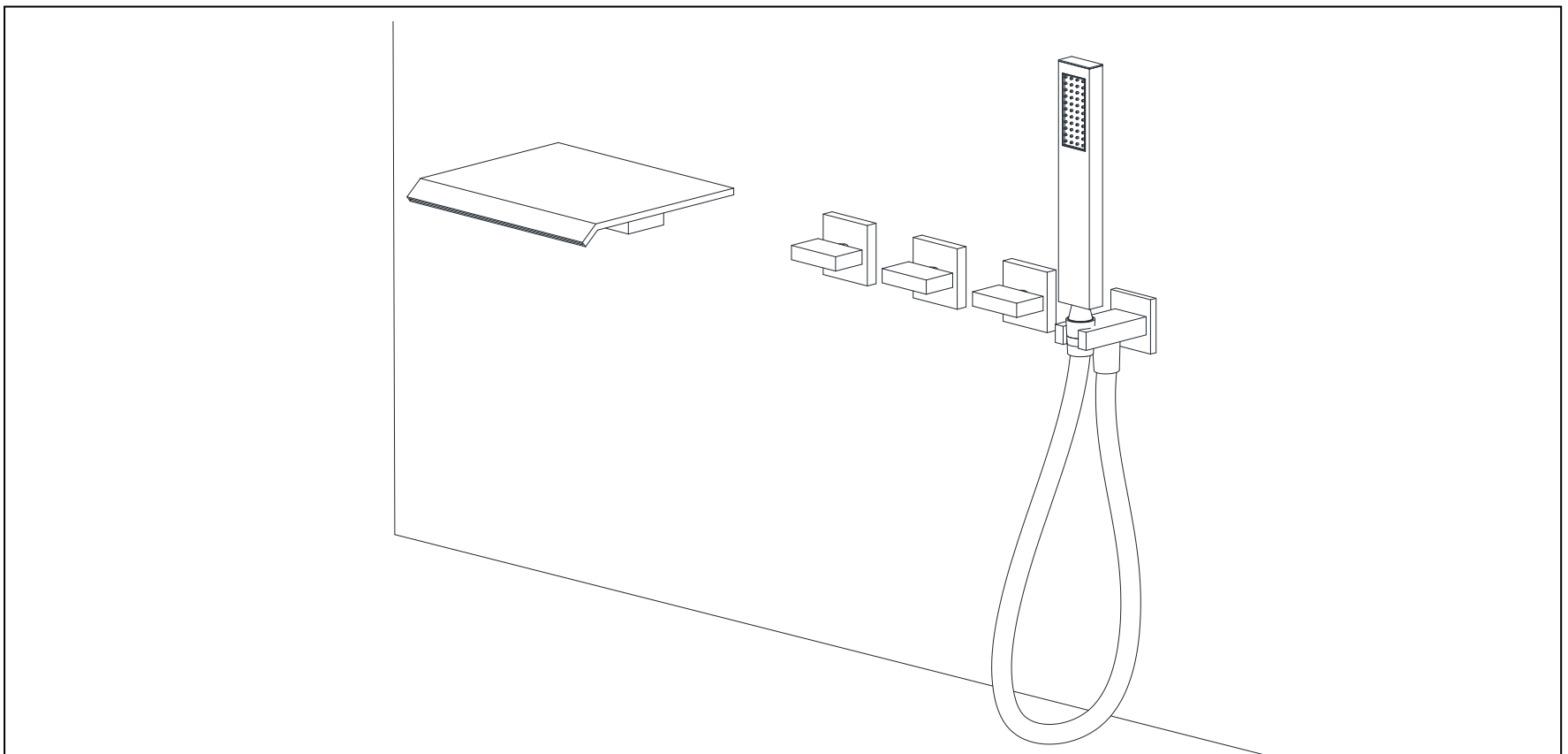

6. INSPECTION

6.1 Turn on the hot and cold water supplies and check all connections to ensure there are no leaks.

7. FUNCTION INSPECTION

7.1 Turn on the knob to allow water to flow from the spout, and turn it off to stop the water flow.

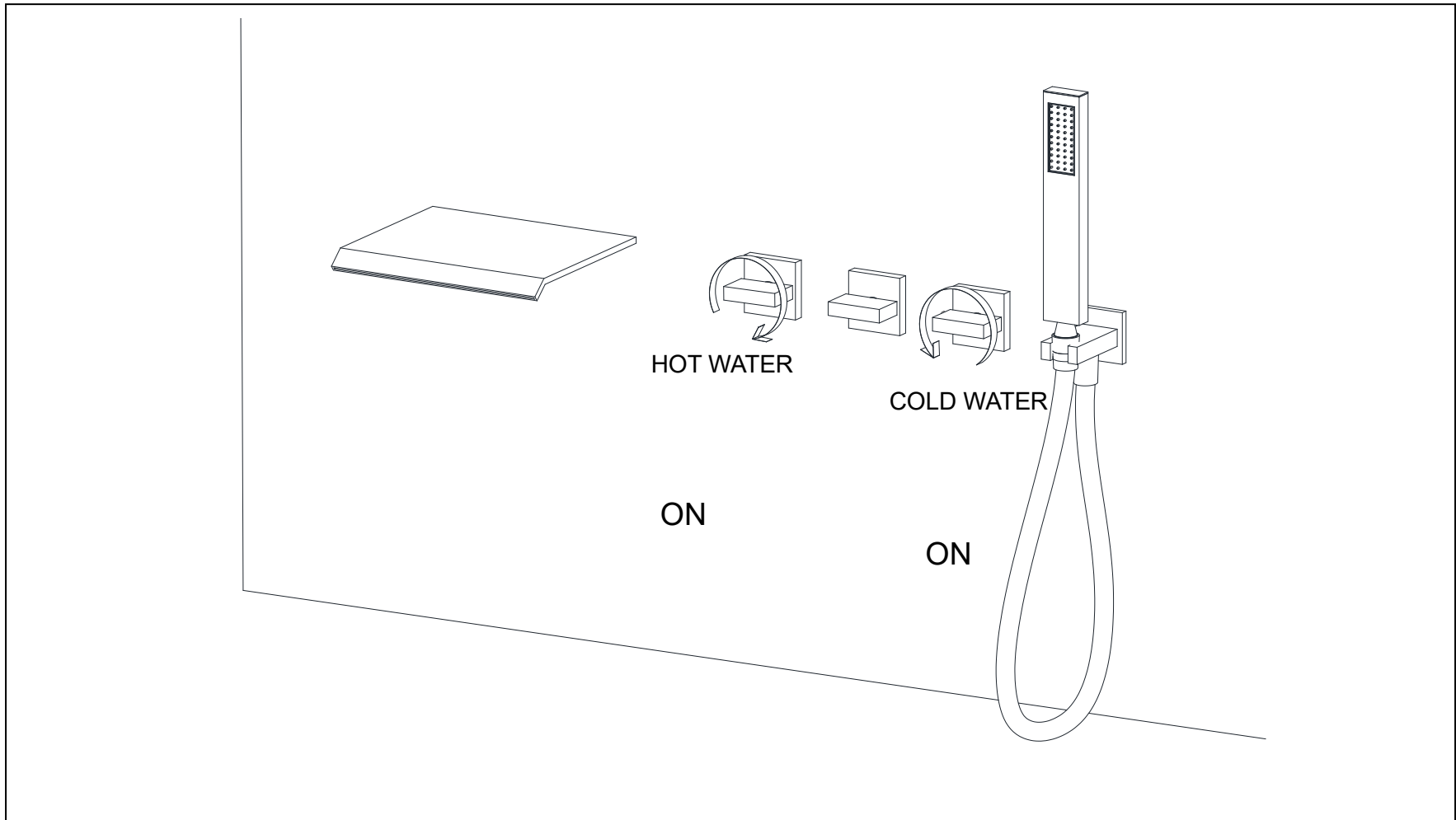

7.2 Turn the diverter knob to direct water flow to the hand shower.

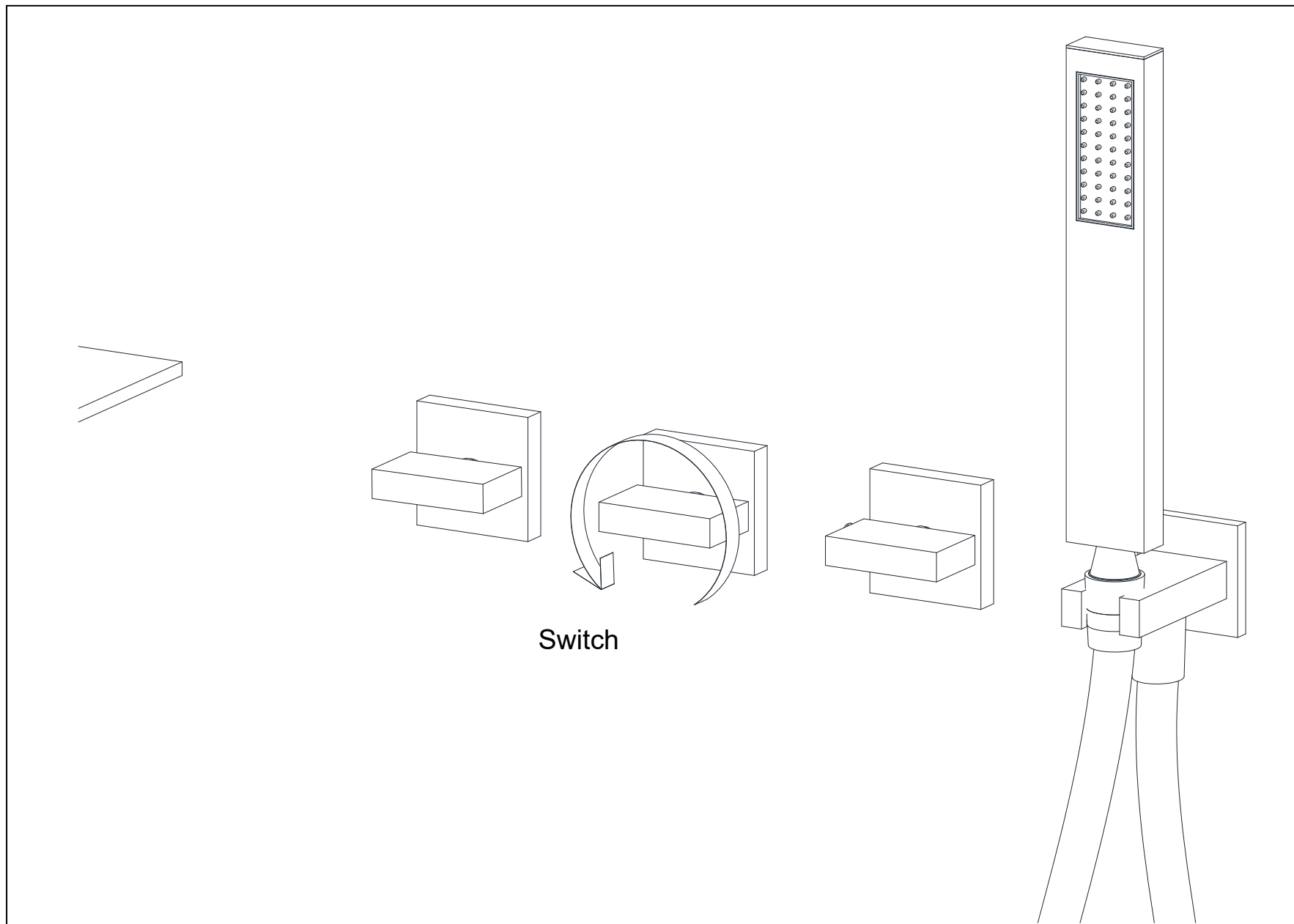

INSTALLATION COMPLETE



North America	Asia	Europe
SUMERAIN INTERNATIONAL GROUP INC	HONGKONG SUMERAIN SANITARY INDUSTRY CO., LIMITED	SUMERAIN EUROPE SUPPORT TEAM
Add: 1226 NORTH KING ST NUM 522 WILMINGTON, DE 19801 United States	Add: FLAT/RM 3B 3/F BANK TOWER NOS.351&353 KING'S ROAD NORTH POINT,HONGKONG	Add: Flottwellstr.15 10785 Berlin, Deutschland
Tel: +1(866)203-0866	Tel: +86-750-2731579	Tel: +49 (0)30/23975898
E-mail: supports@sumerain.us	E-mail: supports@sumerain.com	E-mail: de@sumerain.com