

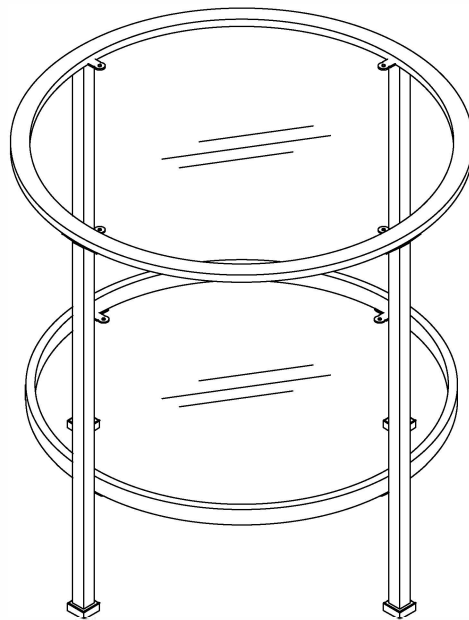

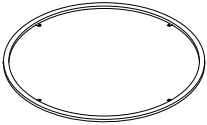

Glass Side Table

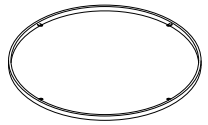
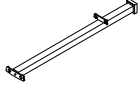

PART LIST

<div data-bbox="108 219 151 264" style="border: 1px solid black; padding: 2px;">A</div> 	<div data-bbox="383 219 426 264" style="border: 1px solid black; padding: 2px;">B</div> 	<div data-bbox="659 219 702 264" style="border: 1px solid black; padding: 2px;">C</div> 	<div data-bbox="935 219 978 264" style="border: 1px solid black; padding: 2px;">D</div> 	<div data-bbox="1211 219 1254 264" style="border: 1px solid black; padding: 2px;">E</div> 
<p style="text-align: center;">Top Frame 1 PC</p>	<p style="text-align: center;">Bottom Frame 1 PC</p>	<p style="text-align: center;">Leg 4 PCS</p>	<p style="text-align: center;">Top Glass 1 PC</p>	<p style="text-align: center;">Bottom Glass 1 PC</p>

HARDWARE LIST

<div data-bbox="108 801 151 846" style="border: 1px solid black; padding: 2px;">#1</div> 	<div data-bbox="383 801 426 846" style="border: 1px solid black; padding: 2px;">#2</div> 
<p style="text-align: center;">M6 x 1/2"L</p> <p style="text-align: center;">Bolt 16 PCS (Extra 2)</p>	<p style="text-align: center;">Allen Wrench 1 PC</p>

Step 1. Carefully lay top frame (part A) upside down on a soft surface, such as carpet, as shown below. Attach legs (part C) to top frame (part A) using bolts (part #1) and allen wrench (part #2).

NOTE: Please do not fully tighten bolts until unit is fully assembled.

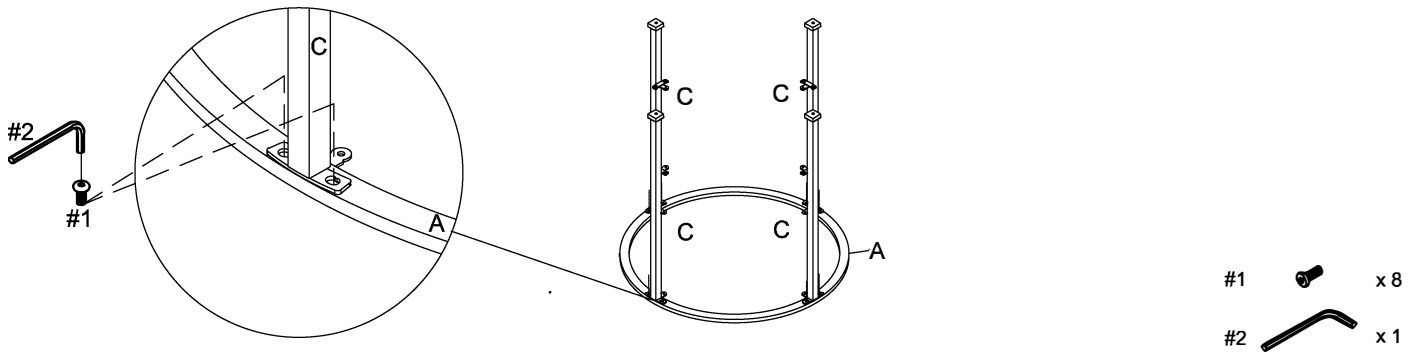

Step 2. Attach bottom frame (part B) to legs (part C) using bolts (part #1) and allen wrench (part #2).

NOTE: Please fully tighten all bolts at this time.

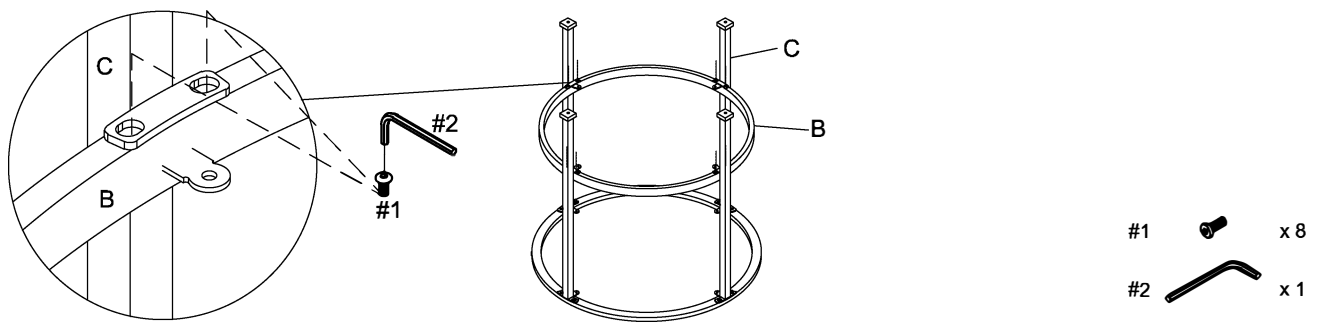

Step 3. Carefully turn unit upright. Install bottom glass (part E) into bottom frame (part B) and top glass (part D) into top frame (part A).

