

ASSEMBLY INSTRUCTIONS  
8-DOOR CORNER CABINET

User ' s Manual

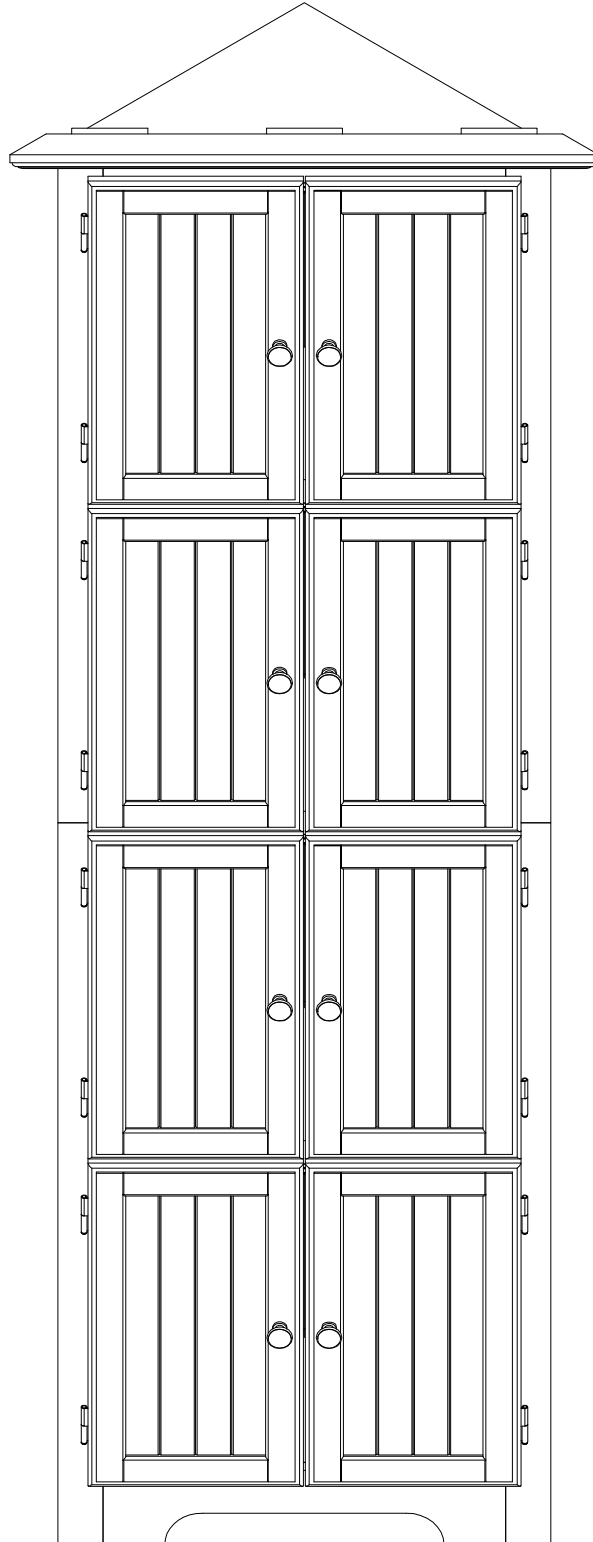



# ASSEMBLY INSTRUCTIONS

## 8-DOOR CORNER CABINET

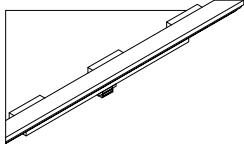
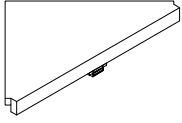
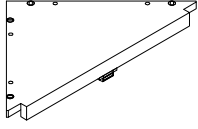
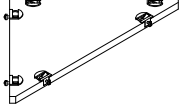
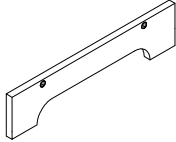
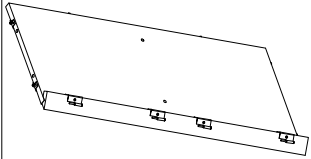
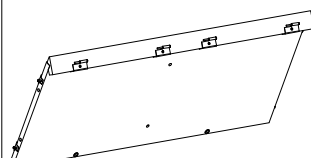
### Part List:

ITEM	DESCRIPTION	PART	QTY
1	Top		1
2	Shelf		2
3	Middle panel		1
4	Bottom		1
5	Apron		1
6	Upper left side		1
7	Upper right side		1

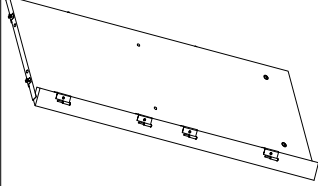
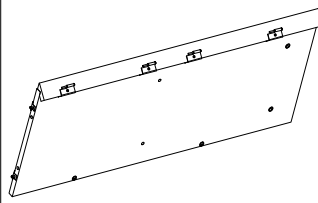
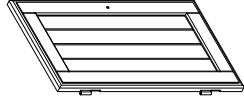
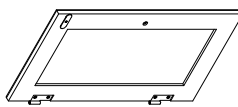
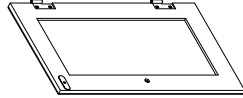

### Part List:

ITEM	DESCRIPTION	PART	QTY
8	Lower left side		1
9	Lower right side		1
10	Upper left door		1
11	Upper right door		1
12	Lower left door		3
13	Lower right door		3

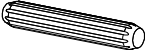

# ASSEMBLY INSTRUCTIONS

## 8-DOOR CORNER CABINET

### Hardware List:

ITEM	DESCRIPTION	PART	QTY
A	Short wooden dowel		12
B	Long wooden dowel		4
C	Plastic anchor		1
D	Mounting screw		1

### Hardware List:

ITEM	DESCRIPTION	PART	QTY
E	Flat washer		1
F	Glue		1
G	Knob		8

# ASSEMBLY INSTRUCTIONS

## 8-DOOR CORNER CABINET

### Wooden Dowel Installation Procedure

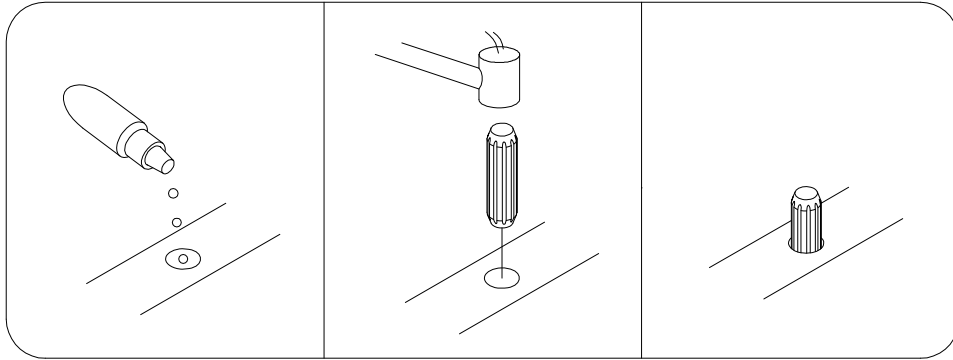

APPLY GLUE INTO PRE-DRILLED HOLE,  
AND GENTLY TAP WOOD DOWEL INTO  
THE HOLE WITH RUBBER Mallet.

\* GLUE—DO NOT PUT IN MOUTH

### Guideline For Assembling of Plastic Lock

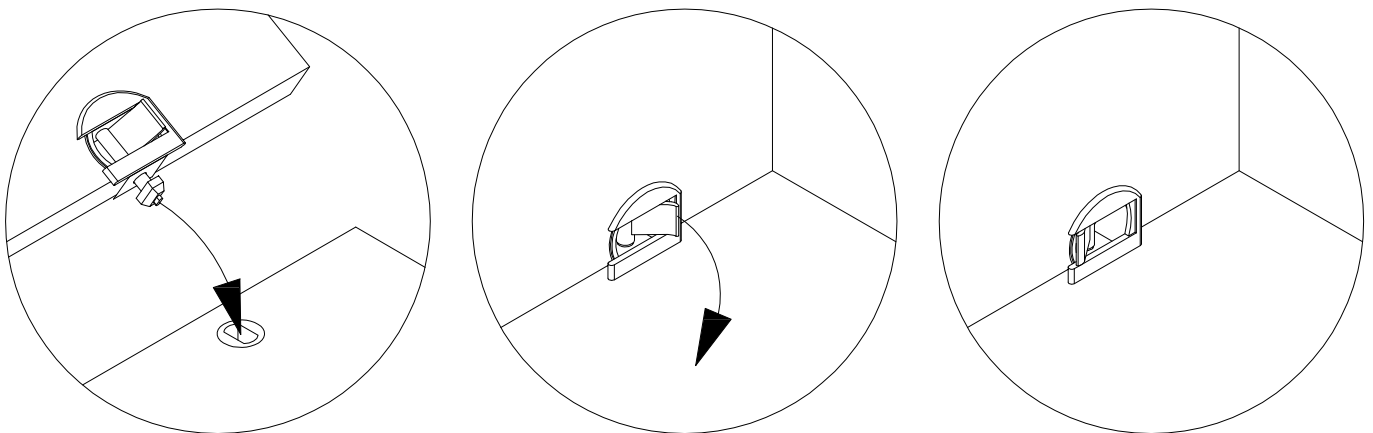

# ASSEMBLY INSTRUCTIONS

## 8-DOOR CORNER CABINET

### STEP 1

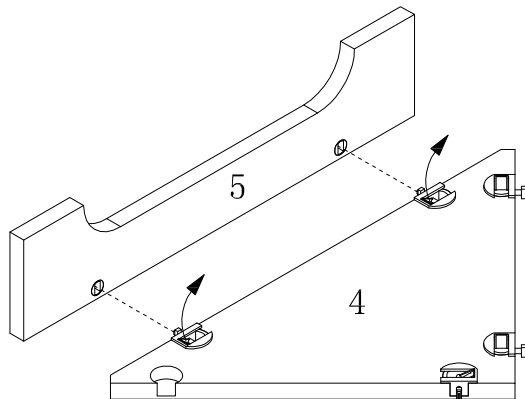

### STEP 2

A:  2PCS

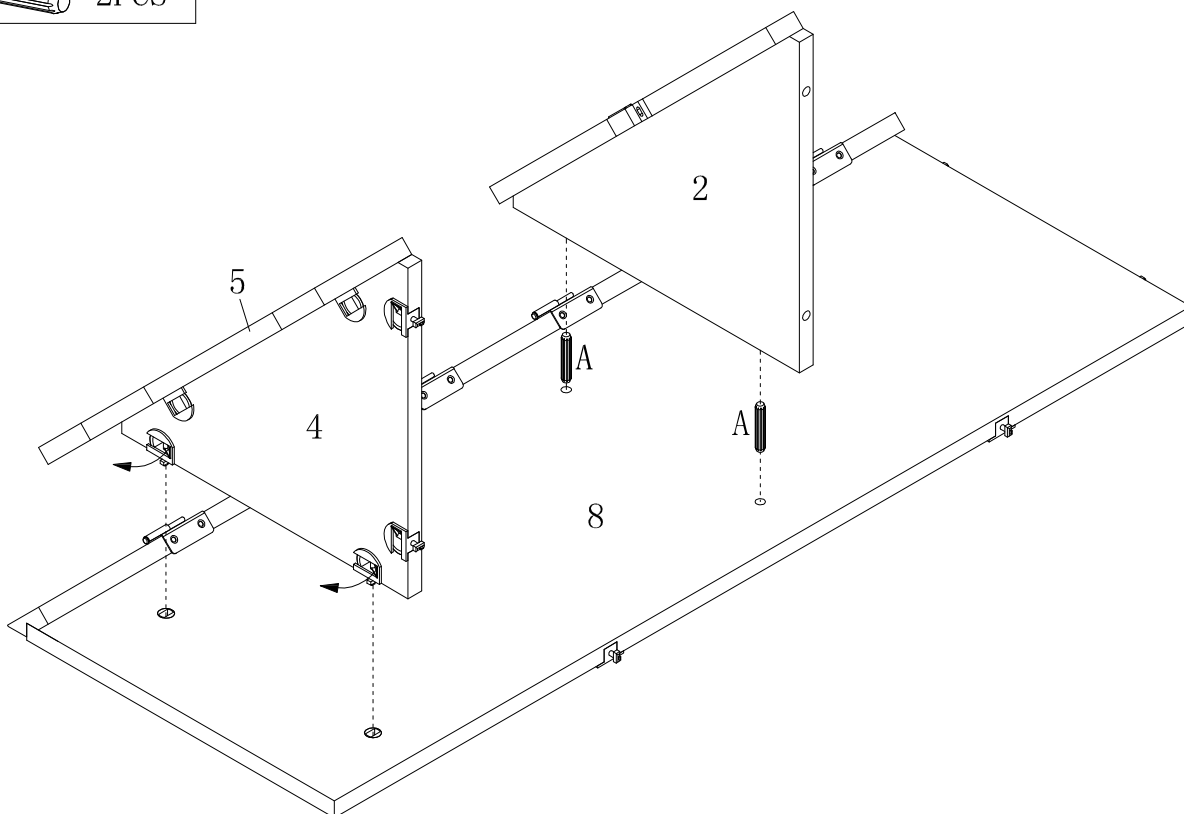

# ASSEMBLY INSTRUCTIONS

## 8-DOOR CORNER CABINET

### STEP 3

A:  2PCS

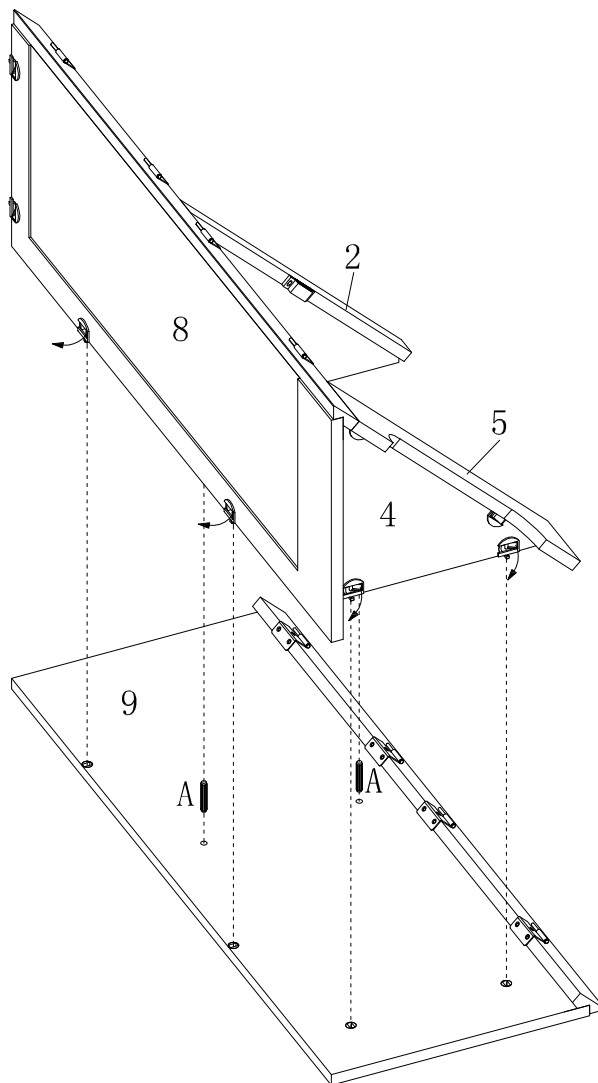

### STEP 4

A:  2PCS

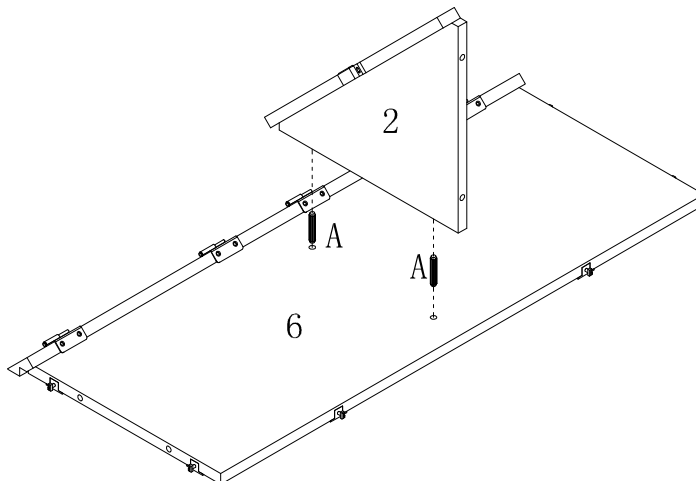

# ASSEMBLY INSTRUCTIONS

## 8-DOOR CORNER CABINET

### STEP 5

A:  2PCS

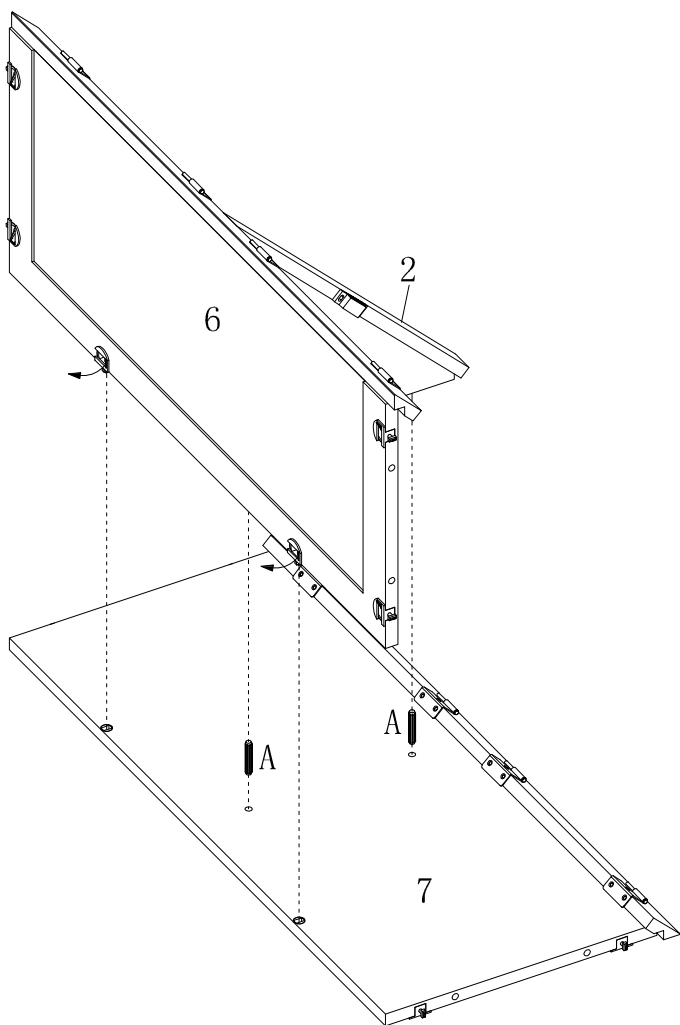

### STEP 6

B:  4PCS

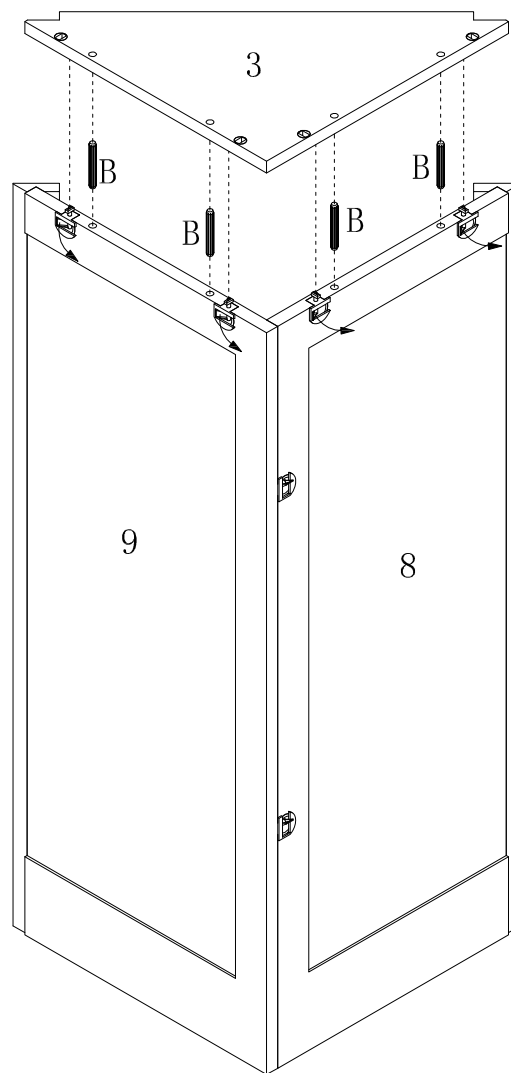

# ASSEMBLY INSTRUCTIONS

## 8-DOOR CORNER CABINET

### STEP 7

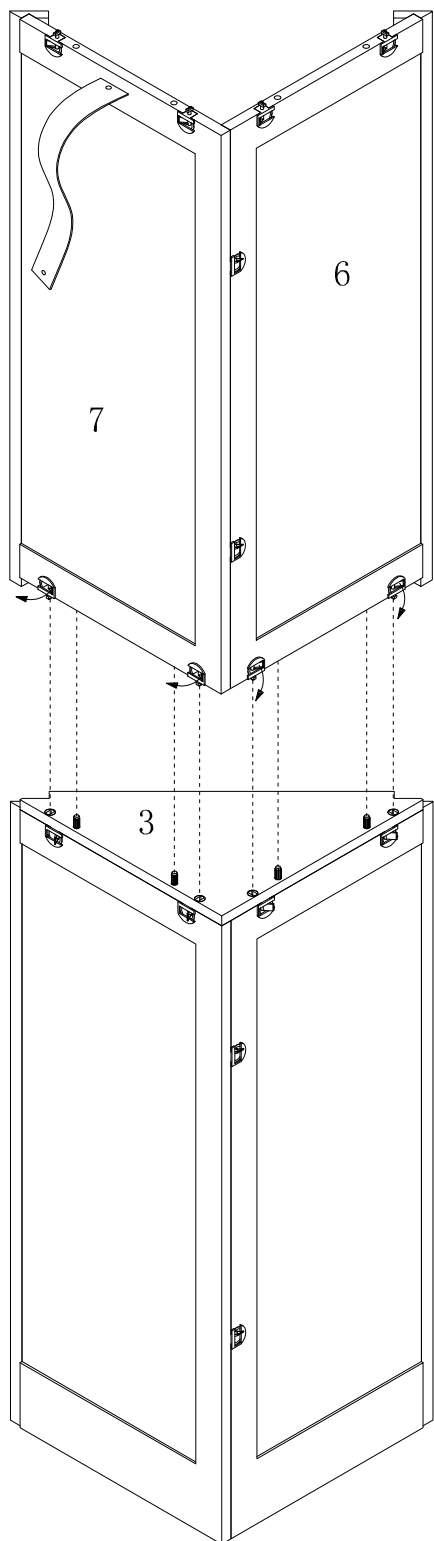

### STEP 8

A:  4PCS

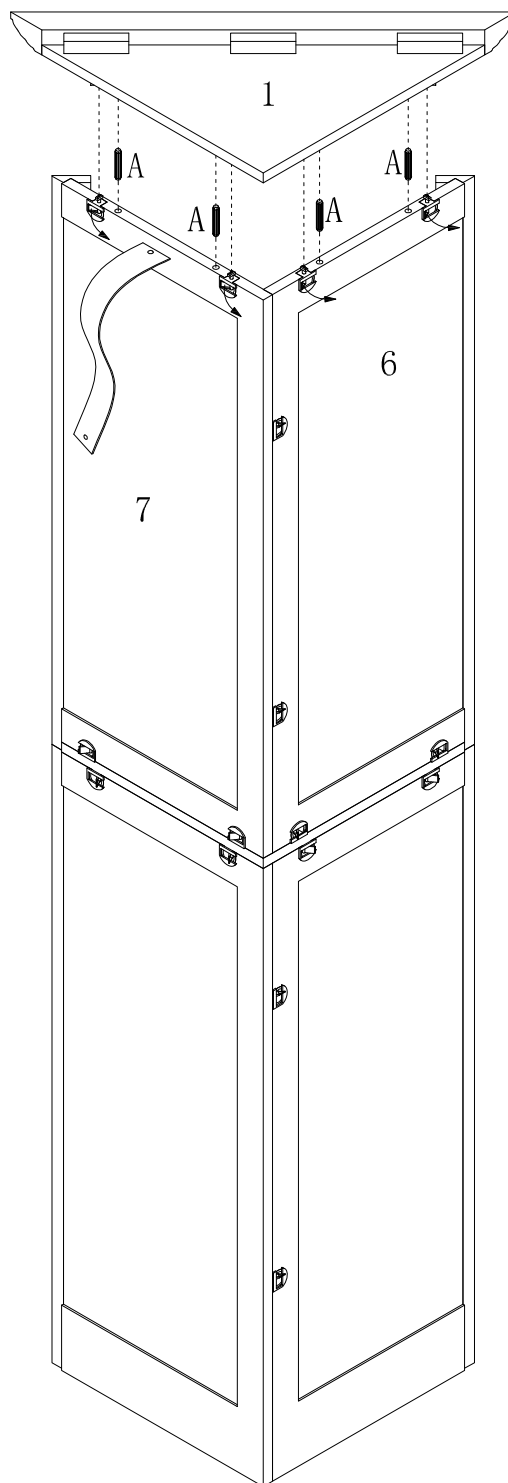

# ASSEMBLY INSTRUCTIONS

## 8-DOOR CORNER CABINET



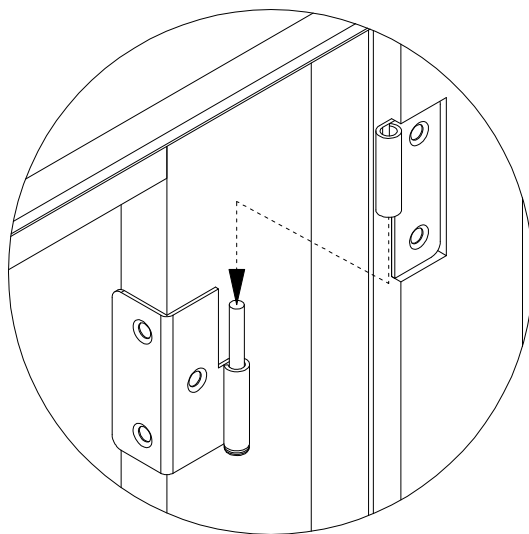
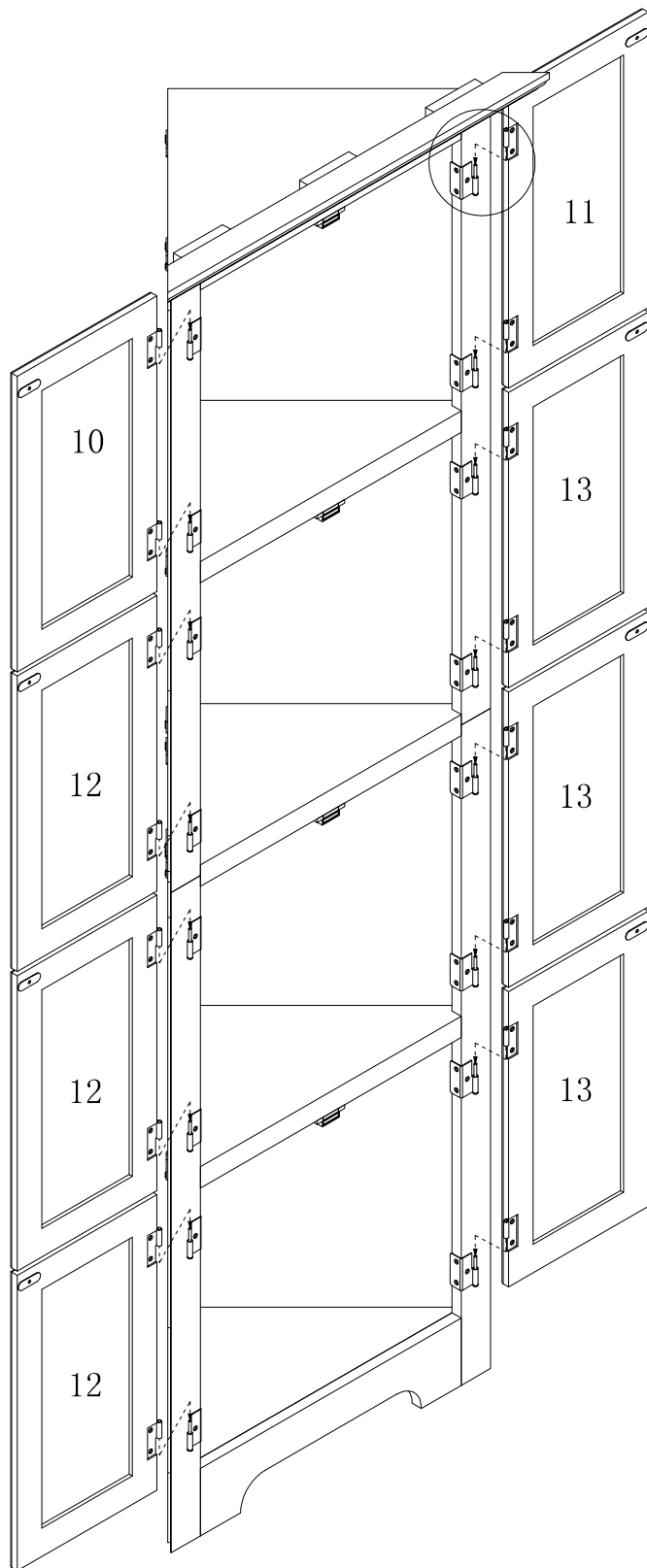

### STEP 9



# ASSEMBLY INSTRUCTIONS

## 8-DOOR CORNER CABINET

### STEP 10

C:		1PC
D:		1PC
E:		1PC
G:		8PCS

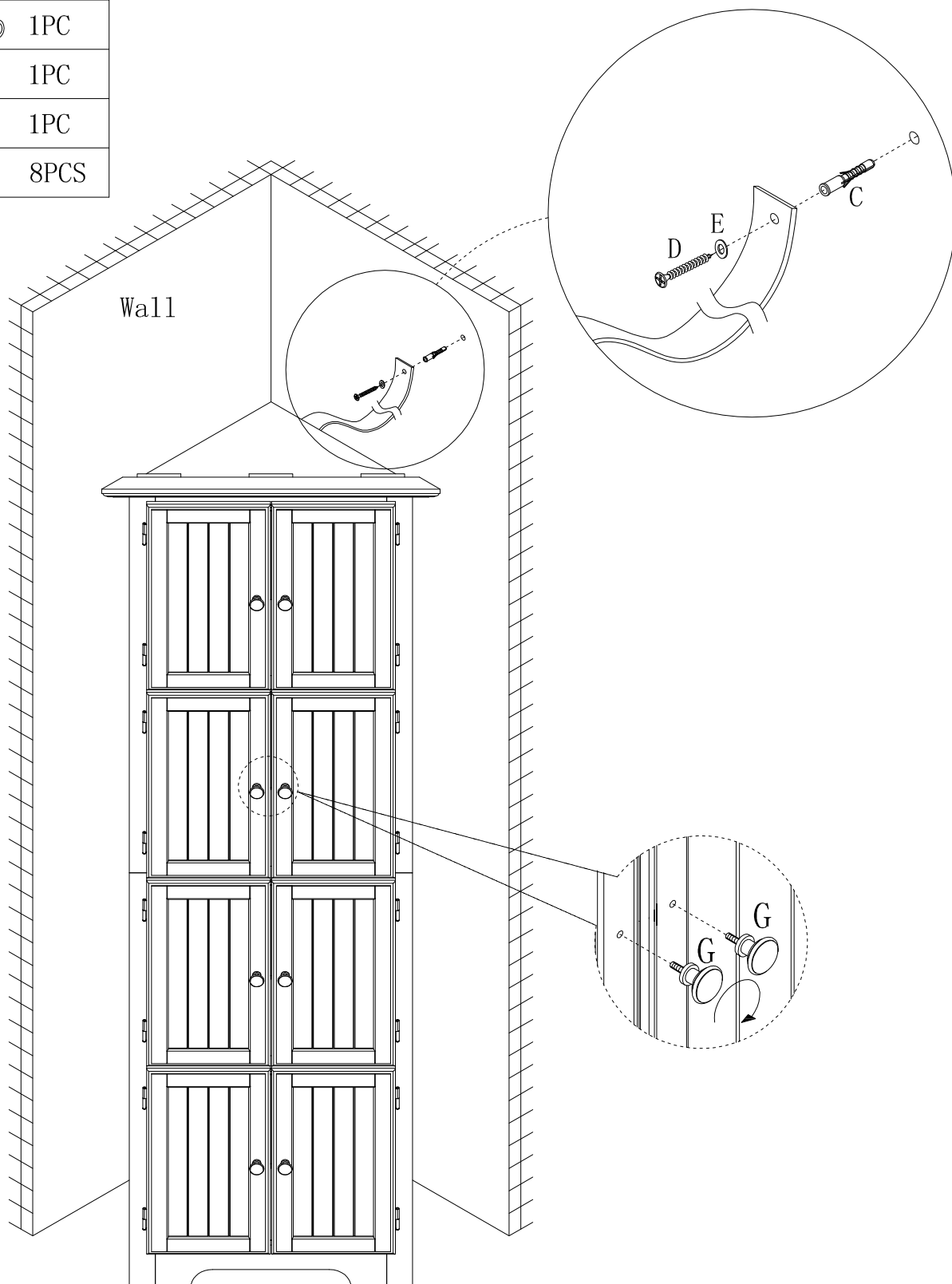

## **IMPORTANT-READ CAREFULLY-RETAIN FOR FUTURE**

### **REFERENCE**

**WARNING** Children must stay away from the assembly zone, preventing children from potential asphyxia because of plastic bag and foam breathing in nose;

**WARNING** For your safety, please do not tread or climb product.

**WARNING** The loading weight of seating shall be within the range that vendor claims.

**WARNING** The product is designed for adults use, domestic use and indoor use only.

**WARNING** The product shall not combine with other product for use.

**WARNING** If the product with seat height adjustments with energy accumulators that only trained personnel may replace or repair seat height adjustment components with energy accumulators

**WARNING** check regularly that all assembly fastenings are properly tightened, do not use the product if any structural part is broken or missing

**WARNING** Incorrect installation and incorrect use can cause accidents. Please completely follow the guidance of assembly instruction.

### **Security instructions**

Before assembling check whether all parts listed in the parts list have been delivered. Do not start assembling if parts are missing or damaged.

A failure to assemble this product correctly could cause damage or result in serious injury! Before assembling make sure that you have enough space for the procedure. Assemble on a flat surface.

Keep the assembly instructions available at all times and follow each of the individual steps exactly.

During assembly, be careful with all the parts of the assembly (do not walk on them or distort them) and beware of shearing and trapping risks. Keep children and pets away while setting up the furniture.