

ASSEMBLY INSTRUCTIONS

ROUND DINING TABLE

ASSEMBLY
REQUIREMENTS

2-Person
Assembly

Assembly Time 45 Minutes
(Approximate)

Thank you for purchasing our product!

Please refer and use this assembly instruction to assemble the product. Contact our customer service department in case there are any missing or damage parts or hardware. Replacement parts are normally shipped within 2 or 3 days.

We appreciate your business!

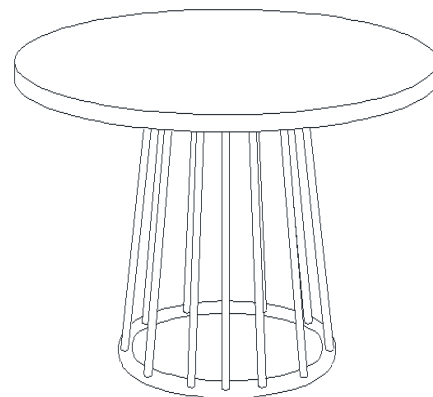

ASSEMBLY PREPARATION

1. Remove all packaging materials, staples and packing straps from the carton.
2. Refer to Parts List and Hardware List, and ensure parts and hardware are correct before assembly. Contact customer service for missing parts.
3. Place all wooden parts on a clean, flat and soft surface (e.g., carpet or rug) to prevent scratch and damage to parts.

SAFETY PRECAUTION

1. KEEP ALL HARDWARE PARTS OUT OF REACH OF CHILDREN.
2. DISPOSE PLASTIC PACKAGING MATERIAL IMMEDIATELY TO AVOID ANY RISK OF SUFFOCATION TO CHILDREN AND ANIMALS.

TIPS FOR ASSEMBLY

1. Allow ample room for assembly and assemble the product close to where the product will be placed.
2. Assemble the product on a surface that does not scratch or damage the exterior gloss and finish of the furniture.
3. Identify all of the parts, hardware and quantities required for each step.
4. During assembly, do not over-tighten any fittings as this may cause damage.
5. DO NOT USE POWER TOOLS TO ASSEMBLE THIS PRODUCT.
6. Always place the product on a flat, level surface.
7. Do not sit or stand on the partially assembled product; only use the product for which it is intended.

CARE AND MAINTENANCE

- Use a slightly damp cloth to clean the product. Do not use bleach or abrasive cleaning material.
- Check all the fittings periodically and re-tighten as necessary. Do not use the product if any of the parts is damaged or broken.
- Never allow any kind of liquid to remain on your furniture. Absorption can cause wood to warp or delaminate.
- Do not place hot items (e.g., hot drinks) directly onto the wood surface.
- Do not drag and/or pull the furniture.

This product is for indoor, and household use only - not for commercial use.

ASSEMBLY INSTRUCTIONS ROUND DINING TABLE

Parts and Hardware List



Table Top
A. 1PC



Top Ring
B. 1PC



Bottom Base Ring
C. 1PC



Tube With Nut
D. 6PCS



Tube
E. 6PCS

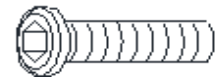

25mm Screw
F. 12PCS

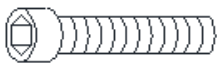

1/4 x 38mm Hex Screw
G. 4PCS



Spring washer
H. 4PCS



Black Spacer
I. 4PCS



Leg Stud
J. 4PCS



Allen Key
K. 1PC

STEP 1

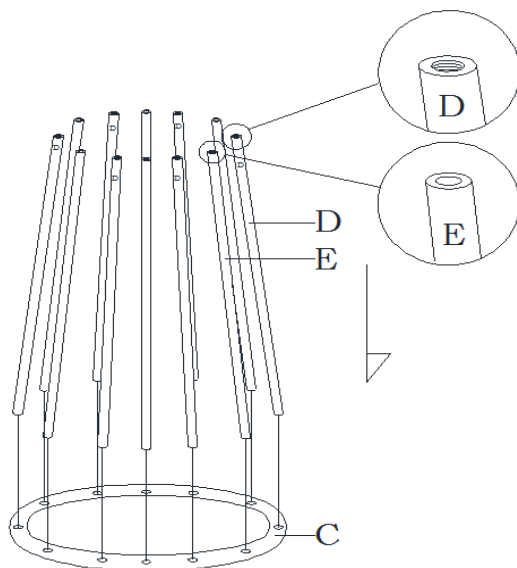

Insert Tube (E) and Tube With Nut (D) alternately into holes on Bottom Base Ring (C) as shown.

STEP 2

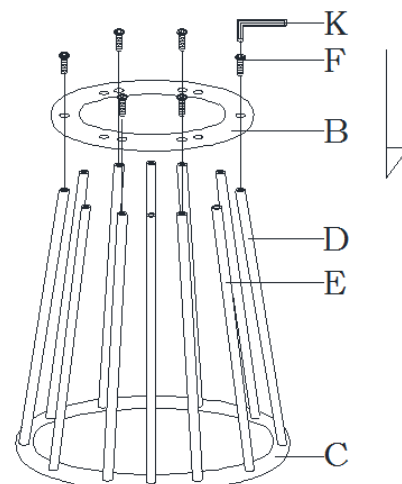

- a) Position Top Ring (B) as shown to align screw holes on (B) to Tube (D) and also fit Tube (E).
- b) Use Screw (F) to loosely fasten (B) to (D). Do not tighten (F) completely until all screws are in place.
Use Allen Key (K) to drive and tighten (F).

ASSEMBLY INSTRUCTIONS ROUND DINING TABLE

STEP 3

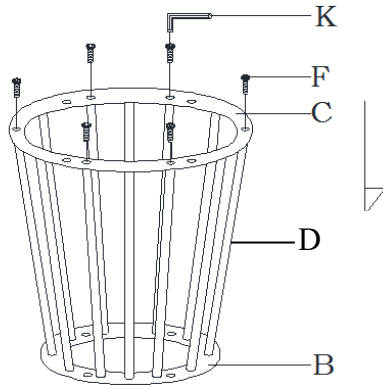

- a) Position the assembly from STEP 2 with the Bottom Base Ring (C) facing up as shown.
- b) Use Screw (F) to loosely fasten (C) to (D). Do not tighten (F) completely until all screws are in place. Use Allen Key (K) to drive and tighten (F).

STEP 4

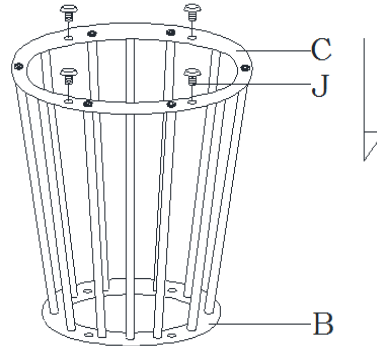

Screw in Threaded Leg Stud (J) into designated holes on (C).

STEP 5

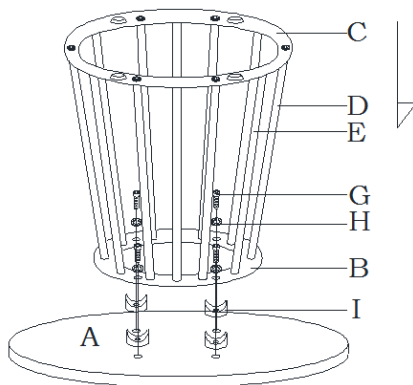

- a) Lay Table Top (A) bottom-side up flat on a material that does not scratch or damage the part.
- b) Position Spacer (I) to align screw hole on (I) to Table Top (A).
- c) Insert Screw (G) fitted with Spring Washer (H) through screw hole on Top Ring (B) and Spacer (I) to fasten onto (A).
- d) Use Allen Key (K) to drive (G). Do not tighten (G) completely until all 4 screws are in place.

STEP 6

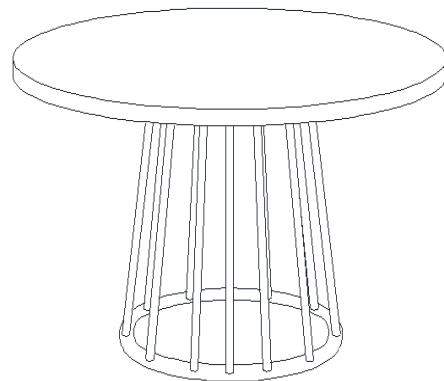

With assistance, set the table right-side up.

The assembly of the table is complete.