

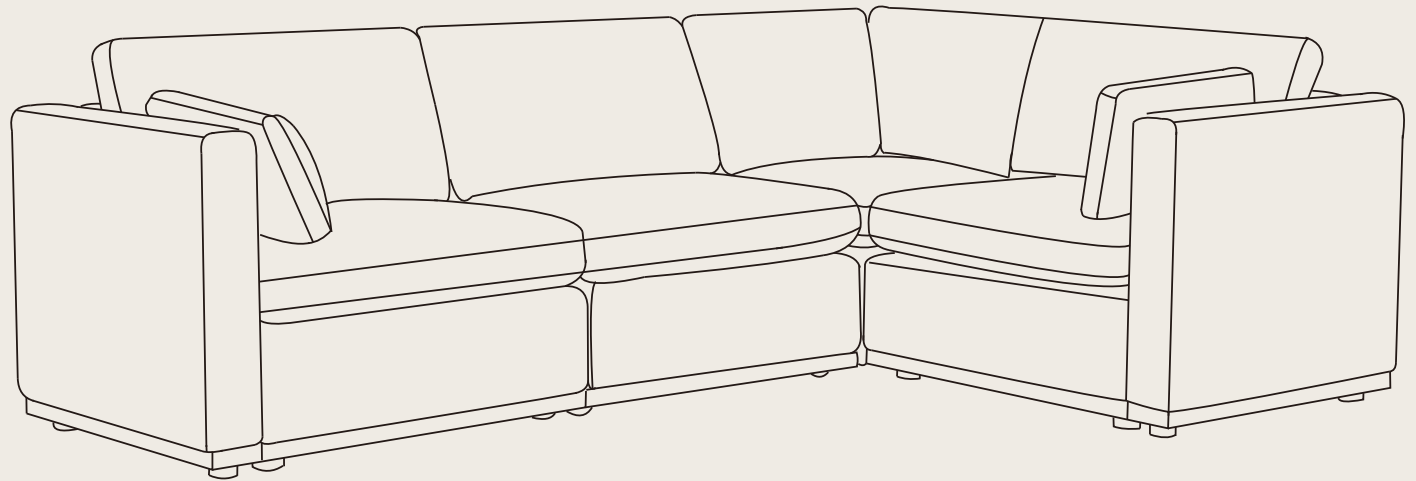

# Assembly Manual

## Modular Sofa



### Follow Us

 @chitalivingofficial

 @chitaliving

 @chitaliving

 @chitaliving

If at any step you need a helping hand, we're always here for you. You can email us, or hop into a live chat on our website — whatever method is convenient for you.

 [support@chitaliving.com](mailto:support@chitaliving.com)





Thank you for purchasing from CHITA LIVING. Please read this manual carefully before using and keep this manual for future reference. The design and/or specification of this product is subject to change without notice.

# Welcome to CHITA LIVING

If you are reading these instructions, the hard part is already out of the way. Surrounded by all these boxes, you may feel a little overwhelmed. No worries, we will walk you through and you will find the assembly process easy, intuitive and mostly, fun. Here are some tips before you get started.

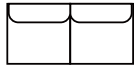
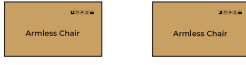
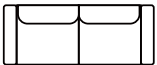
1. Count the boxes. Check if you have received all boxes using the diagram on next page. Do not start the assembly process until all boxes are present. If you have not received all boxes or received wrong boxes, please contact our customer service at [support@chitaliving.com](mailto:support@chitaliving.com) and we will get back to you. Do not discard any of the packaging until you are certain that you have all the necessary parts for the assembly.
2. Do not open all boxes at once. Start with Arms Box and Left Seat & Backrest Box to assemble the Left Armchair. Then, move on to open the Right Seat & Backrest Box to assemble the Right Armchair. Next, assemble the Armless Chair, and finally, the Ottoman.
3. After the assembly is complete, feel free to enjoy your modular sofa as much as you can. However, please ensure that the packaging is disposed of in a safe and environmentally responsible way.
4. For your safety (as well as sofa's), do not sit on the backrest during and after assembly and never use this sofa as a step ladder.

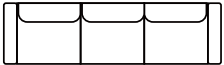
**!** Do not start the assembly process until all boxes are present.

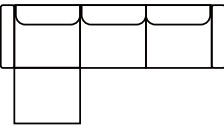
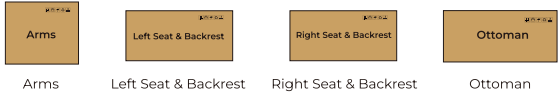
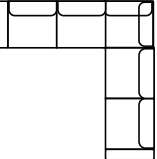
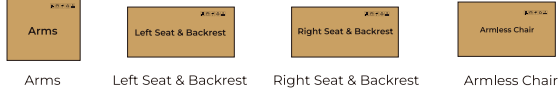
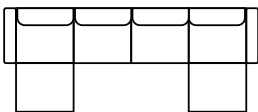
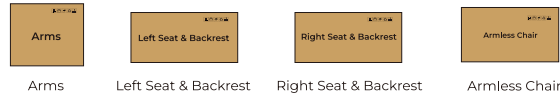
<p><b>2-piece Armless</b></p> 	<p>Box × 2</p>  <p>Armless Chair    Armless Chair</p>
<p><b>2-piece</b></p> 	<p>Box × 3</p>  <p>Arms    Left Seat &amp; Backrest    Right Seat &amp; Backrest</p>
<p><b>3-piece</b></p> 	<p>Box × 4</p>  <p>Arms    Left Seat &amp; Backrest    Right Seat &amp; Backrest    Armless Chair</p>
<p><b>4-piece</b></p> 	<p>Box × 5</p>  <p>Arms    Left Seat &amp; Backrest    Right Seat &amp; Backrest    Ottoman    Armless Chair</p>
<p><b>5-piece</b></p> 	<p>Box × 7</p>  <p>Arms    Left Seat &amp; Backrest    Right Seat &amp; Backrest    Armless Chair    Corner Backs    Corner Seat &amp; Cushions</p>
<p><b>6-piece</b></p> 	<p>Box × 7</p>  <p>Arms    Left Seat &amp; Backrest    Right Seat &amp; Backrest    Armless Chair    Ottoman    Ottoman    Ottoman</p>

## Assembly Manual

### Left Armchair

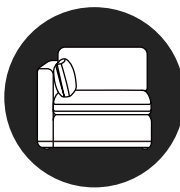

#### Parts

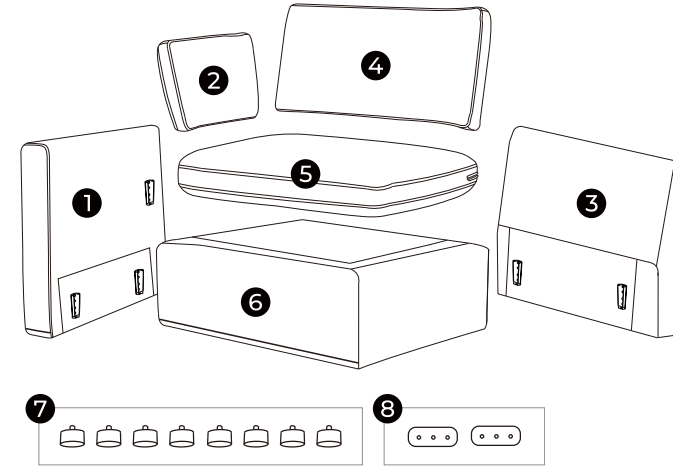

- 1 Left Arm
- 2 Arm Pillow
- 3 Left Backrest
- 4 Back Cushion
- 5 Seat Cushion
- 6 Left Seat Base
- 7 Leg × 8
- 8 Connector × 2

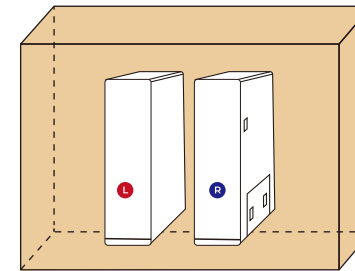

#### Arms PIECES INCLUDED

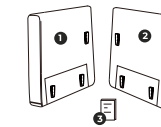

- 1 Left Arm x 1
- 2 Right Arm x 1
- 3 Assembly Manual x 1

**Note:** Left & Right Arms are packed together in Arms Box.

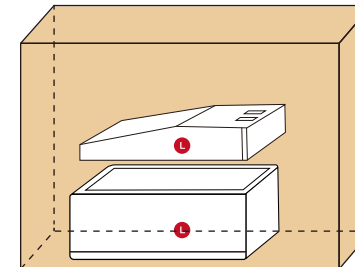

#### Left Seat & Backrest PIECES INCLUDED

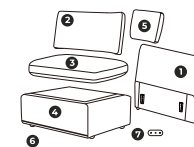

- 1 Backrest x 1
- 2 Back Cushion x 1
- 3 Seat Cushion x 1
- 4 Seat Base x 1
- 5 Arm Pillow x 1
- 6 Leg x 8
- 7 Connector x 2

## Assembly Manual

### Left Armchair

#### Step 1

Take out the Left Arm (L) from Arms Box.

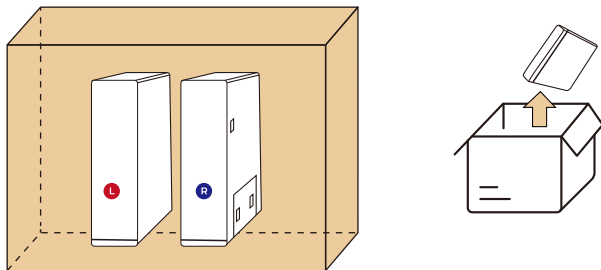

#### Step 2

Take out the Left Seat and Backrest from Left Seat & Backrest Box.

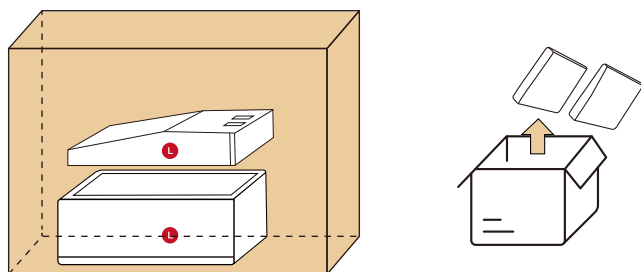

#### Step 3

Remove the three wood sticks at the base of the seat to take out the Seat Cushion, Back Cushion, Arm Pillow, and Metal Connectors (2 pieces).

⚠ Remove the sticks one by one. Push the stick down and rotate it towards the corner of the base and pull it out. Once all sticks are out, take out the cushions carefully.

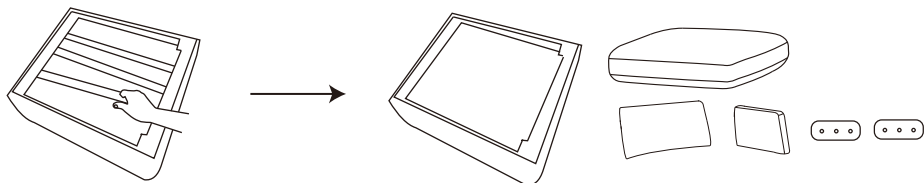

## Assembly Manual

### Left Armchair

#### Step 4

Take out the Legs (8 pieces) from the bottom of the Backrest.

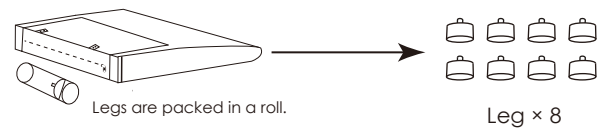

#### Step 5

Rotate the Legs firmly.

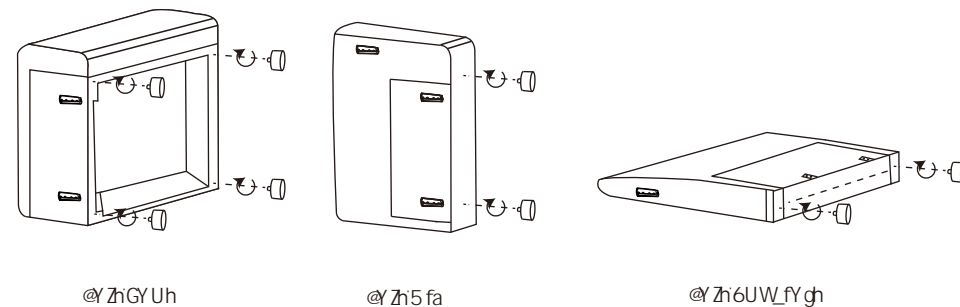

#### Step 6

Slide the Left Backrest into the Left Seat.

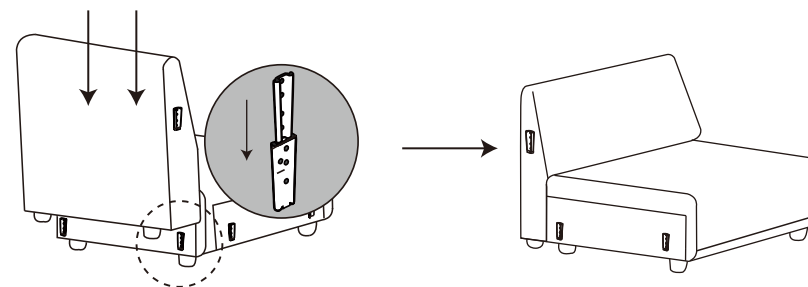

## Assembly Manual

### Left Armchair

#### Step 7

Slide the Left Arm into the Left Seat and Backrest.

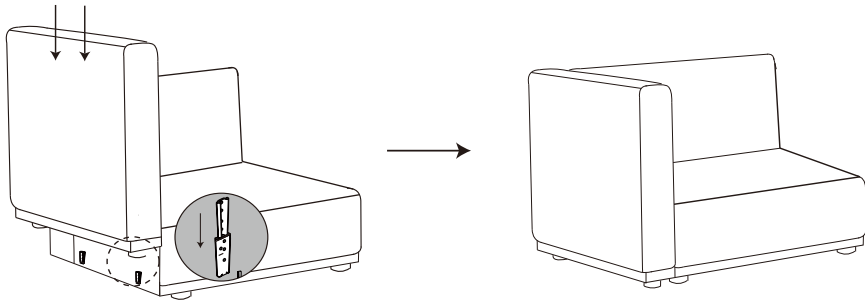

#### Step 8

Fluff the Seat Cushion, Back Cushion and Arm Pillow, and put them on the chair to complete the assembly of your Left Armchair.

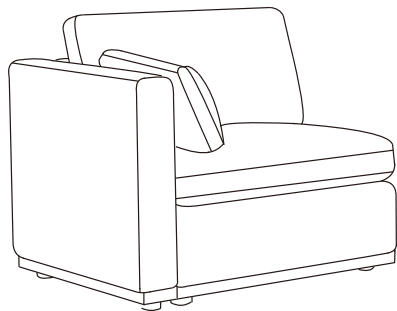

Congratulations!  
Left Armchair is ready!

#### Tips

For now, please keep the Metal Connectors aside and you may need them after you have completed the assembly of all modules (See Page 23 to 25 for details).

## Assembly Manual

### Right Armchair



#### Parts

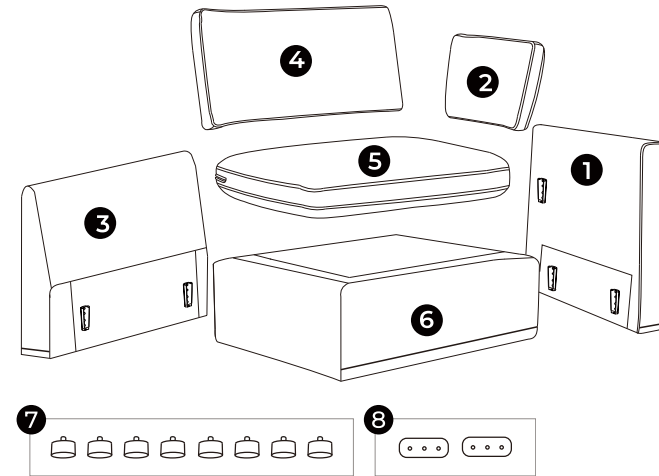

- ① Right Arm
- ② Arm Pillow
- ③ Right Backrest
- ④ Back Cushion
- ⑤ Seat Cushion
- ⑥ Right Seat Base
- ⑦ Leg x 8
- ⑧ Connector x 2

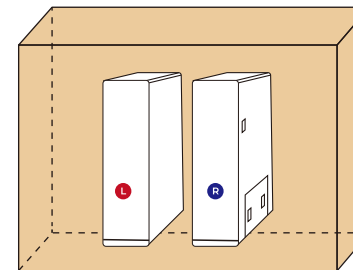

#### Arms PIECES INCLUDED

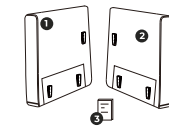

- ① Left Arm x 1
- ② Right Arm x 1
- ③ Assembly Manual x 1

**Note:** Left & Right Arms are packed together in Arms Box.

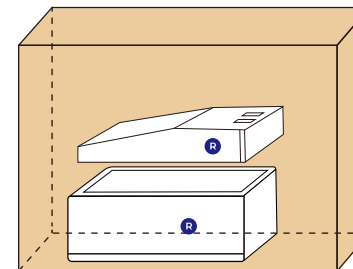

#### Right Seat & Backrest PIECES INCLUDED

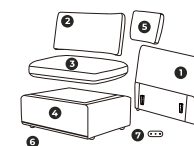

- ① Backrest x 1
- ② Back Cushion x 1
- ③ Seat Cushion x 1
- ④ Seat Base x 1
- ⑤ Arm Pillow x 1
- ⑥ Leg x 8
- ⑦ Connector x 2

# Assembly Manual

## Right Armchair

### Step 1

Take out the Right Arm (R) from Arms Box.

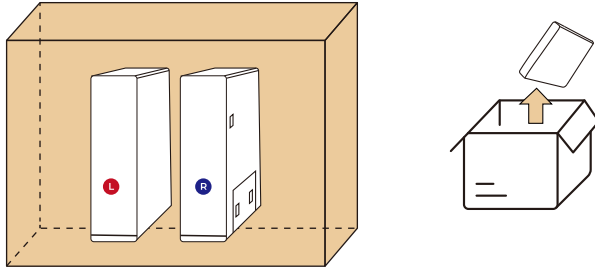

### Step 2

Take out the Right Seat and Backrest from Right Seat & Backrest Box.

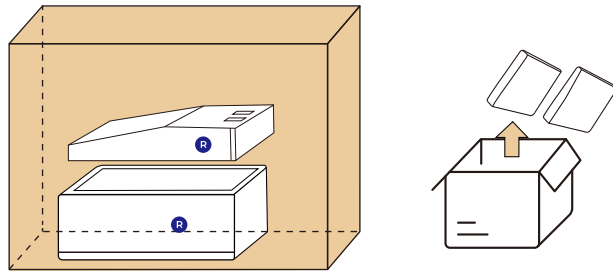

### Step 3

Remove the three wood sticks at the base of the seat to take out the Seat Cushion, Back Cushion, Arm Pillow, and Metal Connectors (2 pieces).

⚠ Remove the sticks one by one. Push the stick down and rotate it towards the corner of the base and pull it out. Once all sticks are out, take out the cushions carefully.

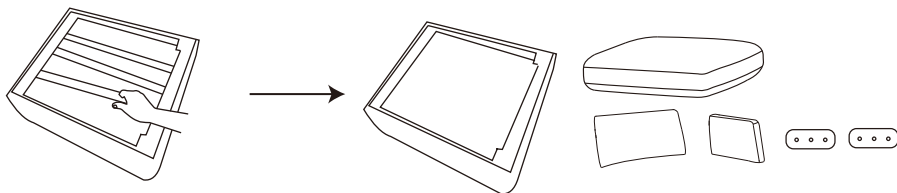

# Assembly Manual

## Right Armchair

### Step 4

Take out the Legs (8 pieces) from the bottom of the Backrest.

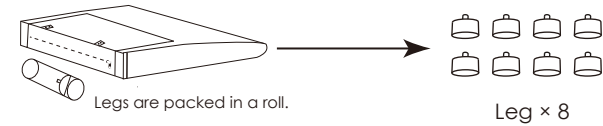

### Step 5

Rotate the Legs firmly.

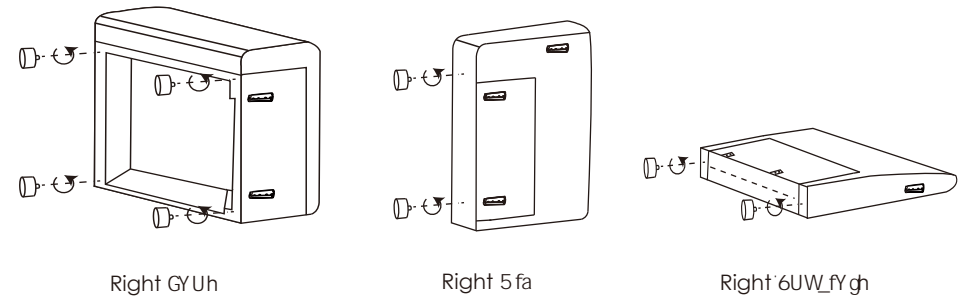

### Step 6

Slide the Right Backrest into the Right Seat.

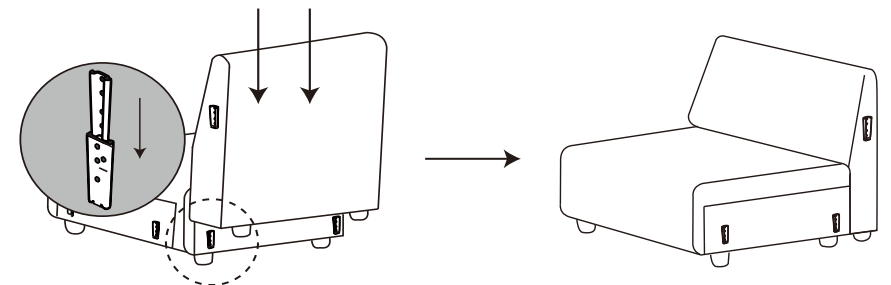

# Assembly Manual

## Right Armchair

### Step 7

Slide the Right Arm into the Right Seat and Backrest.

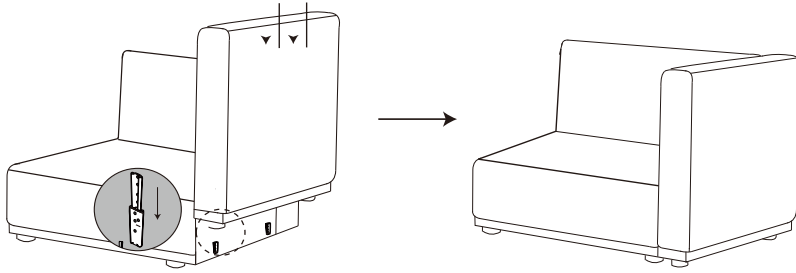

### Step 8

Fluff the Seat Cushion, Back Cushion and Arm Pillow, and put them on the chair to complete the assembly of your Right Armchair.

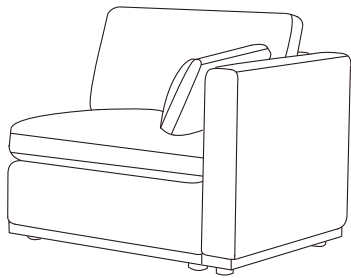

Congratulations!  
Right Armchair is ready!

### Tips

For now, please keep the Metal Connectors aside and you may need them after you have completed the assembly of all modules (See Page 23 to 25 for details).

# Assembly Manual

## Armless Chair



### Parts

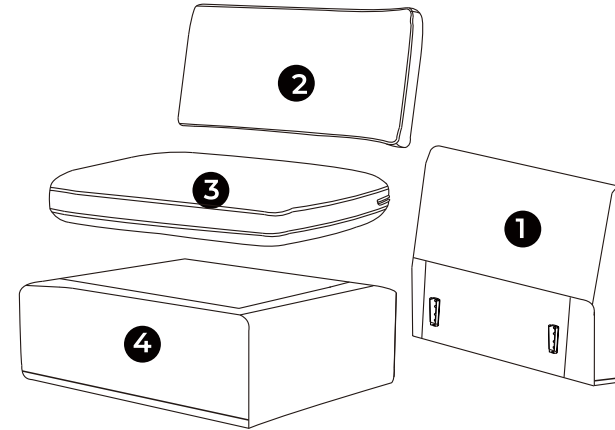

- 1 Backrest
- 2 Back Cushion
- 3 Seat Cushion
- 4 Seat Base
- 5 Leg x 6
- 6 Connector x 2

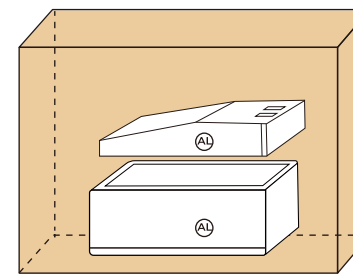

### Armless Chair PIECES INCLUDED

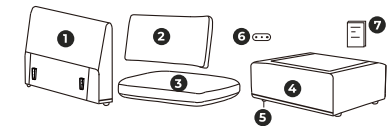

- 1 Backrest x 1
- 2 Back Cushion x 1
- 3 Seat Cushion x 1
- 4 Seat Base x 1
- 5 Leg x 6
- 6 Connector x 2
- 7 Assembly Manual x 1

# Assembly Manual

## Armless Chair

### Step 1

Take out the Seat and Backrest from Armless Chair Box.

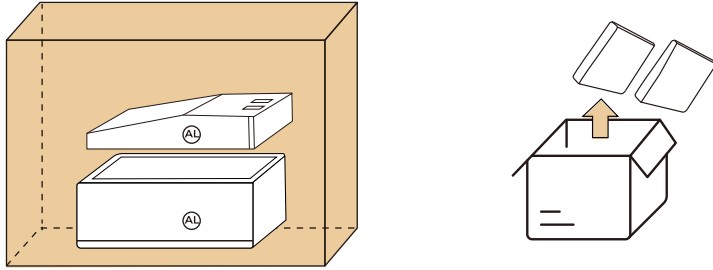

### Step 2

Remove the three wood sticks at the base of the seat to take out the Seat Cushion, Back Cushion, and Metal Connectors (2 pieces).

⚠ Remove the sticks one by one. Push the stick down and rotate it towards the corner of the base and pull it out. Once all sticks are out, take out the cushions carefully.

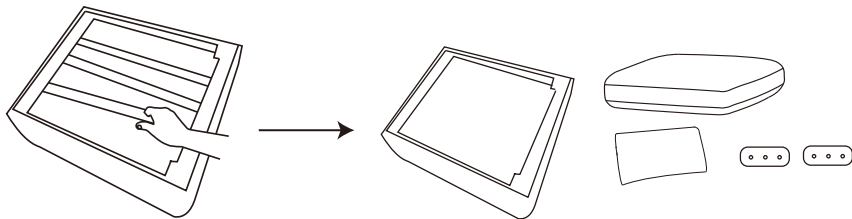

# Assembly Manual

## Armless Chair

### Step 3

Take out the Legs (6 pieces) from the bottom of the Backrest.

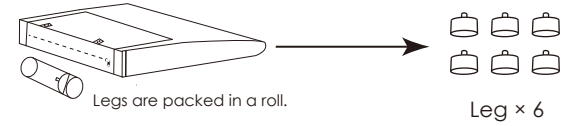

### Step 4

Rotate the Legs firmly.

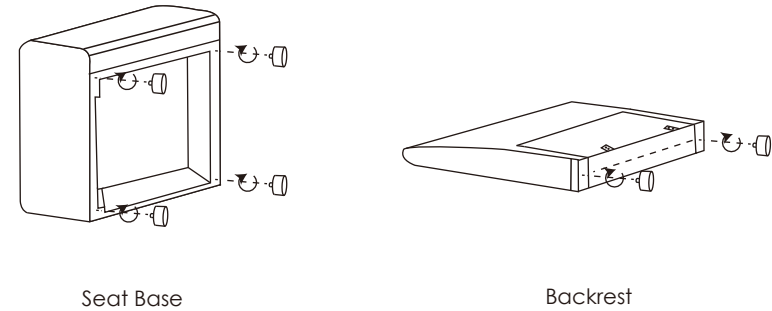

### Step 5

Slide the Backrest into the Seat.

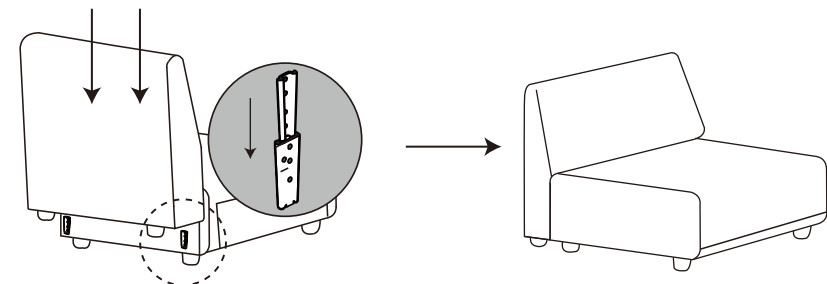

# Assembly Manual

## Armless Chair

### Step 6

Fluff the Seat Cushion and Back Cushion, and put them on the chair to complete the assembly of your Armless Chair.

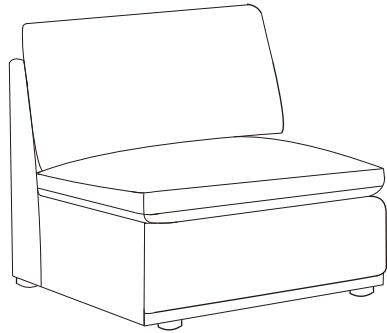

Congratulations!  
Armless Chair is ready!

### Tips

For now, please keep the Metal Connectors aside and you may need them after you have completed the assembly of all modules (See Page 23 to 25 for details).

# Assembly Manual

## Corner



### Parts

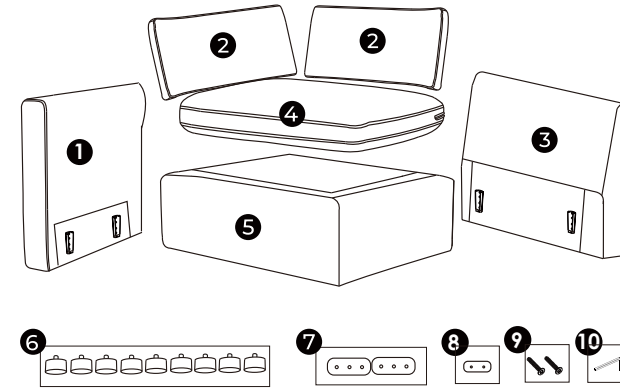

- 1 Short Back C1
- 2 Back Cushion × 2
- 3 Regular Back C2
- 4 Seat Cushion
- 5 Seat Base
- 6 Leg × 9
- 7 Bottom Connector × 2
- 8 Back Connector
- 9 Bolt × 2
- 10 Allen Key

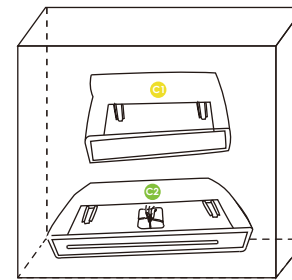

### Corner Back PIECES INCLUDED

- 1 Short Back C1
- 2 Regular Back C2
- 3 Leg × 9

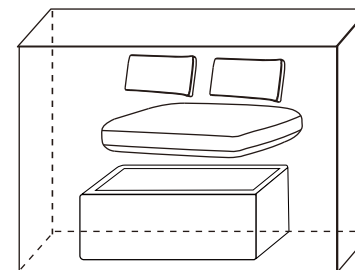

### Corner Seat & Cushions PIECES INCLUDED

- 1 Back Cushion × 2
- 2 Seat Cushion
- 3 Seat Base
- 4 Bottom Connector × 2
- 5 Back Connector
- 6 Bolt × 2
- 7 Allen Key
- 8 Assembly Manual



# Assembly Manual

## Corner

### Step 1

Take out the Short Back (C1) and Regular Back (C2) from Corner Backs Box.

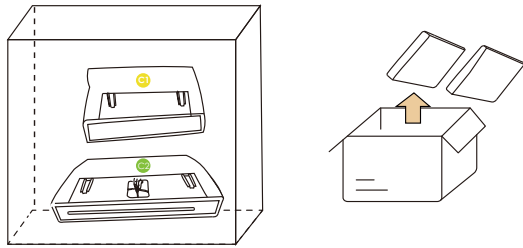

### Step 2

Take out the Seat Base and Back Cushions (2 pieces) from the Corner Seat & Cushions Box.

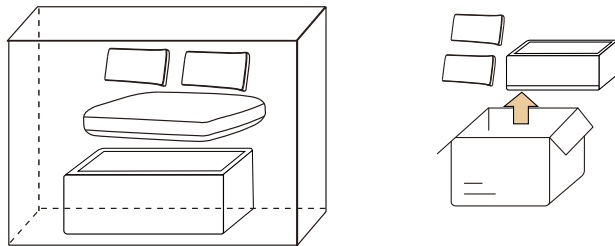

### Step 3

Take out the Seat Cushion, Bottom Connectors (2 piece), Back Connector (1 piece), Bolts (2 pieces) and Allen Key (1 piece) from the bottom of the Seat Base.

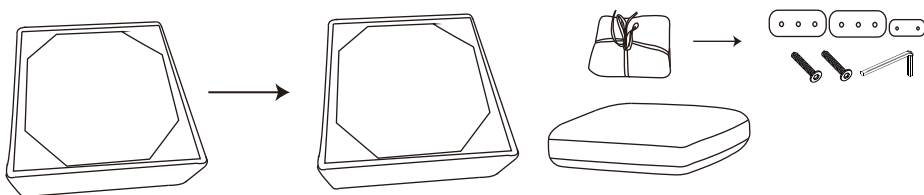

# Assembly Manual

## Corner

### Step 4

Take out the Legs (9 pieces) from the bottom of the Regular Back(C2).

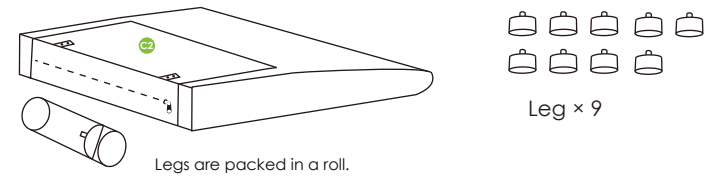

### Step 5

Rotate the Legs firmly.

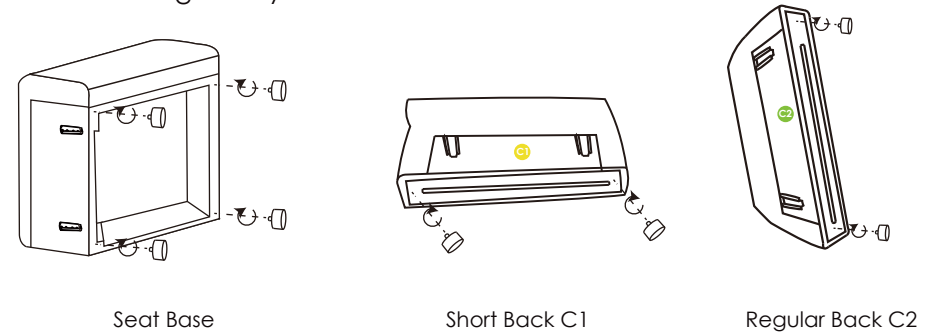

### Step 6

Slide the Short Back (C1) into the side of Seat Base marked with C1.

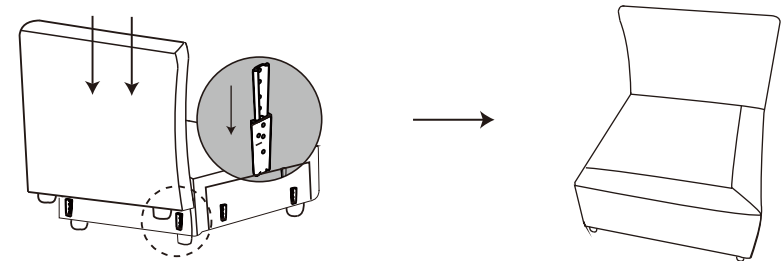

## Assembly Manual

### Corner

#### Step 7

Slide the Regular Back (C2) into the side of Seat Base marked with C2.

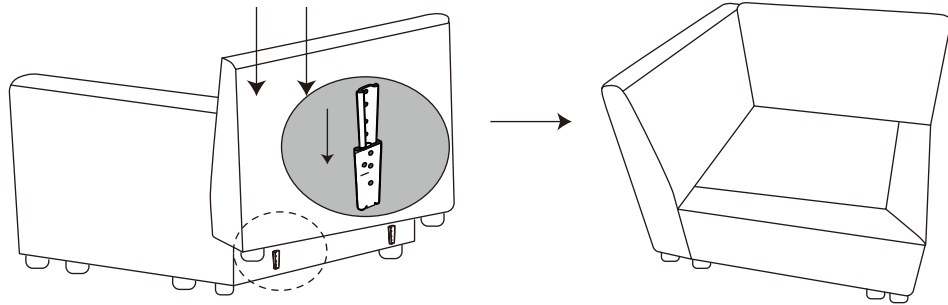

#### Step 8

Gently place the corner in the upright position. Attach the Back Connector, using Bolts and Allen Key. Loosely attach the bolts to get the alignment right, rather than fully tightening one before the other. After both bolts are aligned, fully tighten all bolts.

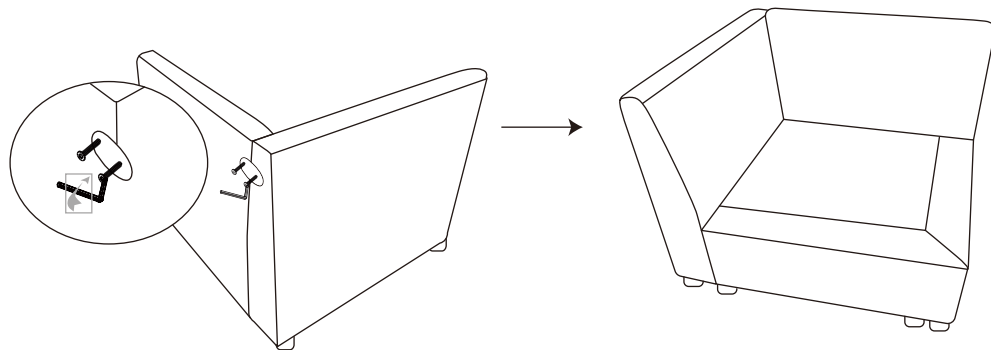

## Assembly Manual

### Corner

#### Step 9

Fluff the Seat Cushion and Back Cushions, and put them on the corner to complete the assembly.

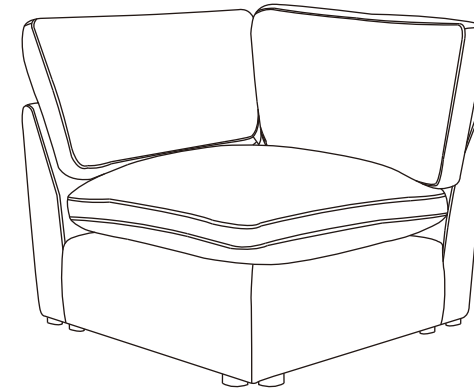

Congratulations!  
Corner is ready!

#### Tips

For now, please keep the Metal Connectors aside and you may need them after you have completed the assembly of all modules (See Page 23 to 25 for details).

# Assembly Manual

## Ottoman

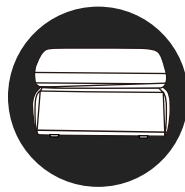

### Parts

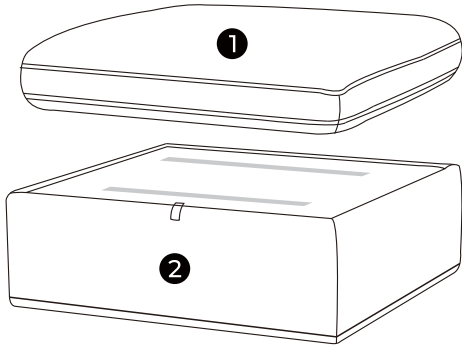

1 Seat Cushion

2 Seat Base

3 Leg

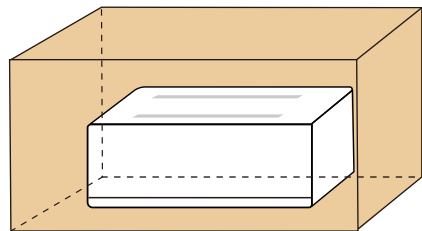
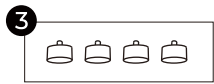

### Ottoman PIECES INCLUDED

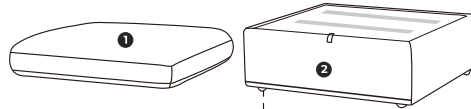

1 Seat Cushion x 1

2 Seat Base x 1

3 Leg x 4

4 Assembly Manual x 1

# Assembly Manual

## Ottoman

### Step 1

Take out the Seat Base from Ottoman Box.

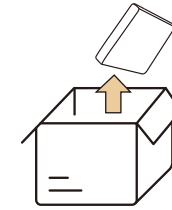
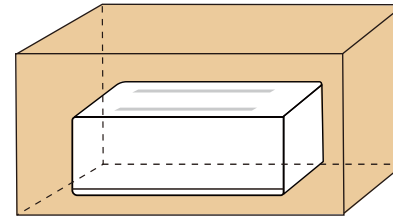

### Step 2

Lift up the lid of the storage to take out Seat Cushion and Legs (4 pieces).

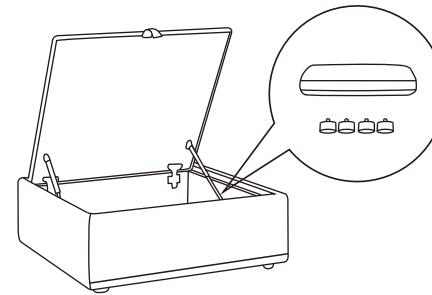

### Step 3

Rotate the Legs firmly.

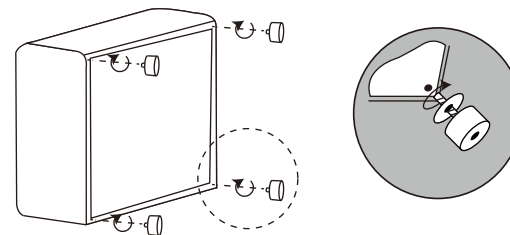

## Assembly Manual

### Ottoman

#### Step 4

Remove the velcro protectors on the top of the Seat.

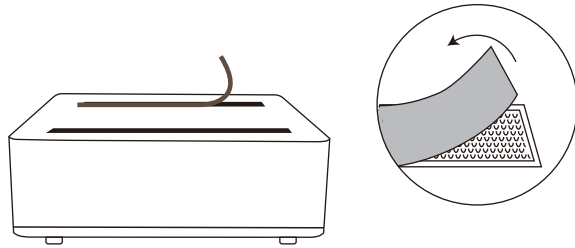

#### Step 5

Fluff the Seat Cushion. Attach it to the Seat Base to complete the assembly of your Ottoman.

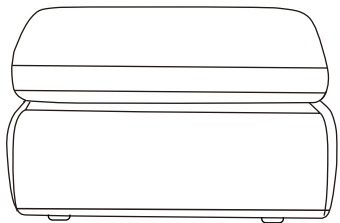

Congratulations!  
Your Ottoman is ready!

## Bonus Feature



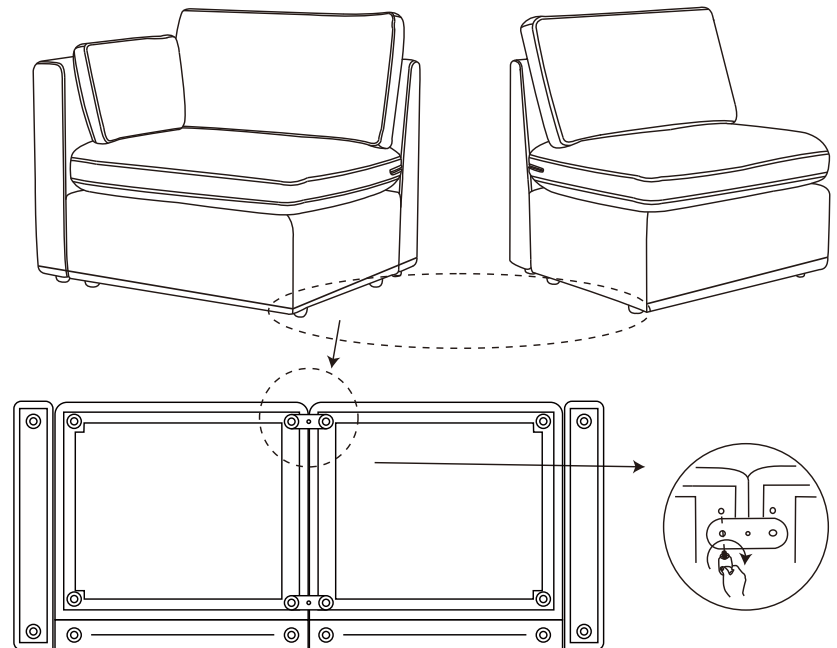

Now you have successfully completed the assembly of each module. Based on the number of modules you purchased, you may remix your modular sofa in multiple configurations. In the diagrams on following pages, there are several configurations for your reference. After you decide which configuration you love the most, you may connect the chairs with Metal Connectors. In addition to non-slip legs, these Metal Connectors are provided to further help prevent the chairs from sliding apart.

**Step 1:** Put the chairs side by side, with the base of the chair facing you.  
**Step 2:** Attach the Metal Connectors by screwing on the legs firmly. You may have a few extra Metal Connectors left over. They are included in case you want to connect additional modules in the future. We recommend storing them in the little zip-top bag in case you decide to expand your sofa later.

**Note:** Ottoman is a standalone piece and cannot be attached to any chair with Metal Connectors.

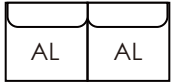
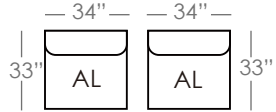

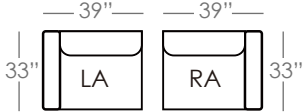
# Modular Sofa Multiple Congurations

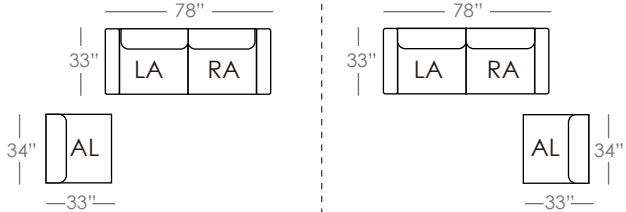
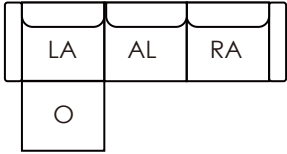
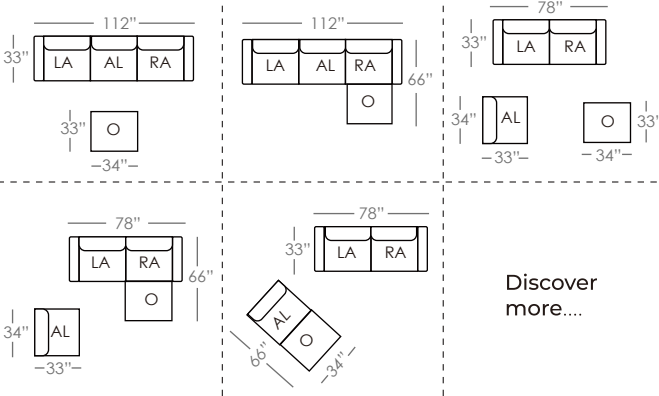
<p><b>2-piece Armless</b></p>  <p>W 68" x D 33" x H 35"</p>	
<p><b>2-piece Sofa</b></p>  <p>W 78" x D 33" x H 35"</p>	
<p><b>3-piece Sofa</b></p>  <p>W 112" x D 33" x H 35"</p>	
<p><b>4-piece Sofa-Chaise</b></p>  <p>W 112" x D 66" x H 35"</p>	 <p>Discover more....</p>

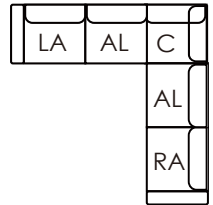
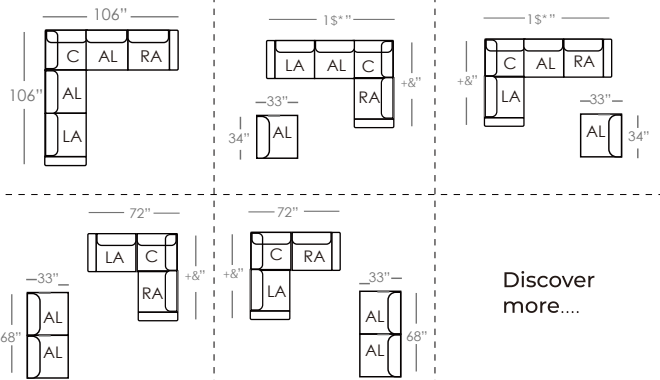
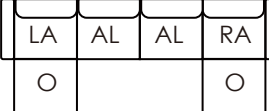
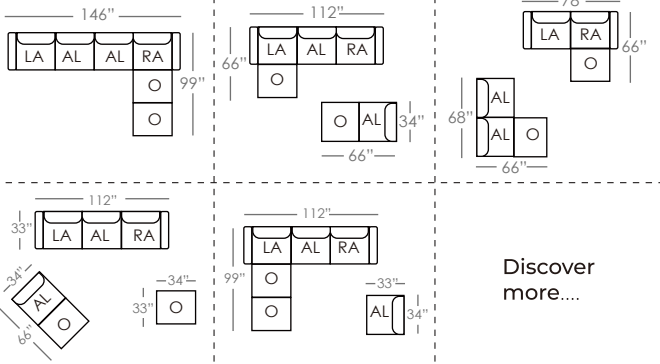
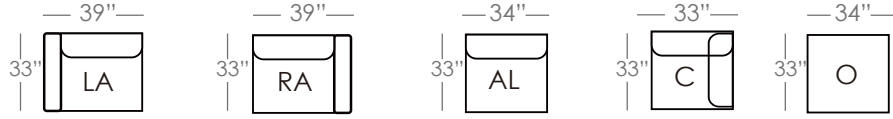
<p><b>5-piece Modular Sectional</b></p>  <p>W 106" x D 106" x H 35"</p>	 <p>Discover more....</p>
<p><b>6-piece Modular Sectional</b></p>  <p>W 146" x D 66" x H 35"</p>	 <p>Discover more....</p>
 <p>Left Armchair    Right Armchair    Armless Chair    Corner    Ottoman</p>	

## Care Instruction

### For non-removable areas:

Blot and spot clean immediately with a damp white cloth and a water-based cleaner or upholstery shampoo (Cleaning Code: W).

### For cushion covers:

Machine washable in cold, gentle cycle and hang to dry.

🧺 Wash using cold water (86°F / 30°C or below).

⊠ Do not bleach.

⊠ Do not tumble dry.

☑ Hang to dry.

🧊 Iron at low temperature (230°F / 110°C or below).

Ⓟ Dry clean using Tetrachloroethylene (PCE).

