

# ASSEMBLY INSTRUCTION

## SPIRAL TUBE METAL QUEEN BED

**A** Headboard

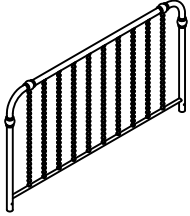

1pc

**B** Footboard

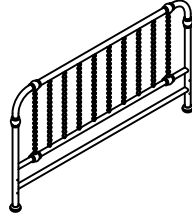

1pc

**C** Extension leg

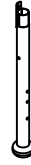

2pcs

**D** Bar

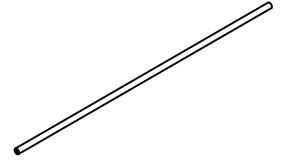

1pc

**E** Side rail

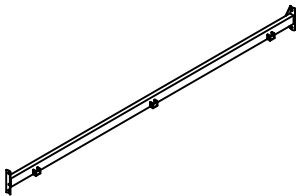

2pcs

**F** Slats

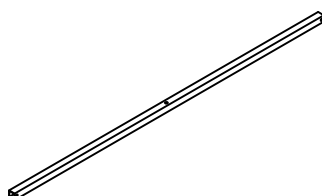

3pcs

**G** Support leg



3pcs

**H** Bolt  
1/4",57MM



6pcs

**I** Bolt  
1/4",44MM



9pcs

**J** Bolt  
1/4",19MM



6pcs

**K** Nut  
1/4"



10pcs

**L** Flat washer  
ø16mm



25pcs

**M** Allen wrench  
4X4MM



1pc

**N** Wrench  
11.3MM

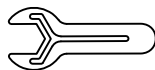

1pc

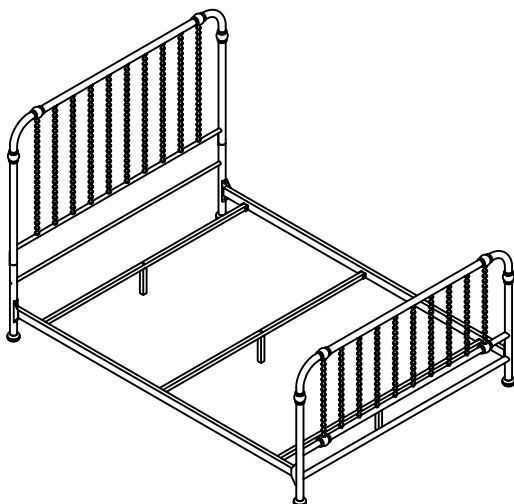

This page lists all the contents included in the box. Please take the time to identify the hardware as well as the individual components to this product. As you unpack and prepare for assembly, place the contents on a carpeted or padded area to protect them from damage.

**1** Assemble the bar (D) to the extension leg (C) with 2pcs bolts (H), then fastened using allen wrench (M).

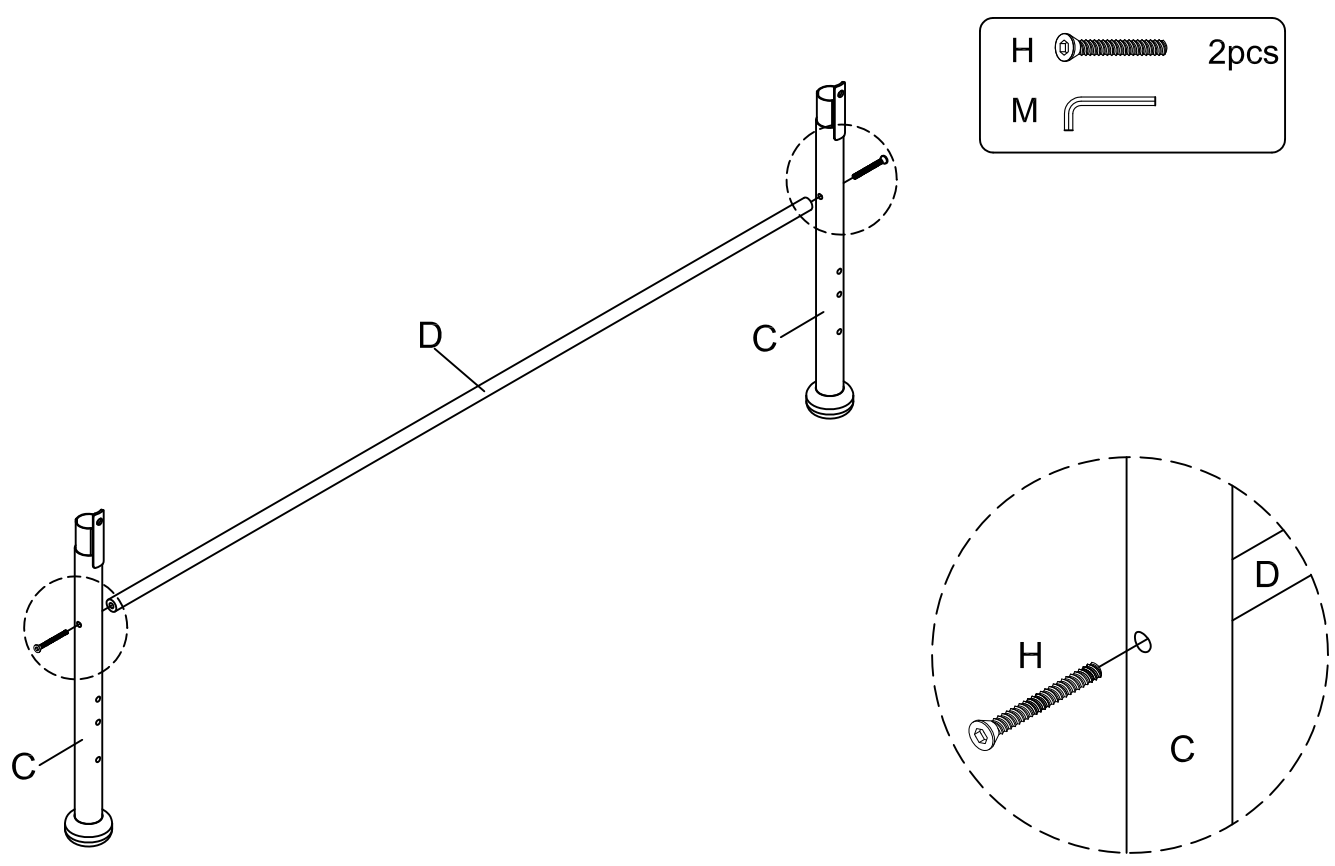

**2** Assemble the headboard (A) to the extension leg (C) with 2pcs bolt (J) and 2pcs flat washer (L), then fastened using allen wrench (M).

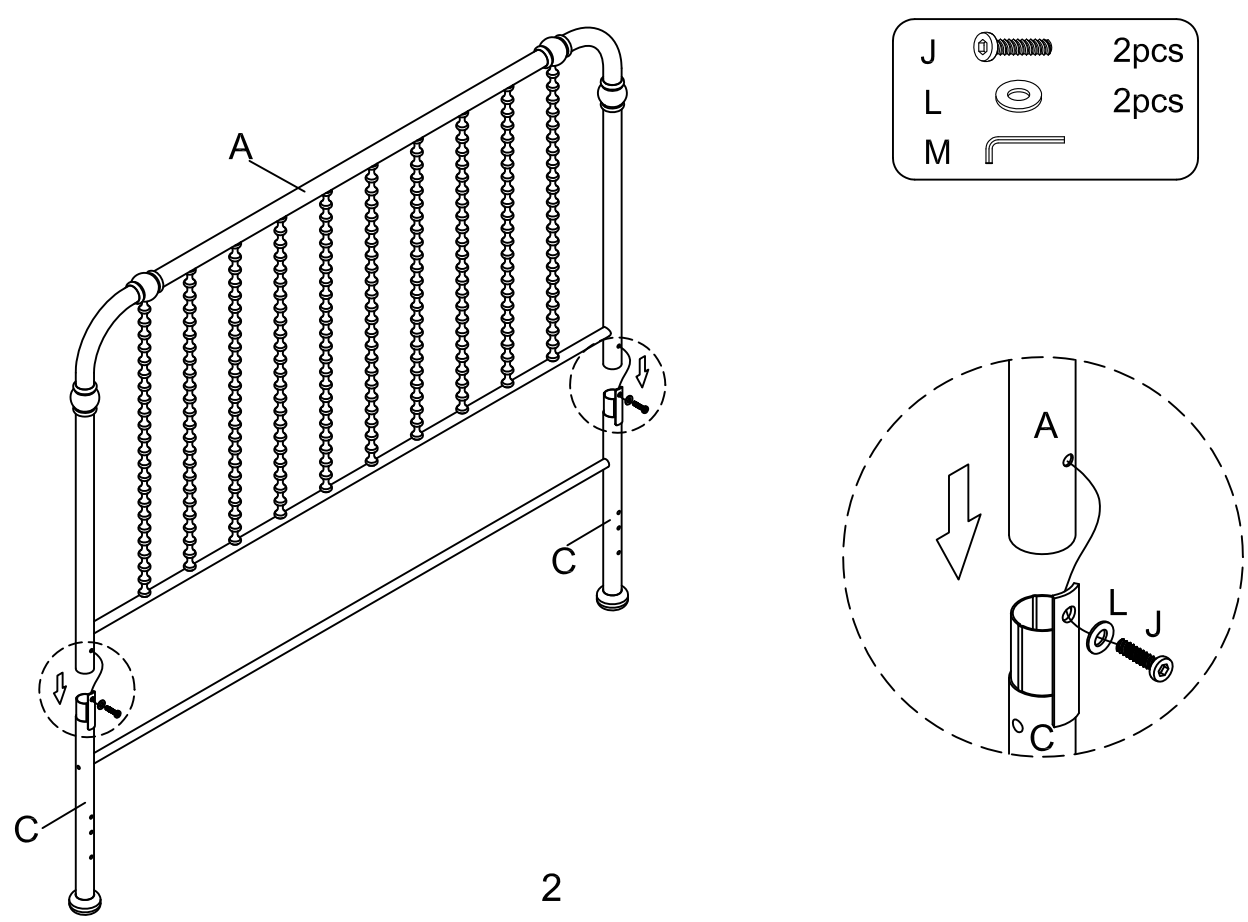

**3** Assemble the side rail (E) to the extension leg (C) and the footboard (B) with 4pcs bolts (H), 4pcs bolts (J), 4pcs nuts (K) and 8pcs flat washer (L), then fastened using allen wrench (M) and wrench (N).

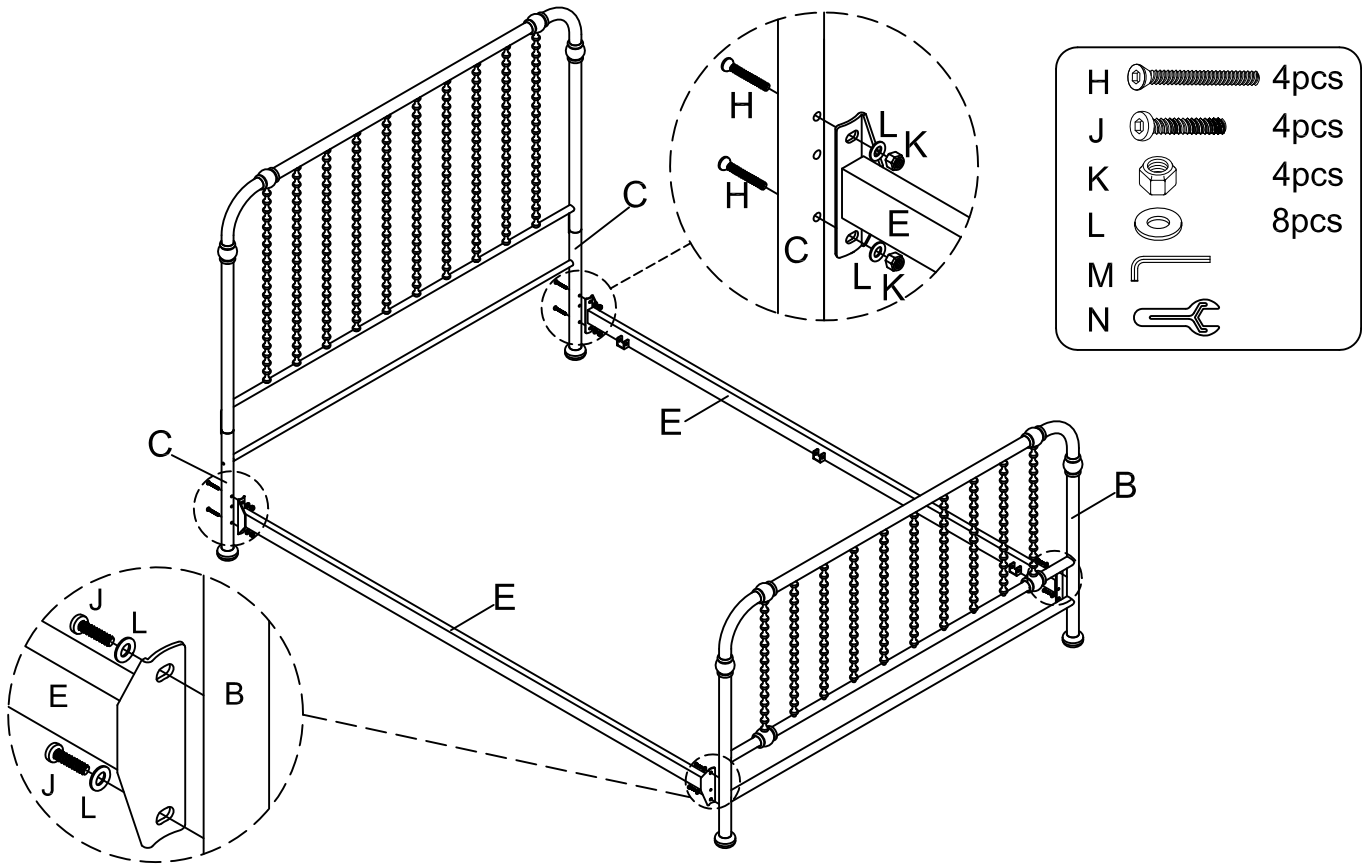



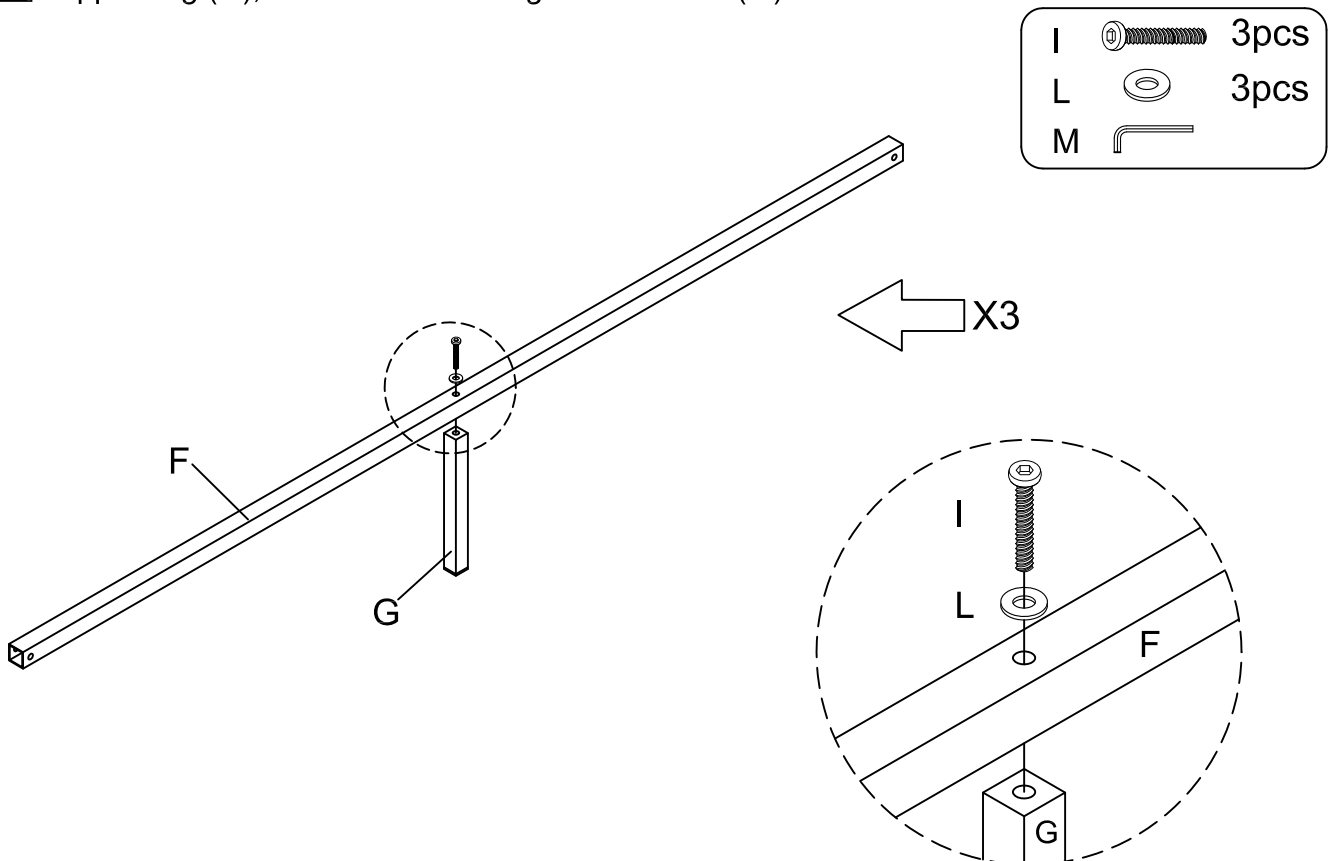



**4** Assemble the slat (F) to the support leg (G) with 1pc bolt (I) and 1pc flat washer (L) for each support leg (G), then fastened using allen wrench (M).

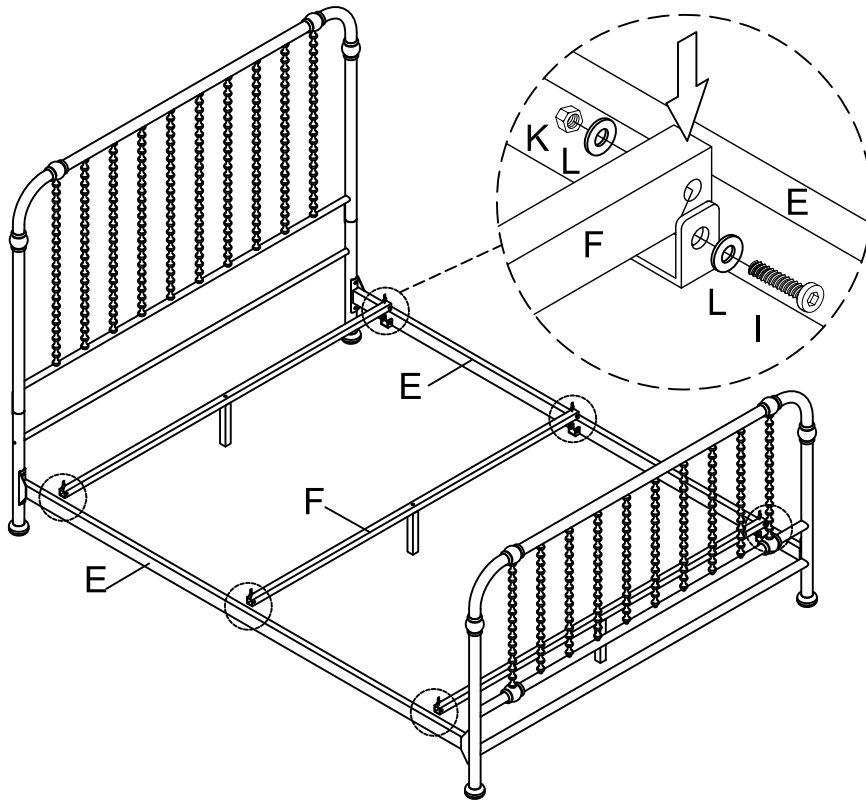

**5**

Assemble the slat (F) to the side rail (E) with 1 pc bolt (I), 1pc nut (K) and 2 pcs flat washer (L) for each end of slat (F), then fastened using allen wrench (M) and wrench (N).



I		6pcs
K		6pcs
L		12pcs
M		
N		

### Cleaning & Care

Treat surface with care. Surface is resistant to scratches but is not scratch resistant. Clean surfaces with a dry or damp soft cloth. Do not use abrasive cleaners. Hardware may loosen over time. Periodically check that all connections are tight.