

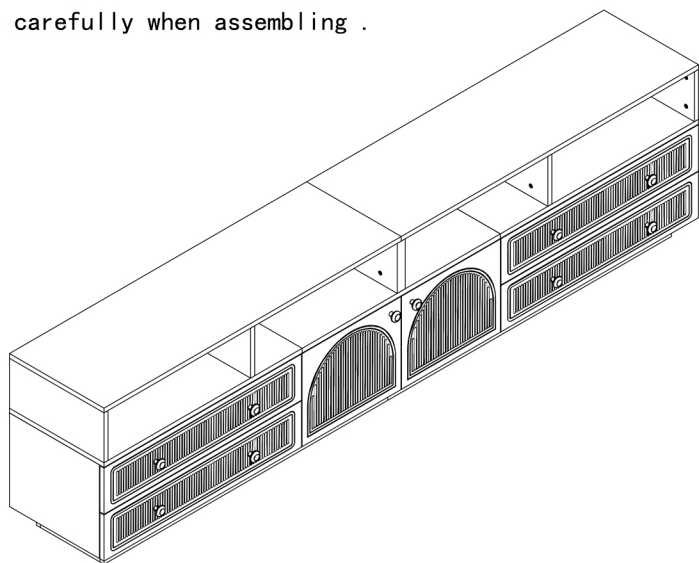

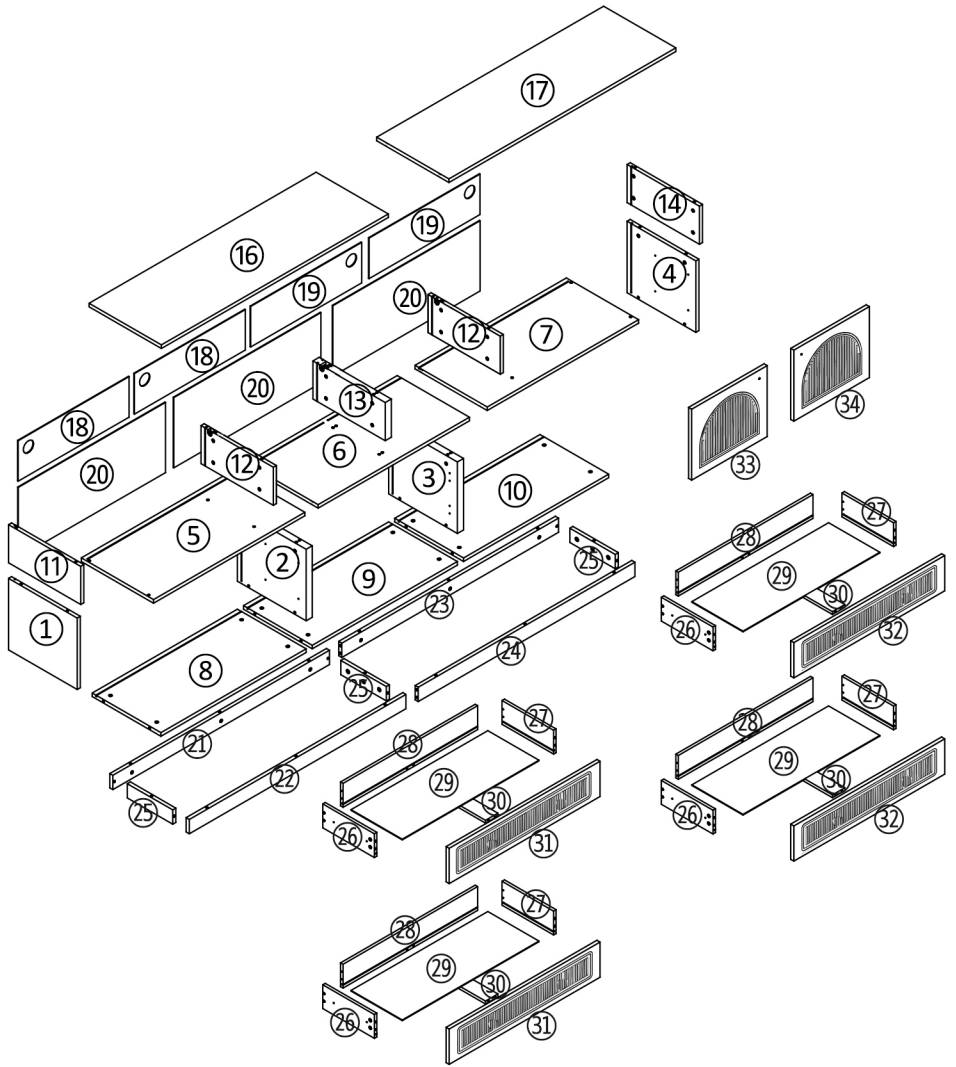













ASSEMBLY INSTRUCTION

- Read the assembly instructions carefully before beginning assembly.
- Ensure the safety of the glass during assembly.
- Do not over tighten the screws and bolts as this may damage the threads.
- Insert the screw into the hole as shown in the figure, follow the arrow in the picture, and then rotate 90° or 180° clockwise.
- Keep the small accessories in the accessory bag away from children.
- The remaining parts are spare parts.
- Kind tips: when installing the white backboard, install the white side inward.
- The operating instruction of RGB light is included in the package. Read it carefully when assembling .





A  69pcs	B  69pcs	A1  32pcs	B1  32pcs	C  3.5*14 60pcs	C8  3.5*12 24pcs	C9  4*30 16pcs	D  4pcs	E1  8*60 4pcs	F  10pcs
F1  10pcs	K  8pcs	Y  28pcs	AG  1pcs	AM  Decorative paper 48pcs	 LED				



Hardware installation demonstration

● Please make sure "A" hardware tightened and can't be pulled out

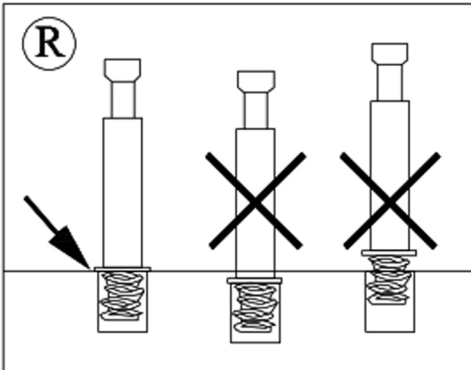
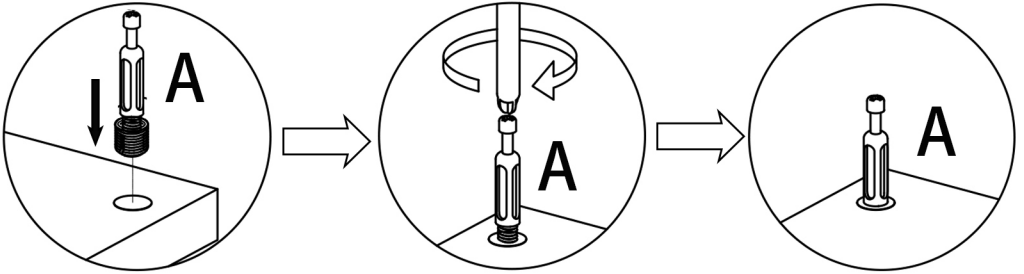



Hardware installation demonstration

- When inserting cam ensure arrowhead on cam points toward the hole on the panel edge

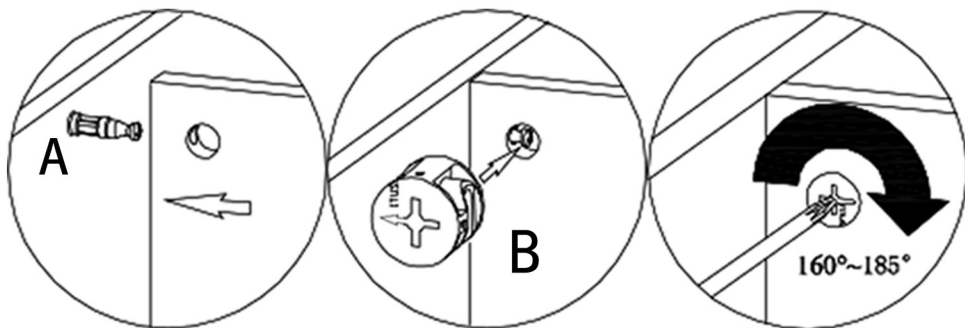



Hardware installation demonstration

- Please make sure "A" hardware tightened and can't be pulled out

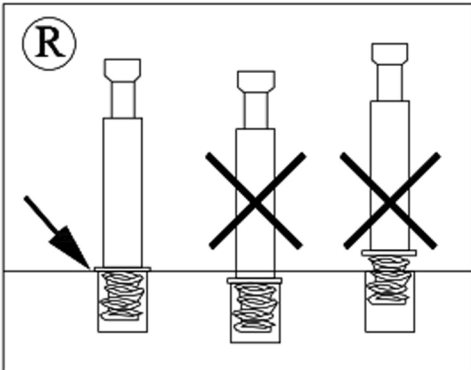
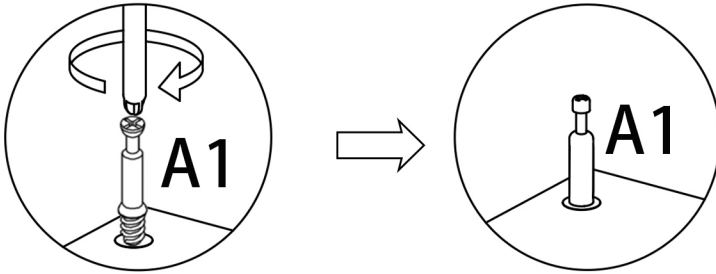



Hardware installation demonstration

- When inserting cam ensure arrowhead on cam points toward to the hole on the panel edge

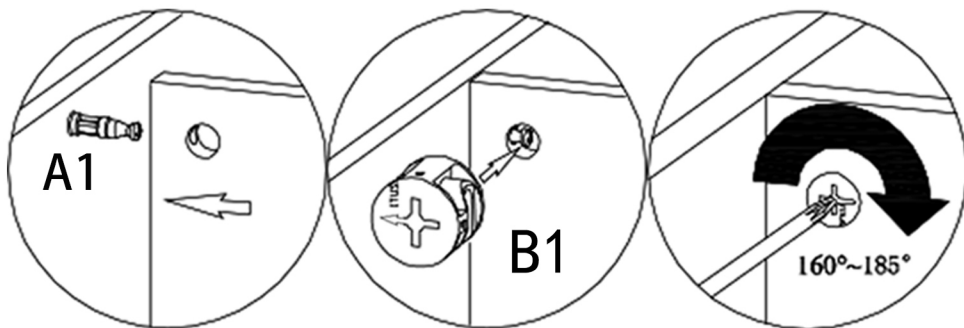



Hardware installation demonstration

Cabinet door front and rear adjustment

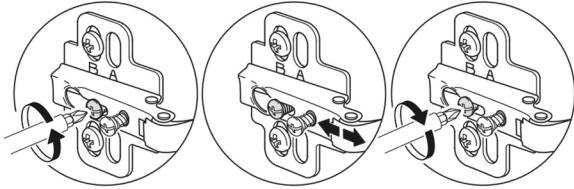
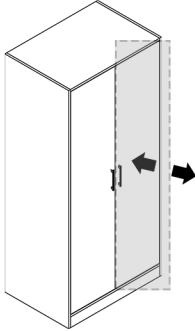

Adjusting screws can change the gap between the door panel and the cabinet side

Cabinet door left and right adjustment

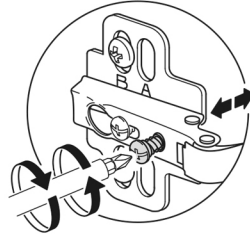
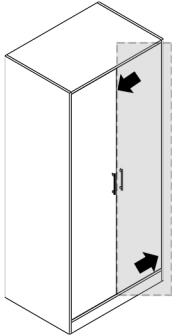

Adjusting screws can change the door panel relative to the cabinet next to the coverage

Cabinet door up and down adjustment

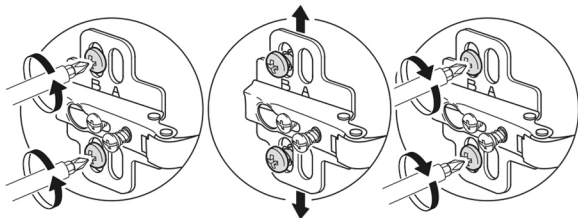
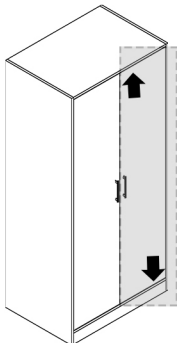

Adjusting screws can correct the upper and lower clearance of the door panel



Hardware installation demonstration

- Before installing the drawer rail, you need to separate the K1 and K2 first.

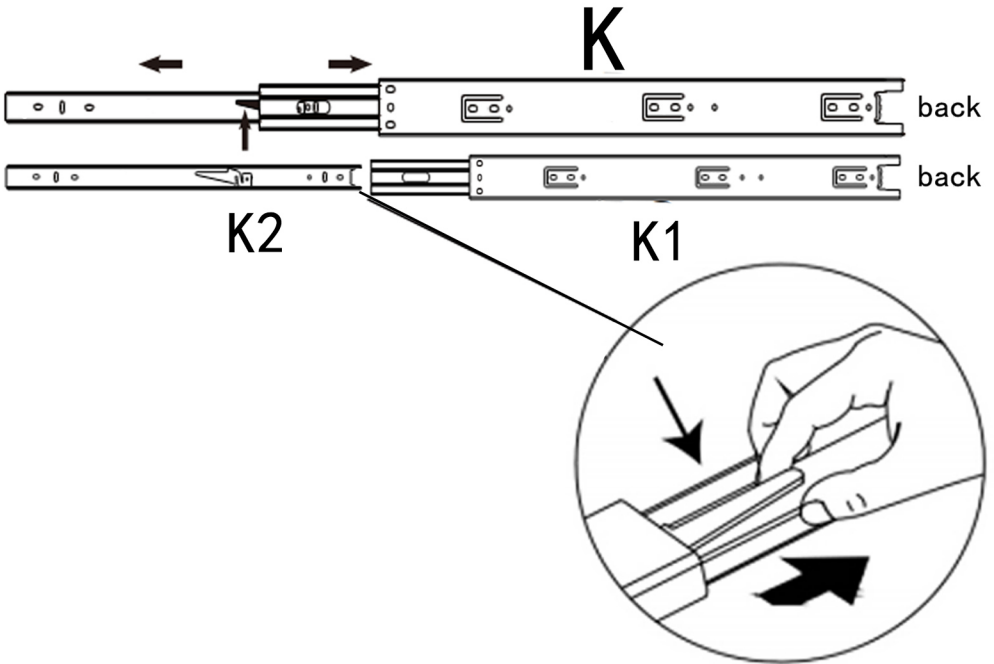

Warm Reminder: Press it and split



Hardware installation demonstration



The first screw hole should corresponded with the board location hole

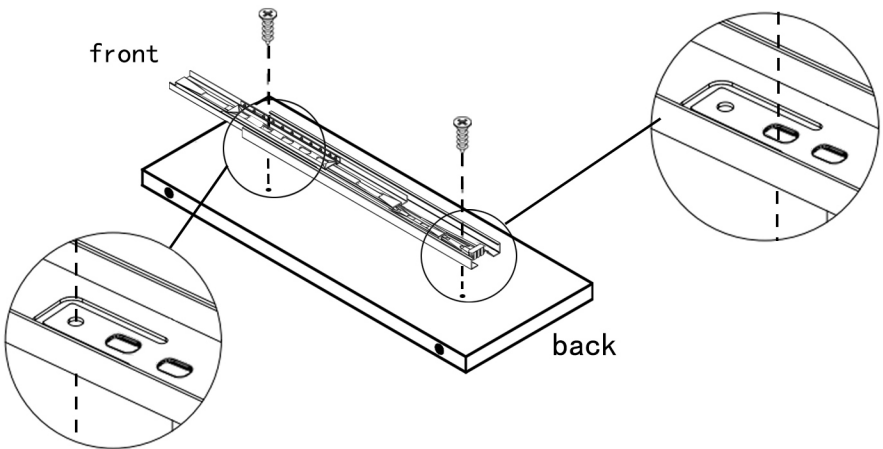

The first screw hole should corresponded with the board location hole

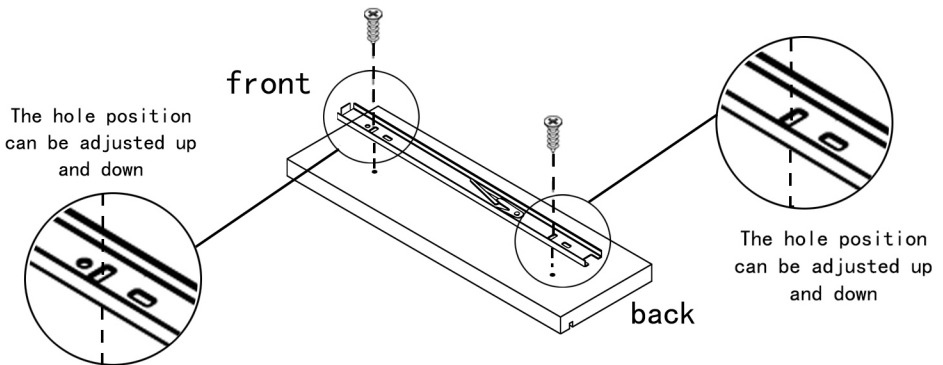

STEP 1

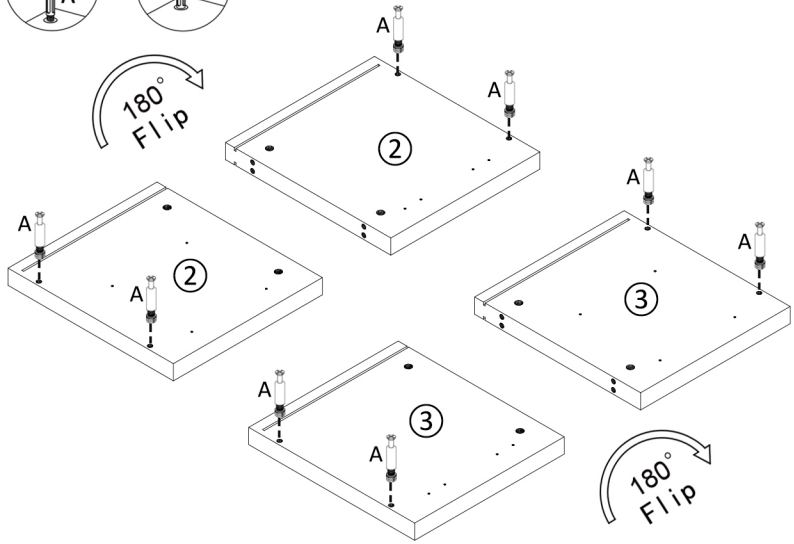
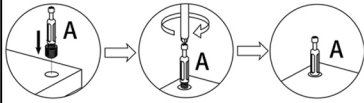

STEP 2

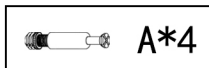
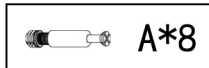
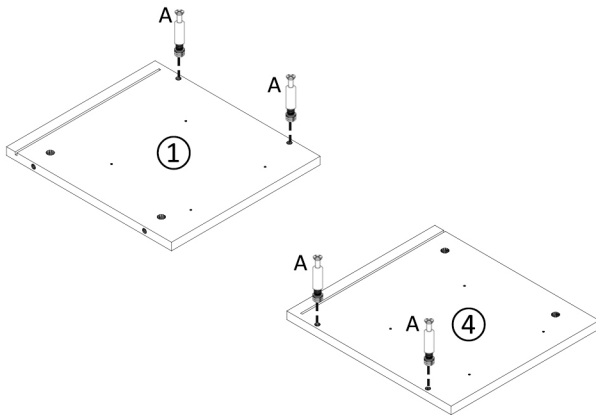
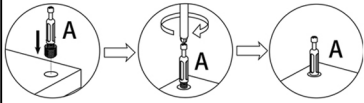

STEP 3

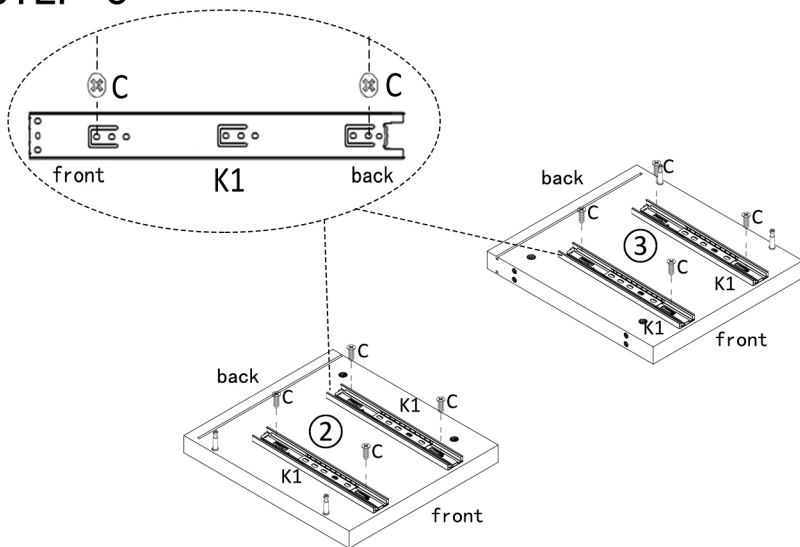

⚠ Please use screws according to the specific size, do not confuse them.

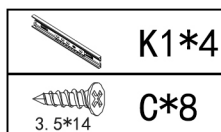

STEP 4

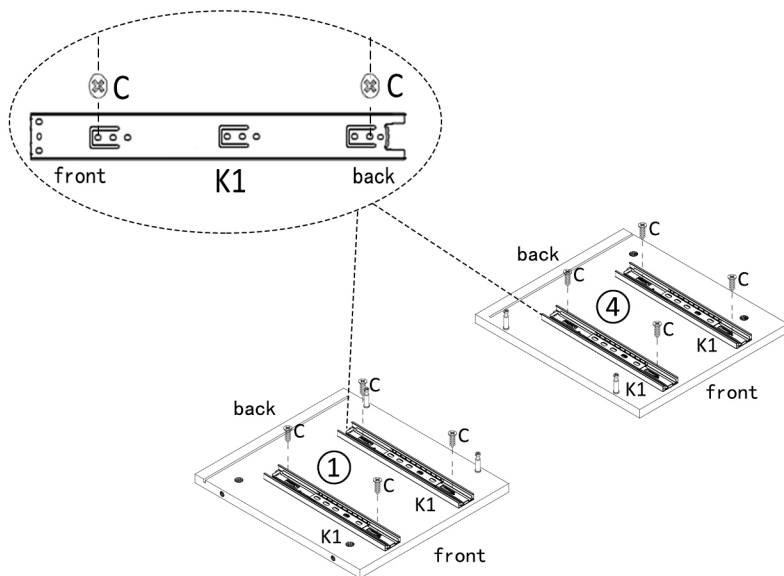

⚠ Please use screws according to the specific size, do not confuse them.

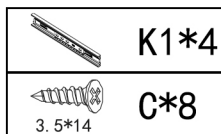

STEP 5

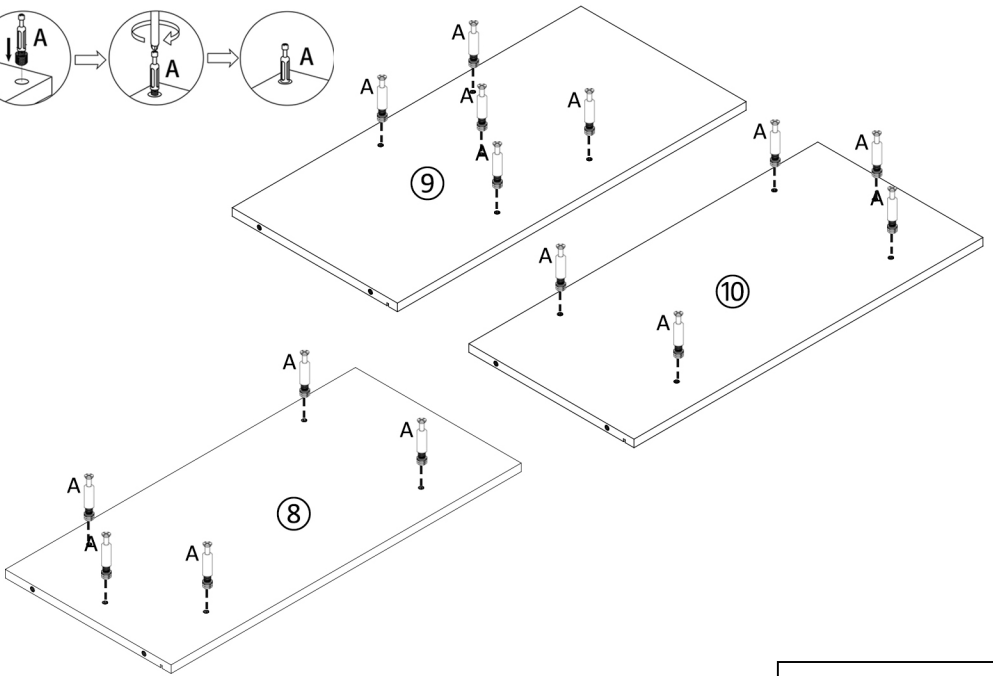
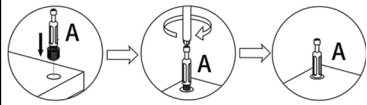

STEP 6

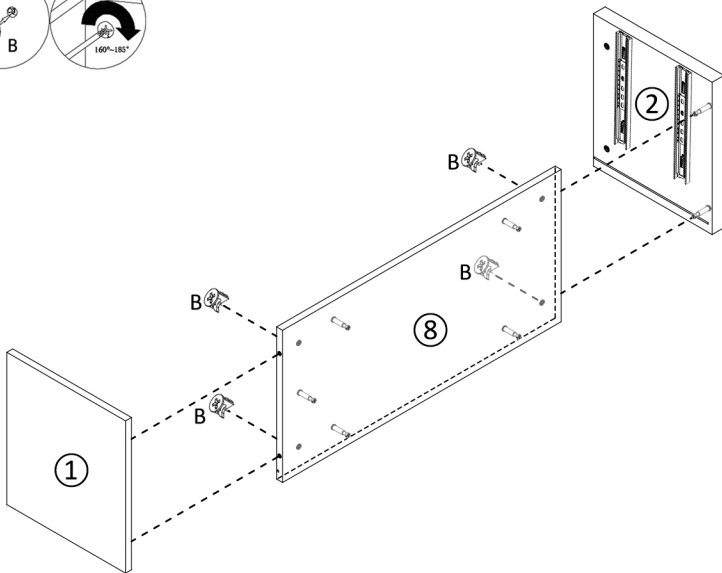
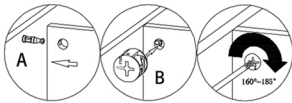

STEP 7

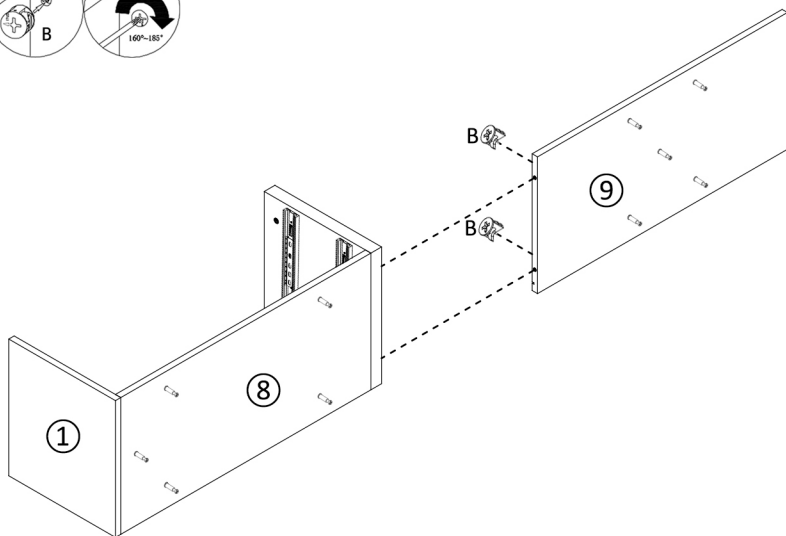
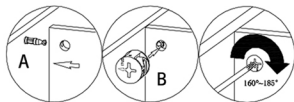

 B*2

STEP 8

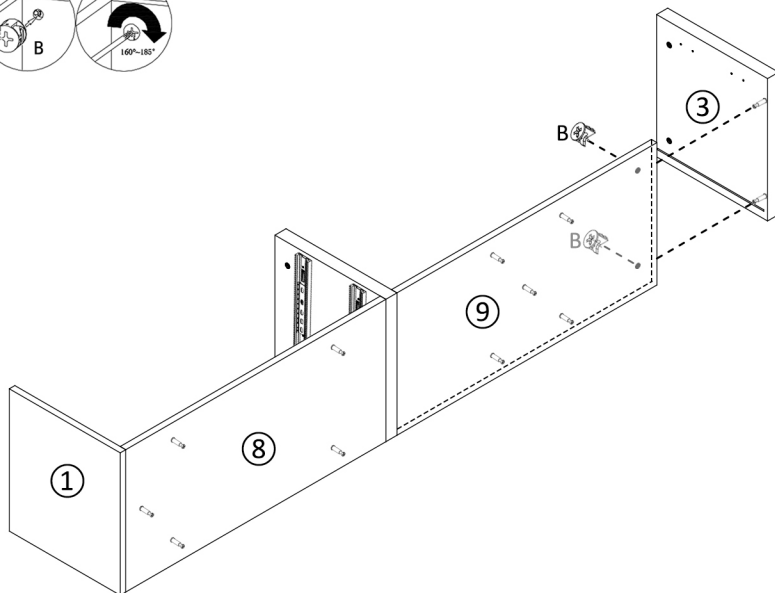
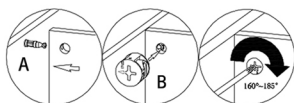

 B*2

STEP 9

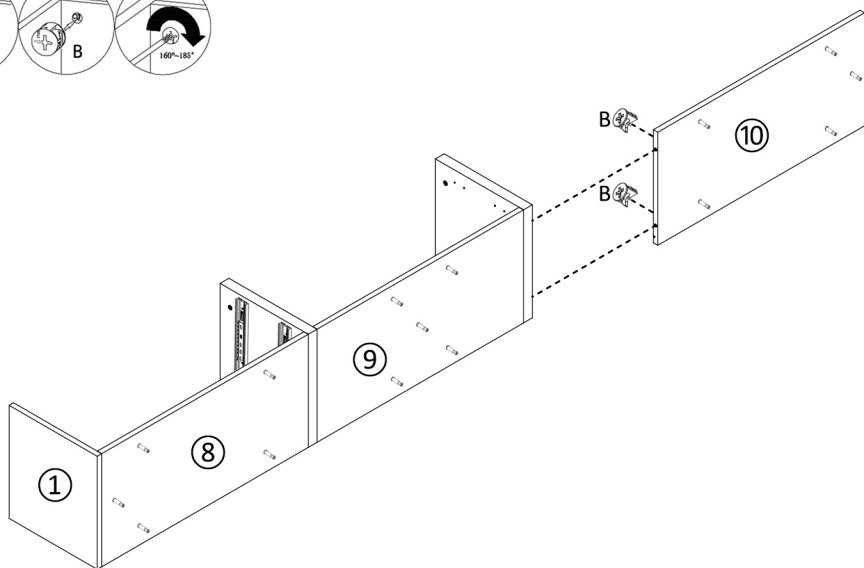
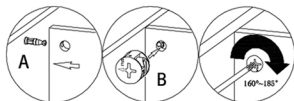

B*2

STEP 10

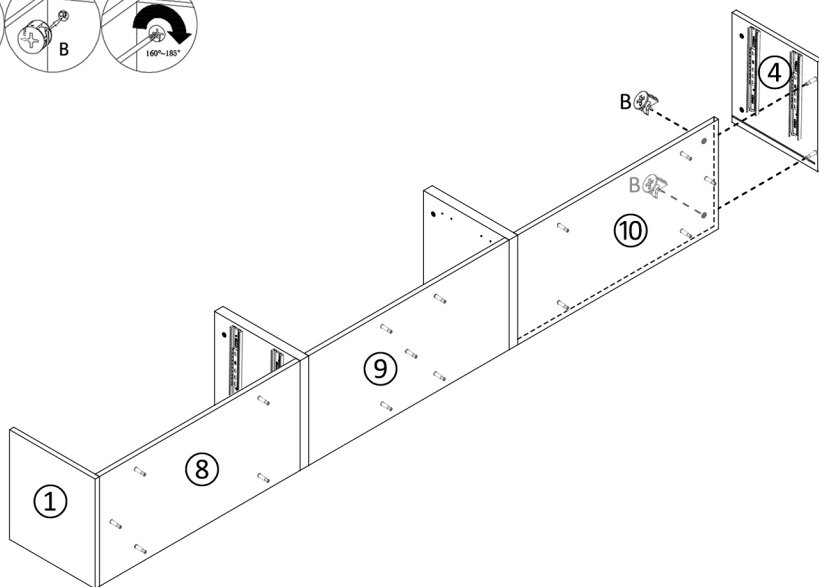
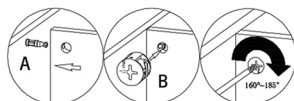

B*2

STEP 11

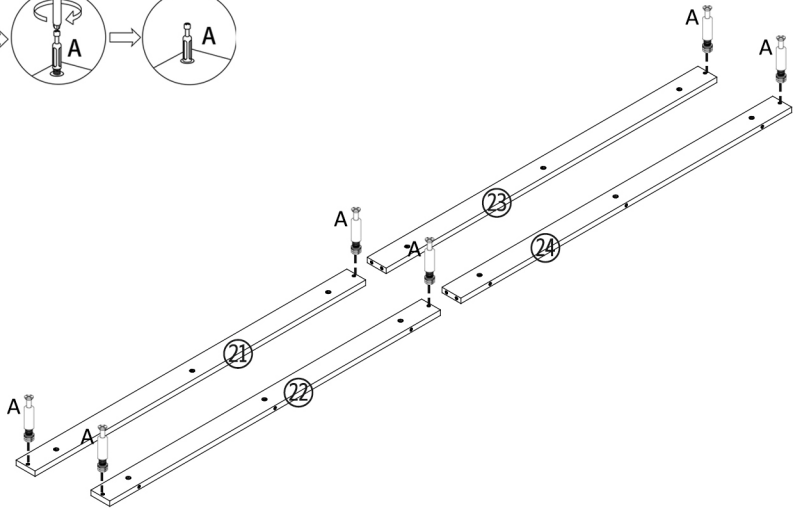
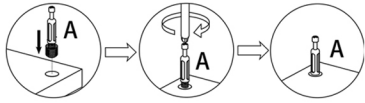

A*6

STEP 12

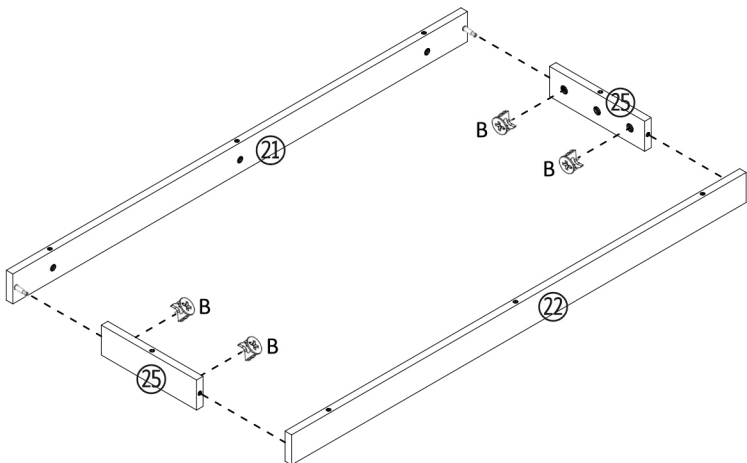
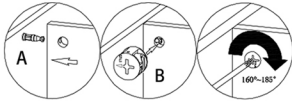

B*4

STEP 13

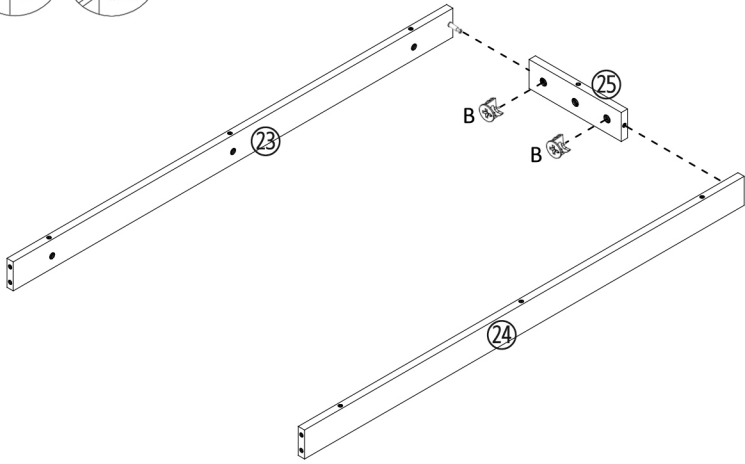
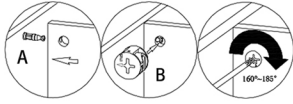

STEP 14

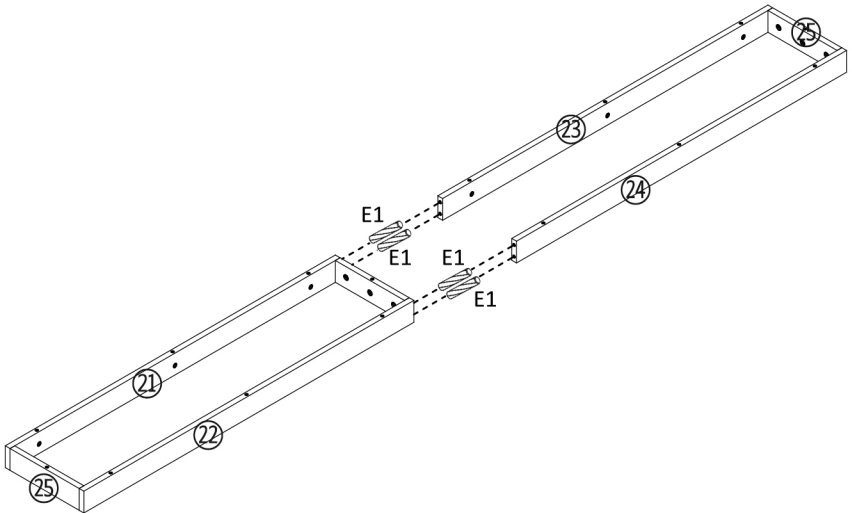

STEP 15

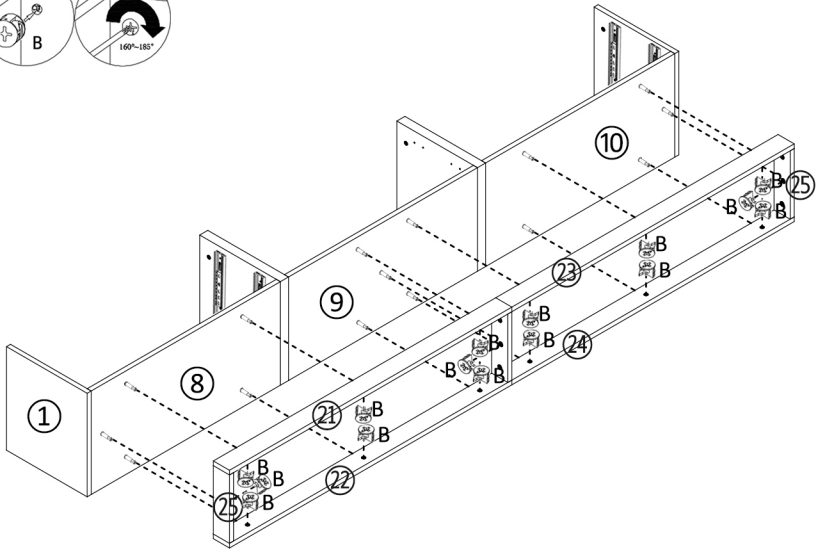
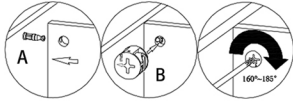

STEP 16

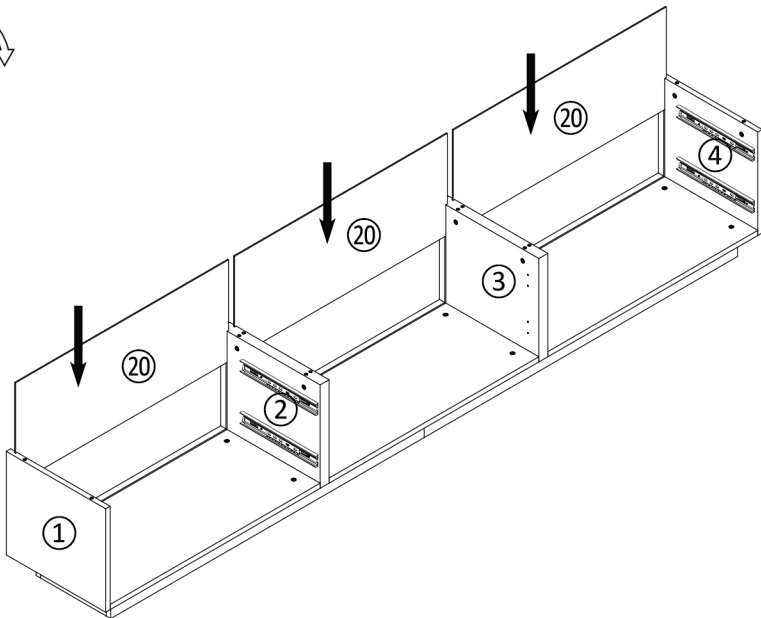
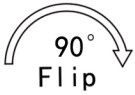

STEP 17

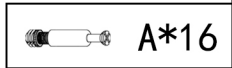
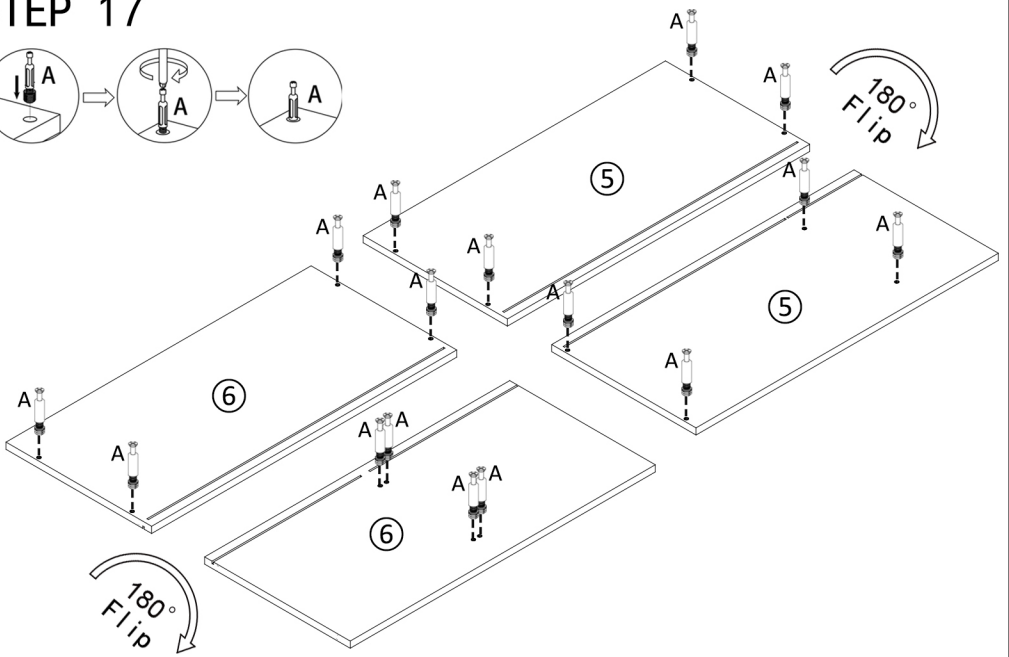
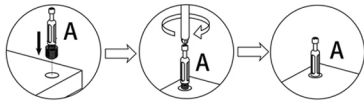

STEP 18

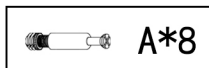
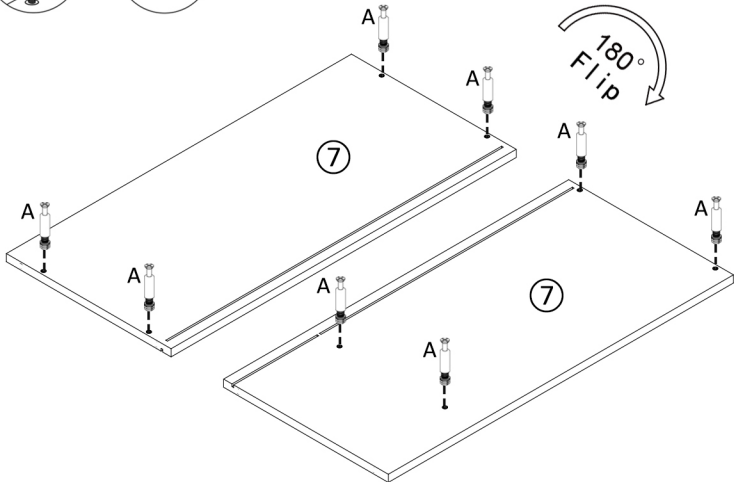
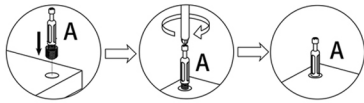

STEP 19

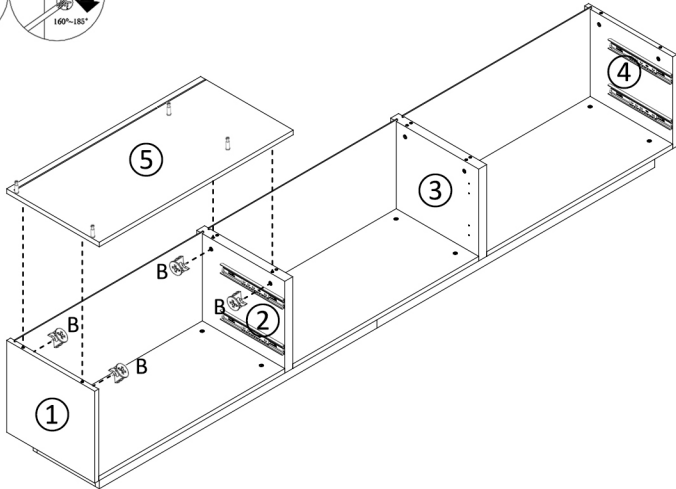
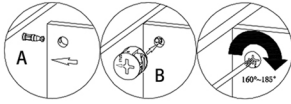

B*4

STEP 20

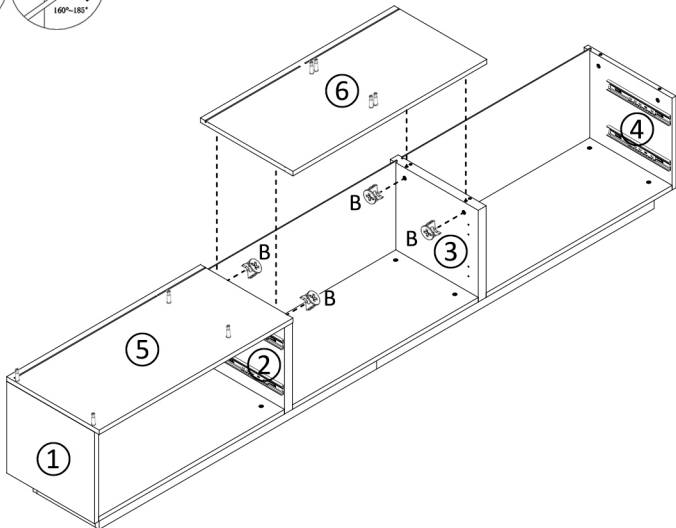
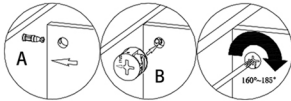

B*4

STEP 21

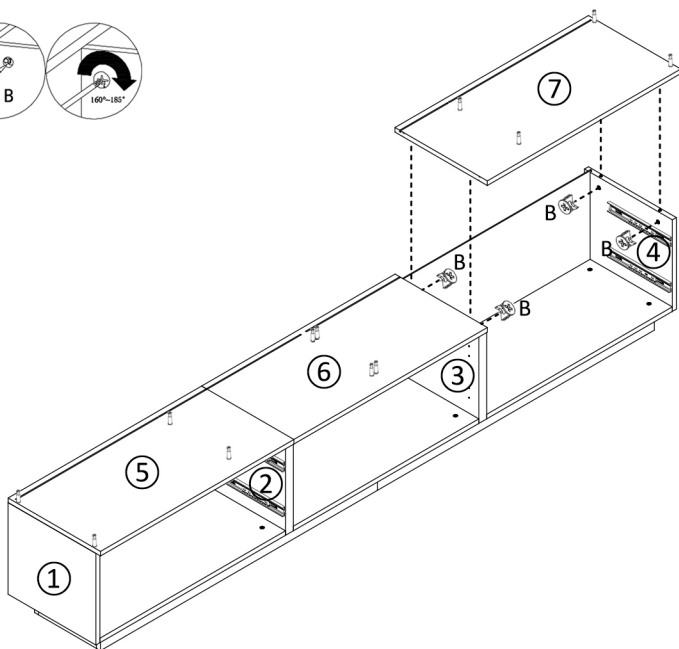
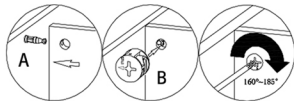

B*4

STEP 22

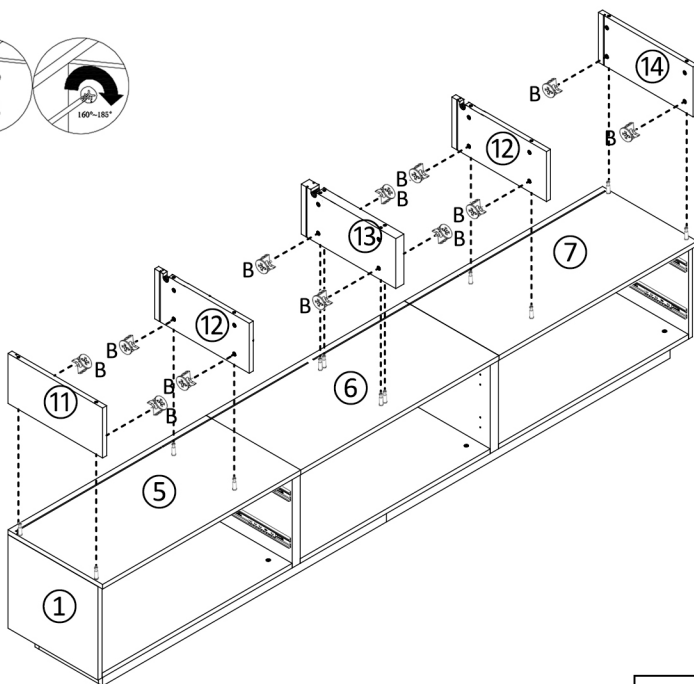
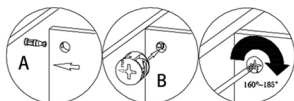

B*12

STEP 23

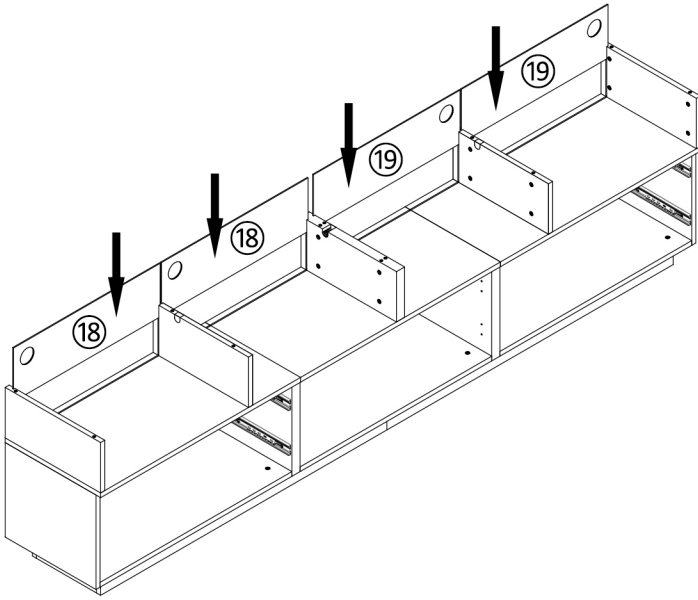

STEP 24

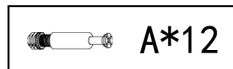
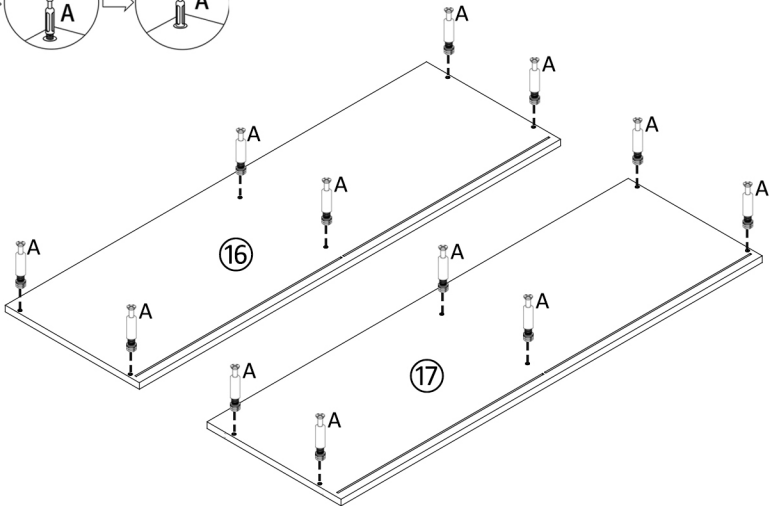
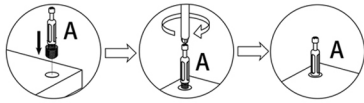

STEP 25

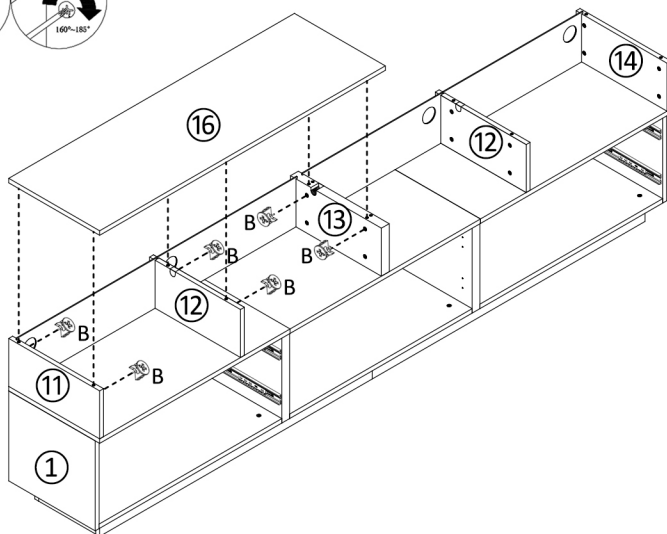
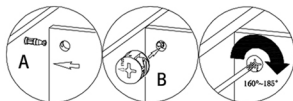

B*6

STEP 26

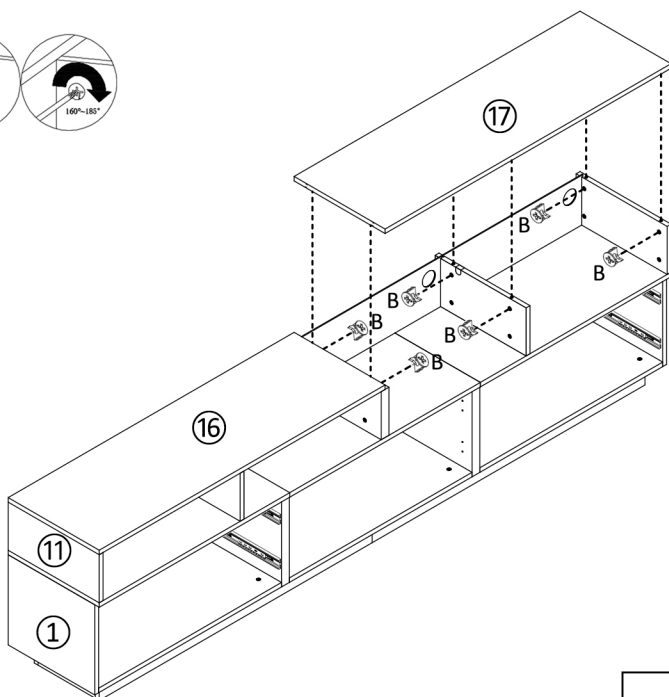
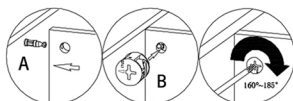

B*6

STEP 27

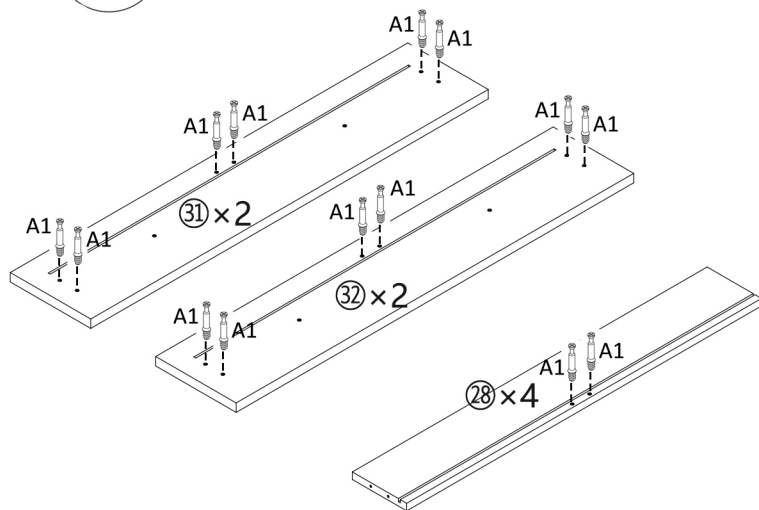
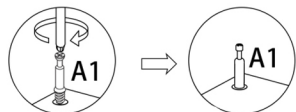

STEP 28

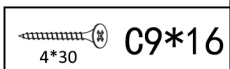
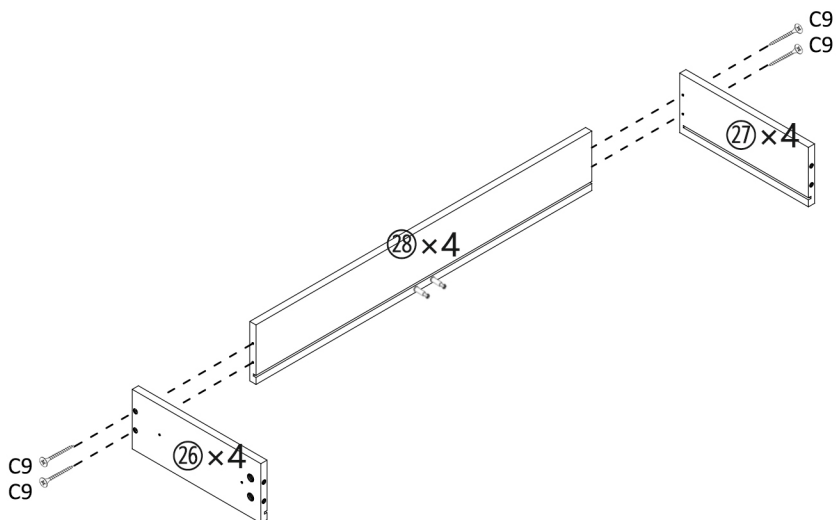

STEP 29

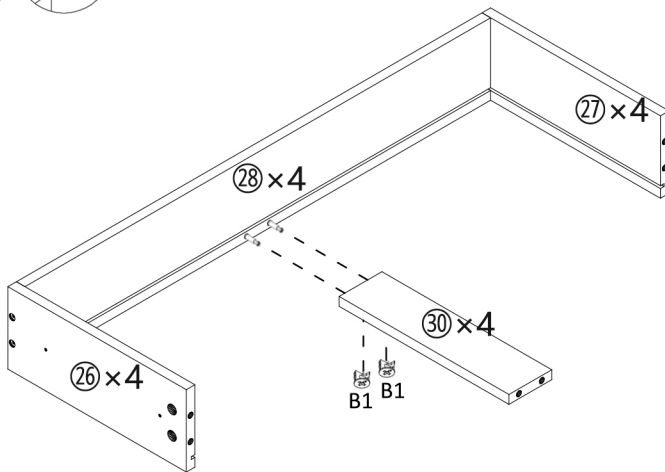
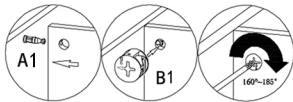

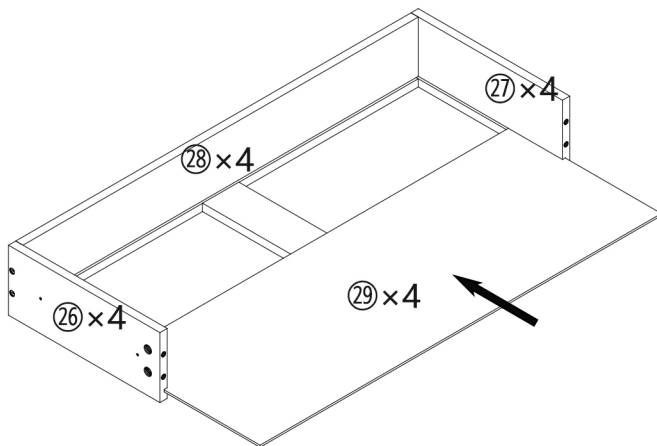

B1*8

STEP 30



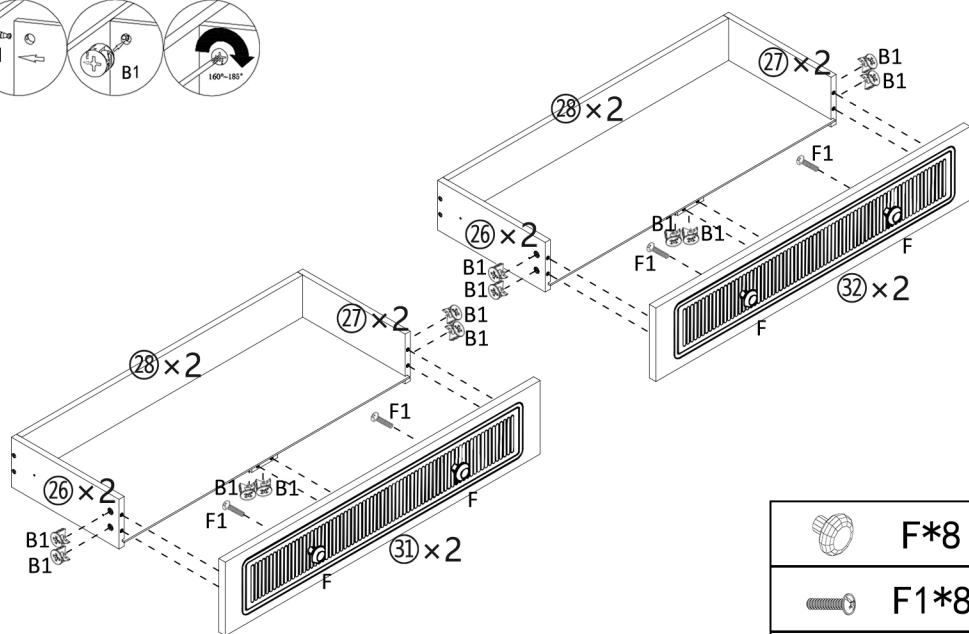
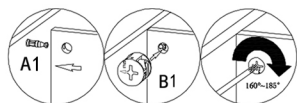

STEP 31

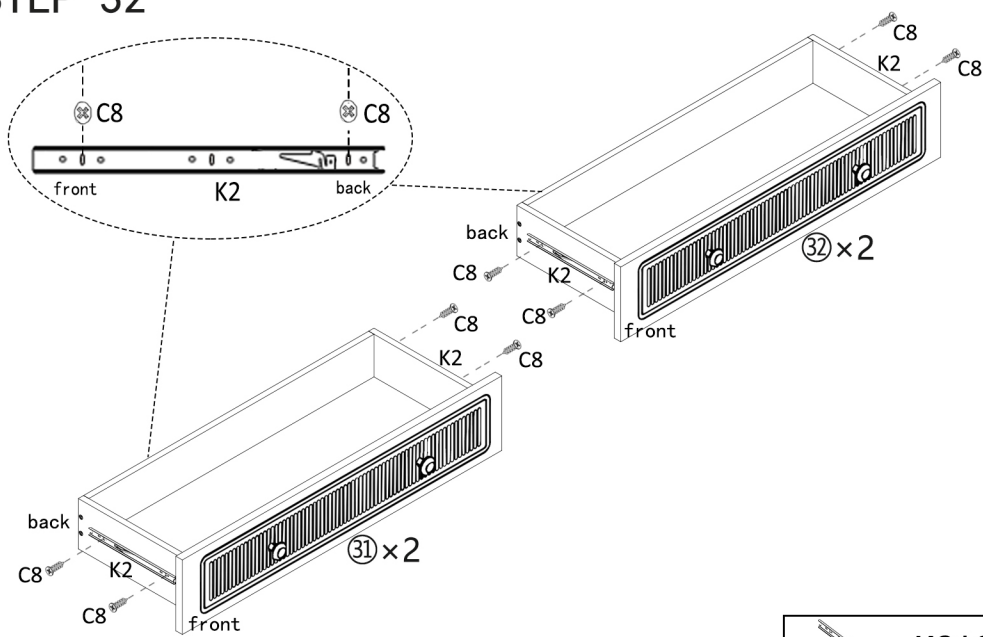
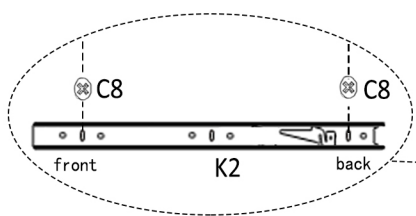

	F*8
	F1*8
	B1*24

STEP 32



	K2*8
	C8*16

⚠ Please use screws according to the specific size, do not confuse them.

STEP 33

Note: When assembling the inner slide rail, it is necessary to place the inner slide rail on the steel ball component first, and push the inner rail parallel to the outer rail together. Direct violence will lead to the falling off or deformation of the rail steel ball.

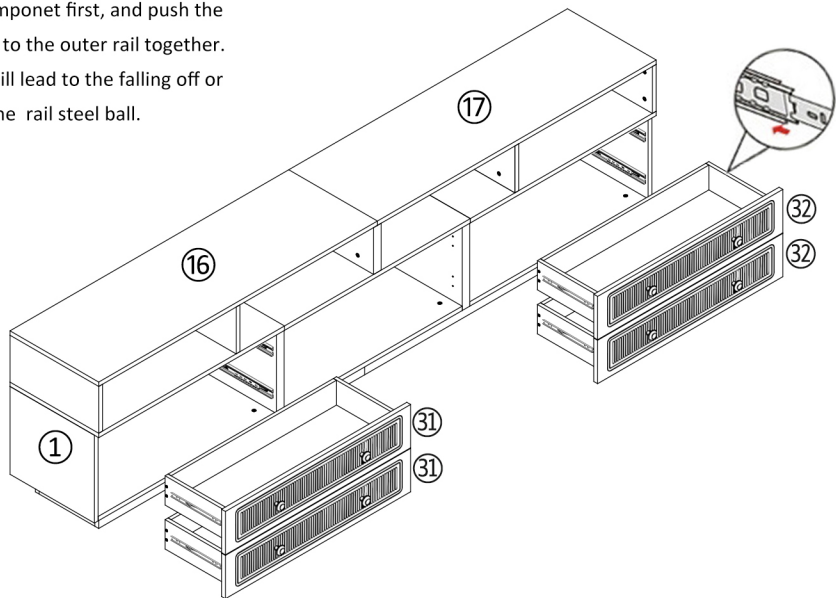

STEP 34

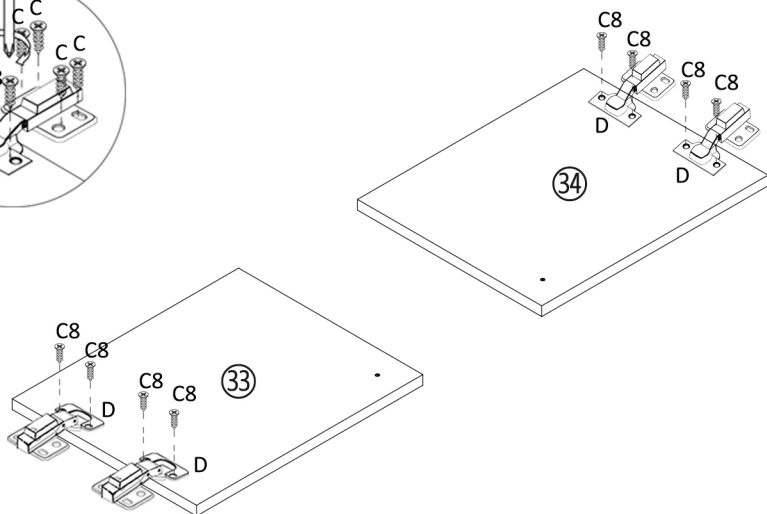
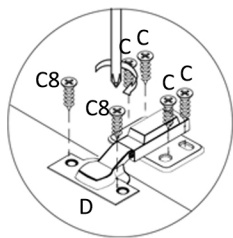

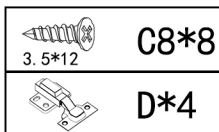

⚠ Please use screws according to the specific size, do not confuse them.

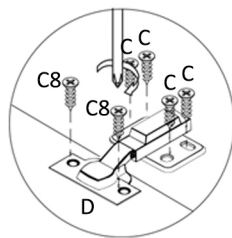
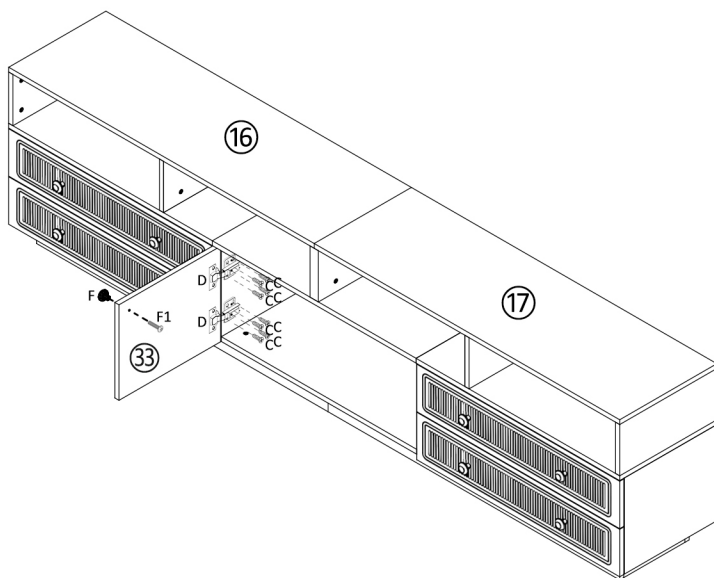

STEP 35





⚠ Please use screws according to the specific size, do not confuse them.

	F*1
	F1*1
 3.5*14	C*8

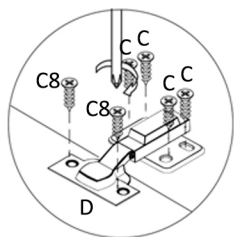
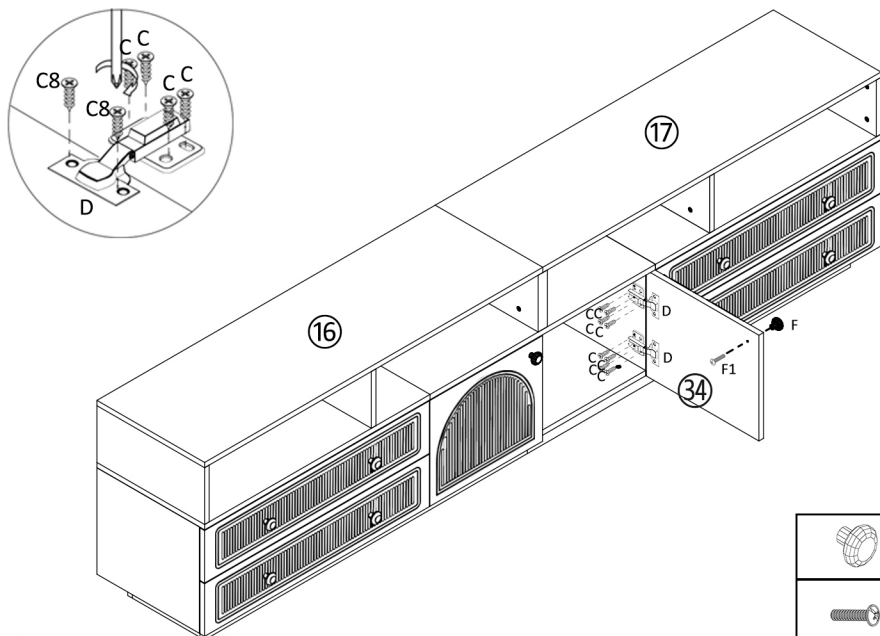
STEP 36



⚠ Please use screws according to the specific size, do not confuse them.

	F*1
	F1*1
 3.5*14	C*8

STEP 37

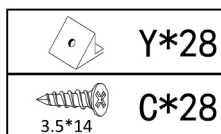
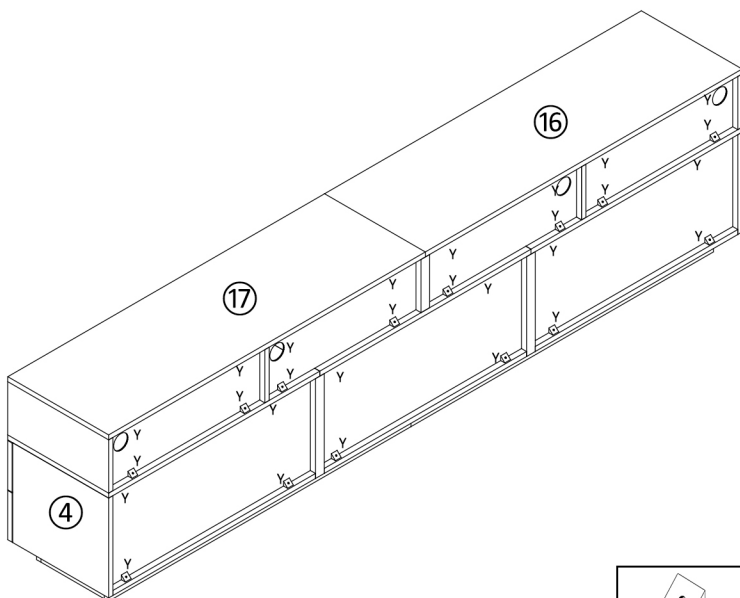
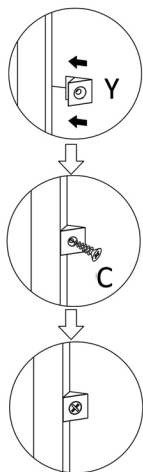

Use tools to install if necessary

STEP 38

1. Please thread the LED light strip through the wire passing holes on board No. 12 and board No. 13.

2. Stick the light strip.

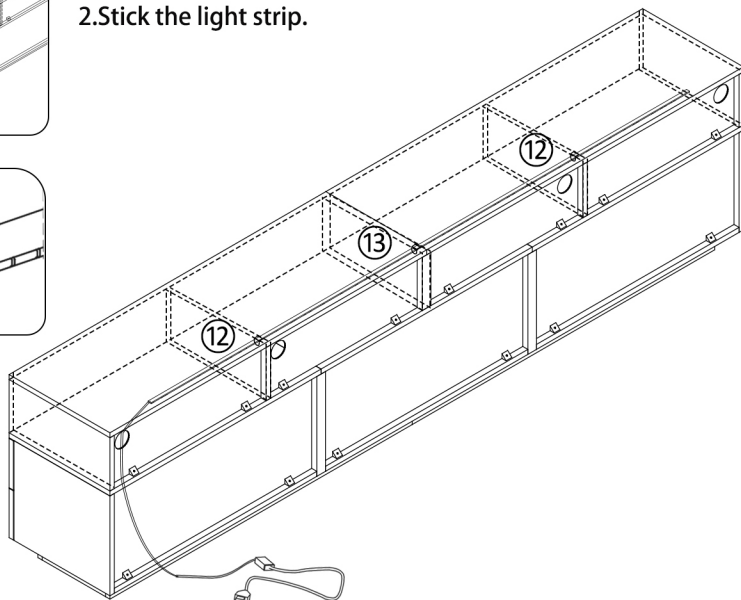
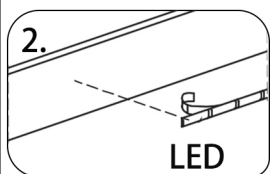
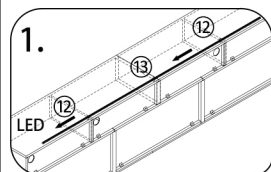

STEP 39

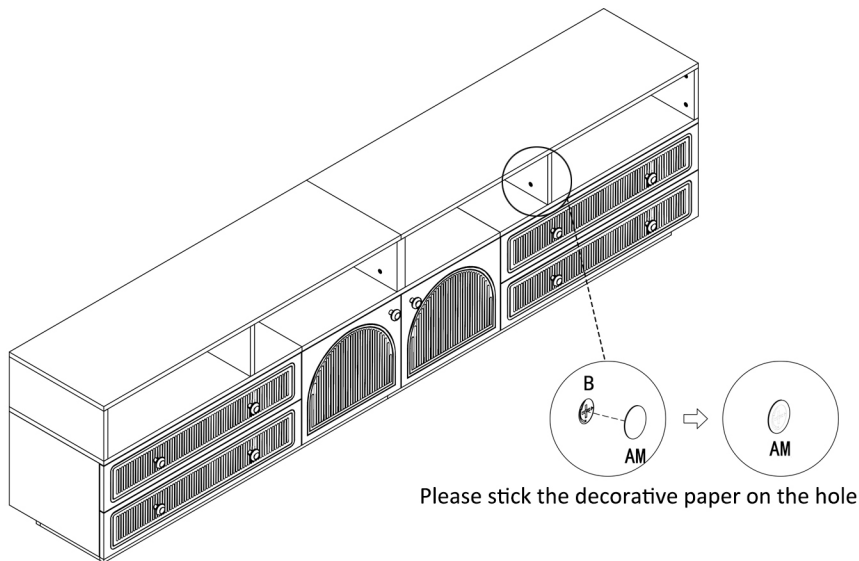

Please stick the decorative paper on the hole