

3 Tier Butcher Block Kitchen Cart with Drawers

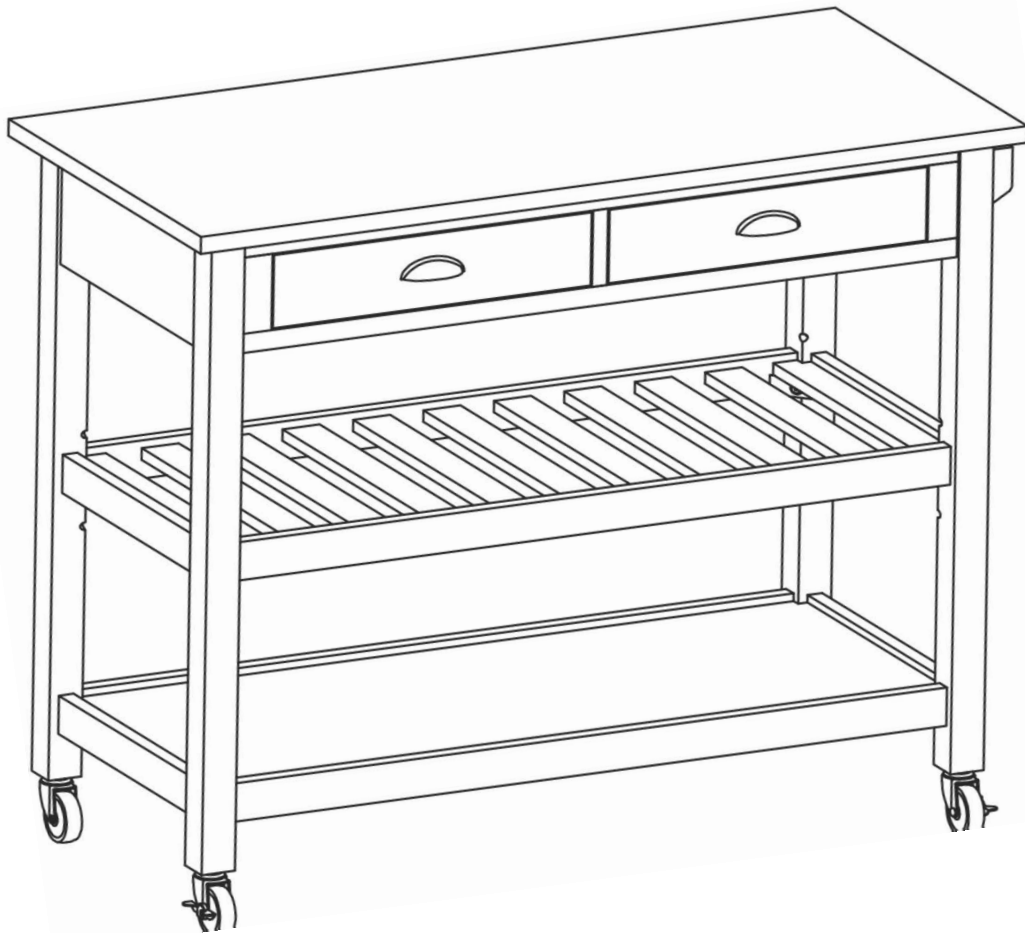

ASSEMBLY INSTRUCTIONS

We have designed our furniture with you , the customer in mind . Our clear , easy to follow , step by step instructions will guide you through the project from start to finish . Feel confident that this will be a fun and rewarding project . The final product will be a quality piece of furniture that will go together smoothly and give years of enjoyment .

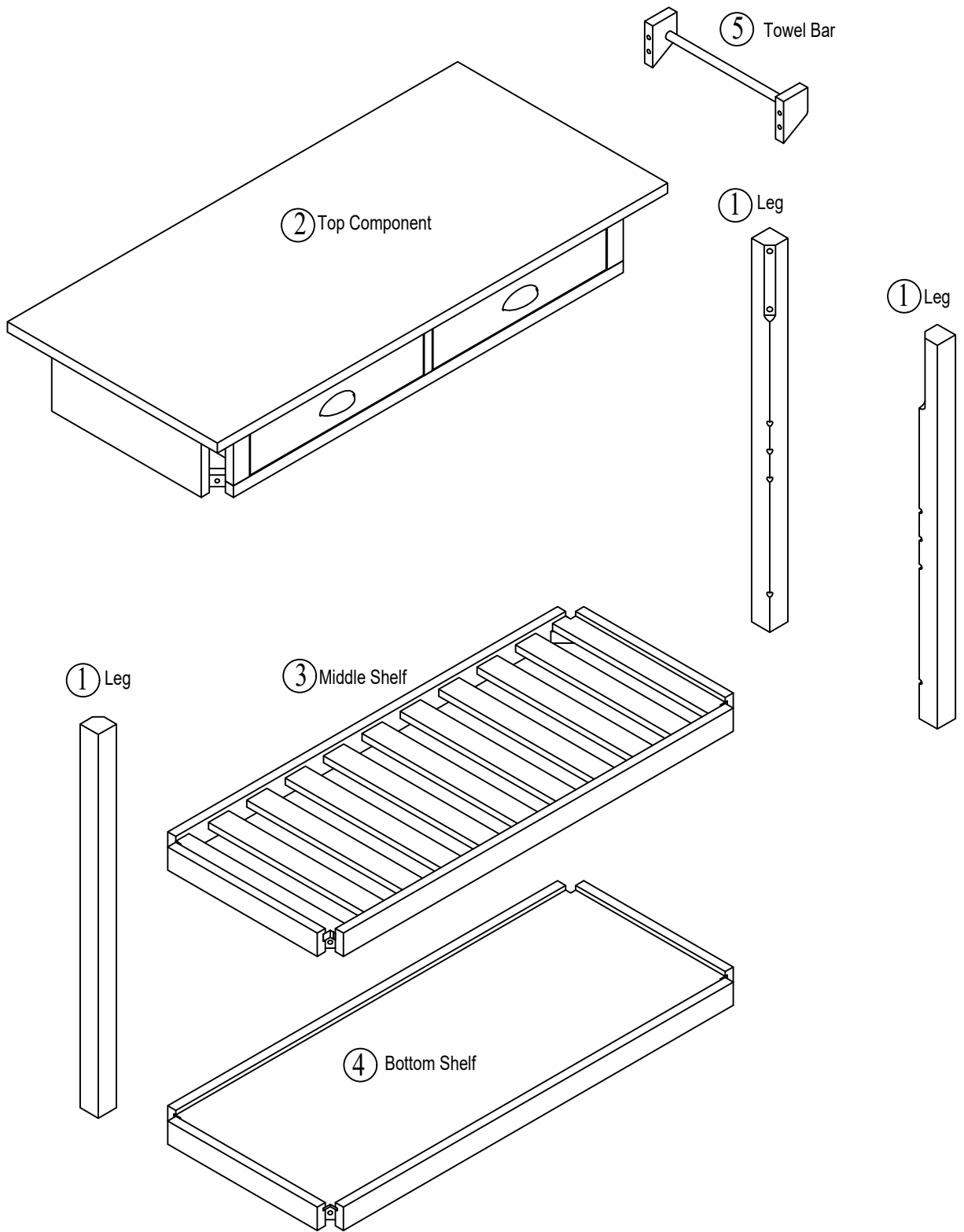

A. 8 pcs
Plug

B. 2 pcs
Wheel

C. 2 pcs
Locking
Wheel

D. 20 pcs
Washer

E. 4 pcs
Short
Bolt

F. 8 pcs
Medium
Bolt

G. 8 pcs
Long
Bolt

H. 1 pc
Allen
Wrench

I. 1 pc
Wrench

STEP 1

HARDWARE
NEEDED

D x 4
E x 4
H x 1

- 1.) Carefully Flip over Top Component (2) and pull out both Drawers.
- 2.) Align Towel Bar (5) with the holes on the side of the Top Component (2).
- 3.) Attach Towel Bar (5) with Short Bolts (E) and Washers (D) as shown, start by hand tightening the bolts and fully tighten with the Allen Wrench (H).

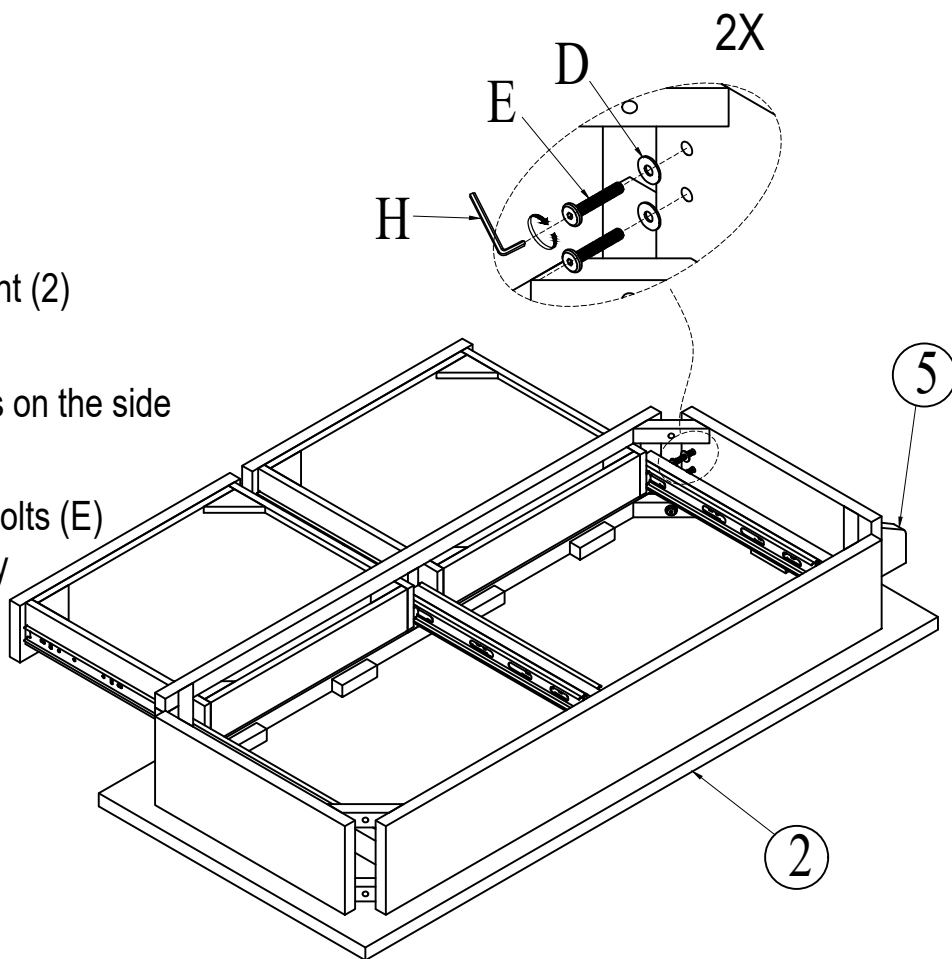

STEP 2

HARDWARE
NEEDED

D x 8
G x 8
H x 1

- 1.) Align Legs (1) with Top Component (2) as shown.
- 2.) Attach Legs (1) with the Long Bolts (G) and Washers (D) as shown, start by hand tightening the bolts and fully tighten with the Allen Wrench (H).

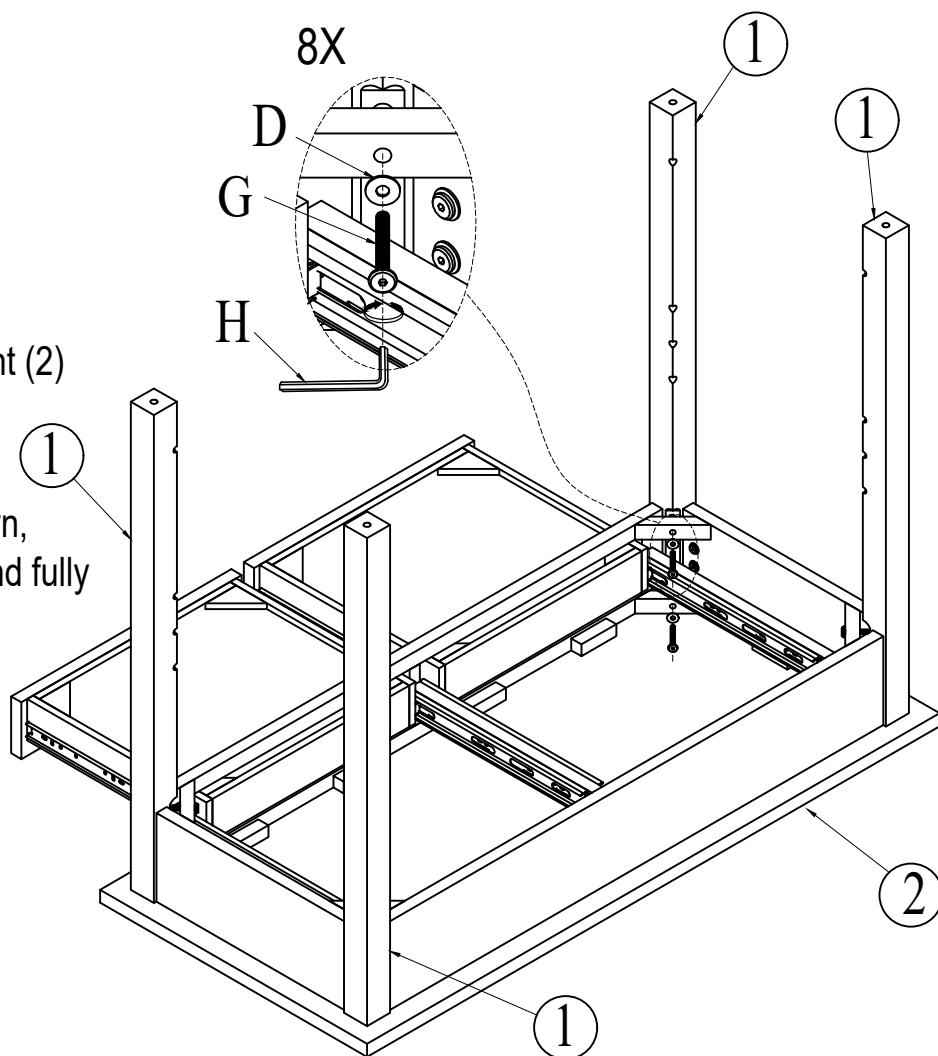

*Hold Shelves steady while attaching the Bolts *

STEP 3

HARDWARE
NEEDED

D x 4
F x 4
H x 1

- 1.) Position Middle Shelf (3) at desired height on the Legs (1).
- 2.) Attach the Middle Shelf (3) to Legs (1) with the Medium Bolts (F) and Washers (D) as shown, start by hand tightening the bolts and fully tighten with the Allen Wrench (H).

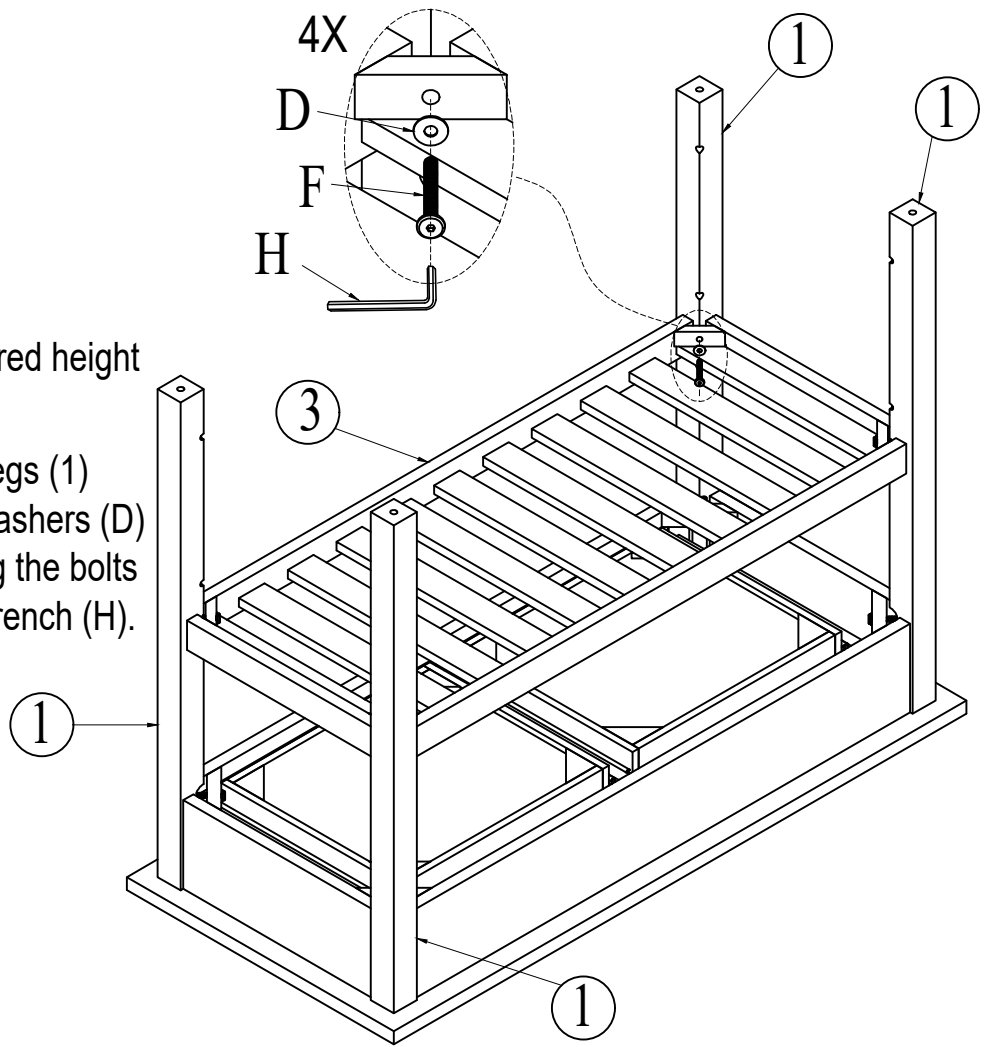

STEP 4

HARDWARE
NEEDED

D x 4
F x 4
H x 1

- 1.) Align the Bottom Shelf (4) with the Legs (1) as shown.
- 2.) Attach the Bottom Shelf (4) with the Medium Bolts (F) and Washers (D) as shown, start by hand tightening the bolts and fully tighten with the Allen Wrench (H).

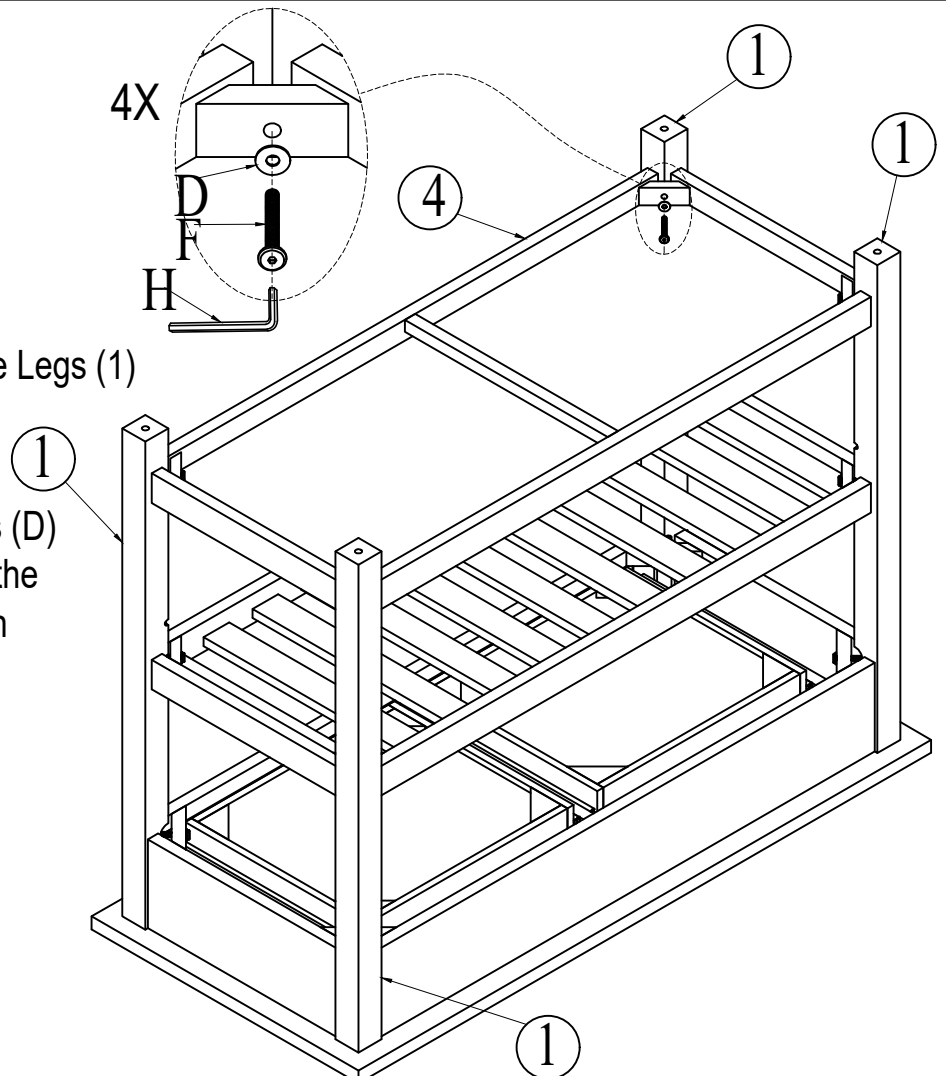

STEP 5

1.) Attach Locking Wheels (C) to the front of the unit with the Wrench (I) as shown.

2.) Attach Wheels (B) to the back of the unit with the Wrench (I) as shown.

HARDWARE
NEEDED

B x 2

C x 2

I x 1

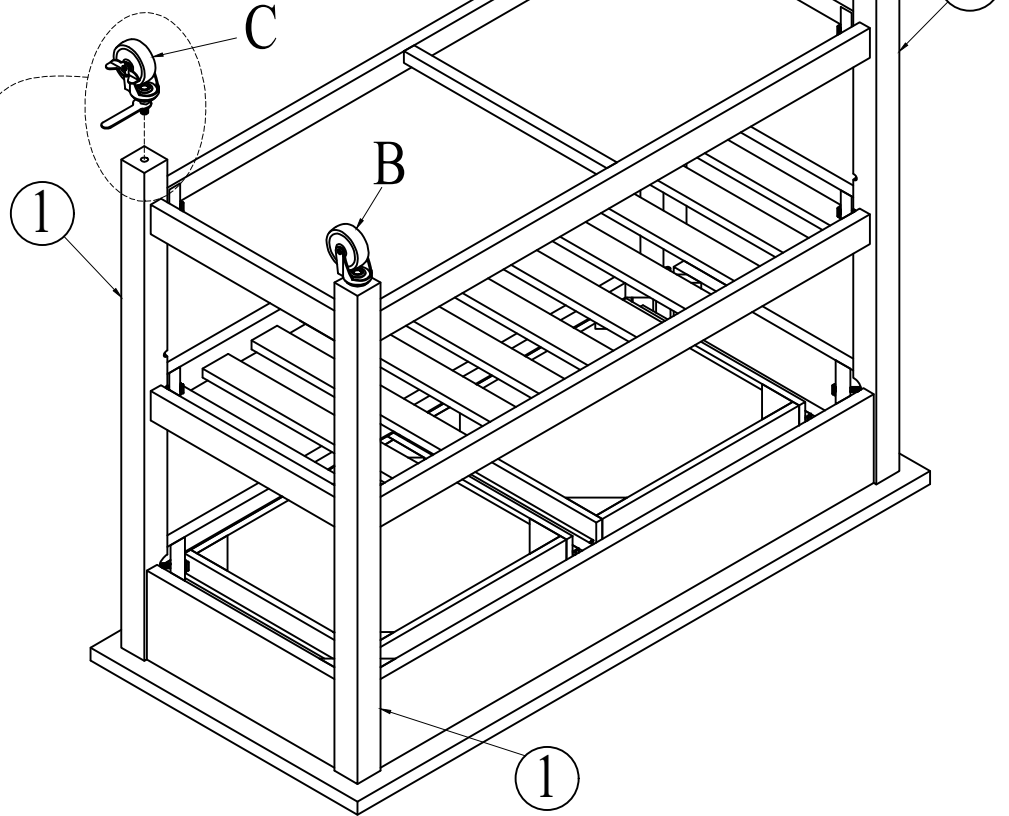
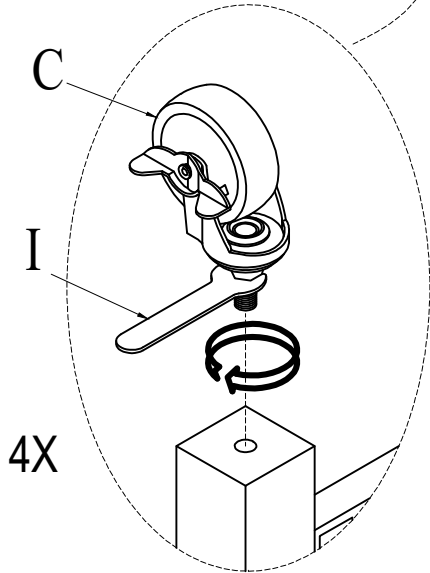

STEP 6

HARDWARE
NEEDED

A x 8

- 1.) Carefully Turn over the unit.
- 2.) Insert Plugs (A) into unused Middle Shelf leg holes as shown.
- 3.) Enjoy your new quality Piece of furniture for years to come

