

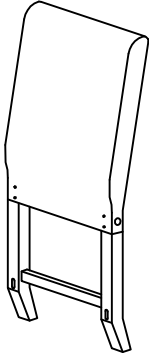

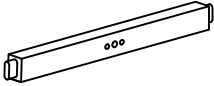
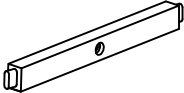
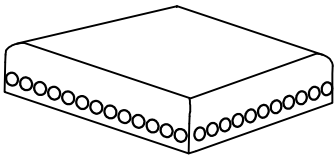
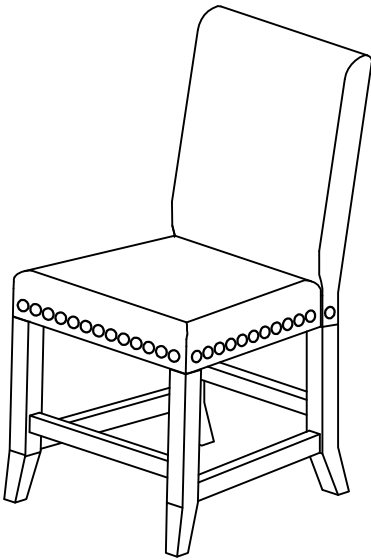
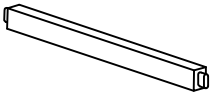
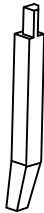
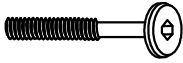
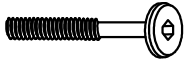

ASSEMBLY INSTRUCTIONS

<p>A. BACK FRAME 1 PC</p> 	<p>F. LEFT STRETCHER 1 PC</p> 	<p>G. RIGHT STRETCHER 1 PC</p> 
<p>B. SEAT FRAME 1 PC</p> 	<p>ASSEMBLED</p> 	
<p>C. FRONT STRETCHER 1 PC</p> 		
<p>D. LEFT LEG 1 PC</p> 		

HARDWARE ENCLOSED IN BOX

1	ALLEN BOLT M6 x 50 MM	04 PCS	2	ALLEN BOLT M6 x 70 MM	04 PCS	3	SPRING WASHER M9/11	08 PCS	4	WASHER M9/22	08 PCS	5	SCREW M4 x 40 MM	06 PCS
														
6	ALLEN KEY N4	01 PC												
														

TOOL REQUIRED

PHILLIPS HEAD SCREW
DRIVER NOT PROVIDED

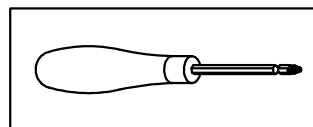

STEP 1:

Attach seat frame (B) to back frame (A) with bolts (2), spring washers (3) and flat washers (4).

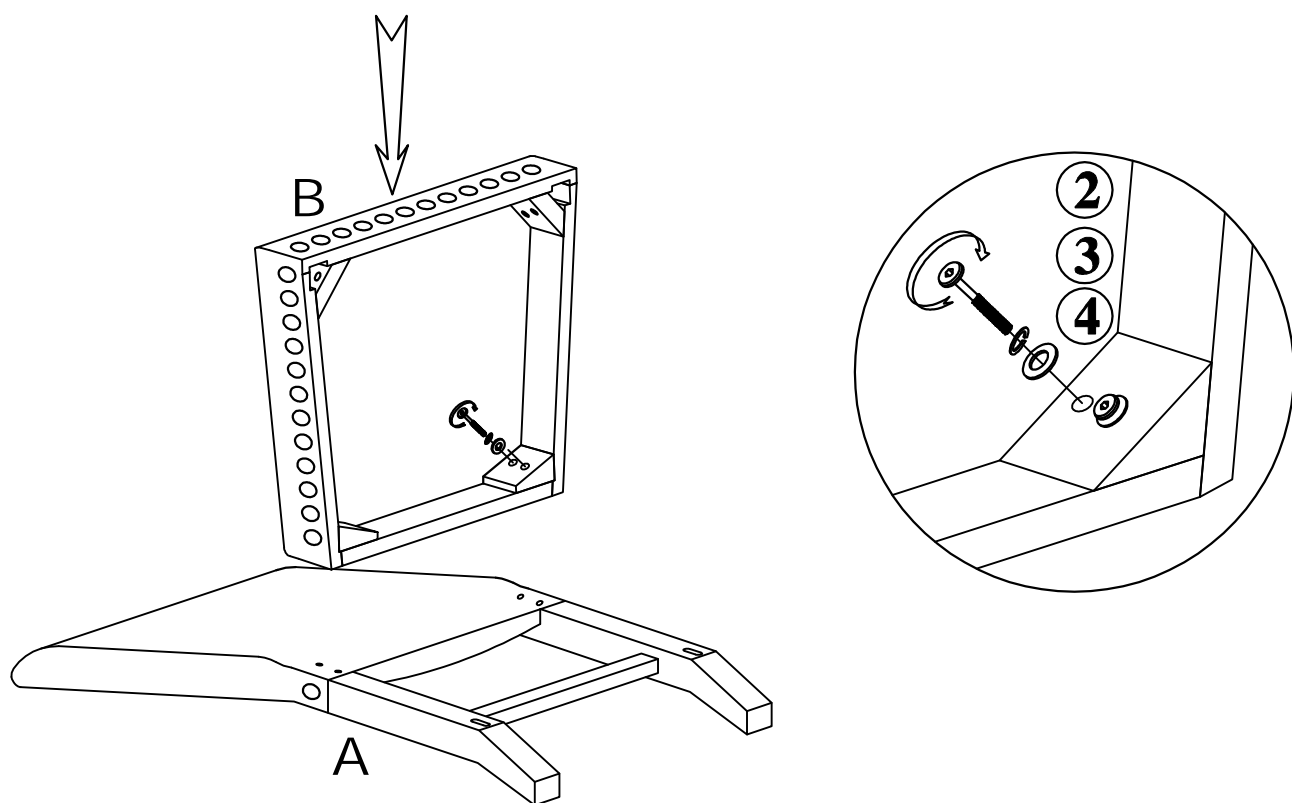

STEP 2:

Attach the stretchers (F)&(G) to the back frame (A).

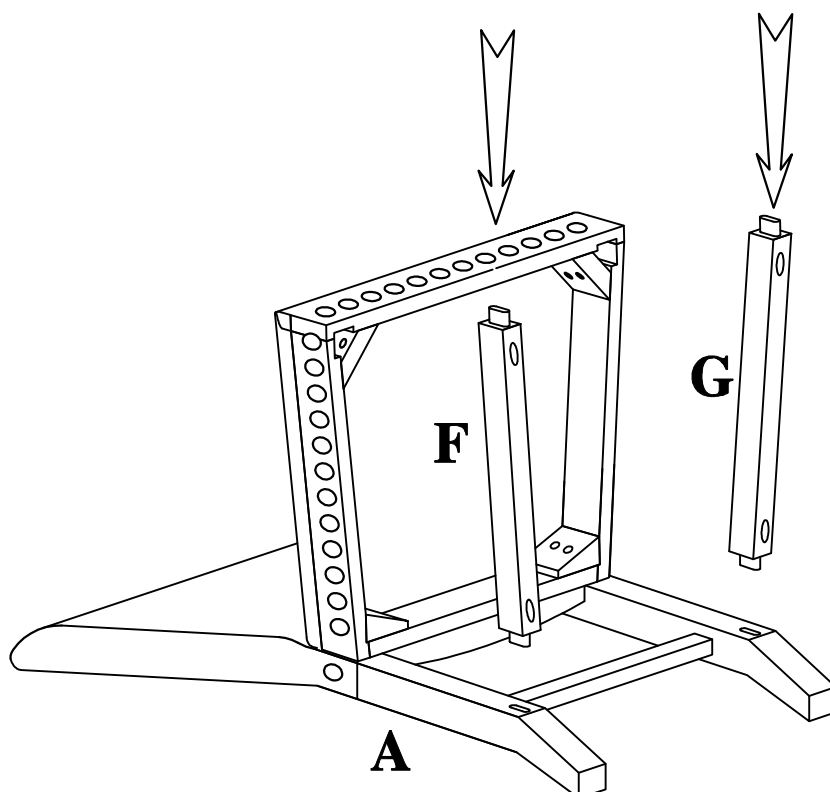

STEP 3:

Insert the left leg (D) and connect with bolt (1), spring washer (3), flat washer (4).

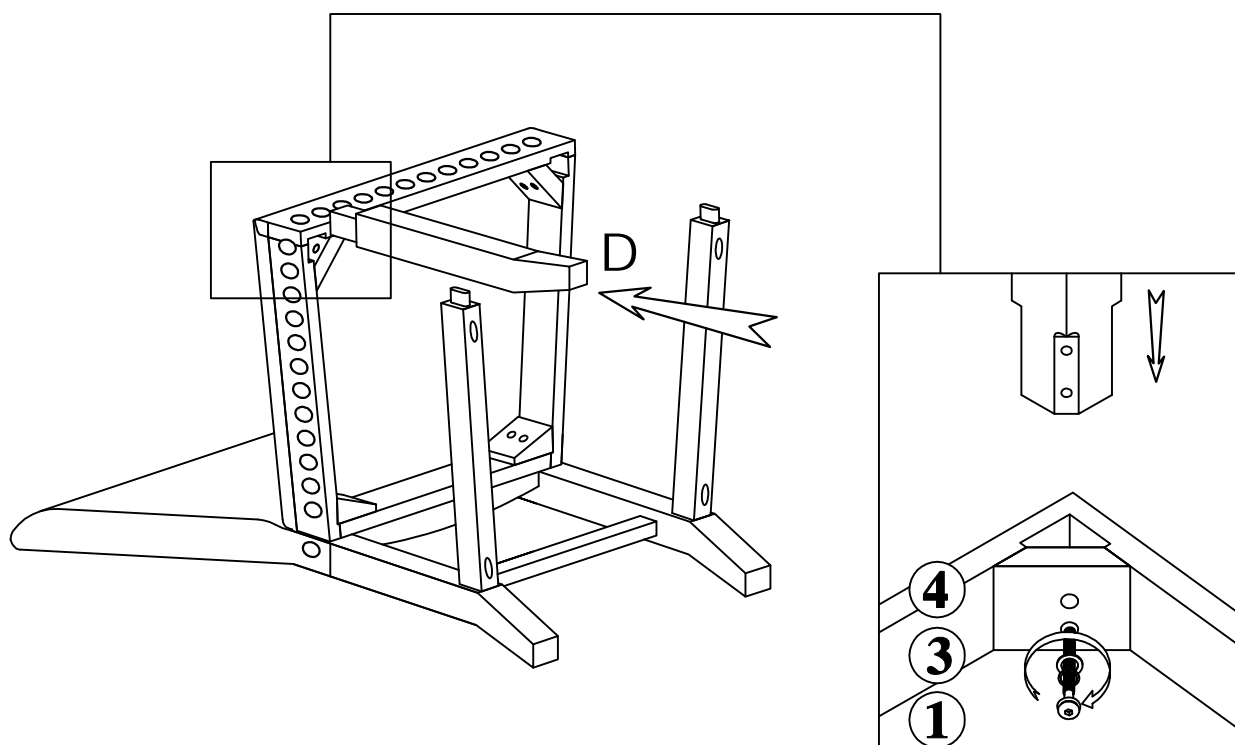

STEP 4:

Connect front stretcher (C) to left leg.

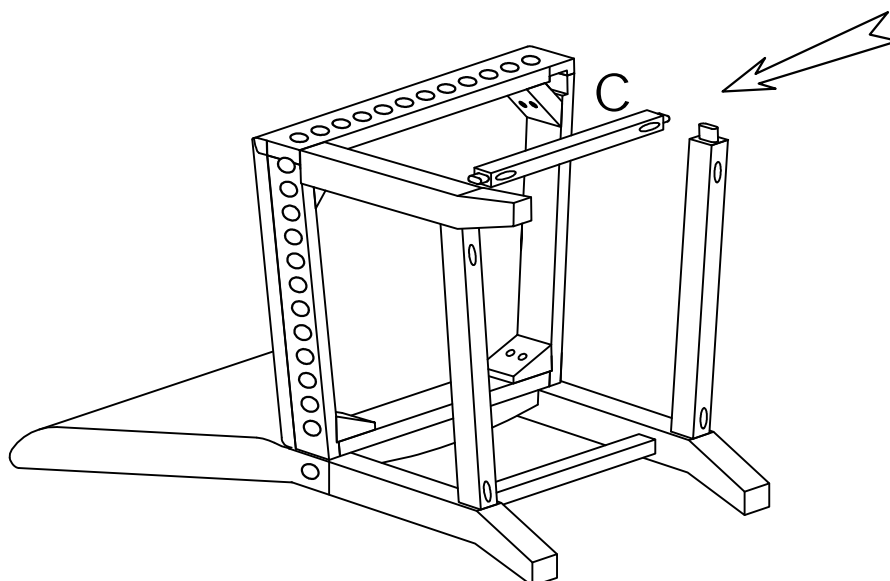

STEP 5:

Insert the right leg (E) and connect with bolt (1), spring washer (3), flat washer (4).

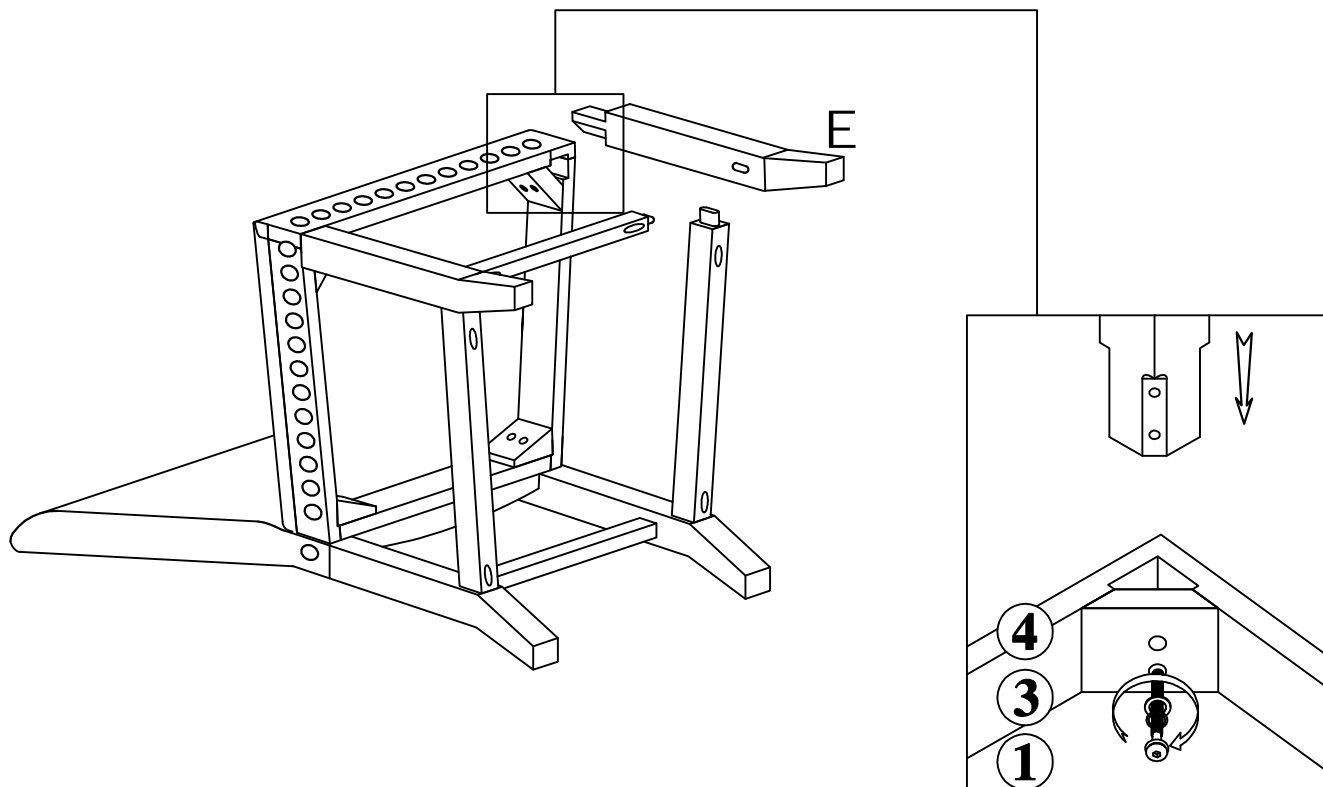

STEP 6:

Connect the stretchers with screws (5).
Assembly complete.

