



Triangle Bench

Installation Guide

phillips
collection

every piece a conversation

Triangle Bench

Installation Guide

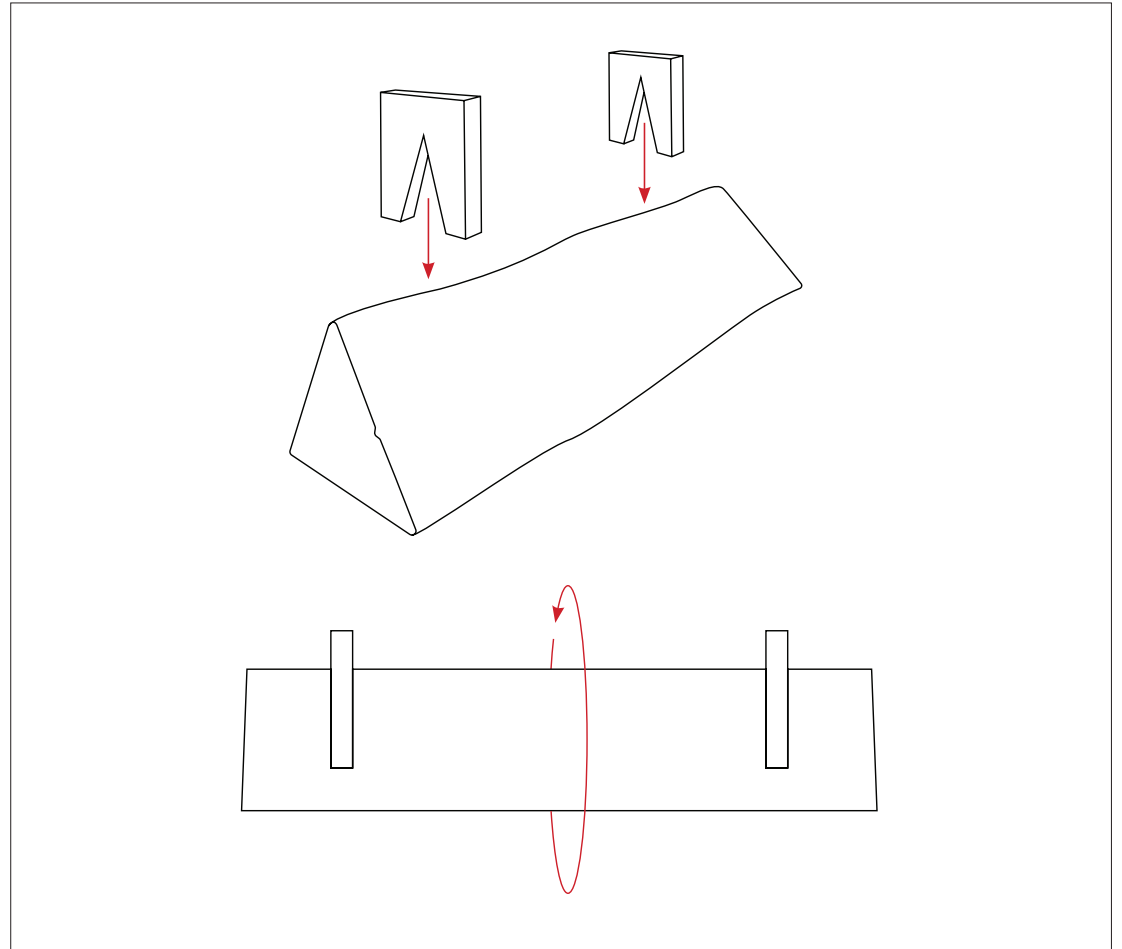
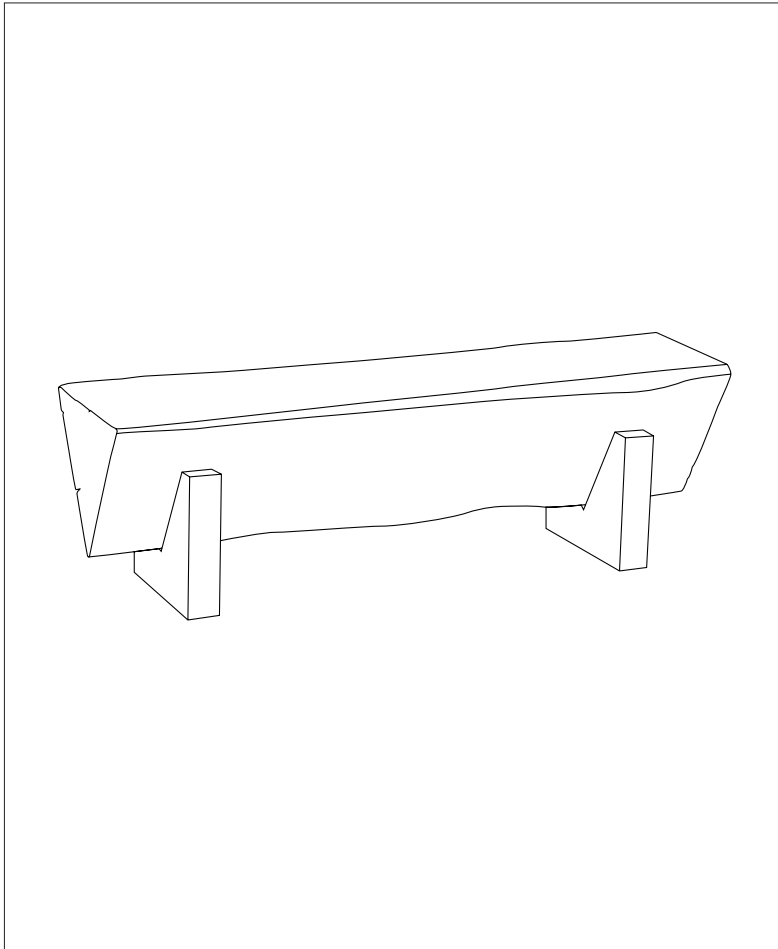

1. Place the Triangle Bench upside down on a clean, soft surface to avoid scratching.
2. Locate the matching labels on the bench and each leg. Rest the legs in their labeled positions—no tools or sliding required.
3. With at least two people, carefully lift and rotate the bench to the upright position while holding the legs securely in place.

