

ASSEMBLY INSTRUCTIONS

UPHOLSTERED BED

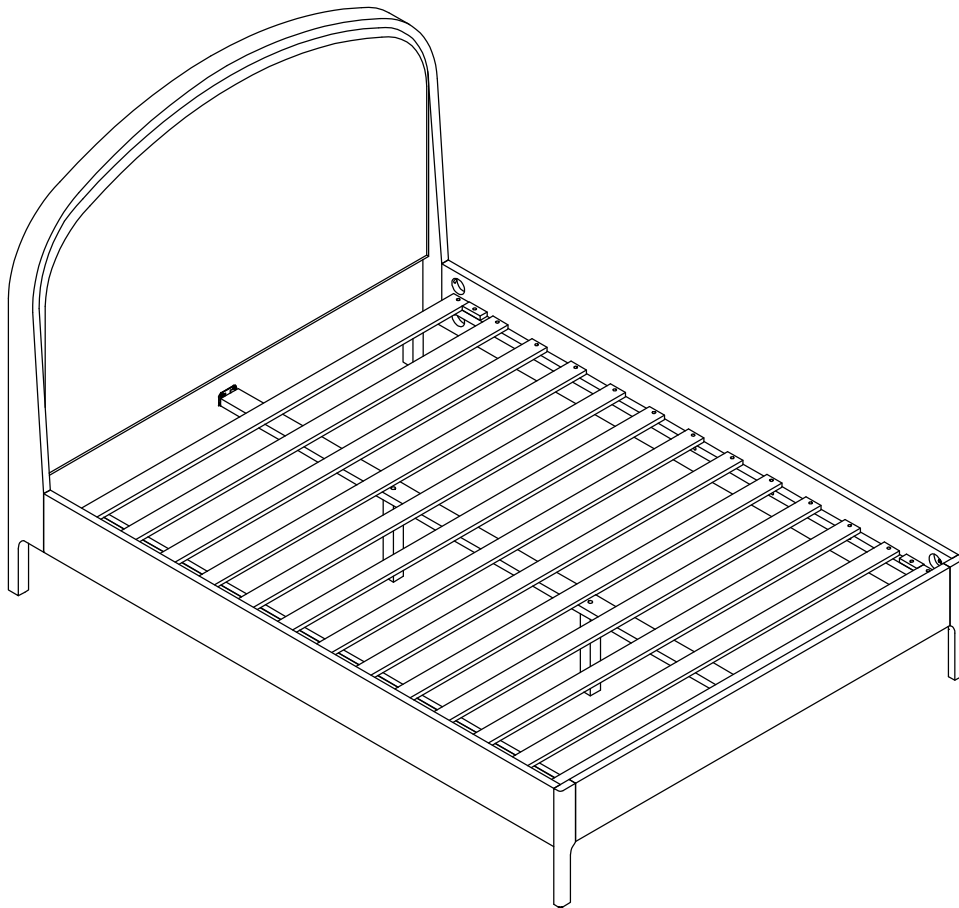

UPHOLSTERED BED

ASSEMBLY INSTRUCTIONS

Please kindly read these instructions carefully and keep for future reference. Refer to parts inventory for guidance, and ensure you have all pieces before starting.

When assembling, place all parts on a soft, clean, and flat surface such as a carpet to prevent scratches.

If you're having difficulty, our friendly Customer Care team is always here to help.

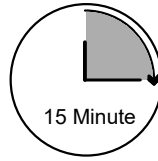



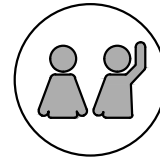

TIME

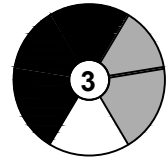





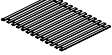

OF PEOPLE



DIFFICULTY

CODE	PART LIST	Q'TY
①	HEADBOARD 	1 PC
②	SIDE RAIL 	2 PCS
③	FOOTBOARD 	1 PC
④	CENTER SUPPORT 	1 PC
⑤	CENTER LEG 	2 PCS
⑥	SLATS 	1 PC

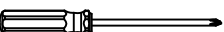
CODE	HARDWARE LIST	Q'TY
Ⓐ	HANGER BOLTS M8x90 	8 PCS
Ⓑ	HALF ROUND WASHER M8 	8 PCS
Ⓒ	SPRING WASHER 8.5 	8 PCS
Ⓓ	HEX NUT M8x13 	8 PCS
Ⓔ	SCREW M4x25 	26 PCS
Ⓕ	OPEN WRENCH 	1 PC
	SCREW DRIVER (NOT INCLUDED) 	

Note: Make sure you have all the parts and hardware with quantity listed above before assembling the product. A screwdriver is also required (not included)

UPHOLSTERED BED

STEP 1

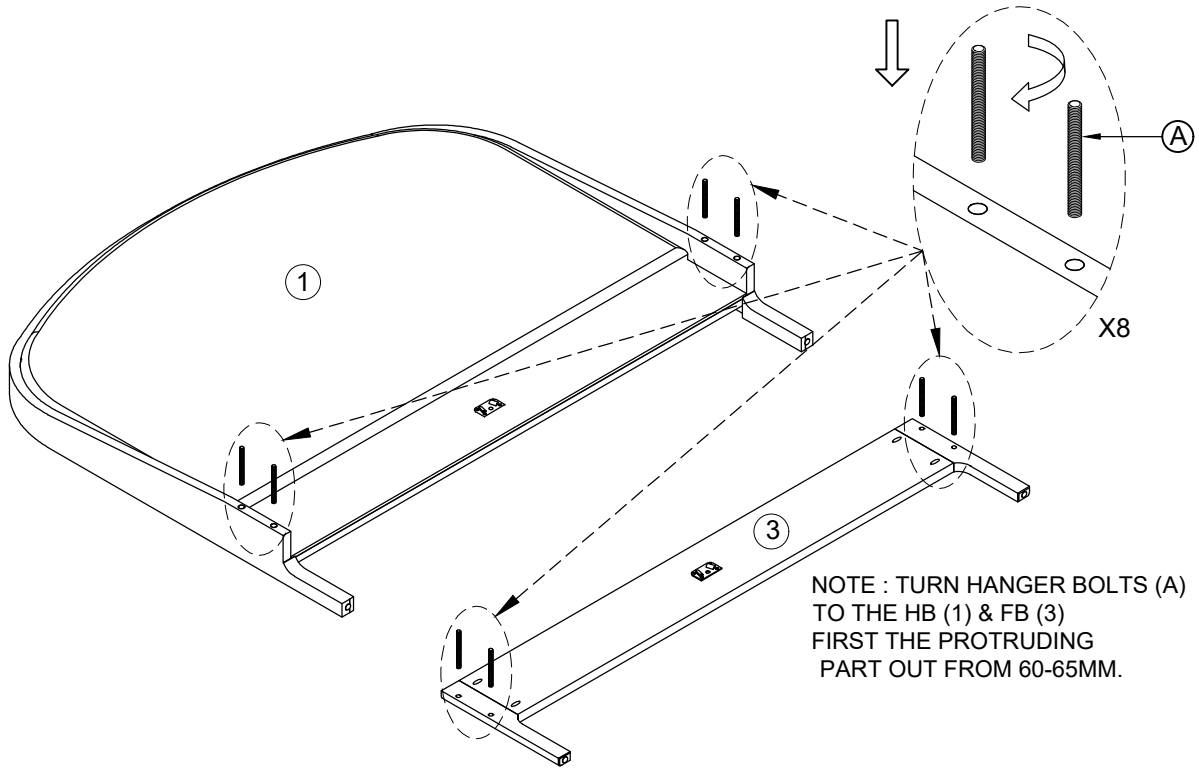

STEP 2

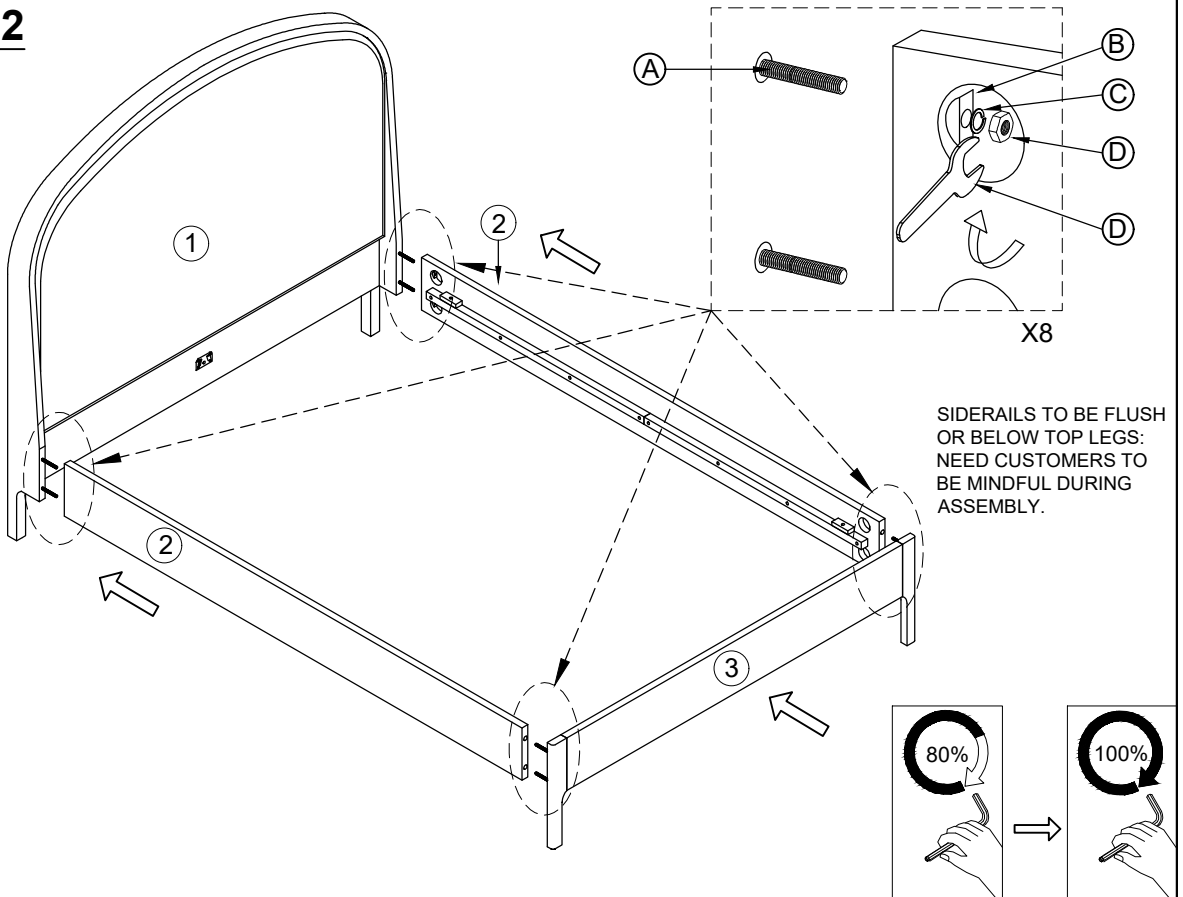

NOTE: FIRST, TIGHTEN ALL BOLTS TO 80% THEN TIGHTEN ALL BOLTS TO 100%
-PLEASE FOLLOW THE STEPS ABOVE TO AVOID THE ASSEMBLY DIFFICULTY.

UPHOLSTERED BED

STEP 3

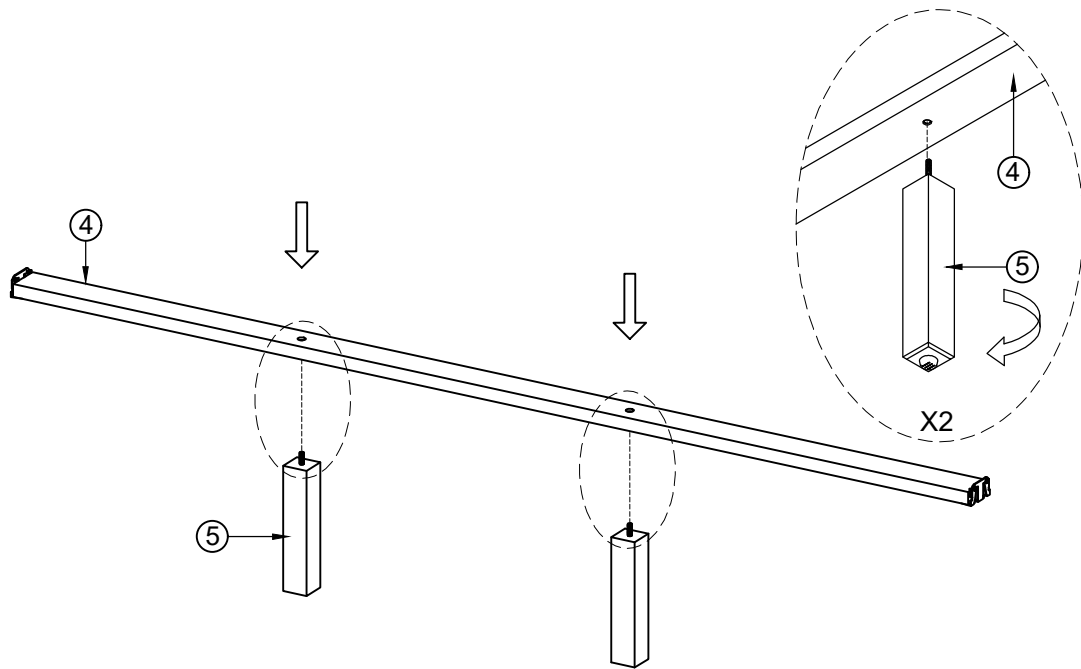

STEP 4

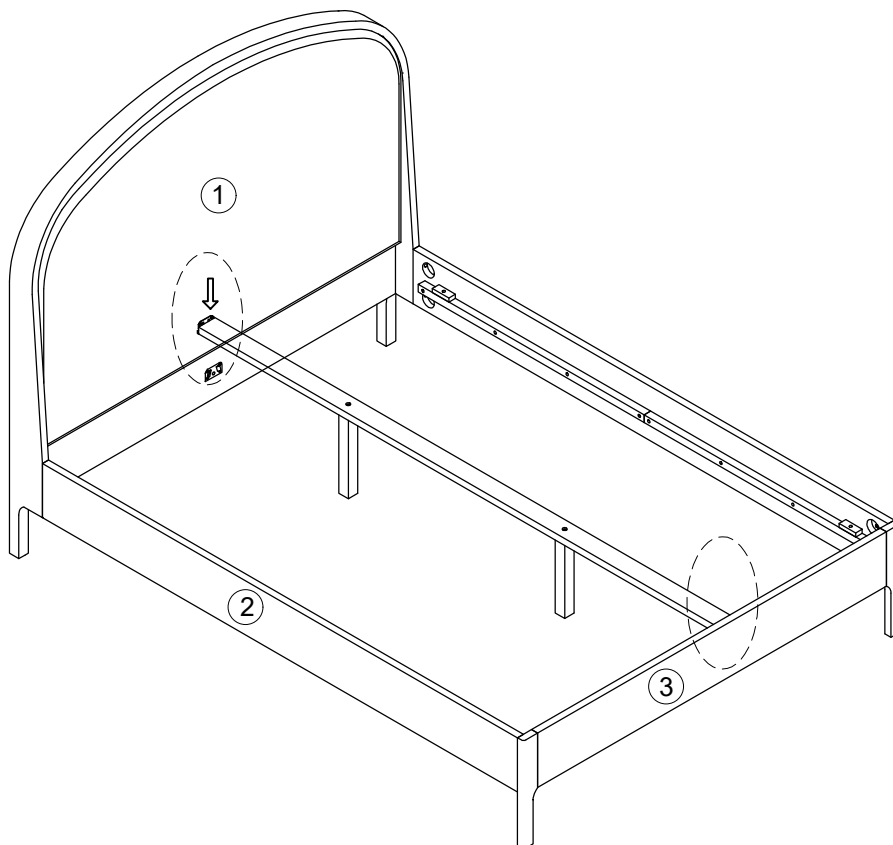

UPHOLSTERED BED

STEP 5 & FINISH

