

ASSEMBLY INSTRUCTION

DEAR CUSTOMER

Thank you for purchasing our product. Please read this assembly instruction carefully before assemble and use, and keep it for future reference.

Tips:

1. Please check whether the outer packaging is intact before opening to avoid damage during transportation.
2. Assemble this product on a flat and clean surface to avoid scratching. It is recommended for one or two people to assemble.
3. After unpacking, please confirm in time all the parts and hardware are included. Please do not discard any packaging, if for any reason you need to return this product, it must be returned in its original packaging.
4. If you have any questions about the products, please send an email to AfterSales317@outlook.com on the website!
5. Please keep small parts out of reach of children or pets to prevent them from swallowing.
6. Please read the installation steps in the Instruction carefully and follow the steps in the Instruction to assemble.

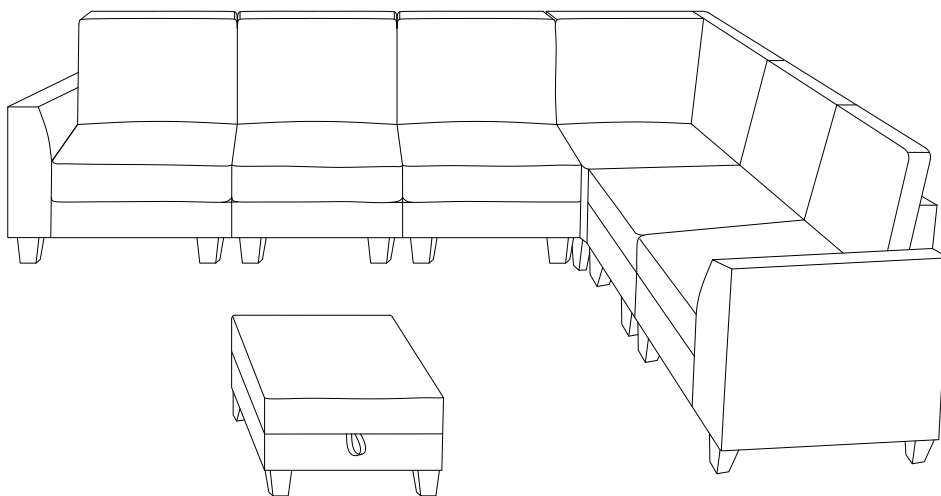

Box 1: Unpacking

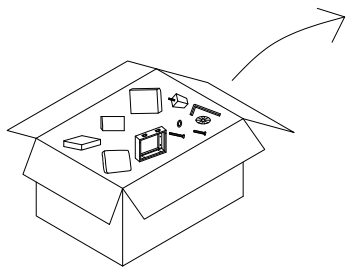

Box 1
SF025-08L

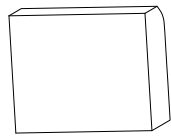

(A) Left Armrest

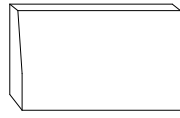

(B) Back Frame

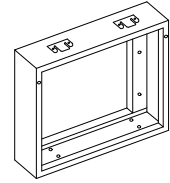

(G) Left Seat Frame

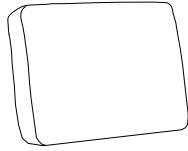

(L) Back Cushion

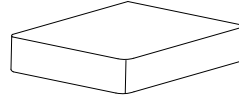

(O) Seat Cushion



(Q) Sofa Leg x4

Hardware Bag:

(S) Bolt

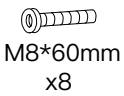

(T) Bolt



(R) Flat Washer



(U) Allen Wrench

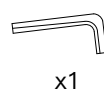

(W) Anti-slip Gasket



Assembly Step 1



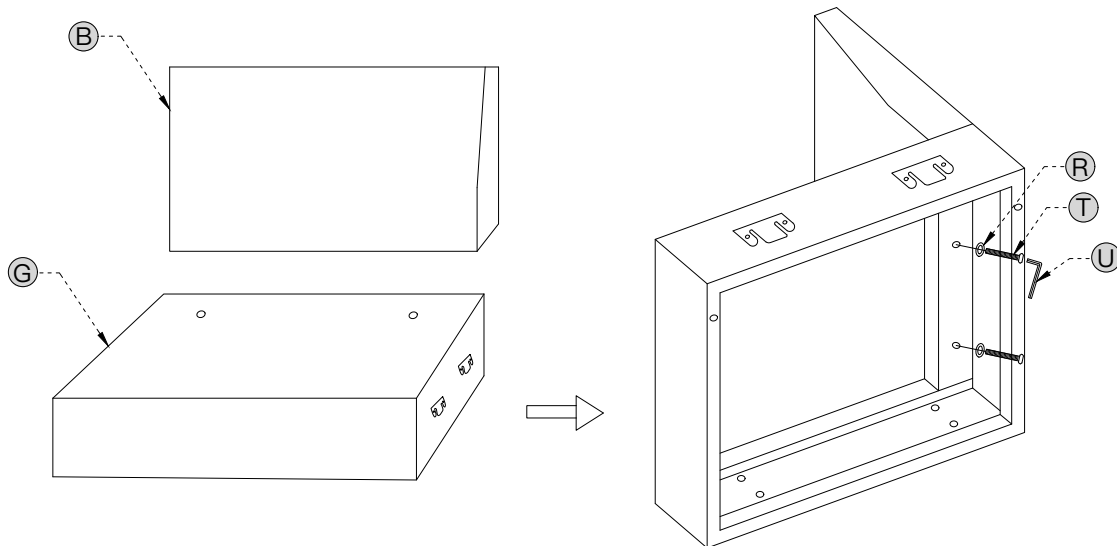

STEP 1 Place the left seat frame (G) on its side and the back frame (B) behind the seat frame. Then tighten the flat washer (R) and bolt (T) into the corresponding screw holes clockwise with allen wrench (U).

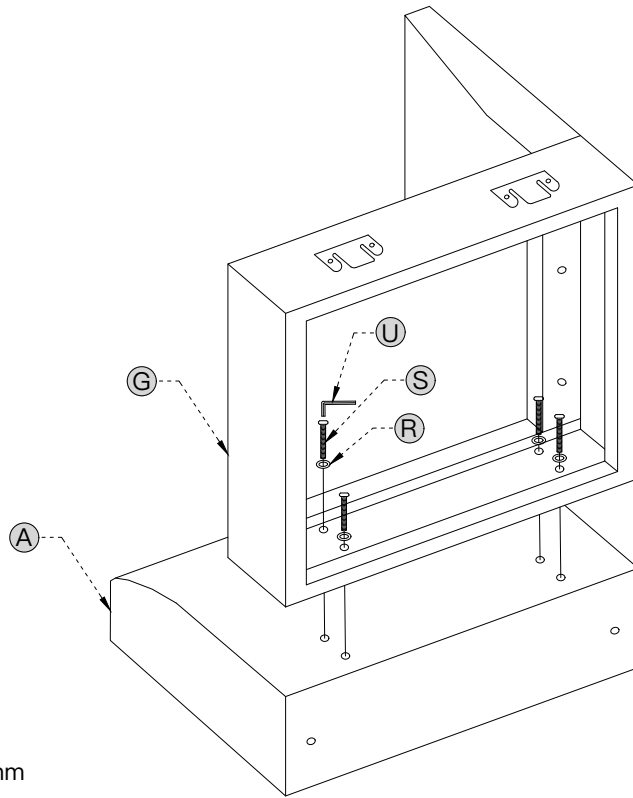

B		x1	
G		x1	
T		x2	M8x70mm
R		x2	



STEP 2 Place the left armrest (A) flat. Place the left seat frame (G) sideways on the armrest. Then tighten the flat washer (R) and bolt (S) clockwise into the corresponding screw holes with allen wrench (U).

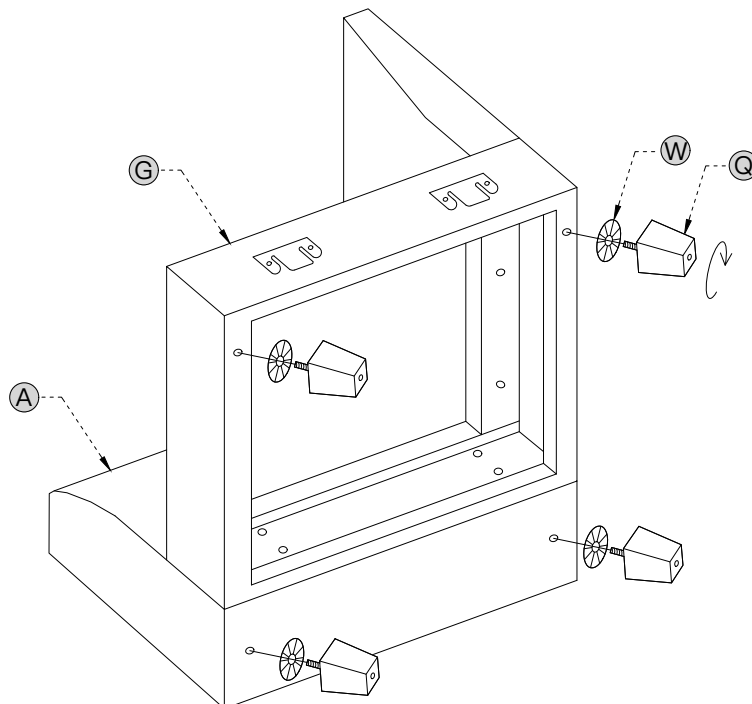

A		x1
G		x1
S		x4 M8x60mm
R		x4

STEP 3 Place the anti-slip gasket (W) and the sofa legs (Q) into the mounting holes and tighten them clockwise.



Q		x4
W		x4

Box 2: Unpacking

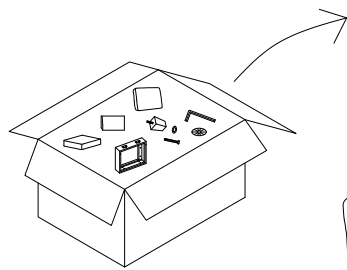

Box 2
SF025-09

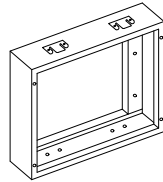

(H) Medium Seat Frame x2

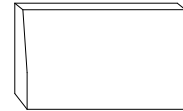

(B) Back Frame x2

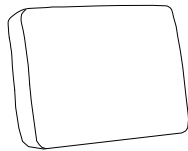

(L) Back Cushion x2

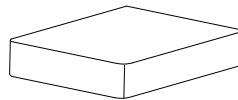

(O) Seat Cushion x2



(Q) Sofa Leg X8

All installation parts are placed in this box 1. (SF025-08L)

(T) Bolt

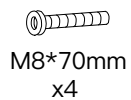

(R) Flat Washer



(U) Allen Wrench



(W) Anti-slip Gasket



x8

Assembly Step 2

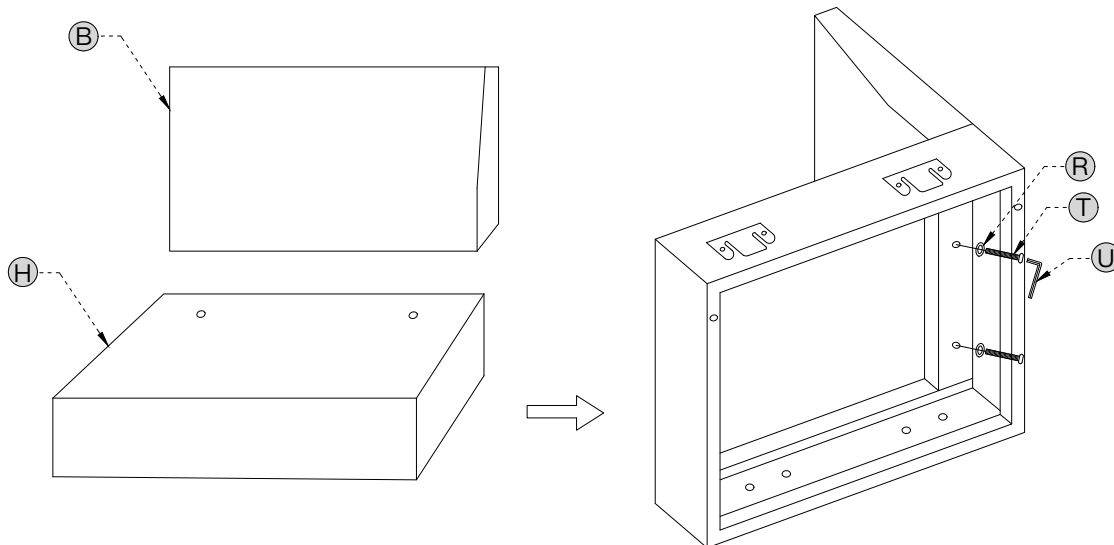

STEP 4 Place the Medium Seat Frame (H) on its side, then place the Back Frame (B) behind the Seat Frame to align it. Then tighten the flat washer (R) and bolt (T) clockwise into the corresponding screw holes with allen wrench (U).

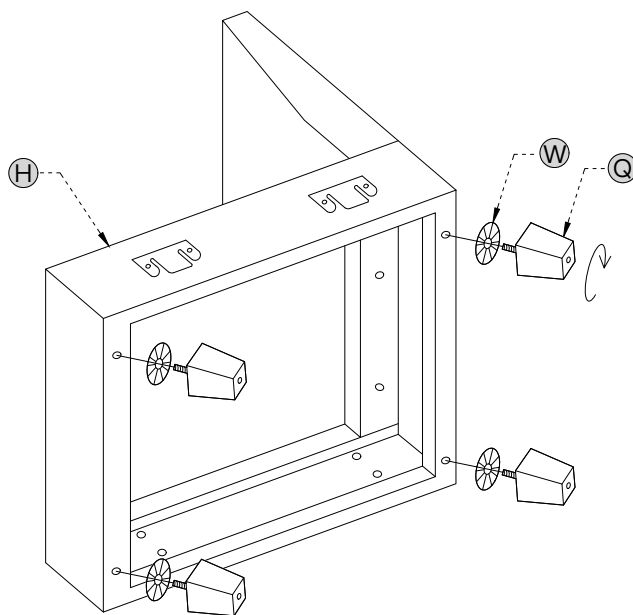

B		x2	
H		x2	
T		x4	M8x70mm
R		x4	

STEP 5 Place the anti-slip gasket (W) and the sofa leg (Q) into the mounting holes and tighten clockwise. Both two armless chair are installed in the same way.



- Q  x8
- W  x8

Box 3: Unpacking

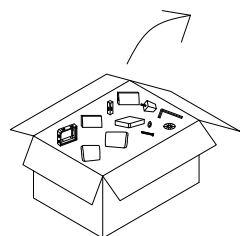

Box 3
SF025-11

I Seat Frame

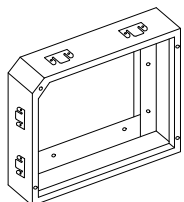

D Back Column

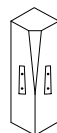

C Left Back Frame



E Right Back Frame



M Left Back Cushion

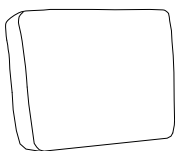

N Right Back Cushion

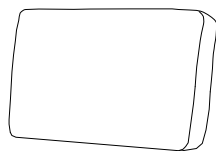

P Cushion

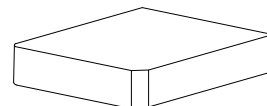

All installation parts are placed in this box 1. (SF025-08L)

T Bolt

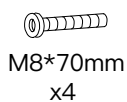

R Flat Washer



U Allen Wrench

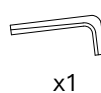

Q Sofa Leg x4



W Anti-slip Gasket



Assembly Step 3

STEP 6 Place the corner seat frame (I) on its side and align the corner back frame (C/E) with the seat frame. Then tighten the flat washer (R) and bolt (T) clockwise with allen wrench (U).

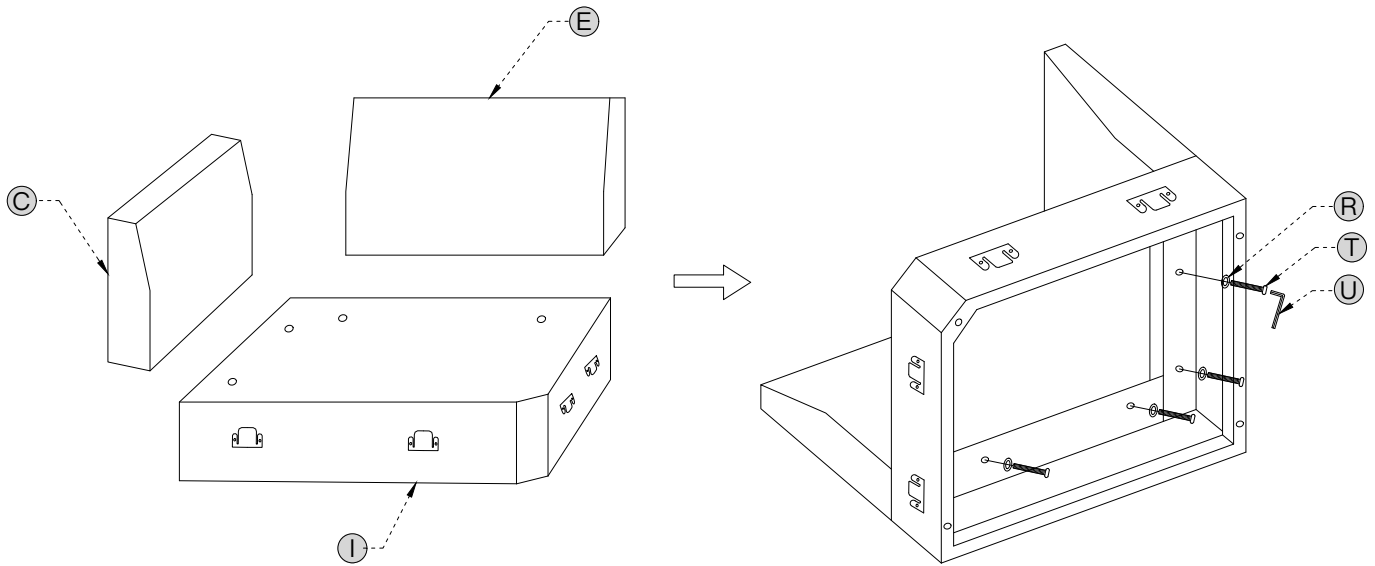

C		x1
E		x1
I		x1
T		x4 M8x70mm
R		x4

STEP 7 After completing the above steps, put the non-slip pads (W) and sofa legs (Q) into the mounting holes and tighten them clockwise. Then insert the corner post (D) inserts into the left/right corner bracket (C/E) inserts.

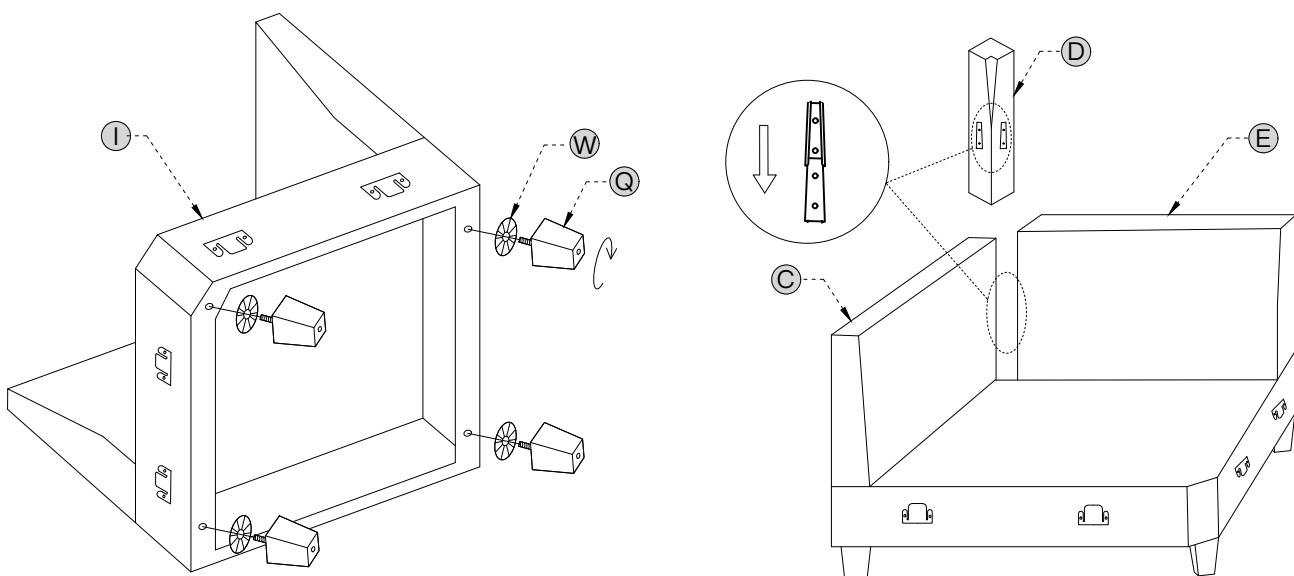

D		x1
Q		x4
W		x4

Box 4: Unpacking

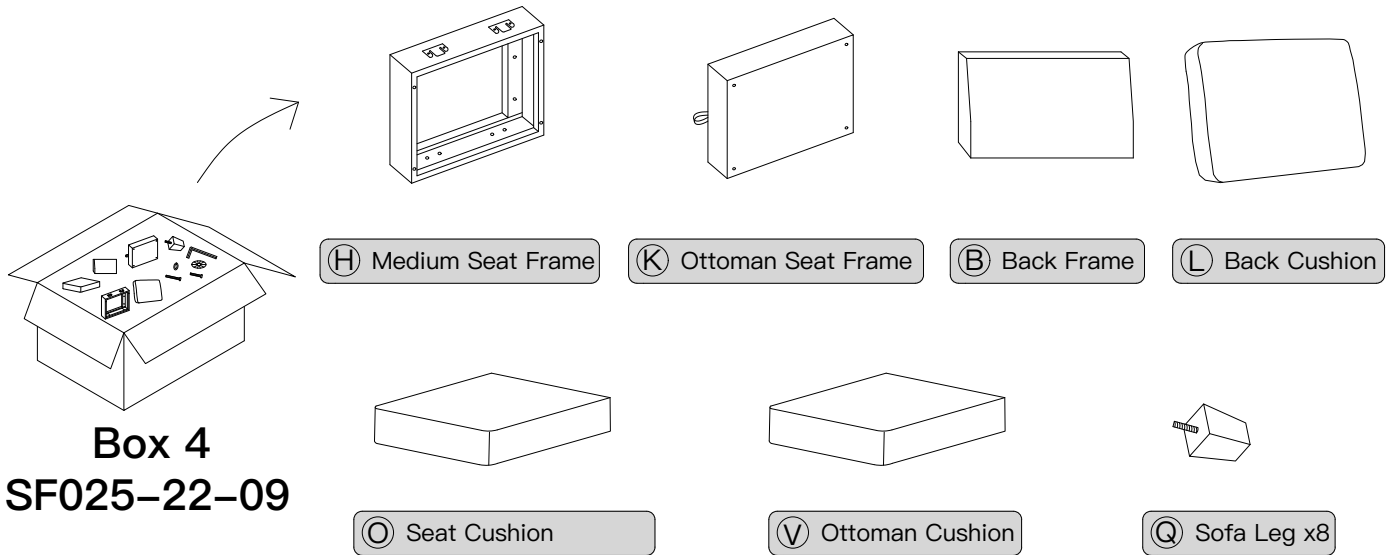

All installation parts are placed in this box 1. (SF025-08L)

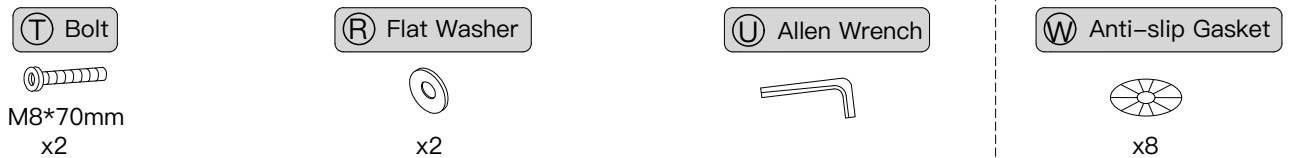

Assembly Step 4

STEP 8 Place the medium seat frame (H) on its side, then place the back frame (B) behind the seat frame to align it. Then tighten the flat washer (R) and bolt (T) clockwise into the corresponding screw holes with allen wrench (U).

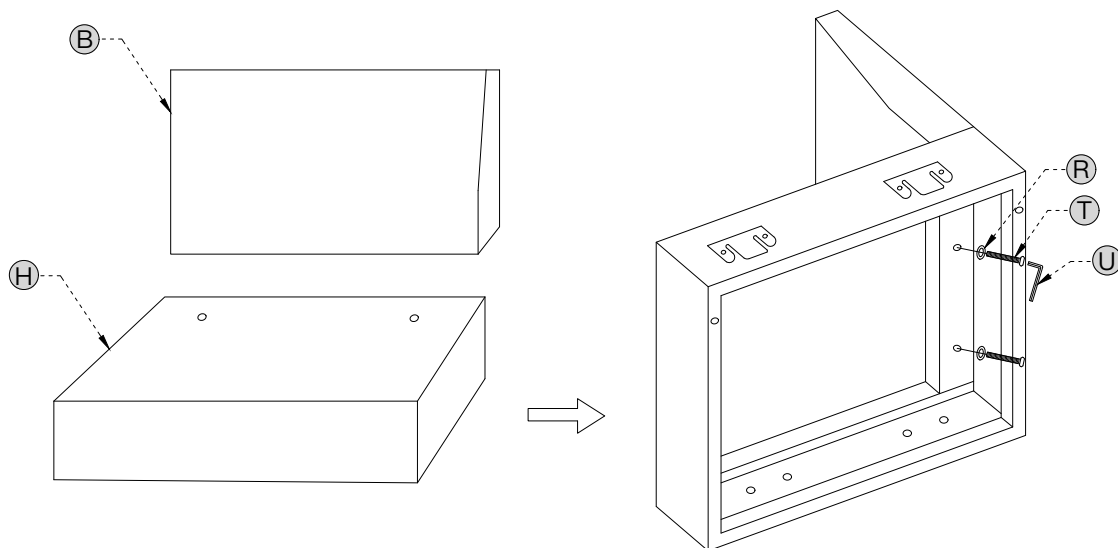

B		x1	
H		x1	
T		x2	M8x70mm
R		x2	

STEP 9 Place the anti-slip gasket (W) and the sofa leg (Q) into the mounting holes and tighten clockwise.

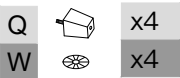
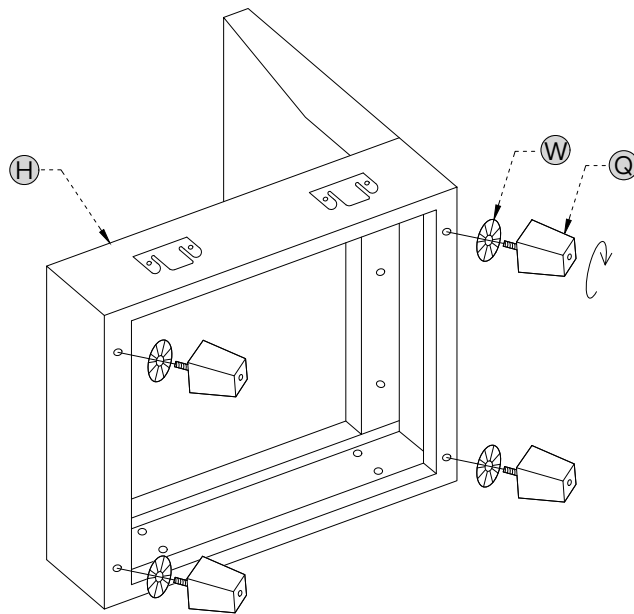

STEP 10 Place the ottoman seat frame (K) on its side and tighten the anti-slip gasket (W) and the sofa leg (Q) clockwise to the mounting holes.

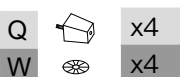
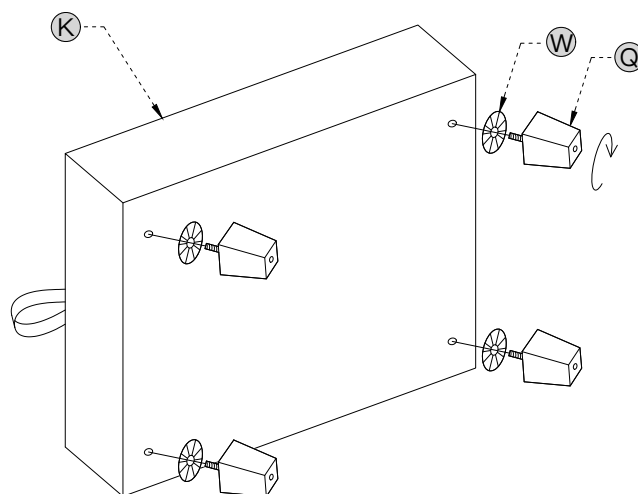

Box 5: Unpacking

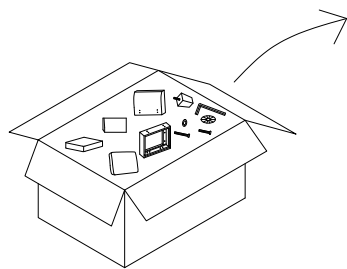

Box 5
SF025-08R

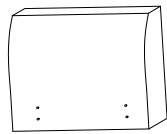

F Right Armrest

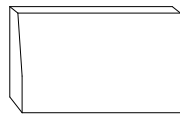

B Back Frame

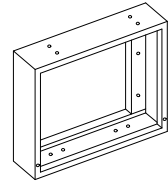

J Right Seat Frame

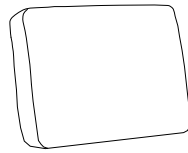

L Back Cushion

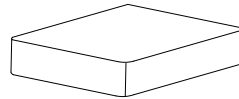

O Seat Cushion



Q Sofa Leg x4

All installation parts are placed in this box 1. (SF025-08L)



S Bolt
M8*60mm
x4



T Bolt
M8*70mm
x2



R Flat Washer
x6

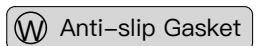

W Anti-slip Gasket
x4

Assembly Step 5

STEP 11 Place the right seat frame (J) on its side and align the back frame (B) behind the seat frame. Then tighten the flat washer (R) and bolt (T) clockwise into the corresponding screw holes with allen wrench (U).

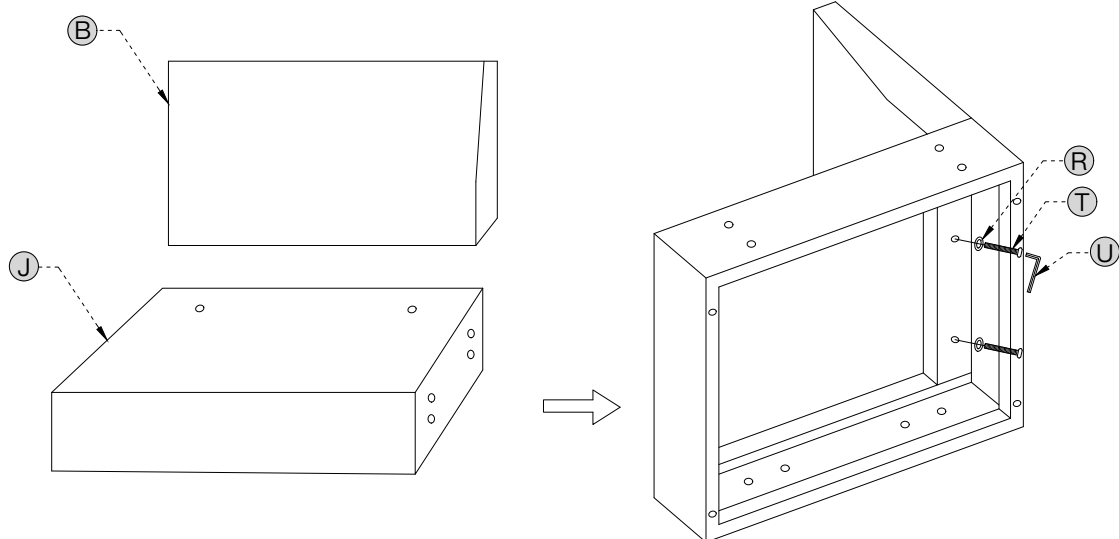

B		x1	
J		x1	
T		x2	M8x70mm
R		x2	

STEP 12 Lay the right armrest (F) flat and place the right seat frame (J) sideways on the armrest. Then tighten the flat washer (R) and bolt (S) clockwise into the corresponding screw holes with allen wrench (U).

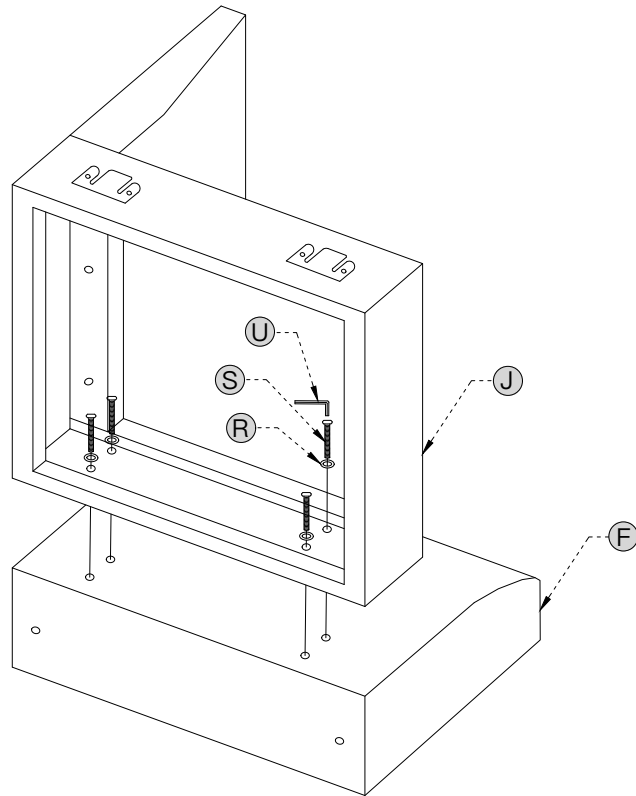

A		x1
J		x1
S		x4 M8x60mm
R		x4

STEP 13 Place the anti-slip gasket (W) and the sofa leg (Q) into the leg mounting holes and tighten clockwise.

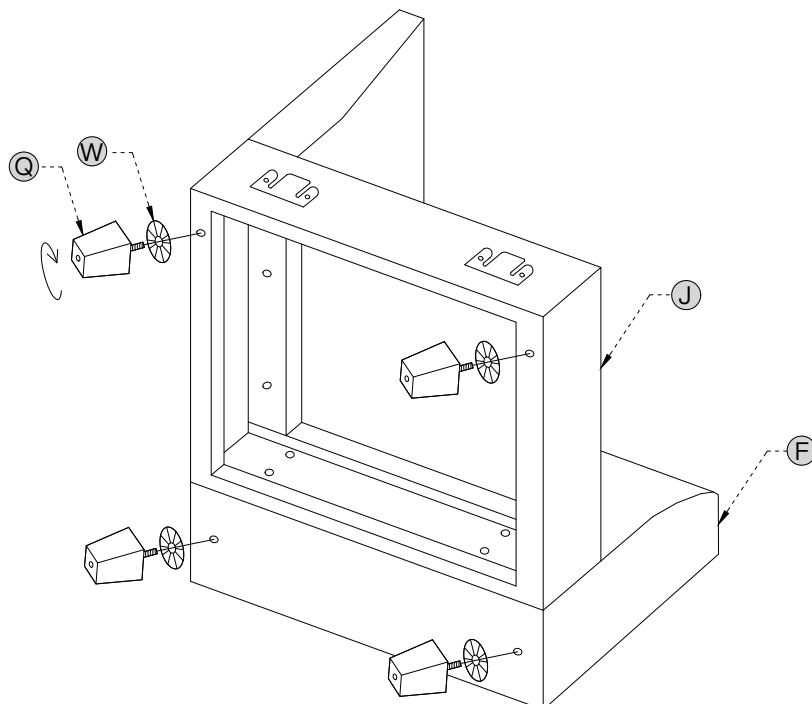

Q		x4
W		x4

Box 6: Unpacking

STEP 14 After completing all the above steps, insert the side inserts of the seat frame (G/H/I/J) into the adjacent inserts. Then place the seat cushion (O/P/V) and the back cushion (L/M/N) in the corresponding positions.

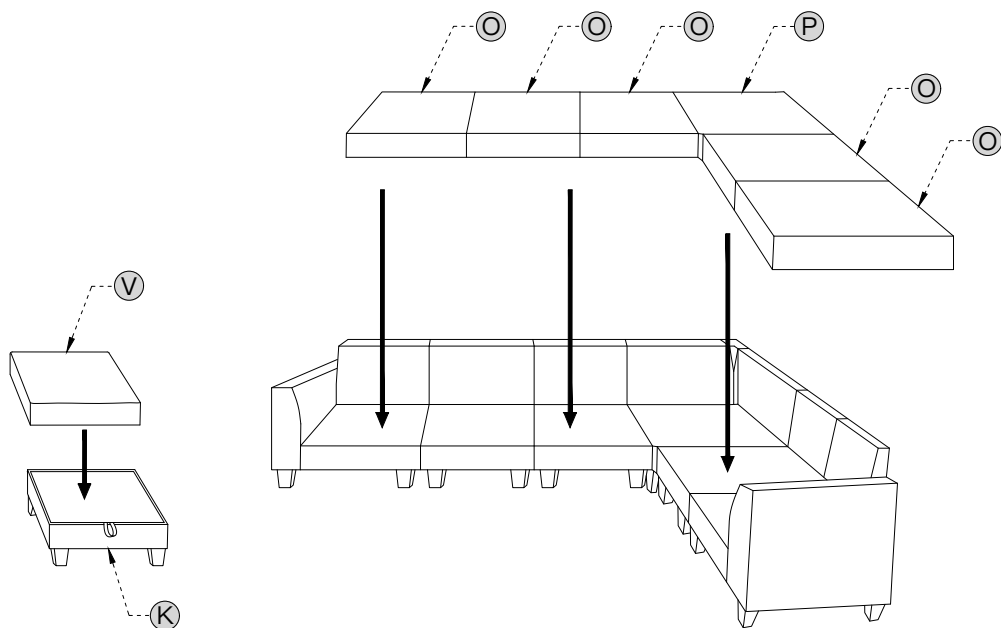
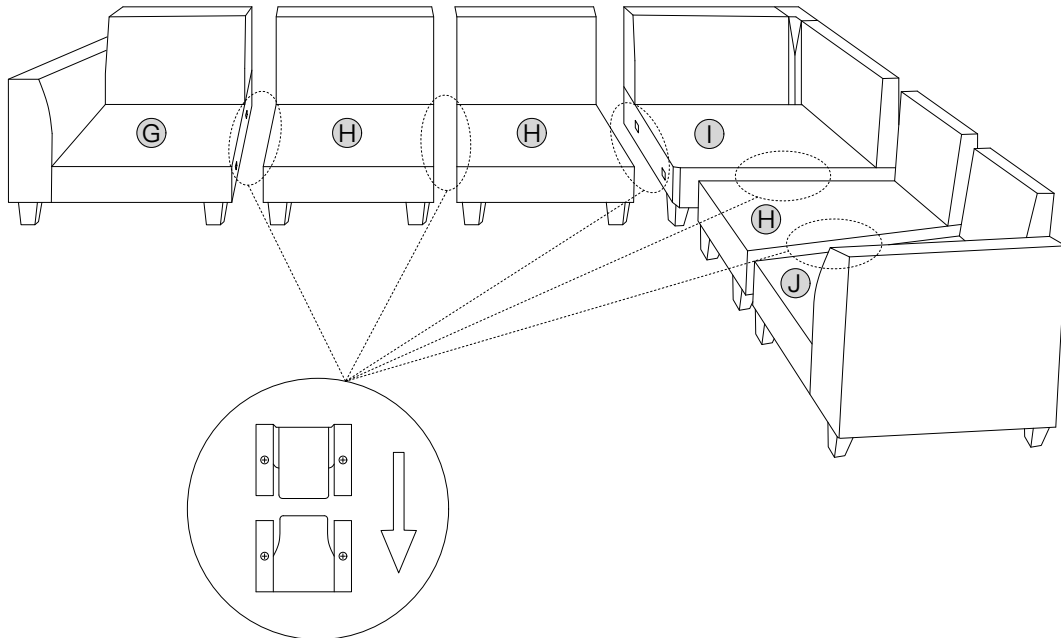

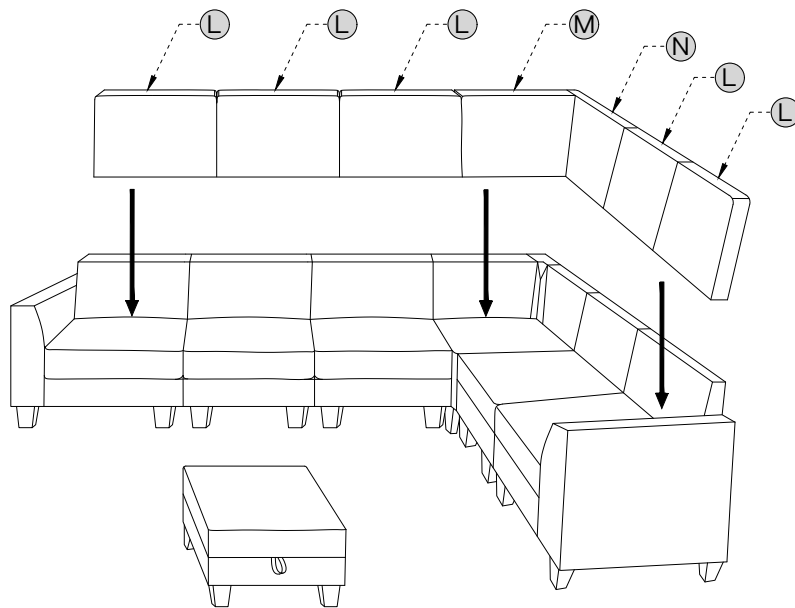

O		x5
P		x1
V		x1
L		x5
M		x1
N		x1

Assembly completed!

Please enjoy your sofa