

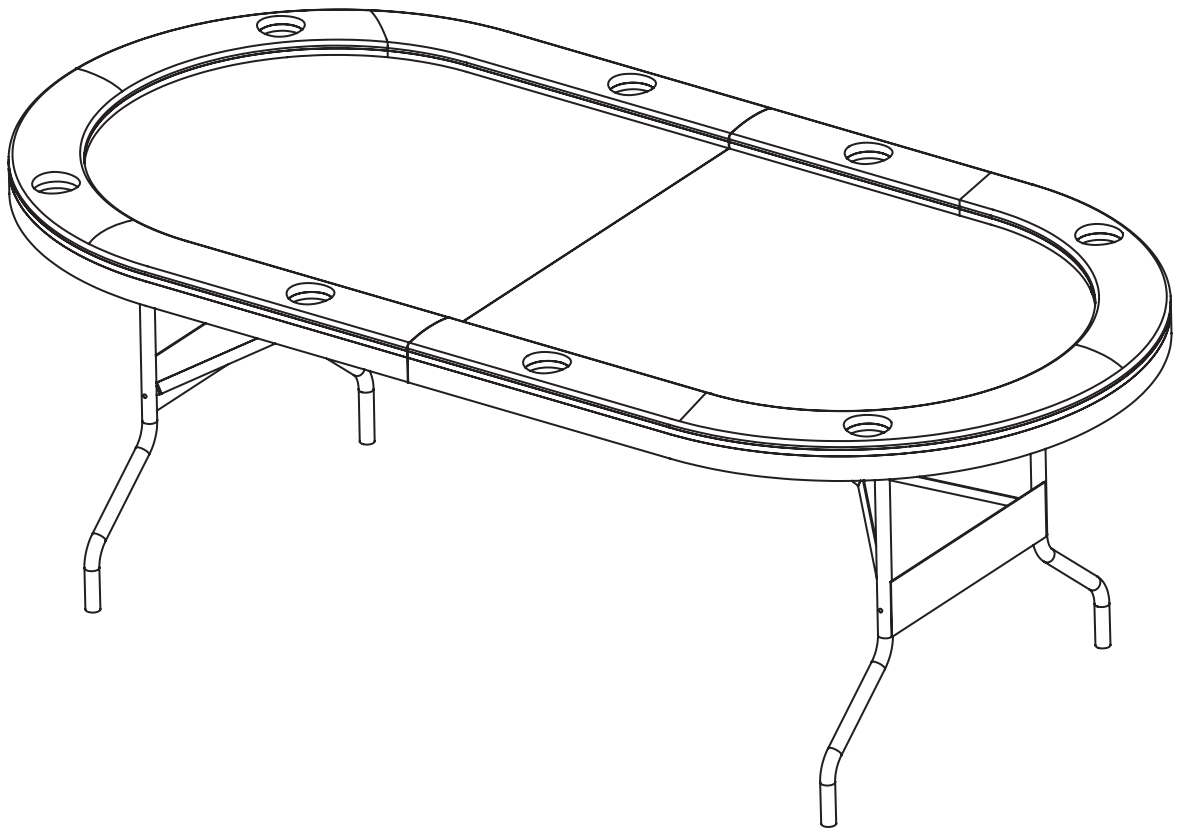

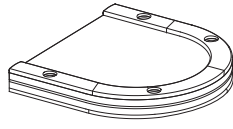



Assembly Instructions

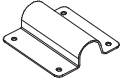

PARTS IDENTIFIER

PART NUMBER NÚMERO DE PIEZA	1	FOR FIG. 1
PART PIEZA		
PART NAME	x1 Folded Poker Table	

PRE-INSTALLED PARTS

P1  FOR FIG. 3 x4 "U" Bracket	P2  FOR FIG. 3 x16 3.5x12mm Screw	P3  FOR FIG. 1 X8 Cup Holder	P4  FOR FIG. 3 x4 Outer Leg Cap
P5  FOR FIG. 2 x2 Steel Wire - A	P6  FOR FIG. 2 x2 Steel Wire - B	P7  FOR FIG. 2 x1 Butterfly Nut	

BEFORE ASSEMBLY

1. Find a clean, level place to begin the assembly of your product.
2. Verify that you have all listed parts as shown on the part list pages. If any parts are missing, call our customer service.

FIG. 1

ASSEMBLY

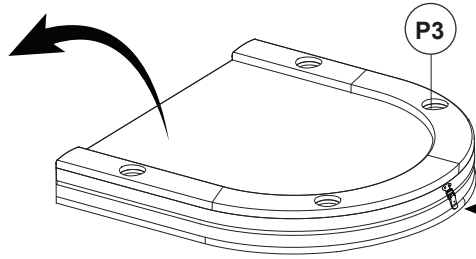
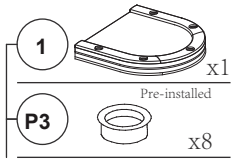

Note: Unfold the Folded Poker Table (1).

FIG. 2

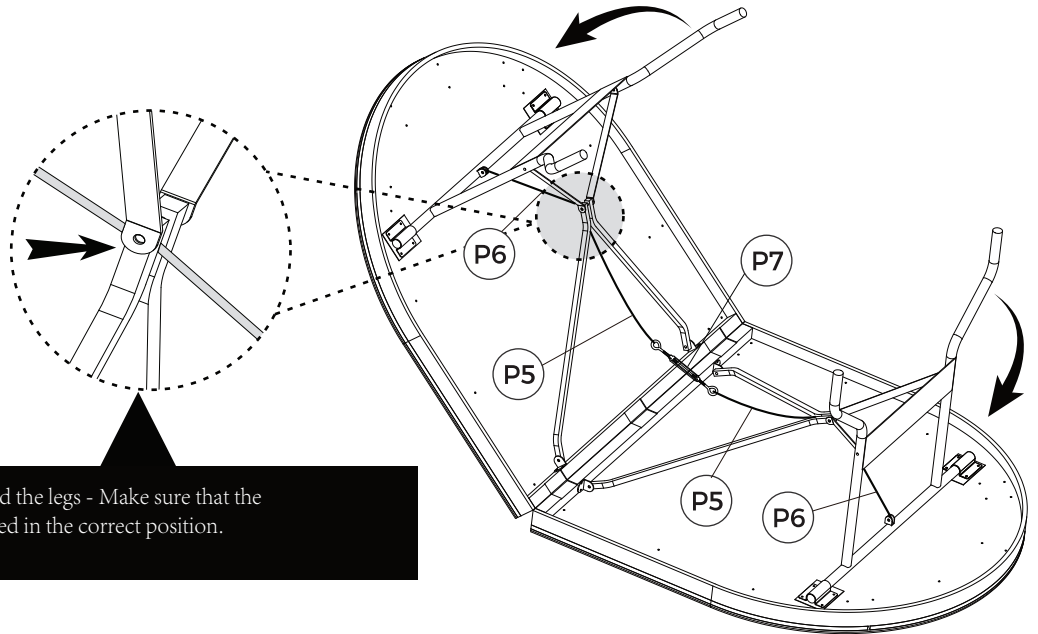
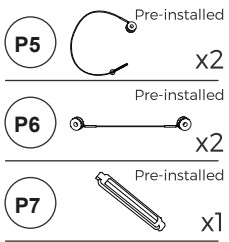

Note: To unfold the legs - Make sure that the hinges are locked in the correct position.

FIG. 3

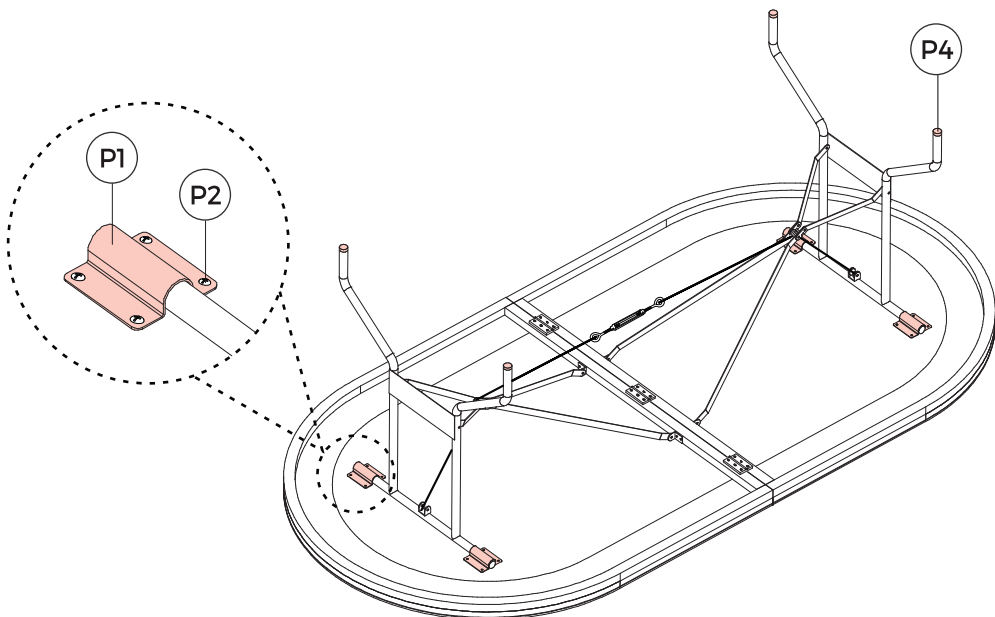
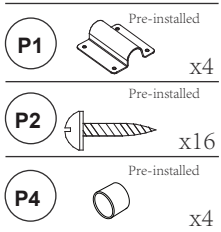

ASSEMBLY

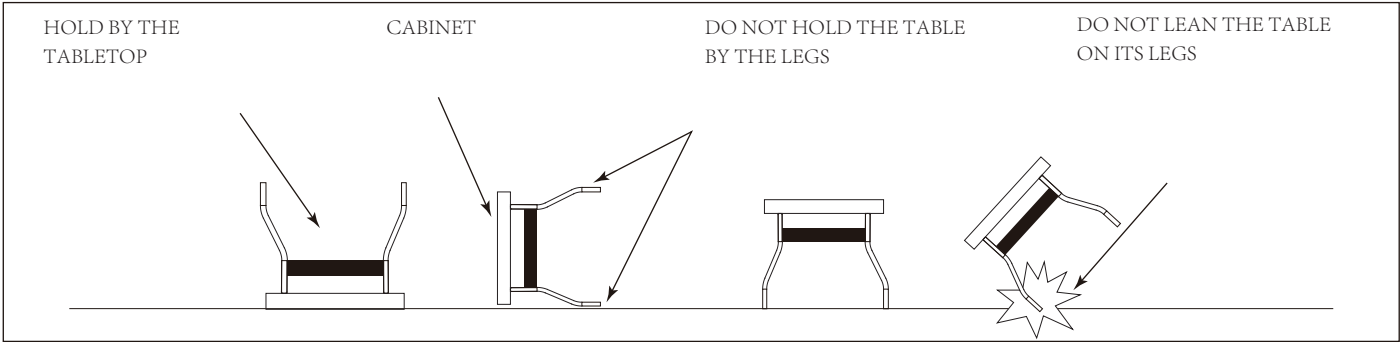
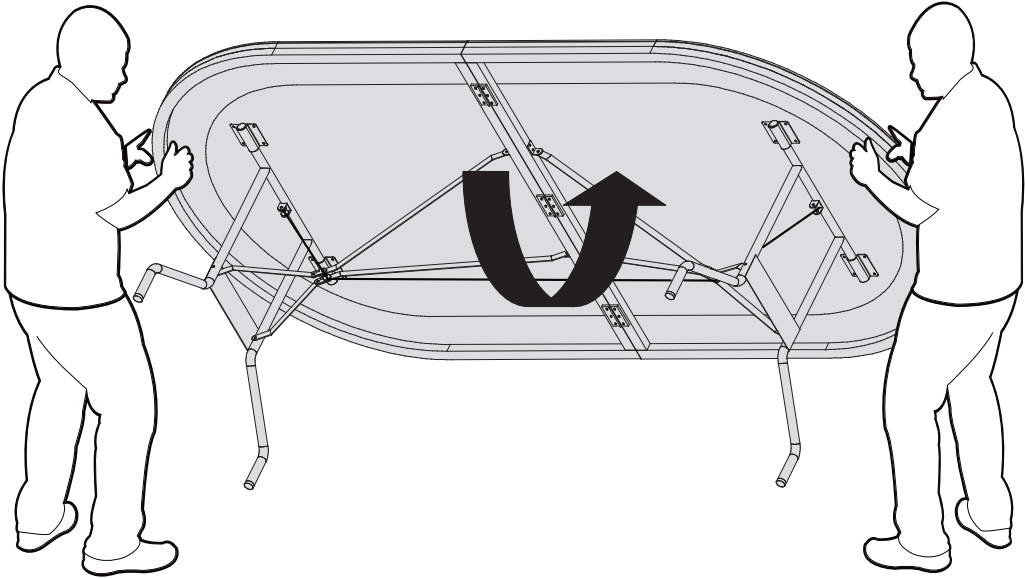

⚠ CAUTION

Two strong adults are recommended to turn the table over as shown.

1. Lift the table off the ground.
2. Turn the table over.
3. Place it on all four feet at the same time on the ground.

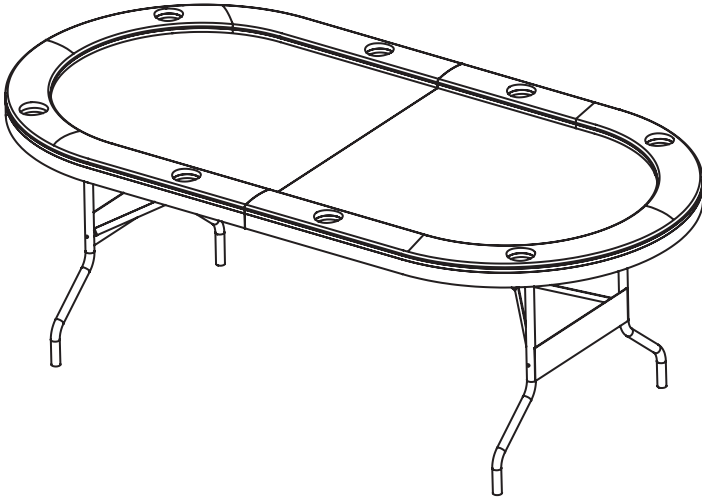

HOW TO LEVEL YOUR TABLE

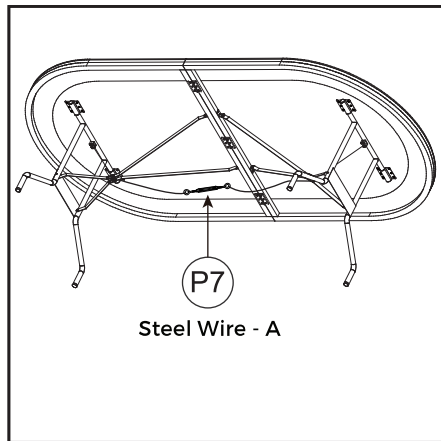

When the steel wire is too tight, place the side edge of the Table against the ground first (pay attention to protecting the product), then fold it inward and loosen the steel wire for adjustment.

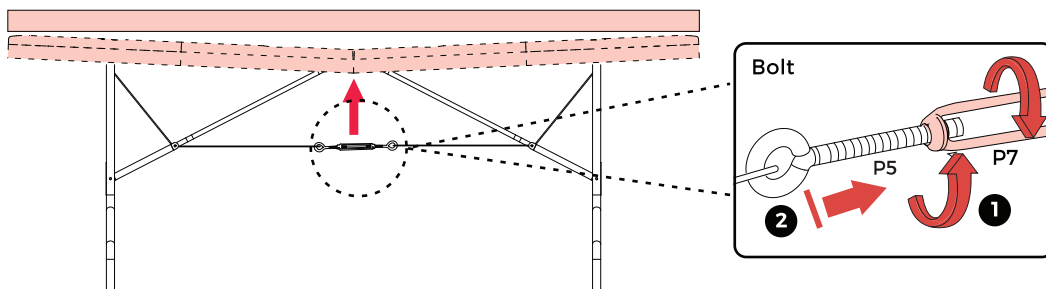

ADJUST CONCAVE TABLE

1. Loosen P7 and P5
2. Push the Bolt inwards until the playfield is even.
3. Tighten P7 and P5.

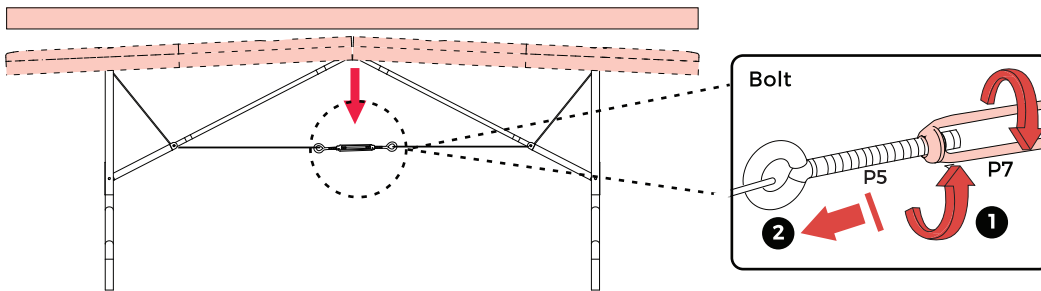

ADJUST CONVEX TABLE

1. Loosen P7 and P5.
2. Pull the Bolt outwards until the playfield is even.
3. Tighten P7 and P5.