

NOTICE

- *Please make sure that you have all parts indicated and they are in good condition before you begin assembly of this item. Refer to part list and hardware list below for guidance.
- *This item should be assembled on a soft surface to prevent scratching the finish during assembly.
- *This item may require periodic tightening.
- *If you are having difficulty, our friendly Customer Care team is always here to help.





PREPARATION

- *Before beginning assembly of product, make sure all parts are present. Compare parts with part contents list and hardware contents list.
- *If any part is missing or damaged, do not attempt to assemble the product.
- *Estimated Assembly Time: 30minutes.
- *Tools Required for Assembly (included): Allen Key

CARE AND MAINTENANCE

Store outdoor furniture indoors or cover well when not in use. Remove wooden furniture from standing water. Dust regularly with small brush or vacuum. Spills should be taken care of immediately before they harden or stain with a slightly dampened sponge.

Part List and Hardware List

PIECE	DESCRIPTION	PICTURE	QUANTITY
A	Table Top		1
B	Table Leg		4
C	Connector		2
HW1	Bolt	 M6*40	8
HW2	Allen Key		1

Chair: 23 56"x26 .67"x40"
Table: Dia35 56'x31.11"

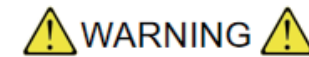

Weight Capacity:
Chair:220LBS
Table:110LBS
Warning: Do not stand on the table
Warning: Do not over torque bolts

PREPARATION

*Before beginning assembly of product, make sure all parts are present. Compare parts with part contents list and hardware contents list.

*If any part is missing or damaged, do not attempt to assemble the product.

*Estimated Assembly Time: 30 minutes.

*Tools Required for Assembly (included): Allen Key

*If you are having difficulty, our friendly Customer Care team is always here to help.

*Gradually tighten bolts in a star pattern: tighten one bolt and then the one opposite from it until all bolts are tightened.

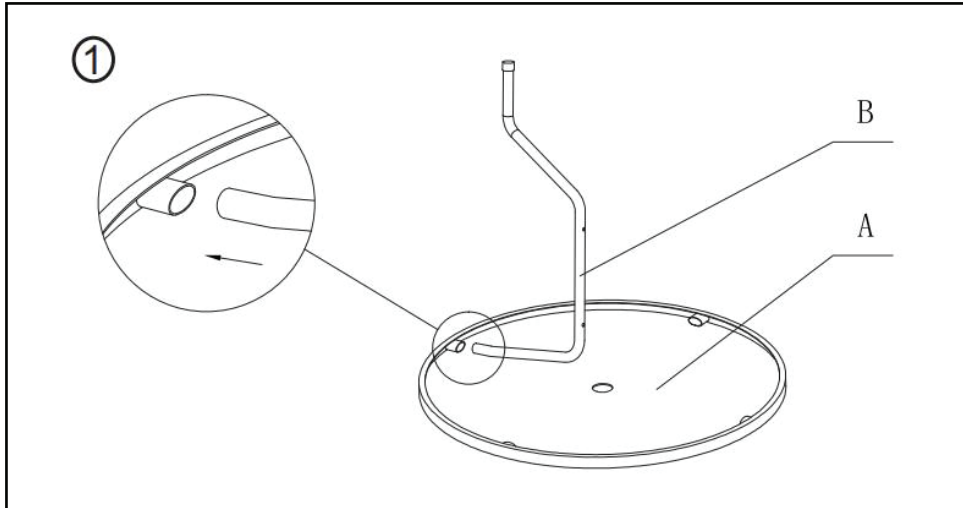

STEP1: Assemble the table leg(B) to the table top(A),using bolt(HW1) and Allen key(HW2).

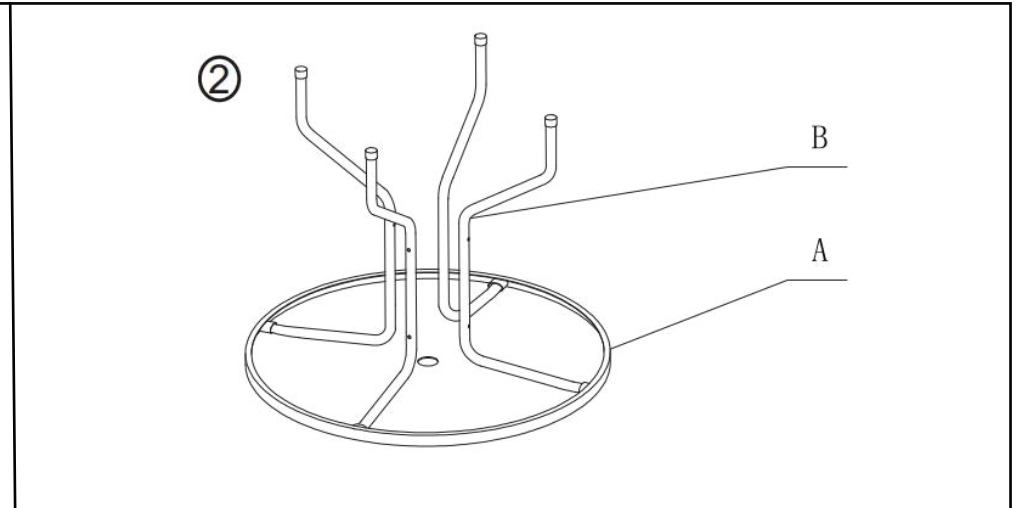

STEP2: Follow the step 1 to assemble all the legs to the table top

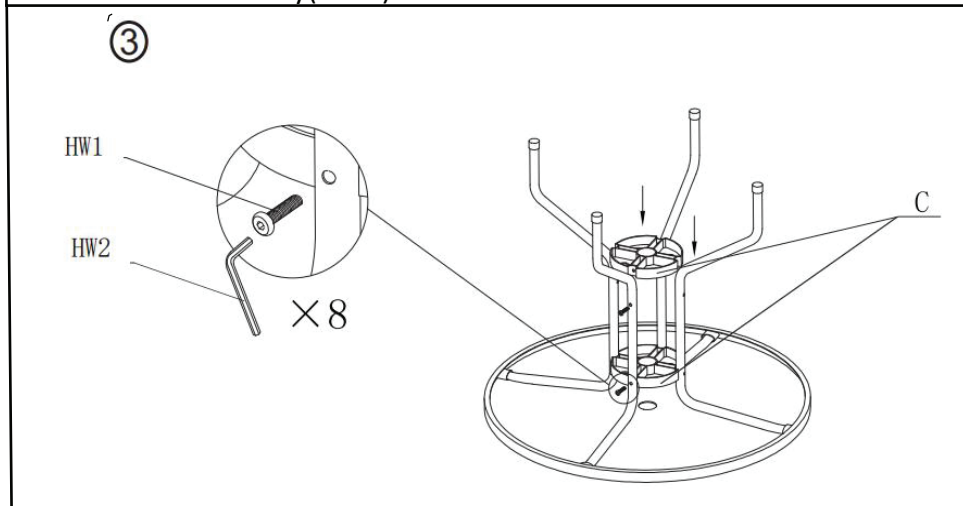

STEP3: Assemble the Connector (C) between the legs, using bolt(HW1) and Allen key (HW2)