

ASSEMBLY INSTRUCTIONS
COASTER FINE FURNITURE



Fine Furniture for every stage of life

224300Q (B1-B3)
Queen Bed

ITEM: 224300Q(B1-B3)



ASSEMBLY INSTRUCTIONS

ASSEMBLY TIPS:

1. Remove hardware from box and sort by size.
2. Please check to see that all hardware and parts are present prior to start of assembly.
3. Please follow attached instructions in the same sequence as numbered to assure fast & easy assembly.



WARNING!

1. Don't attempt to repair or modify parts that are broken or defective. Please contact the store immediately.
2. This product is for home use only and not intended for commercial establishments.







ASSEMBLY TIME

25 MINUTES

PART IDENTIFICATION



B1 (BOX 1)

A	HEADBOARD PANEL		1PC
B	LEFT HEADBOARD LEG		1PC
C	RIGHT HEADBOARD LEG		1PC
D	HEADBOARD BOTTOM RAIL		1PC

B2 (BOX 2)

E	FOOTBOARD		1PC
---	-----------	--	-----

B3 (BOX 3)

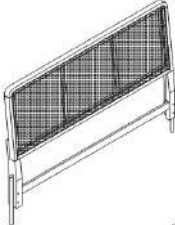
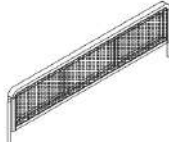
F	BED RAIL		2PCS
G	BED SLAT		4PCS
H	BED SLAT SUPPORT WITH LEVELER		2PCS
HB	224300Q(B1) *FROM BOX 1 HEADBOARD COMPLETE		1PC
E	224300Q(B2) *FROM BOX 2 FOOTBOARD*		1PC

ITEM: 224300Q (B1-B3)



ASSEMBLY INSTRUCTIONS

ASSEMBLY TIPS:

1. Remove hardware from box and sort by size.
2. Please check to see that all hardware and parts are present prior to start of assembly.
3. Please follow attached instructions in the same sequence as numbered to assure fast & easy assembly.







WARNING!



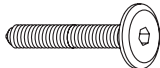

1. Don't attempt to repair or modify parts that are broken or defective. Please contact the store immediately.
2. This product is for home use only and not intended for commercial establishments.

HARDWARE IDENTIFICATION

Z-B1 (BOX 1) - HARDWARE PACK IS LOCATED IN 224300Q (B1)

1	BOLT (5/16" x 45mm - BLK)		8PCS
2	LOCK WASHER (1.6 x 14mm - BLK)		8PCS
3	FLAT WASHER (1 x 18mm - BLK)		8PCS
4	ALLEN WRENCH (M5 x 65mm - BLK)		1PC
5	WOOD DOWEL (10 x 30mm - BRW)		4PCS

Z-B3 (BOX 3) - HARDWARE PACK IS LOCATED IN 224300Q (B3)

6	FLAT HEAD SCREW (8 x 38mm - BLK)		8PCS
7	THREADED BOLT (5/16" x 100mm - WHT)		8PCS
8	HEX NUT (5/16" x 100mm - WHT)		8PCS
9	HALF ROUND NUT (22 x 17 x 10mm - WHT)		8PCS
10	WRENCH (13mm - WHT)		1PC

NOTE :

Philips head screw driver is required in the assembly process; however, manufacturer does not provide this item.

ITEM: 224300Q (B1-B3)

ASSEMBLY INSTRUCTIONS

STEP 1

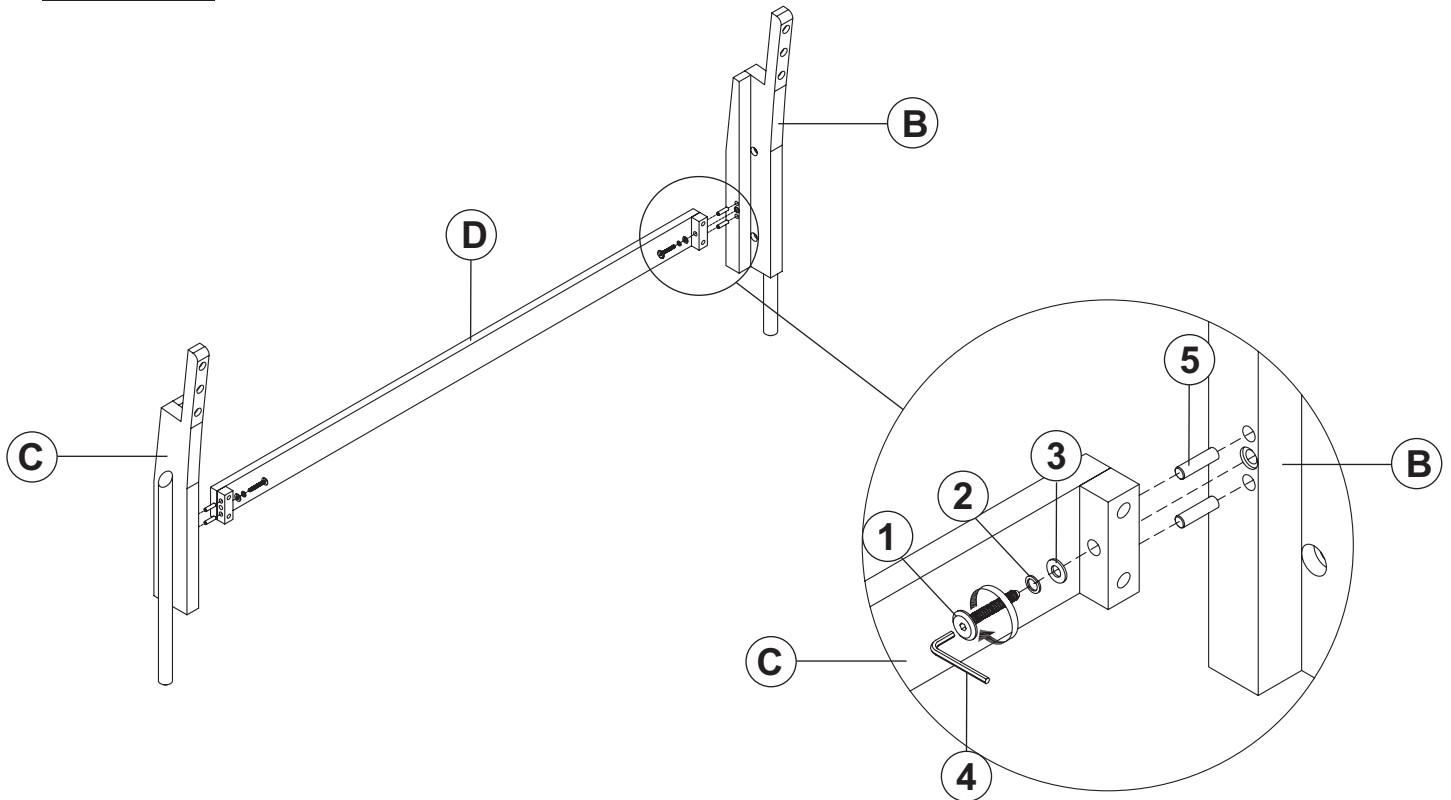

STEP 2

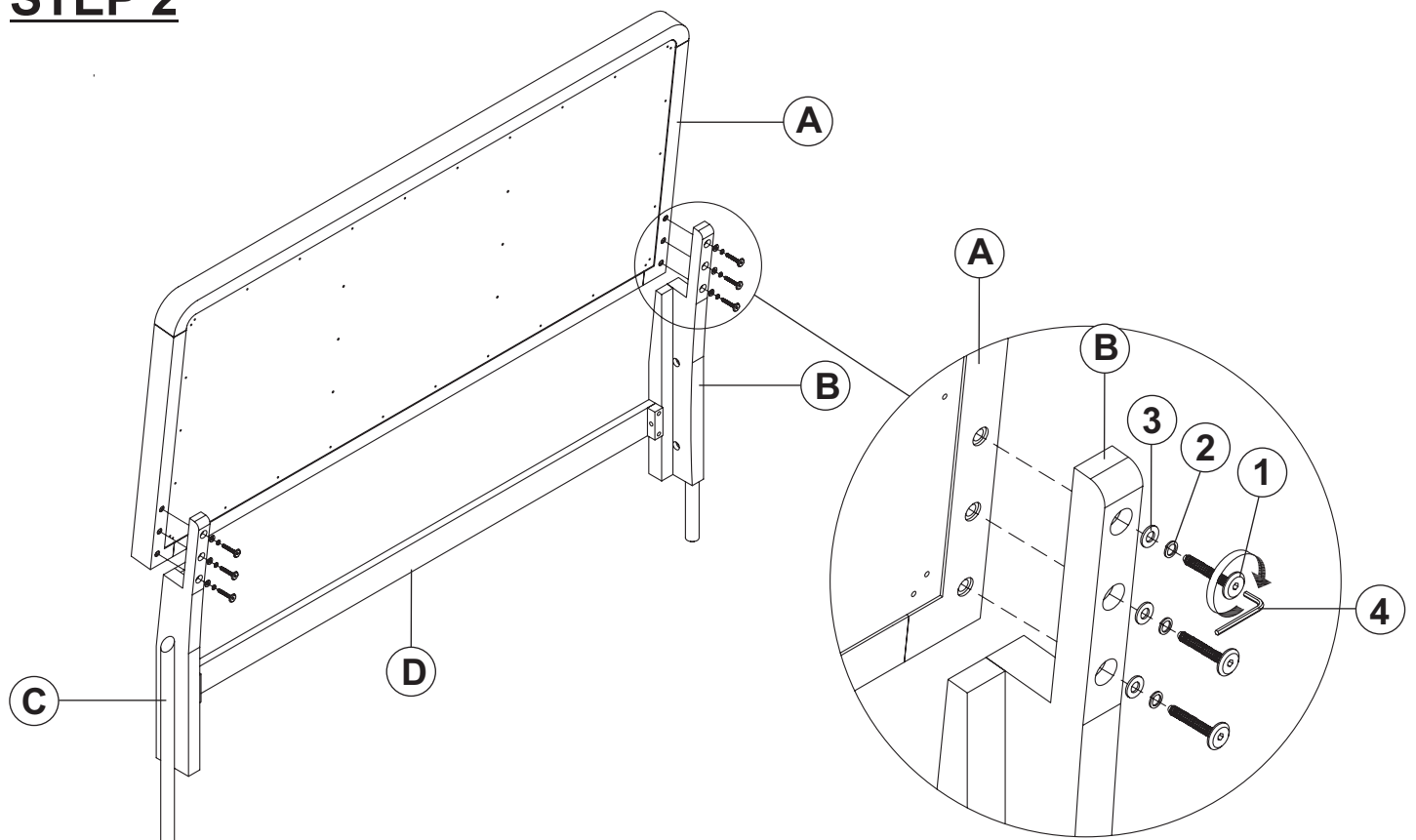

ITEM: 224300Q (B1-B3)

ASSEMBLY INSTRUCTIONS

STEP 3

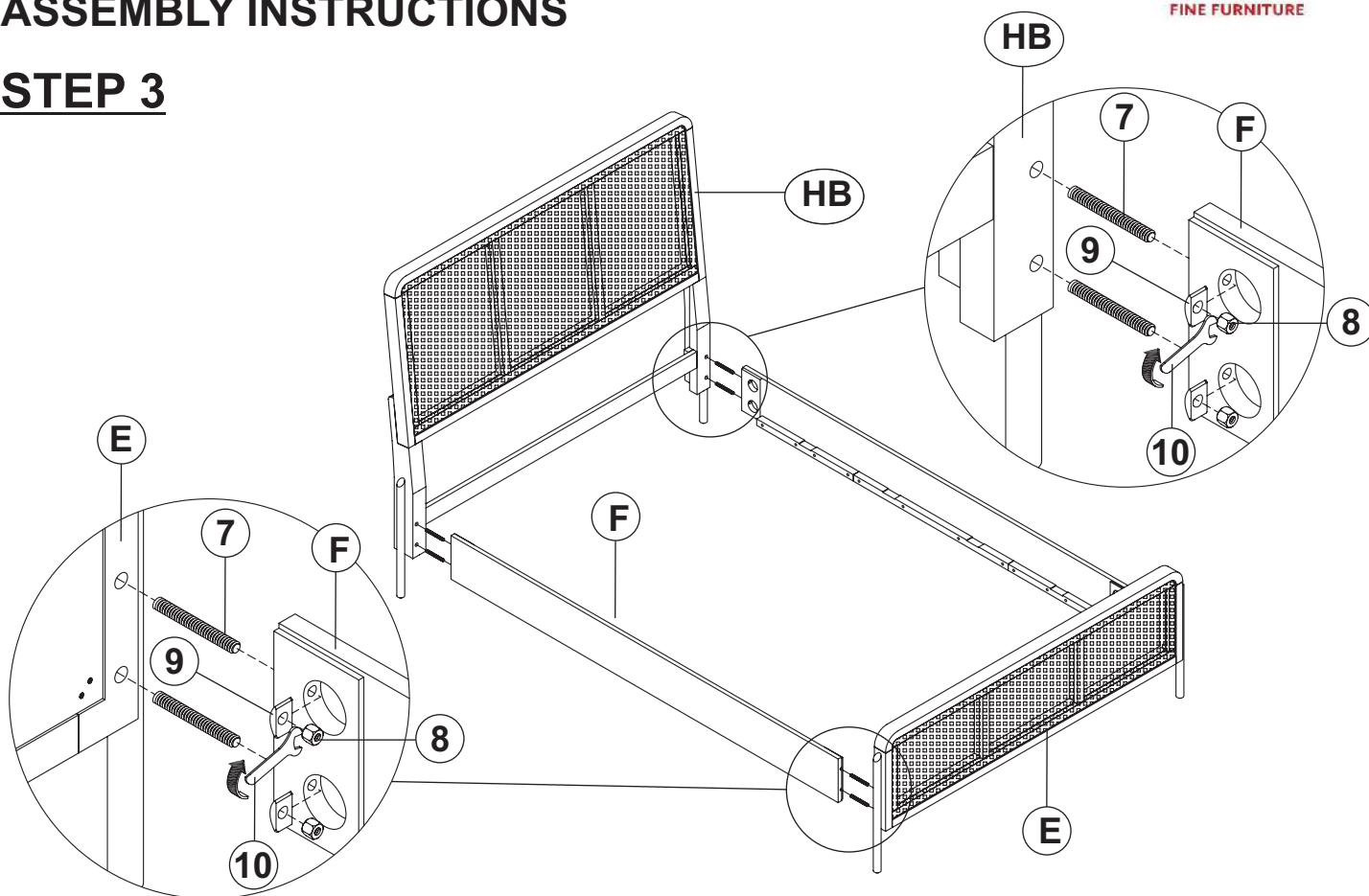

STEP 4

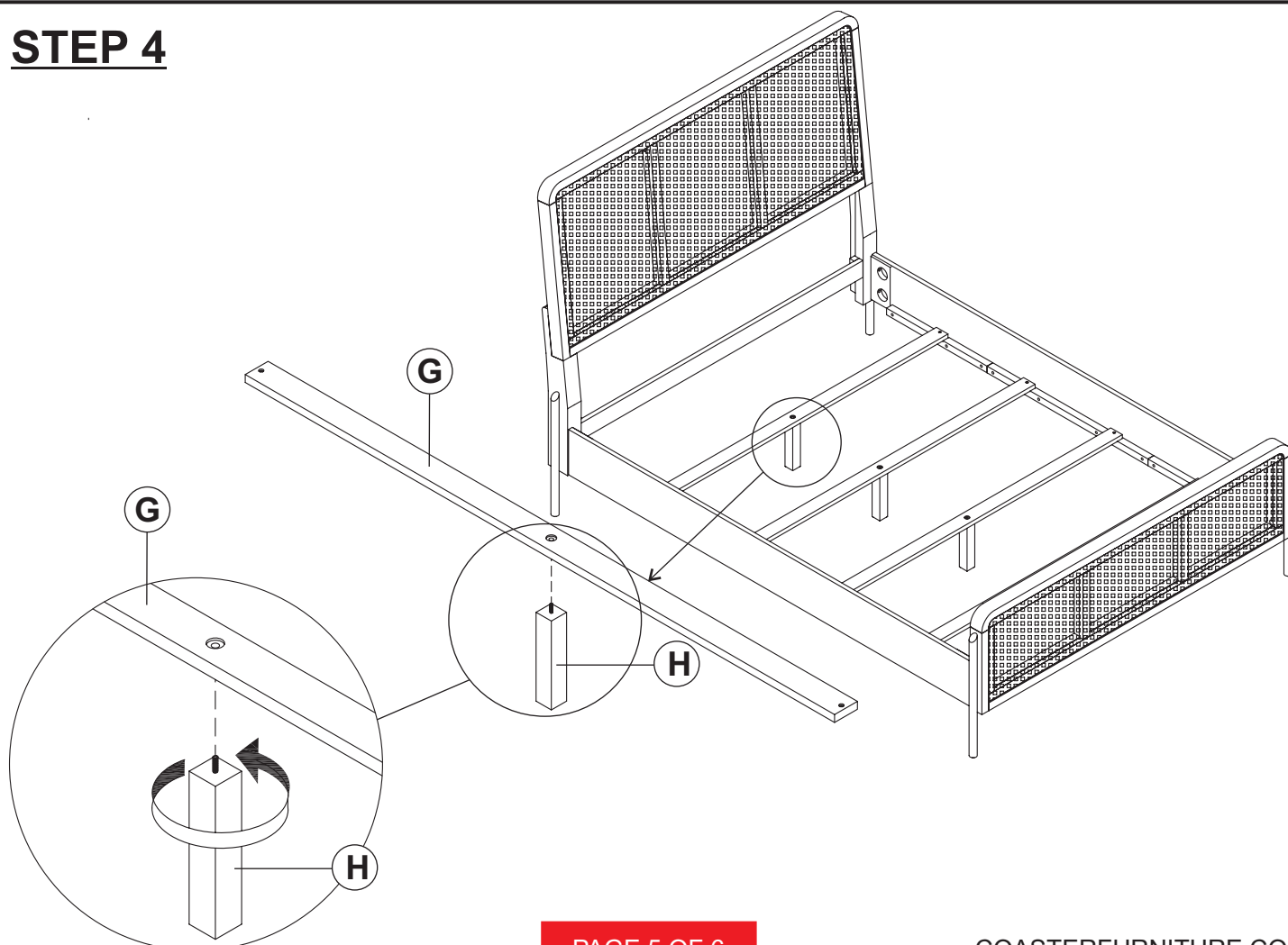

ITEM: 224300Q (B1-B3)

ASSEMBLY INSTRUCTIONS



STEP 5

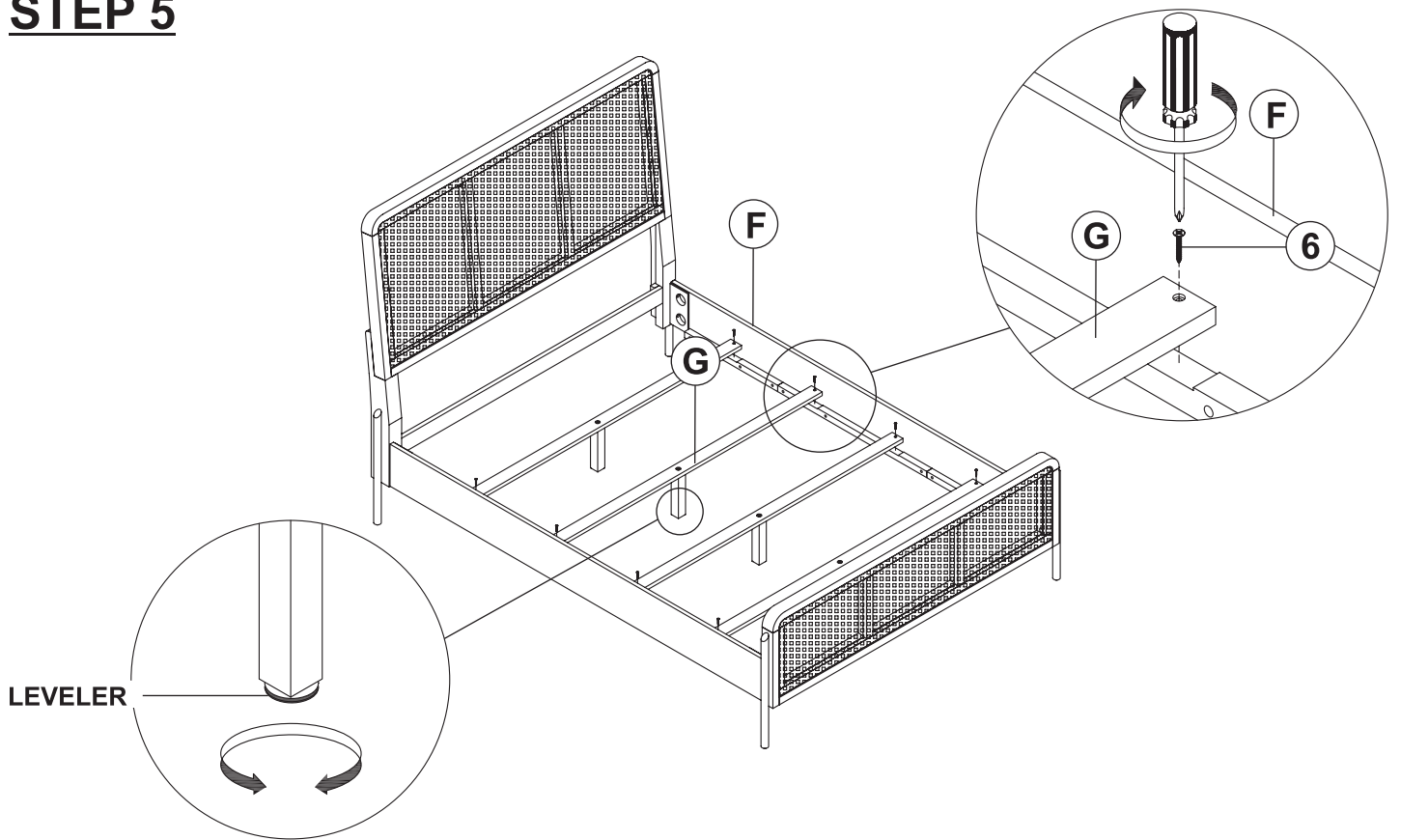

STEP 6 COMPLETE

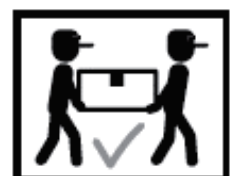
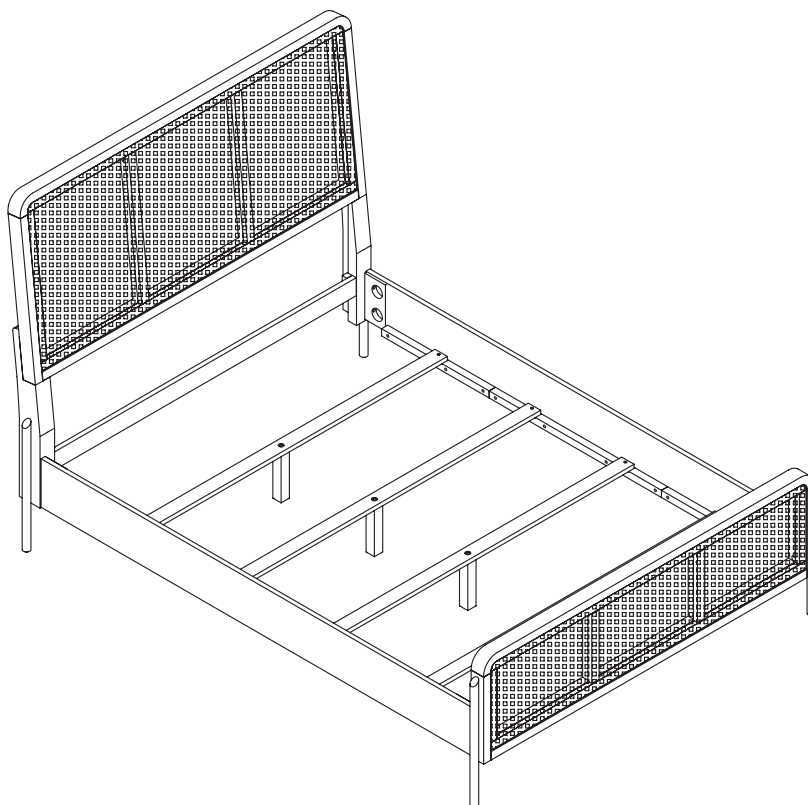

ITEM: 224300Q (B1-B3)

Inner Size : 61.00"W x 82.00"D

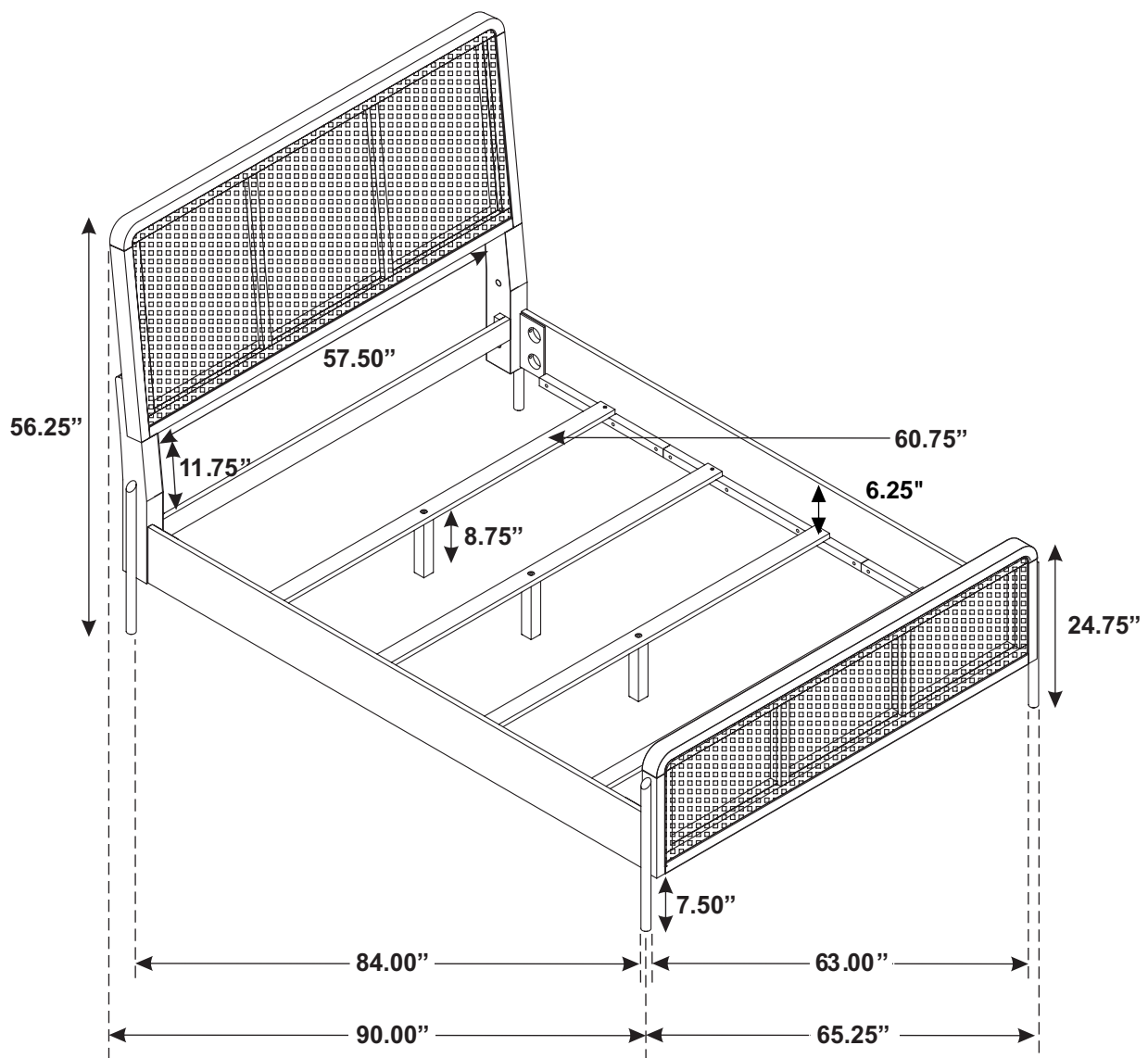

Note: Dimension tolerance $\pm 5\%$