

Assembly Instructions

Caution: You Must read this before you proceed.

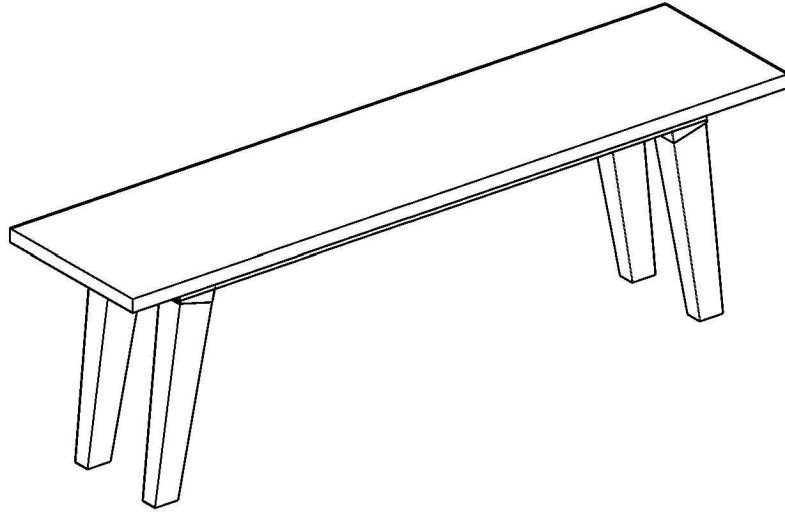

Bench

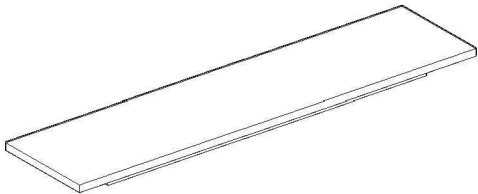
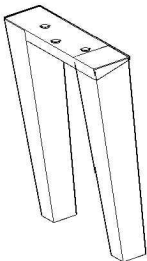
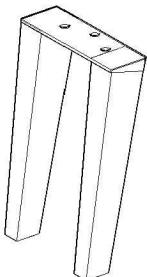

Parts List

Lable	Picture	Description	QTY
A		Top	1
B		Right Leg	1
C		Left Leg	1

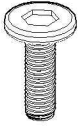
Hardware

Label	Picture	Description	QTY
①		Allen Bolt(6x15mm)	7
②		Washer(8x20mm)	7
③		Allen Key	1

Assembly Preparation

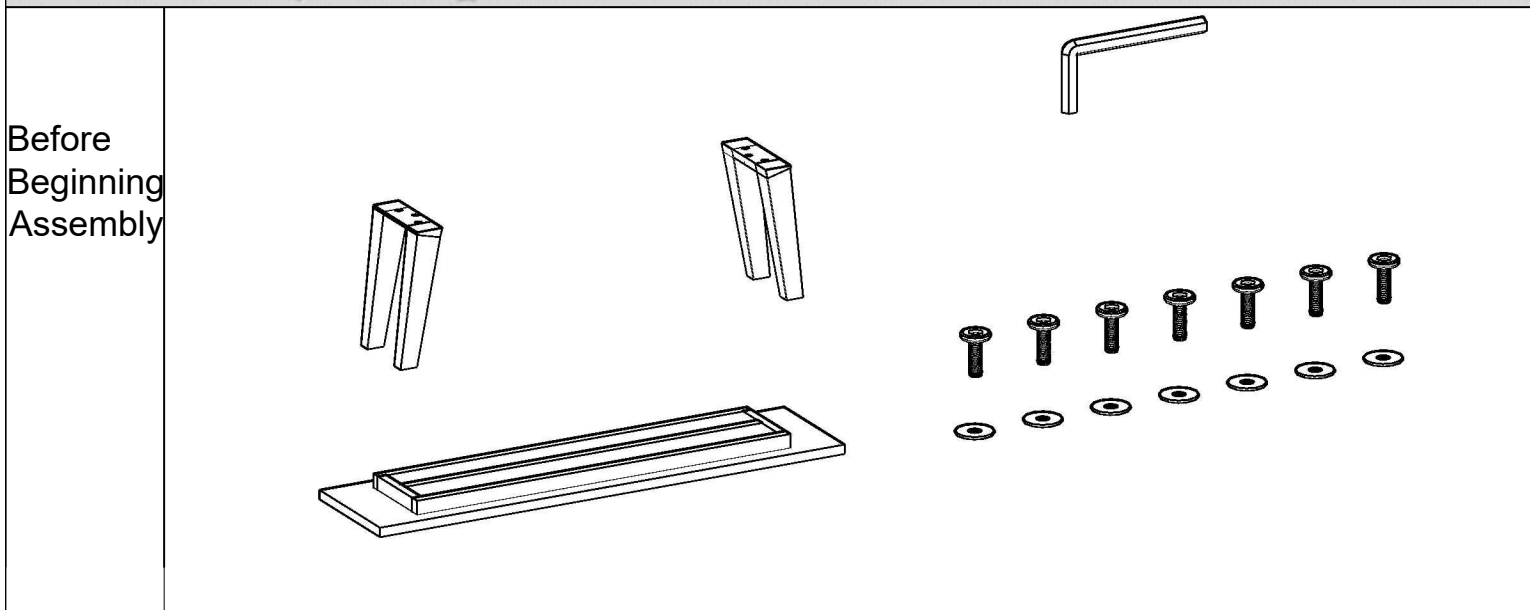

- Read instructions, cover to cover-



- Have 2 adults on hand for assembly-



- Do not assemble on flooring or carpet-



- Assemble on a clean non-marring surface (packing foam)-



- Save all packaging until finished-

Assembly Steps

Overview

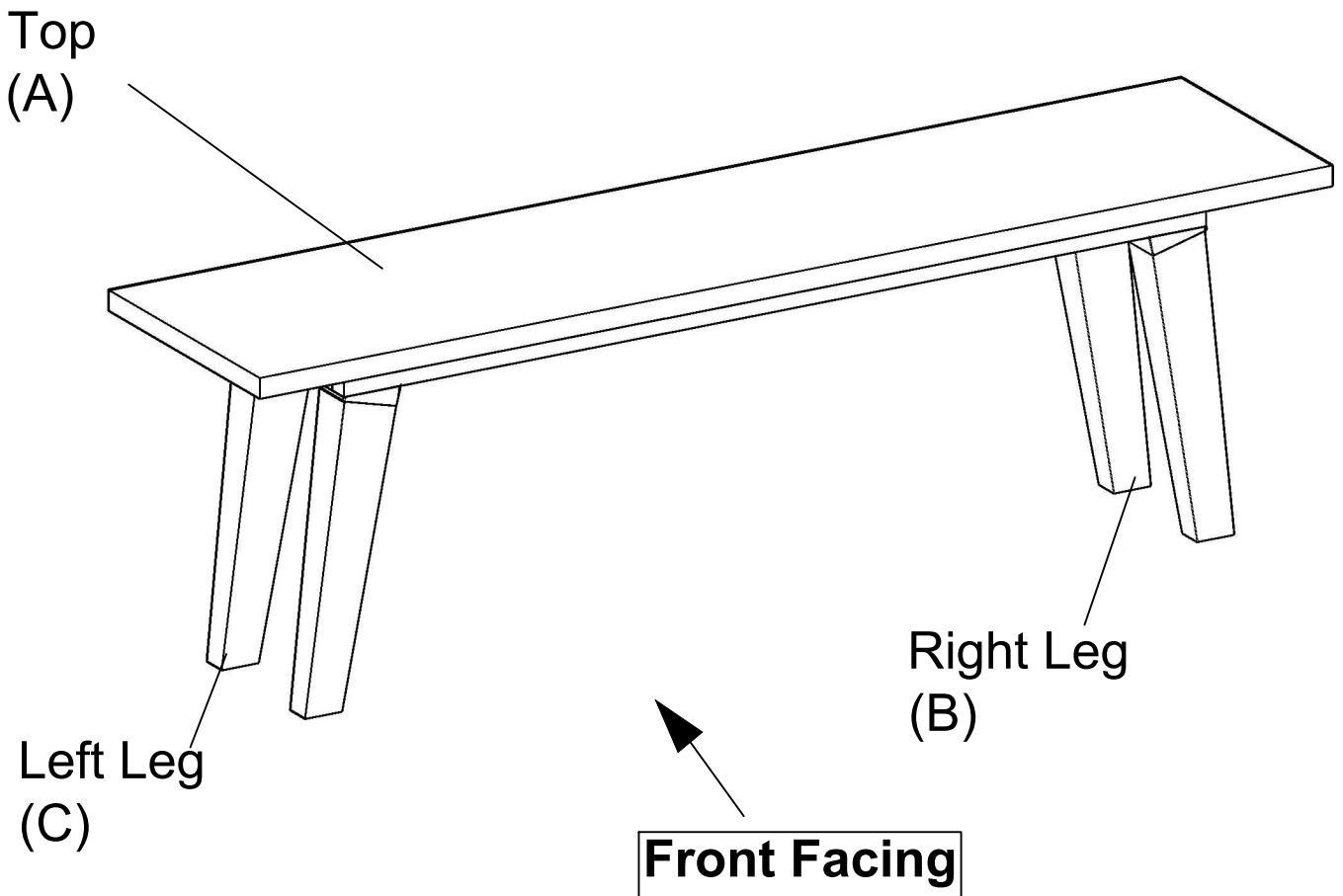

This Bench has multiple parts and may require up to some 30 minutes to assemble. To give you an overview of the Bench parts, the above picture is to help you put the various parts into perspective. Please read through the instructions below to familiarise yourself with the parts and steps before assembly.

Step 1

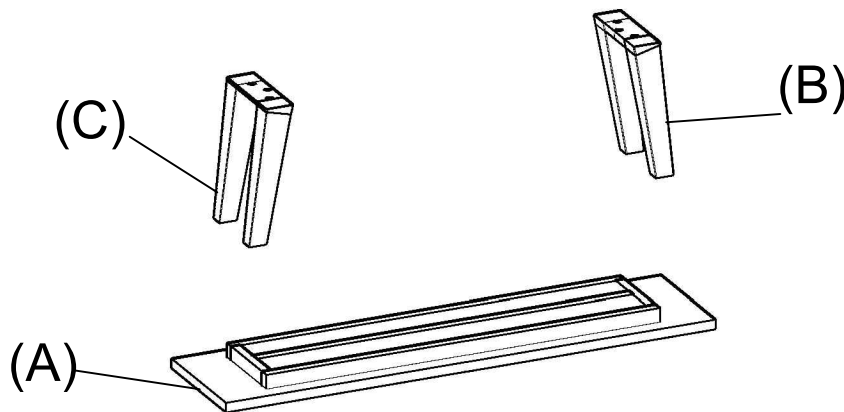

Unpack and place all parts on a clean, non-marring surface.

Step 2

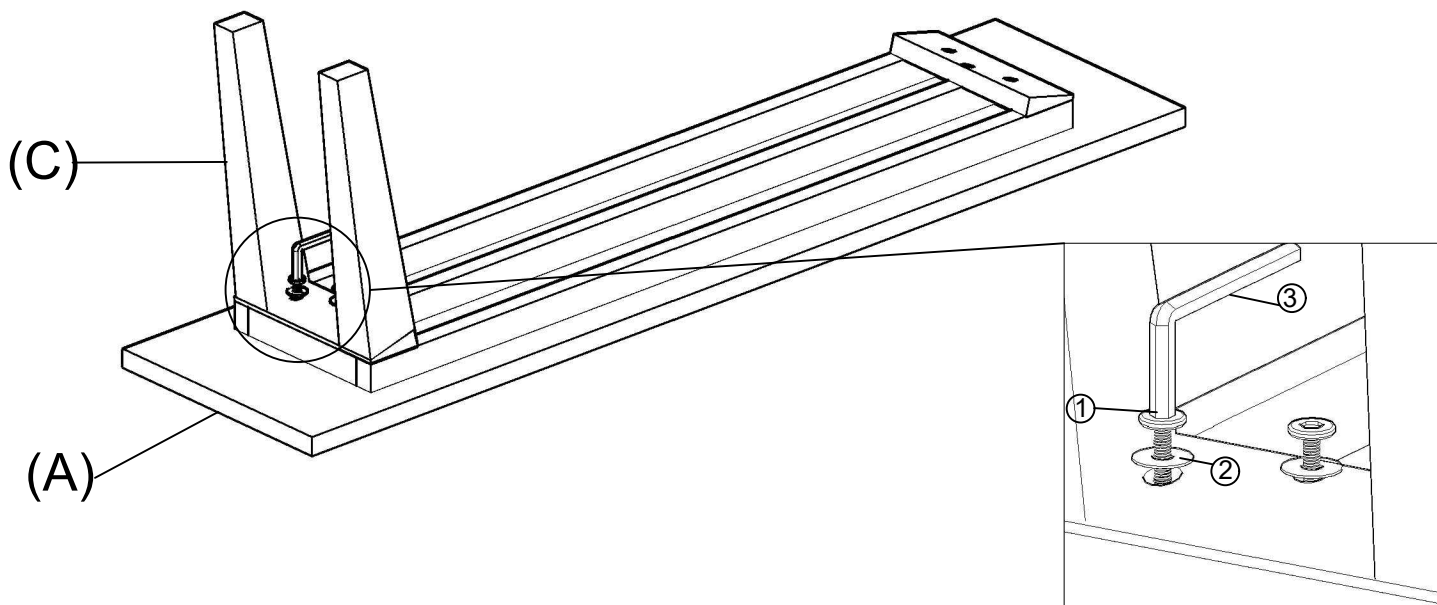

Place the Top (A) with top side face skywards onto a clean, soft surface to avoid any scratches or damages to the product. Align the Left Leg(C) with connector screw hole in Top(A) as shown above.

Then, affix the Left leg (C) with Top (A) by using Allen Bolt(①), Washers(②) & Allen Key(③).

DO NOT FULLY TIGHTEN BOLTS.

Step 3

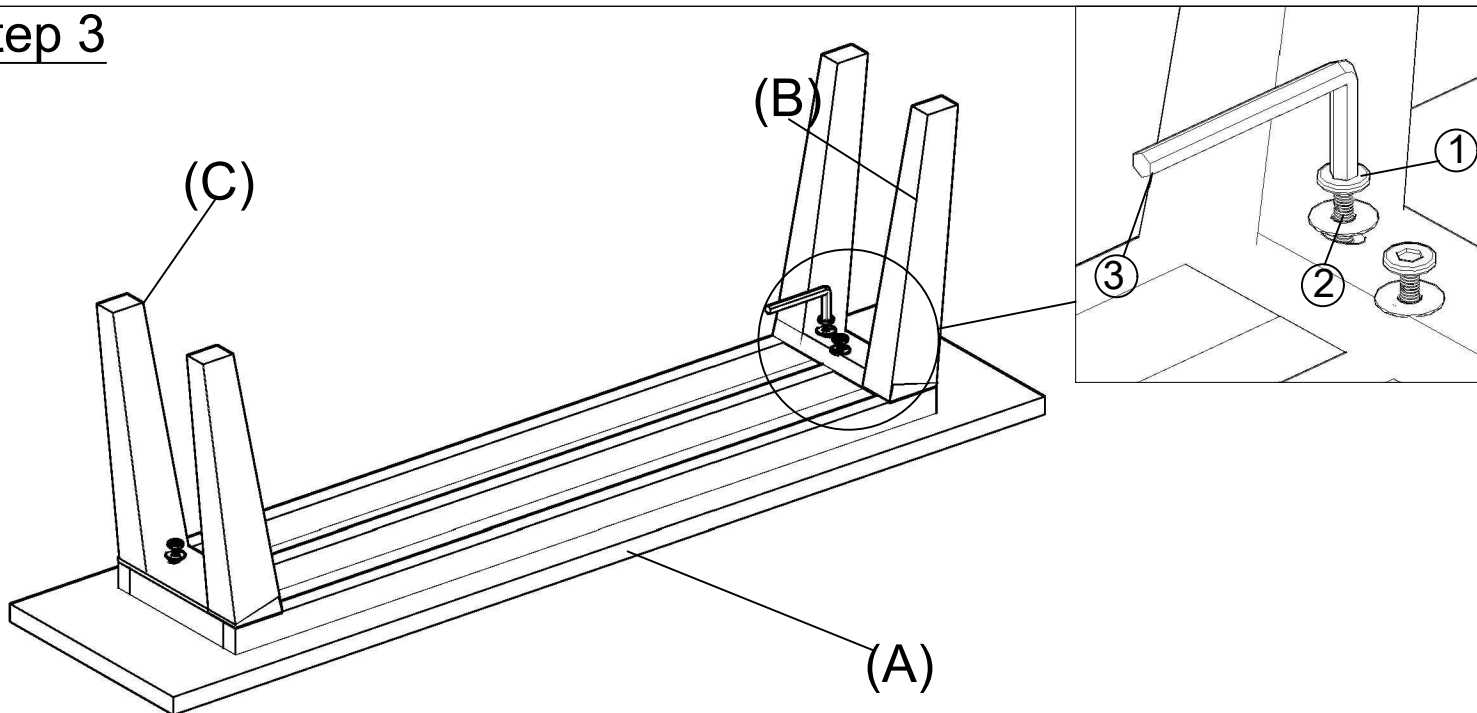

Repeat the above process with second Right Leg (B) and fully tighten the bolts.

Step 4

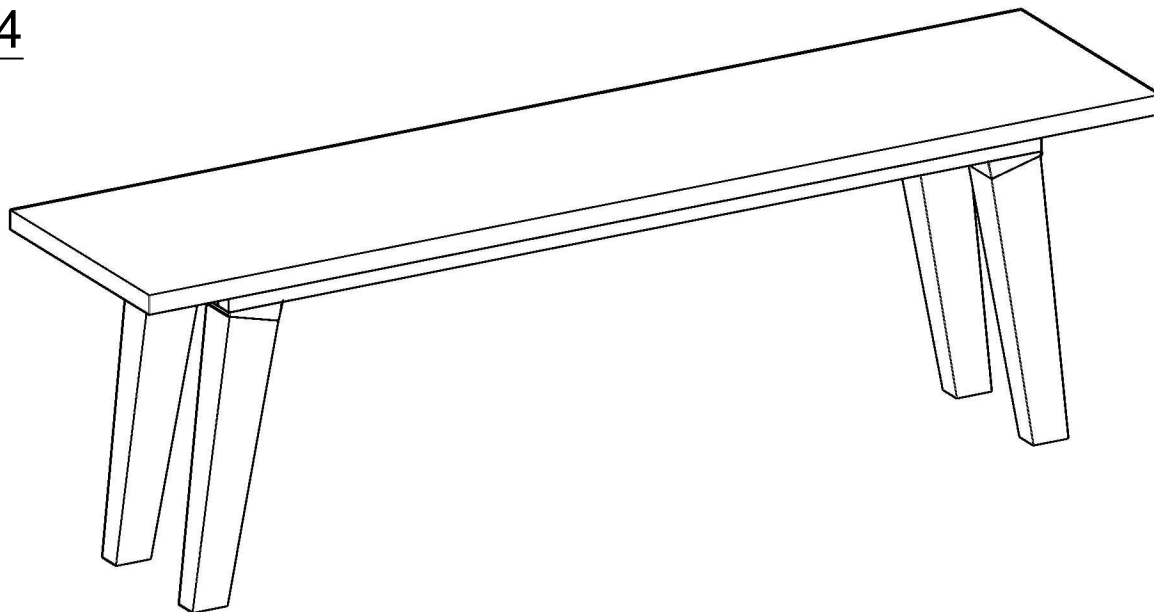

Turn the Bench right side up
Place the Bench on a LEVEL SURFACE.
This Bench is now ready to use.

CAUTION 1: When tightening these bolts, tighten sequentially. DO NOT tighten any bolt fully and then towards the next one. This would cause the frame to warp. If there is still wobbles, loosen the bolts and execute this same process.

Care & Maintenance



- Furniture may scratch floors. We recommend using furniture pads to protect your floors.



- Do not put hot items directly on furniture surface.



- Do not clean furniture with harsh cleansers or polish.



- Do not place furniture under direct sunlight.



- Do not place furniture near heating or cooling vents.



- Do not write on furniture without a padded barrier to protect the surface.



- Do not place furniture outside . For indoor use only.



- Not for commercial use. For residential use only.



- Stains may be removed with mild soap solution and damp cloth.



- Children should not climb or jump on the furniture.



- Dust and pick-up spills using a clean, non-colored, lint-free cloth.