

Instruction Manual

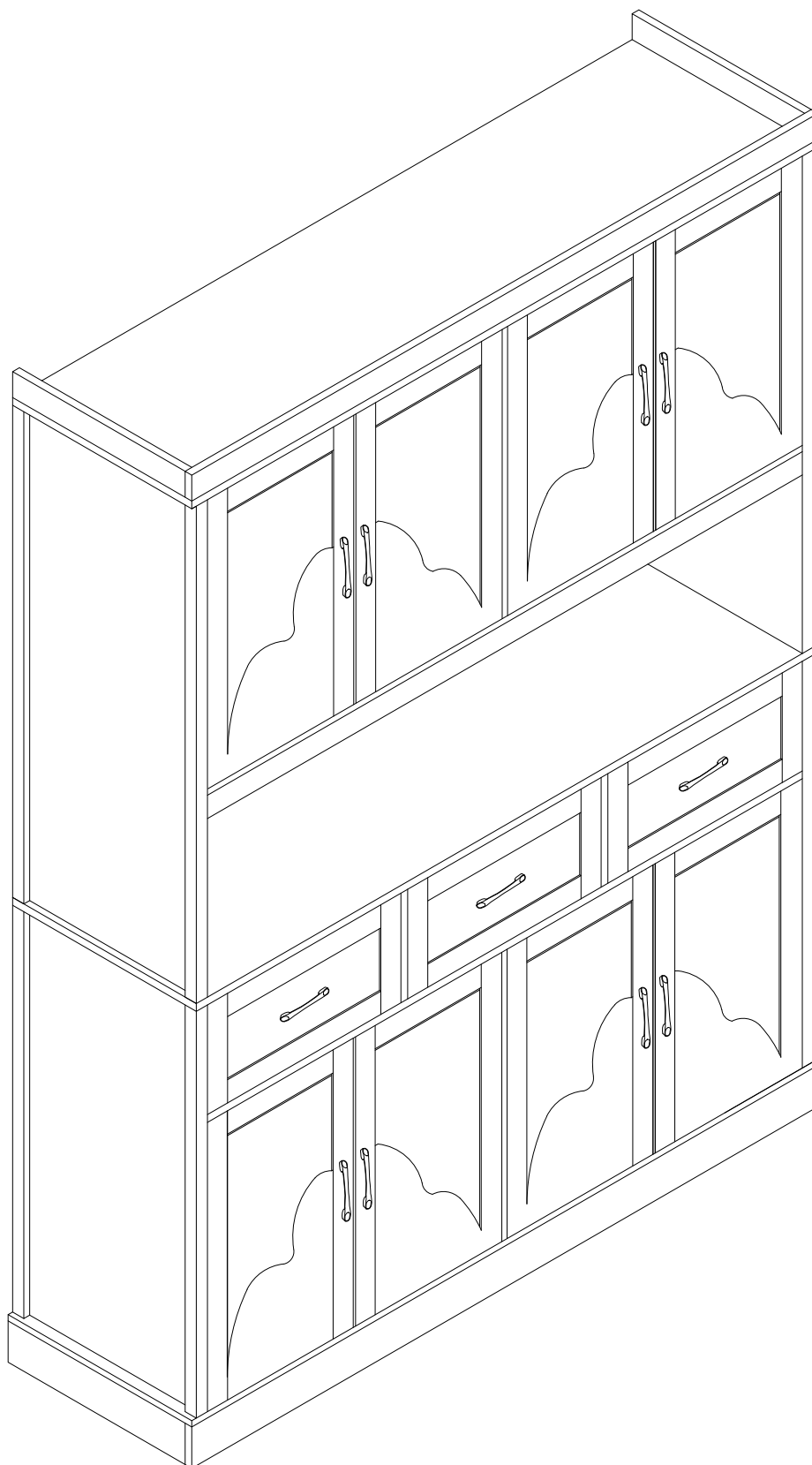

Tall Cabinet

EN

Thank you for purchase on our products. Please contact us if you have difficulty with assembly or need replacement parts. Our customer service is here to assist you. Please attach your User Name or Order ID so that we can assist you better.

WARNING

Serious or fatal injury may occur from unexpected assembly or use.

1. During the assembly process, keep all parts away from babies or children.
2. Always securely fix this product to the wall. Make sure the wall area to be drilled is free from hidden electrical wires, water and gas pipes.
3. Use of tip-over restraints may only reduce, but not eliminate the risk of tip-over.
4. Unless specially designed to accommodate, do not set heavy objects on top of this product.
5. Place the heaviest items on the lowest shelf.
6. Never allow children to climb or bang on drawers, doors or shelves.

DE

Vielen Dank für Ihren Kauf von uns Produkten. Bitte kontaktieren Sie uns, wenn Sie Probleme mit Montage haben oder Ersatzteile benötigen. Wir Kundenservice ist für Sie da. Bitte geben Sie Ihren Benutzernamen oder Ihre Bestellnummer an, damit wir Sie besser unterstützen können.

WARNUNG

Bei unerwarteter Montage oder Verwendung können schwere oder tödliche Verletzung auftreten.

1. Legen Sie in den Montageprozess alle Teile weg von Babys oder Kindern.
2. Stellen Sie sicher, dass der gebohrte Wandbereich frei von verborgenen Stromkabeln, Wasser- und Gasleitungen ist, wenn Sie dieses Produkt an der Wand befestigen.
3. Die Verwendung von Kippsicherungen kann die Gefahr eines Kippens nur verringern, jedoch nicht beseitigen.
4. Setzen Sie bitte keine schweren Gegenstände auf dieses Produkt, es sei denn, dass das Produkt speziell für die Unterbringung konzipiert wird.
5. Legen Sie bitte die schwersten Gegenstände auf das unterste Regal.
6. Erlauben Sie nie Kindern, auf Schubladen, Türen oder Regale zu klettern oder zu knallen.



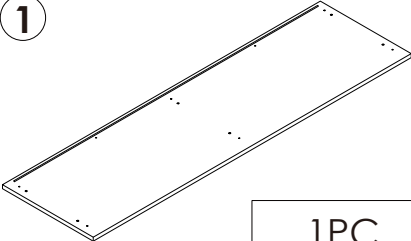
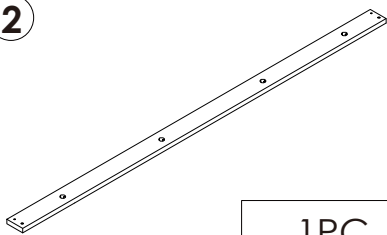
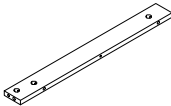
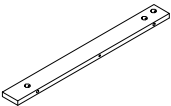
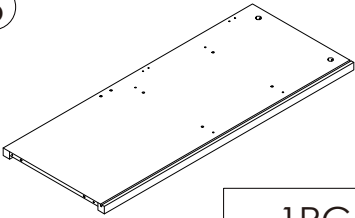
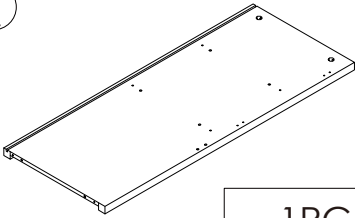
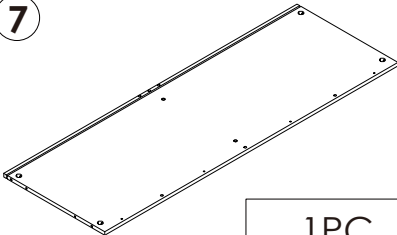
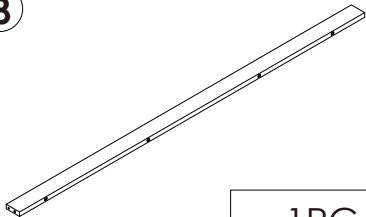
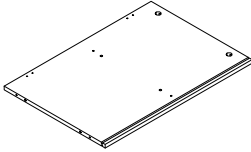
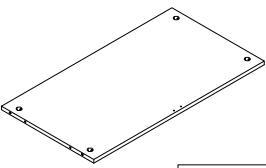
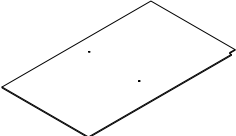
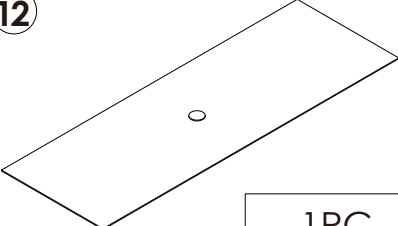
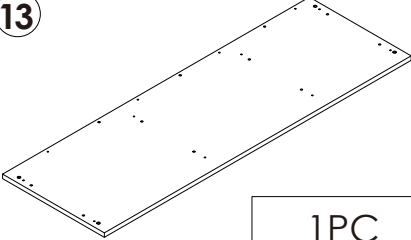
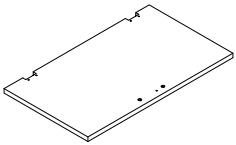
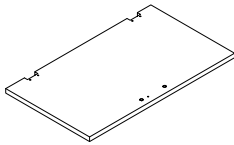
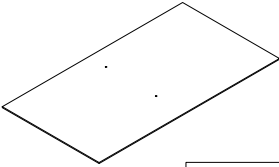
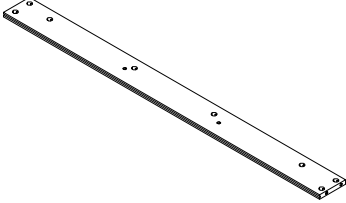
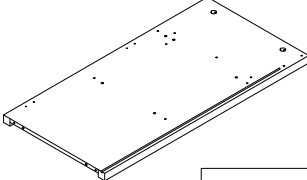
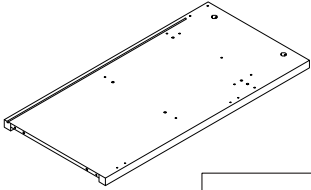
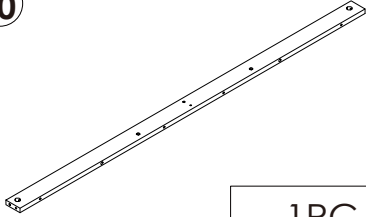
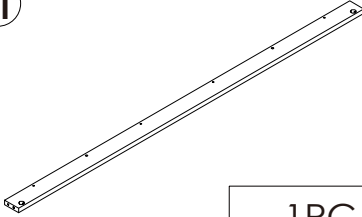



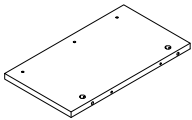
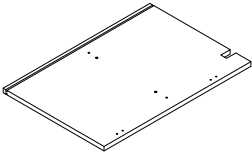
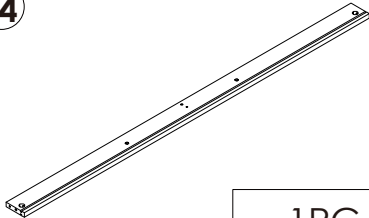
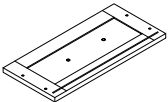
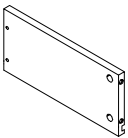
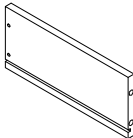
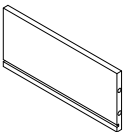
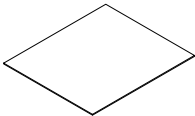
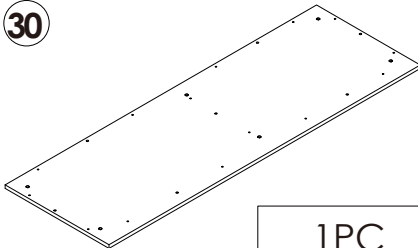
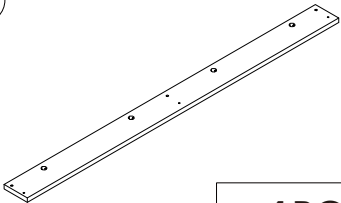
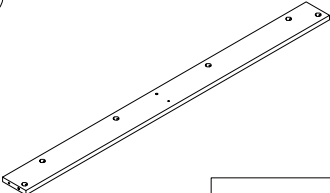
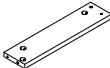
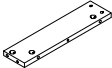
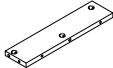
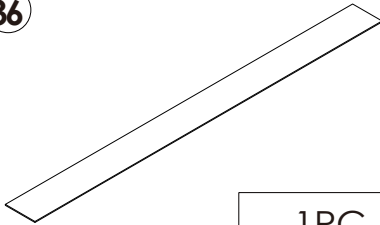
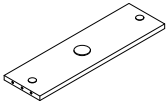

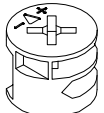

Parts List(EN) / Teile Liste(DE)

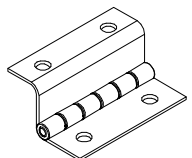
<p>①</p>  <p>1PC</p>	<p>②</p>  <p>1PC</p>	<p>③</p>  <p>1PC</p>
<p>④</p>  <p>1PC</p>	<p>⑤</p>  <p>1PC</p>	<p>⑥</p>  <p>1PC</p>
<p>⑦</p>  <p>1PC</p>	<p>⑧</p>  <p>1PC</p>	<p>⑨</p>  <p>1PC</p>
<p>⑩</p>  <p>4PCS</p>	<p>⑪</p>  <p>4PCS</p>	<p>⑫</p>  <p>1PC</p>
<p>⑬</p>  <p>1PC</p>	<p>⑭</p>  <p>4PCS</p>	<p>⑮</p>  <p>4PCS</p>
<p>⑯</p>  <p>4PCS</p>	<p>⑰</p>  <p>1PC</p>	<p>⑱</p>  <p>1PC</p>
<p>⑲</p>  <p>1PC</p>	<p>⑳</p>  <p>1PC</p>	<p>㉑</p>  <p>1PC</p>

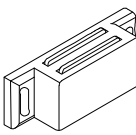
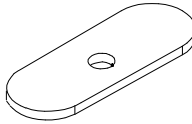
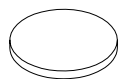
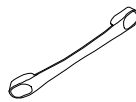
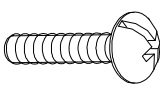
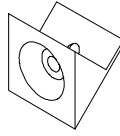
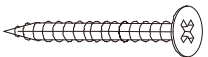
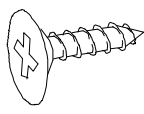
Parts List(EN) / Teile Liste(DE)

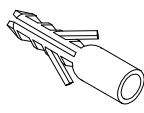
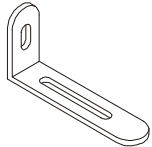
<p>22</p>  <p style="text-align: right; border: 1px solid black; padding: 2px;">2PCS</p>	<p>23</p>  <p style="text-align: right; border: 1px solid black; padding: 2px;">1PC</p>	<p>24</p>  <p style="text-align: right; border: 1px solid black; padding: 2px;">1PC</p>
<p>25</p>  <p style="text-align: right; border: 1px solid black; padding: 2px;">3PCS</p>	<p>26</p>  <p style="text-align: right; border: 1px solid black; padding: 2px;">3PCS</p>	<p>27</p>  <p style="text-align: right; border: 1px solid black; padding: 2px;">3PCS</p>
<p>28</p>  <p style="text-align: right; border: 1px solid black; padding: 2px;">3PCS</p>	<p>29</p>  <p style="text-align: right; border: 1px solid black; padding: 2px;">3PCS</p>	<p>30</p>  <p style="text-align: right; border: 1px solid black; padding: 2px;">1PC</p>
<p>31</p>  <p style="text-align: right; border: 1px solid black; padding: 2px;">1PC</p>	<p>32</p>  <p style="text-align: right; border: 1px solid black; padding: 2px;">1PC</p>	<p>33</p>  <p style="text-align: right; border: 1px solid black; padding: 2px;">1PC</p>
<p>34</p>  <p style="text-align: right; border: 1px solid black; padding: 2px;">1PC</p>	<p>35</p>  <p style="text-align: right; border: 1px solid black; padding: 2px;">1PC</p>	<p>36</p>  <p style="text-align: right; border: 1px solid black; padding: 2px;">1PC</p>
<p>37</p>  <p style="text-align: right; border: 1px solid black; padding: 2px;">1PC</p>		

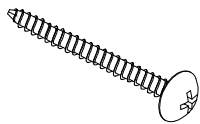
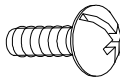
Parts List(EN) / Teile Liste(DE)

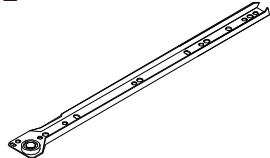
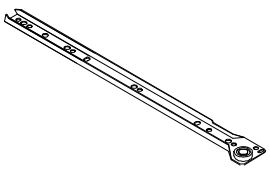
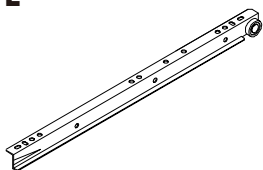
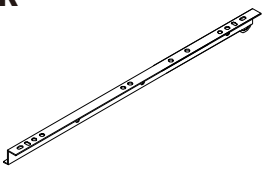
<p>A</p>  <p>M6×35mm 91+2PCS</p>	<p>B</p>  <p>∅15×10mm 91+2PCS</p>	<p>C</p>  <p>∅6×30mm 89+2PCS</p>	<p>D</p>  <p>M3×12mm 72+2PCS</p>
<p>E</p>  <p>16PCS</p>	<p>F</p>  <p>M3×14mm 34+2PCS</p>	<p>G</p>  <p>4PCS</p>	<p>H</p>  <p>8+1PCS</p>
<p>I</p>  <p>6PCS</p>	<p>J</p>  <p>11PCS</p>	<p>K</p>  <p>M4×16mm 16+2PCS</p>	<p>L</p>  <p>26+2PCS</p>
<p>M</p>  <p>M4×35mm 38+2PCS</p>	<p>N</p>  <p>M3.5×12mm 36+2PCS</p>	<p>O</p>  <p>M4×12mm 2PCS</p>	<p>P</p>  <p>L564mm 2PCS</p>
<p>Q</p>  <p>M6×30mm 2PCS</p>	<p>R</p>  <p>2PCS</p>	<p>S</p>  <p>M3×12mm 16+2PCS</p>	<p>T</p>  <p>∅6×50mm 4PCS</p>
<p>U</p>  <p>M4×45mm 4PCS</p>	<p>V</p>  <p>M4×10mm 6PCS</p>	<p>W</p>  <p>L524mm 2PCS</p>	<p>CL</p>  <p>L350mm 3PCS</p>
<p>CR</p>  <p>L350mm 3PCS</p>	<p>DL</p>  <p>L350mm 3PCS</p>	<p>DR</p>  <p>L350mm 3PCS</p>	

Assembly Steps(EN) / Montageschritte(DE)

STEP 1

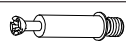
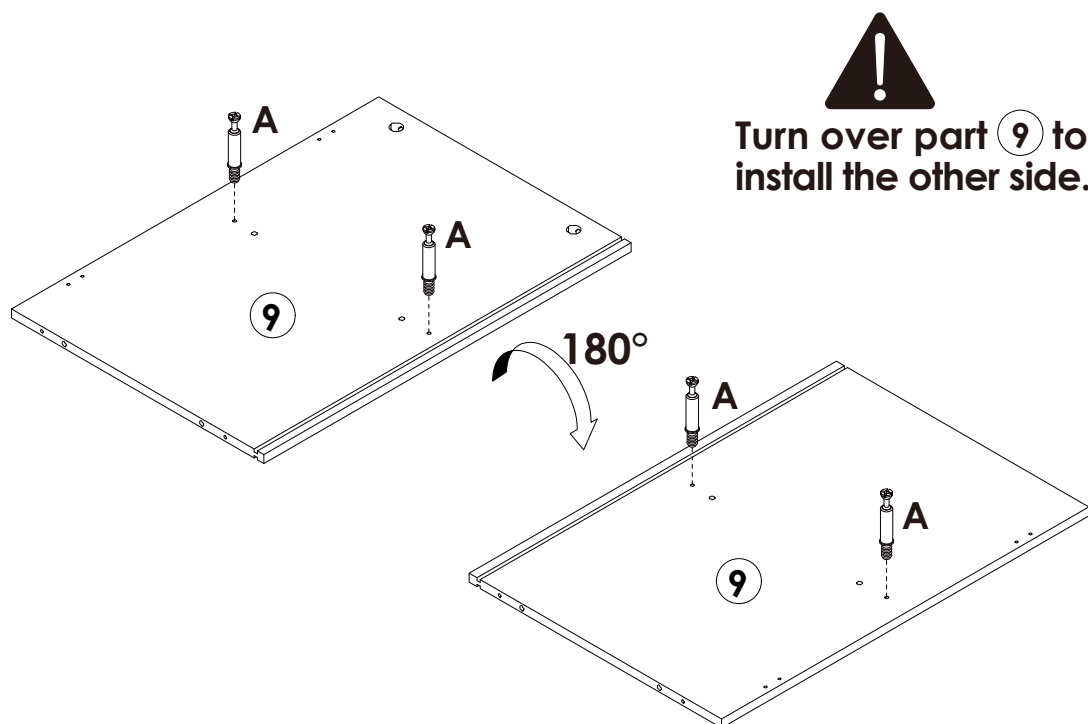

A x 4PCS

STEP 2

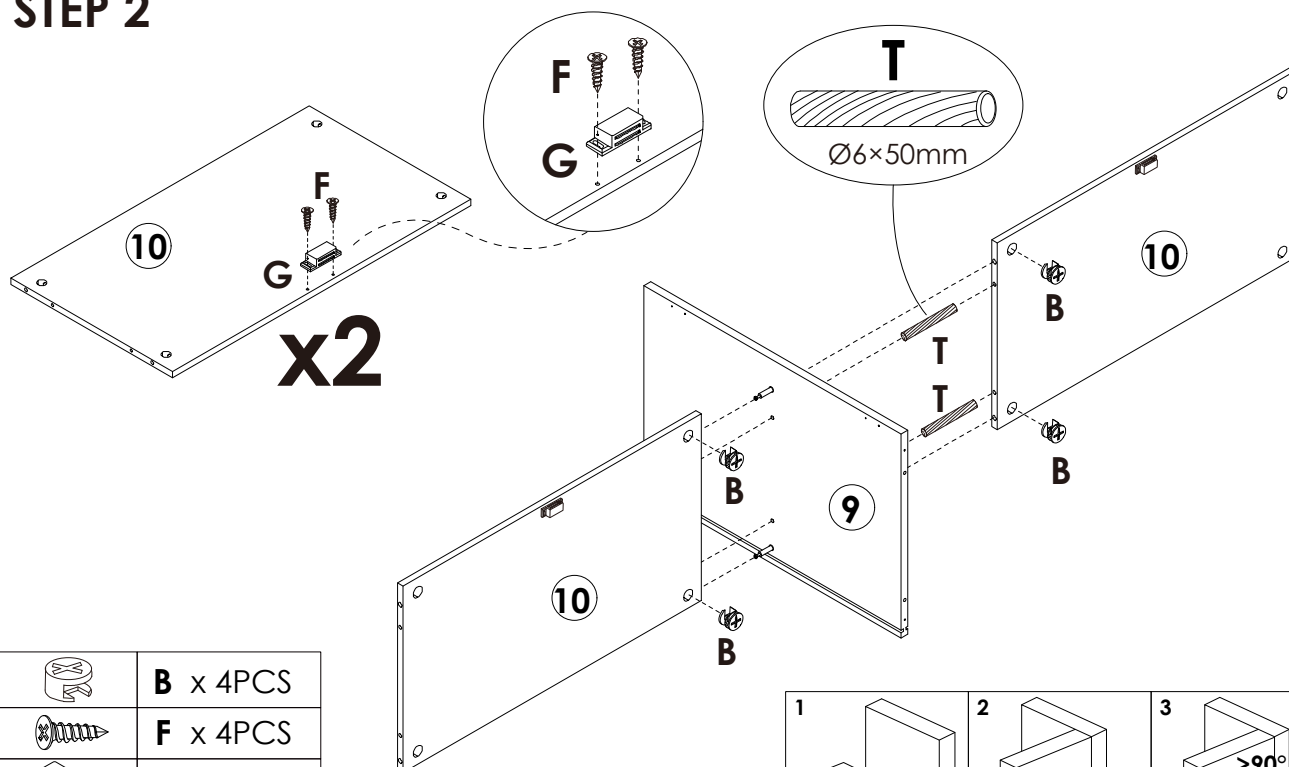

B x 4PCS



F x 4PCS



G x 2PCS



T x 2PCS

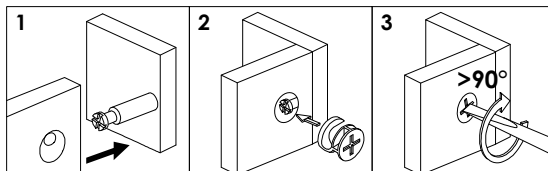

Assembly Steps(EN) / Montageschritte(DE)

STEP 3

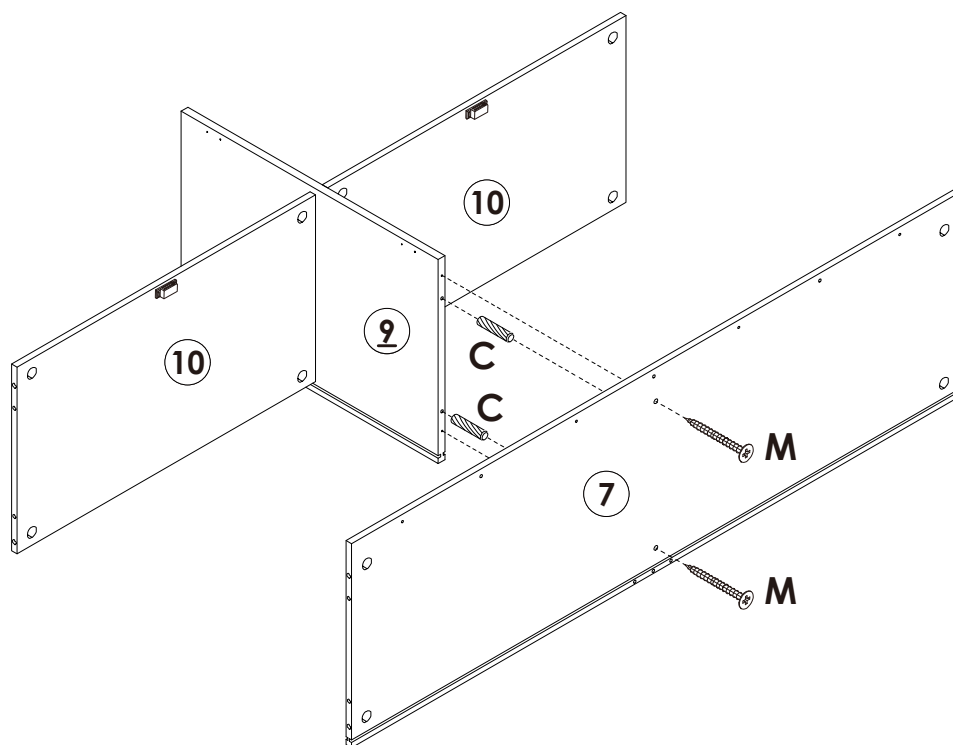

	C x 2PCS
	M x 2PCS

STEP 4

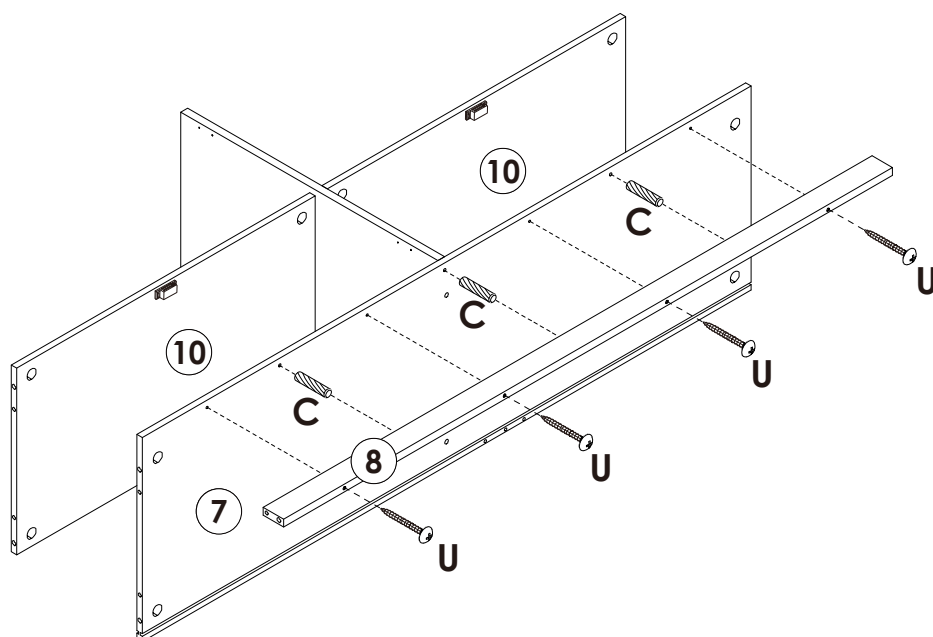

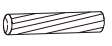
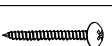
	C x 3PCS
	U x 4PCS

Assembly Steps(EN) / Montageschritte(DE)

STEP 5

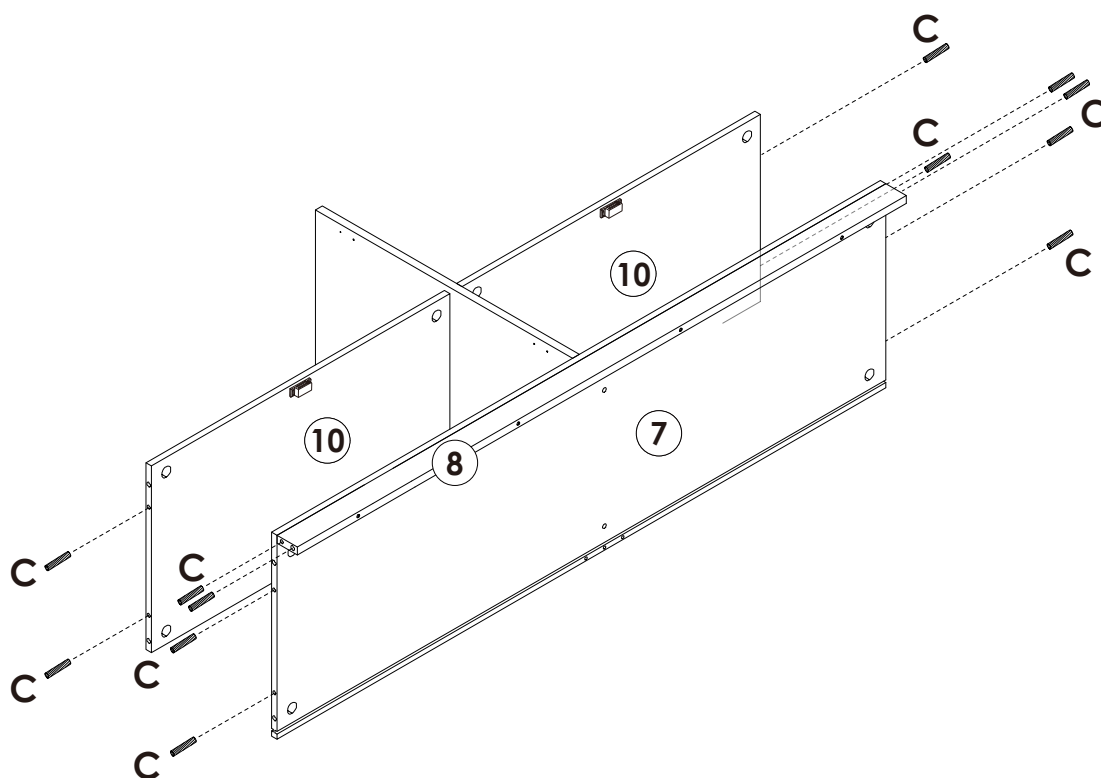

C x 12PCS

STEP 6

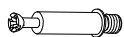
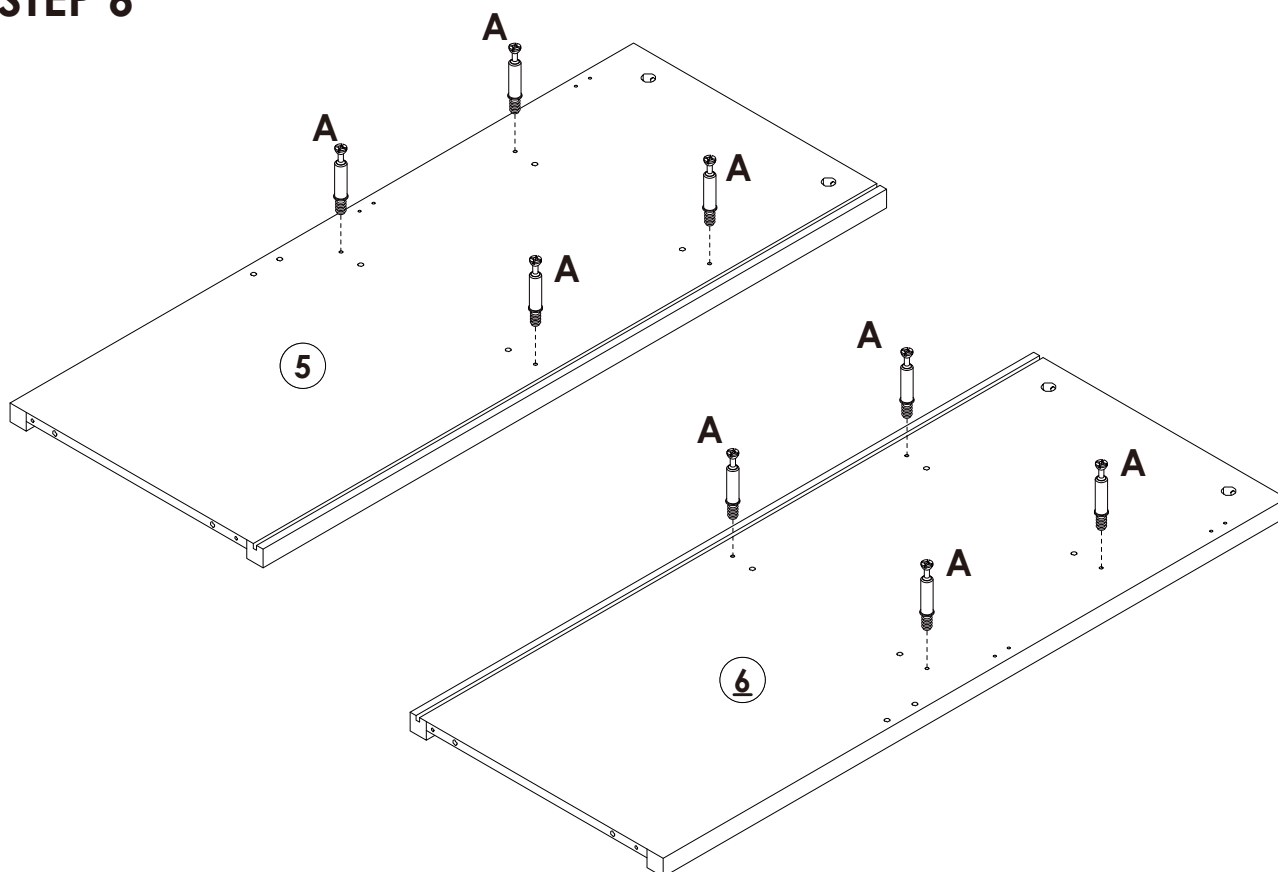

A x 8PCS

Assembly Steps(EN) / Montageschritte(DE)

STEP 7

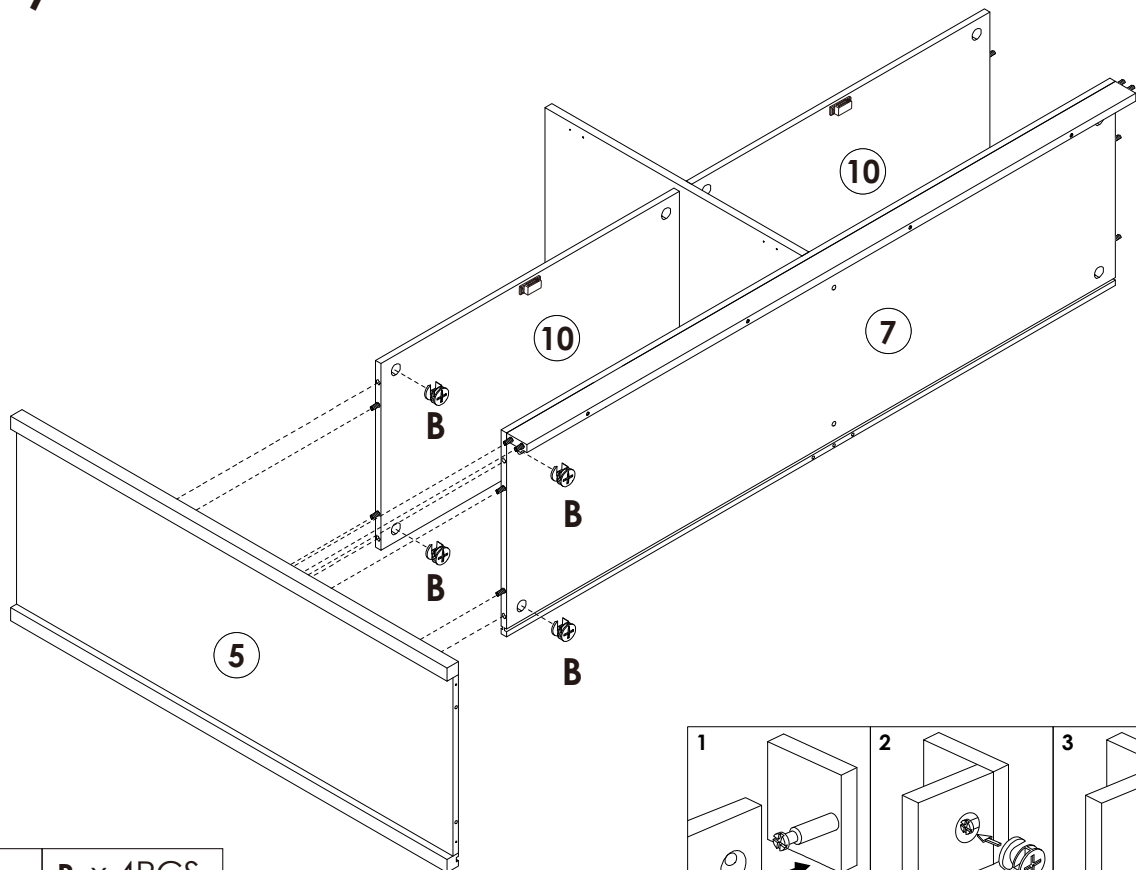

B x 4PCS

STEP 8

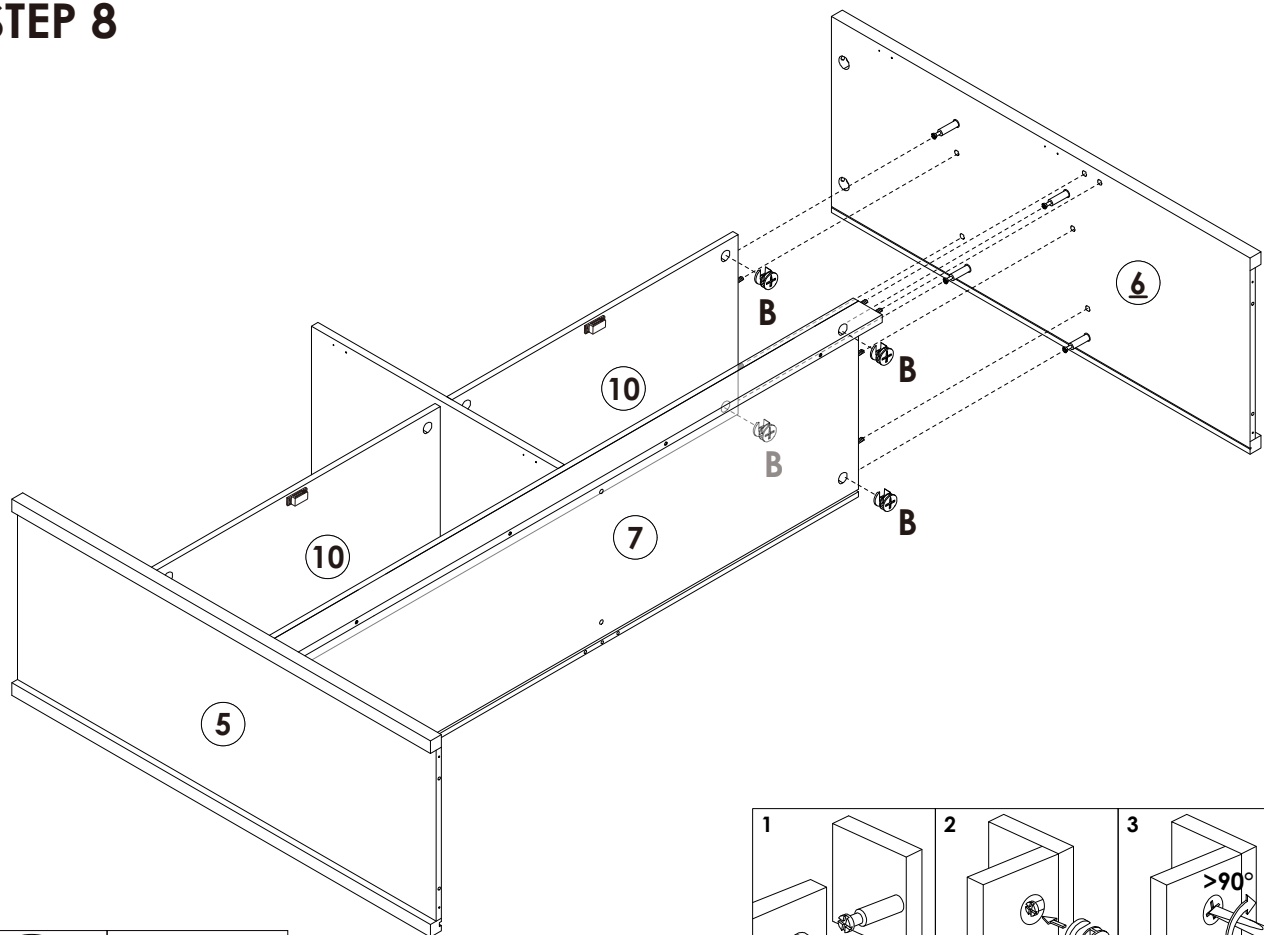

B x 4PCS

Assembly Steps(EN) / Montageschritte(DE)

STEP 9

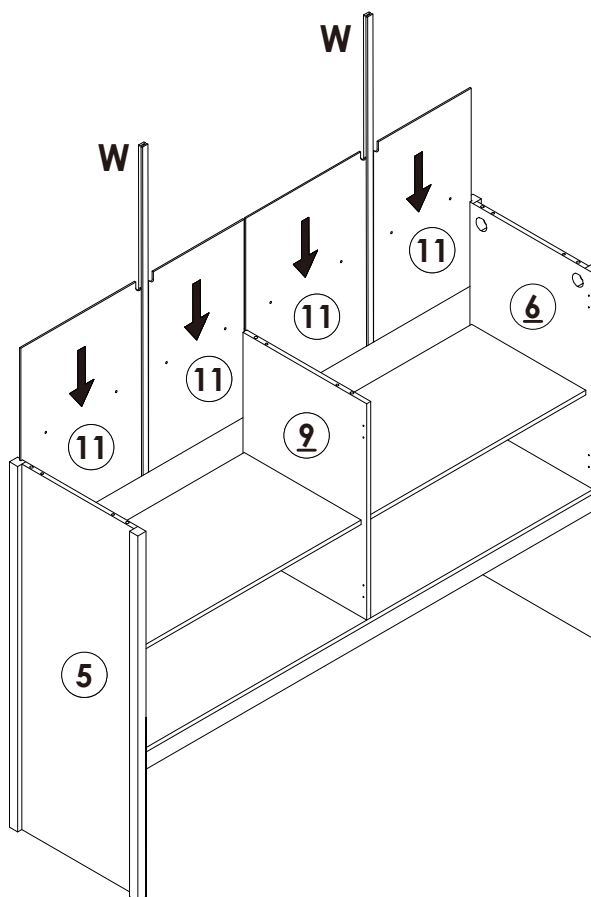
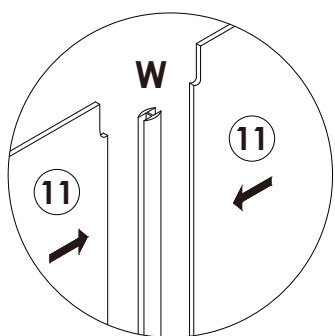

 W x 2PCS L=524mm

STEP 10

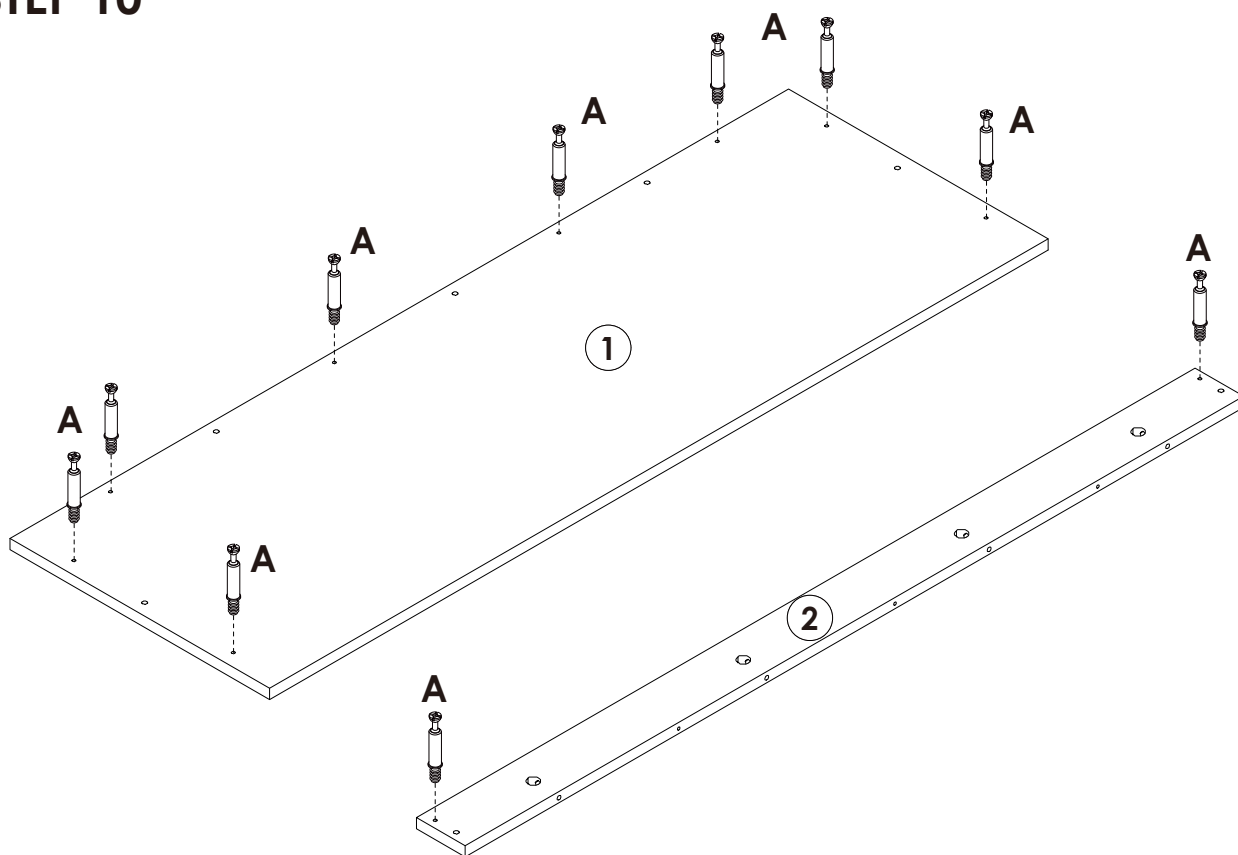



 A x 10PCS

Assembly Steps(EN) / Montageschritte(DE)

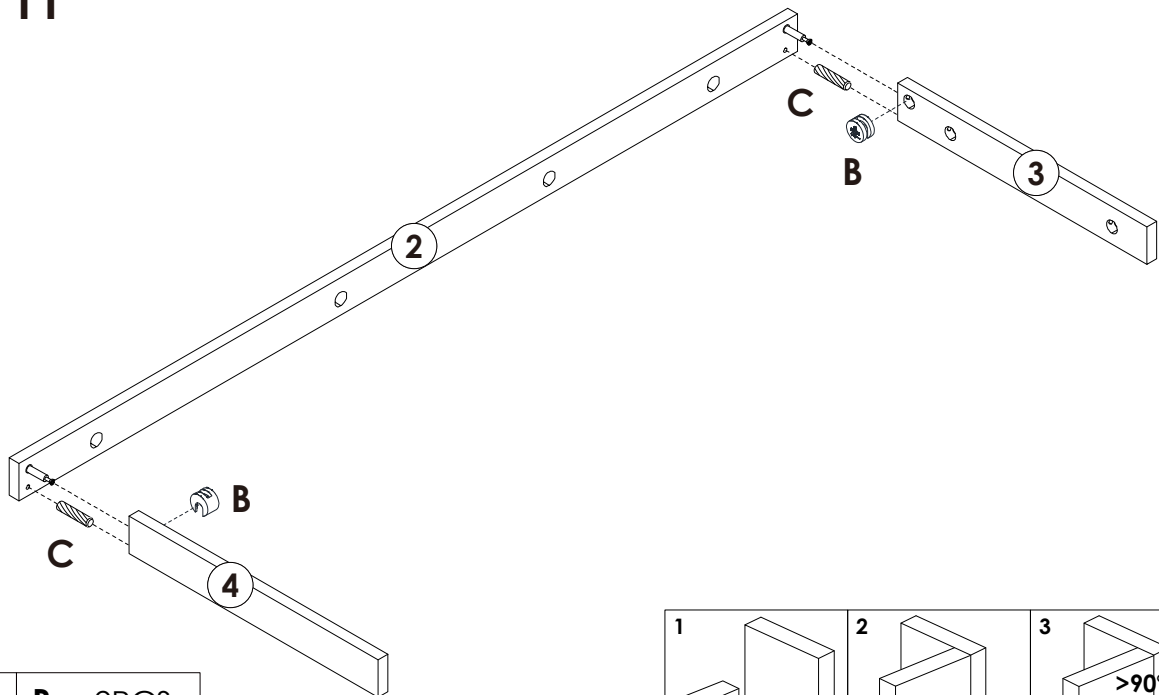
STEP 11



	B x 2PCS
	C x 2PCS

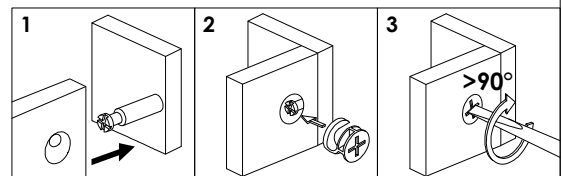

STEP 12

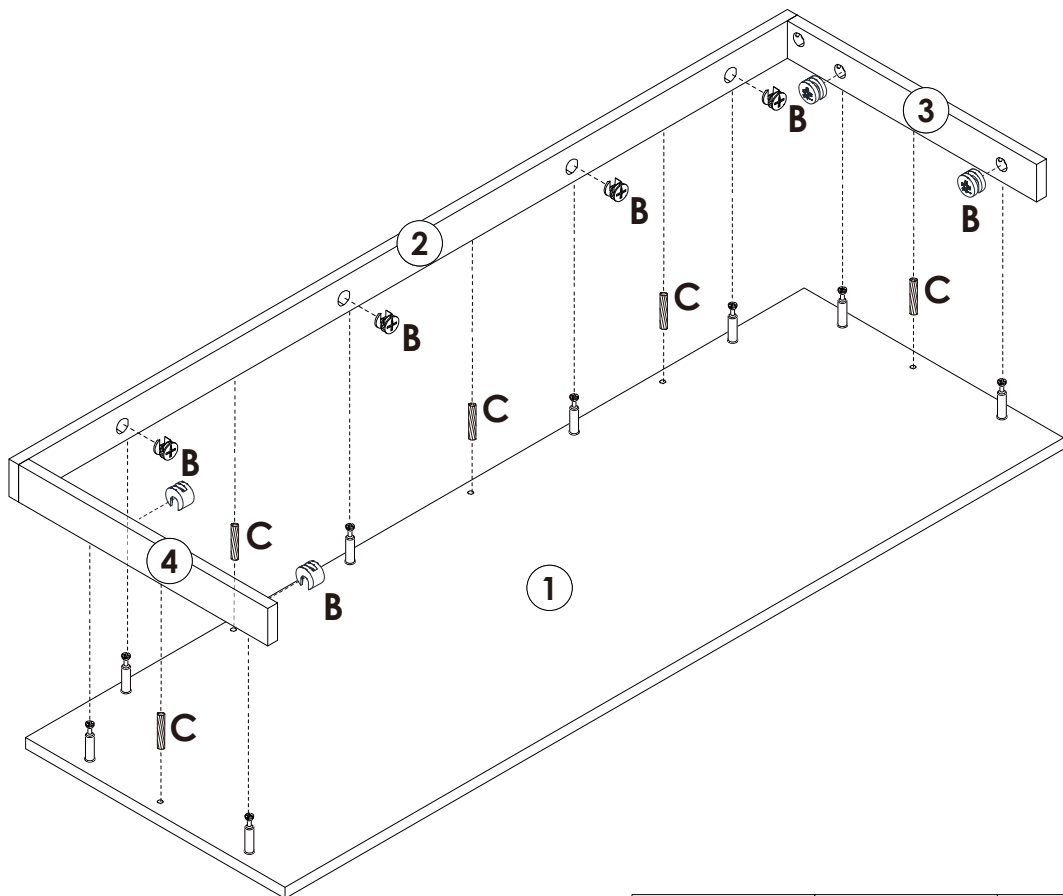

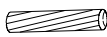

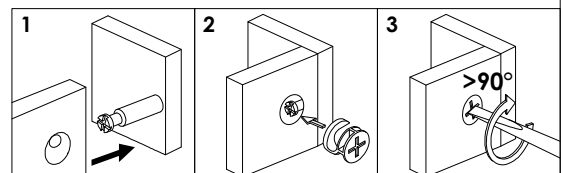
	B x 8PCS
	C x 5PCS



Assembly Steps(EN) / Montageschritte(DE)

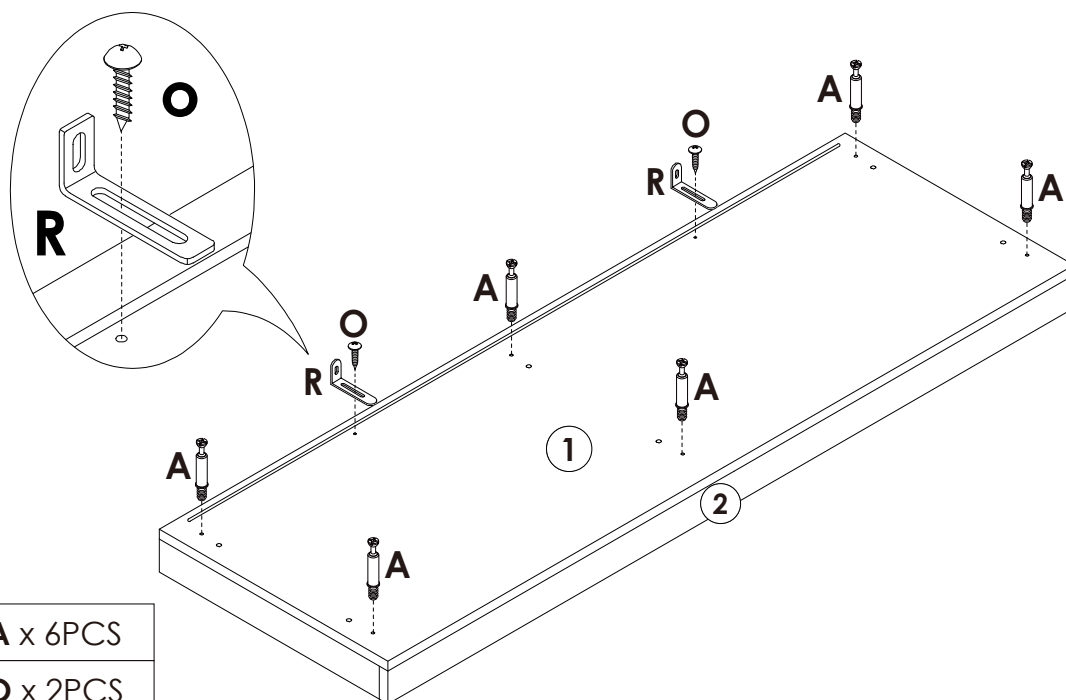

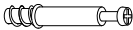
STEP 13 Lock the long side of the "R" L-shaped metal plate to the ① board with the "O" short screw

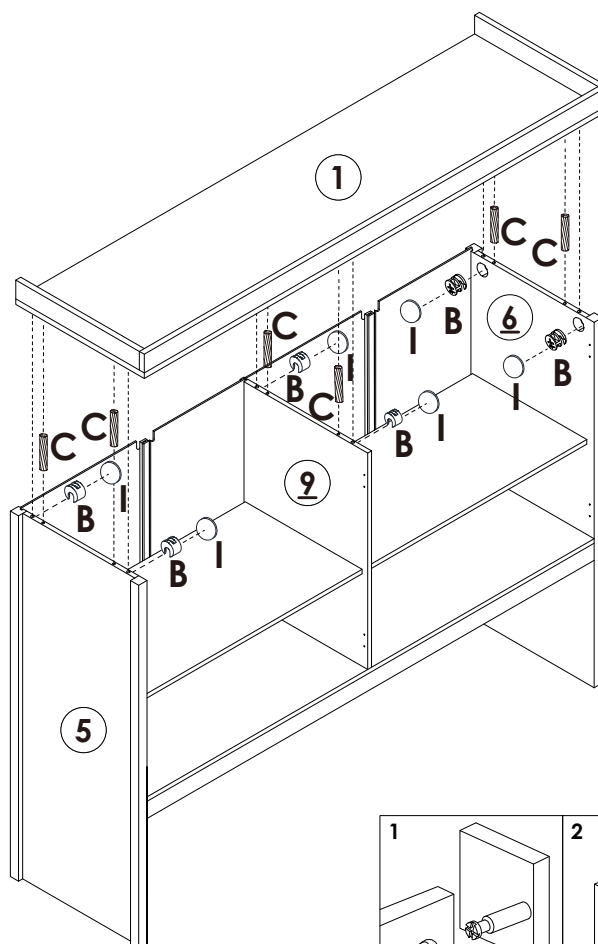
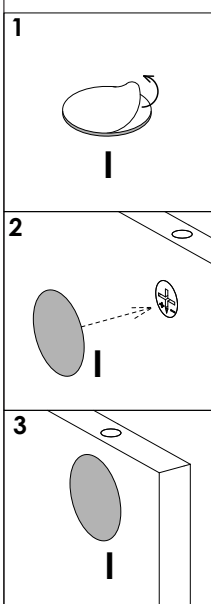

	A x 6PCS
	O x 2PCS
	R x 2PCS

STEP 14



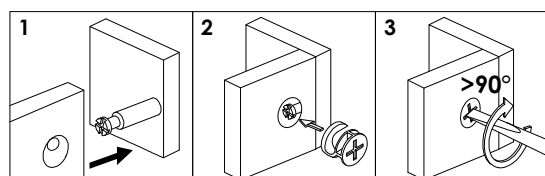

	B x 6PCS
	C x 6PCS
	I x 6PCS

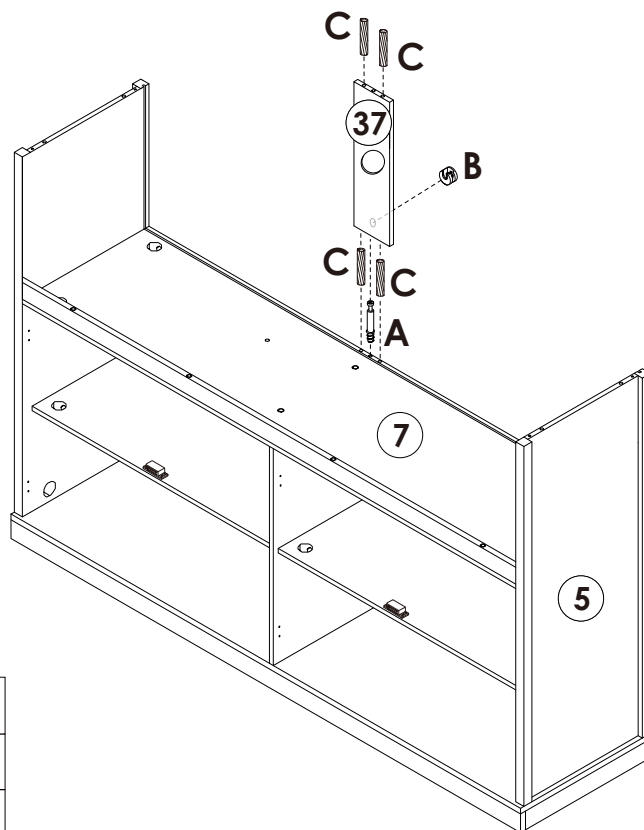

Assembly Steps(EN) / Montageschritte(DE)

STEP 15

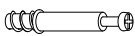

	A x 1PCS
	B x 1PCS
	C x 4PCS



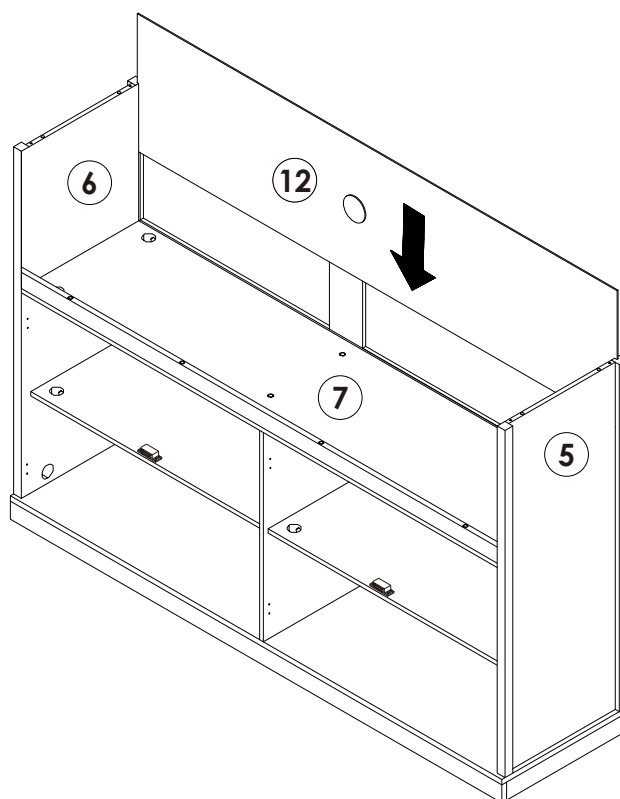

STEP 16

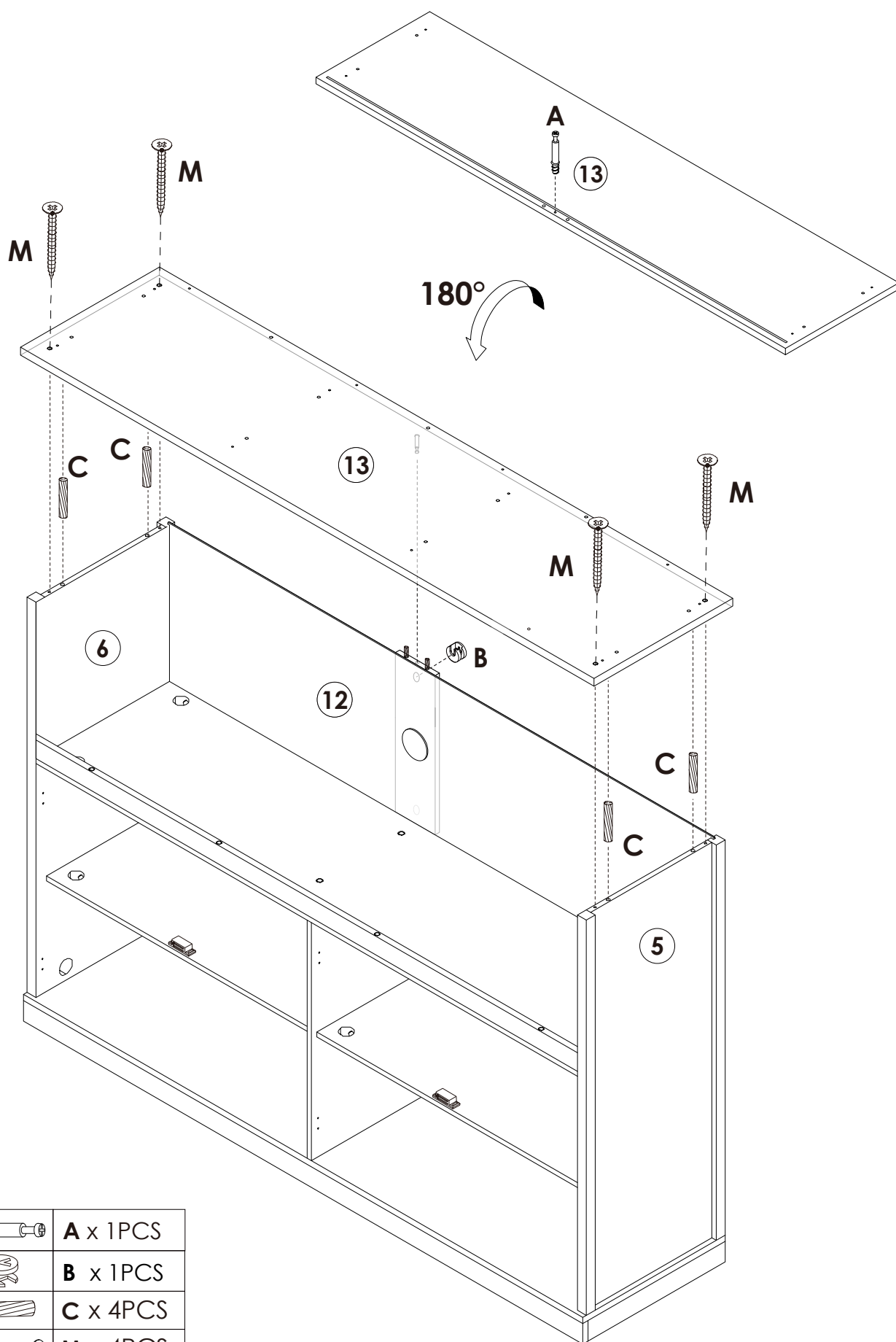

Assembly Steps(EN) / Montageschritte(DE)

STEP 17



	A x 1PCS
	B x 1PCS
	C x 4PCS
	M x 4PCS

Assembly Steps(EN) / Montageschritte(DE)

STEP 18

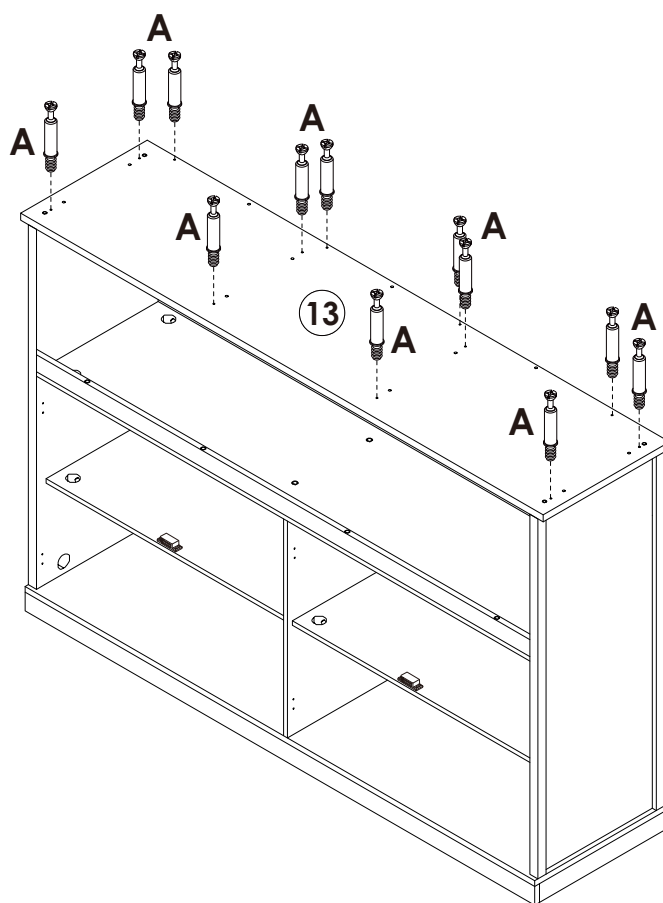

 **A x 12PCS**

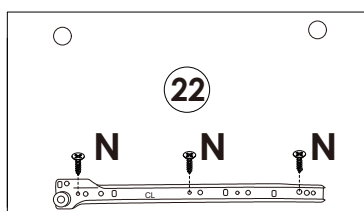
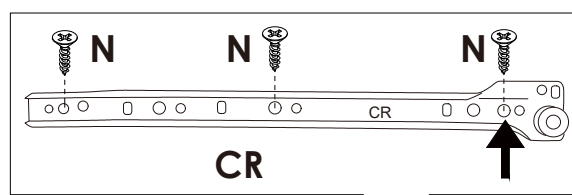
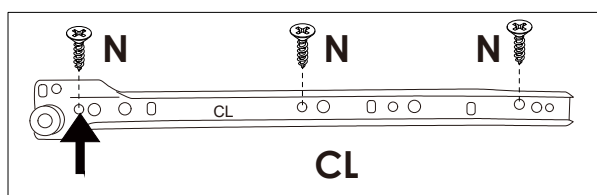

STEP 19

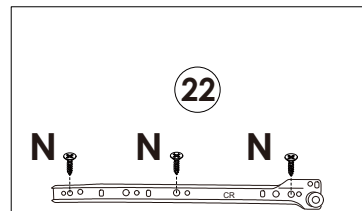

180°



Turn over part 22 to install the other side.

	N x 12PCS
	CL x 2PCS
	CR x 2PCS

x2

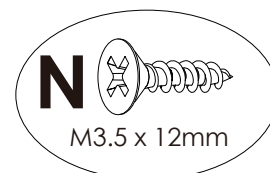

Assembly Steps(EN) / Montageschritte(DE)

STEP 20

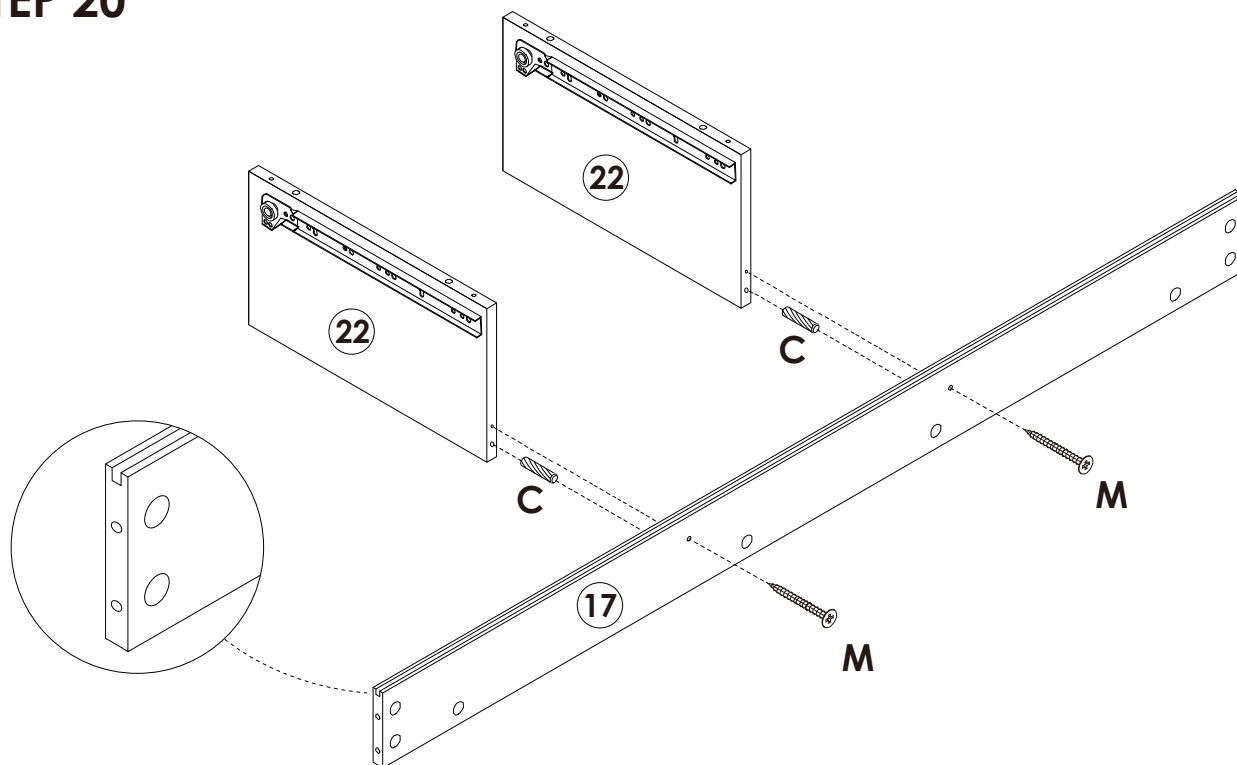

	C x 2PCS
	M x 2PCS

STEP 21

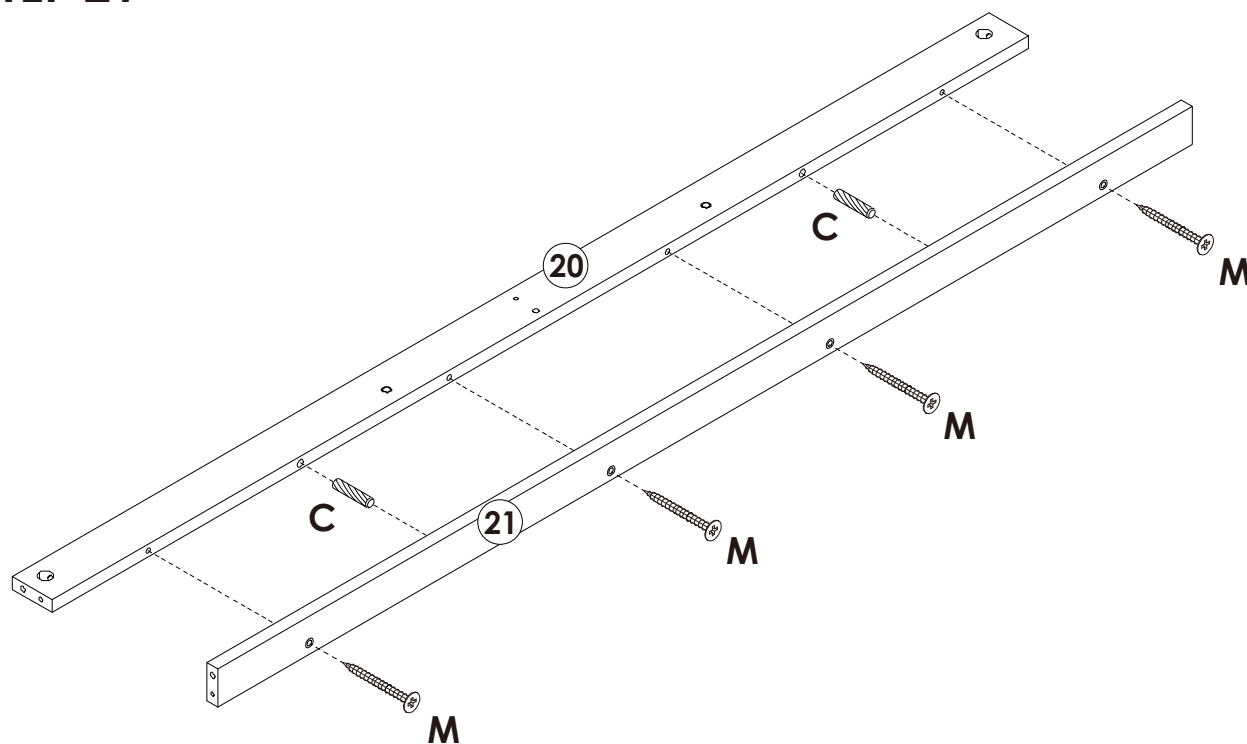

	C x 2PCS
	M x 4PCS

Assembly Steps(EN) / Montageschritte(DE)

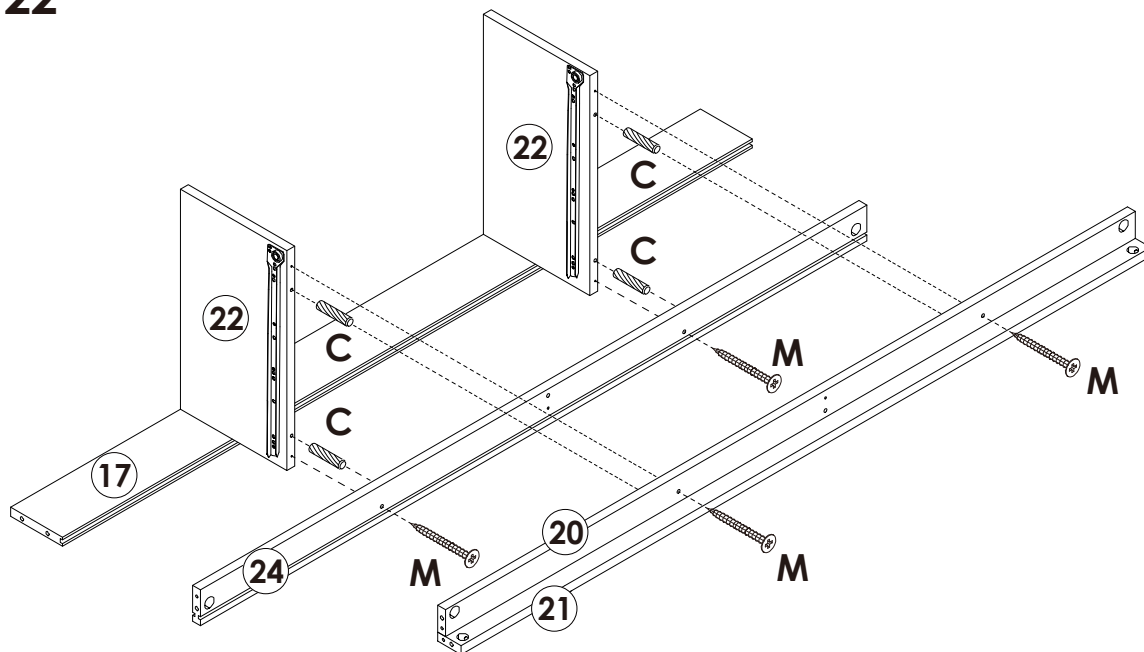

STEP 22

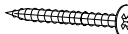

	C x 4PCS
	M x 4PCS

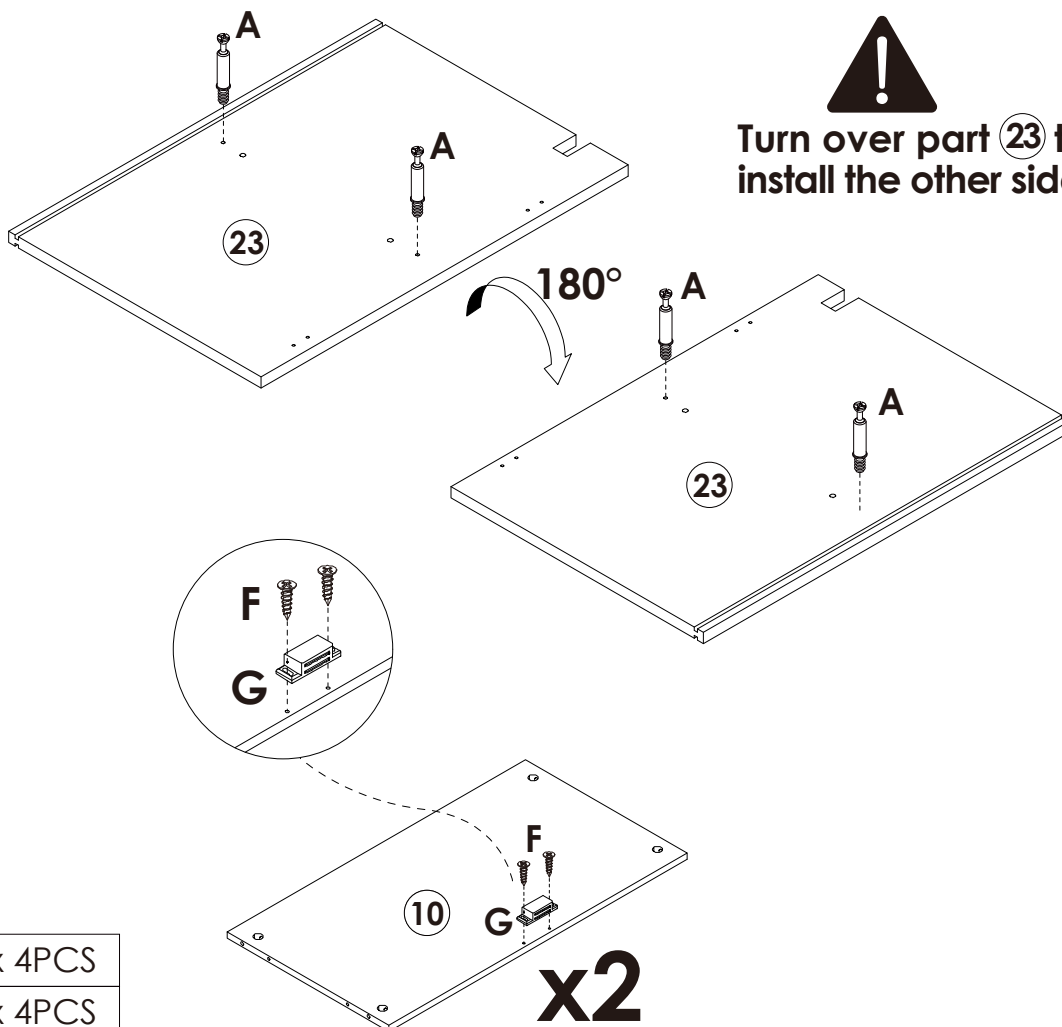
STEP 23



	A x 4PCS
	F x 4PCS
	G x 2PCS

Assembly Steps(EN) / Montageschritte(DE)

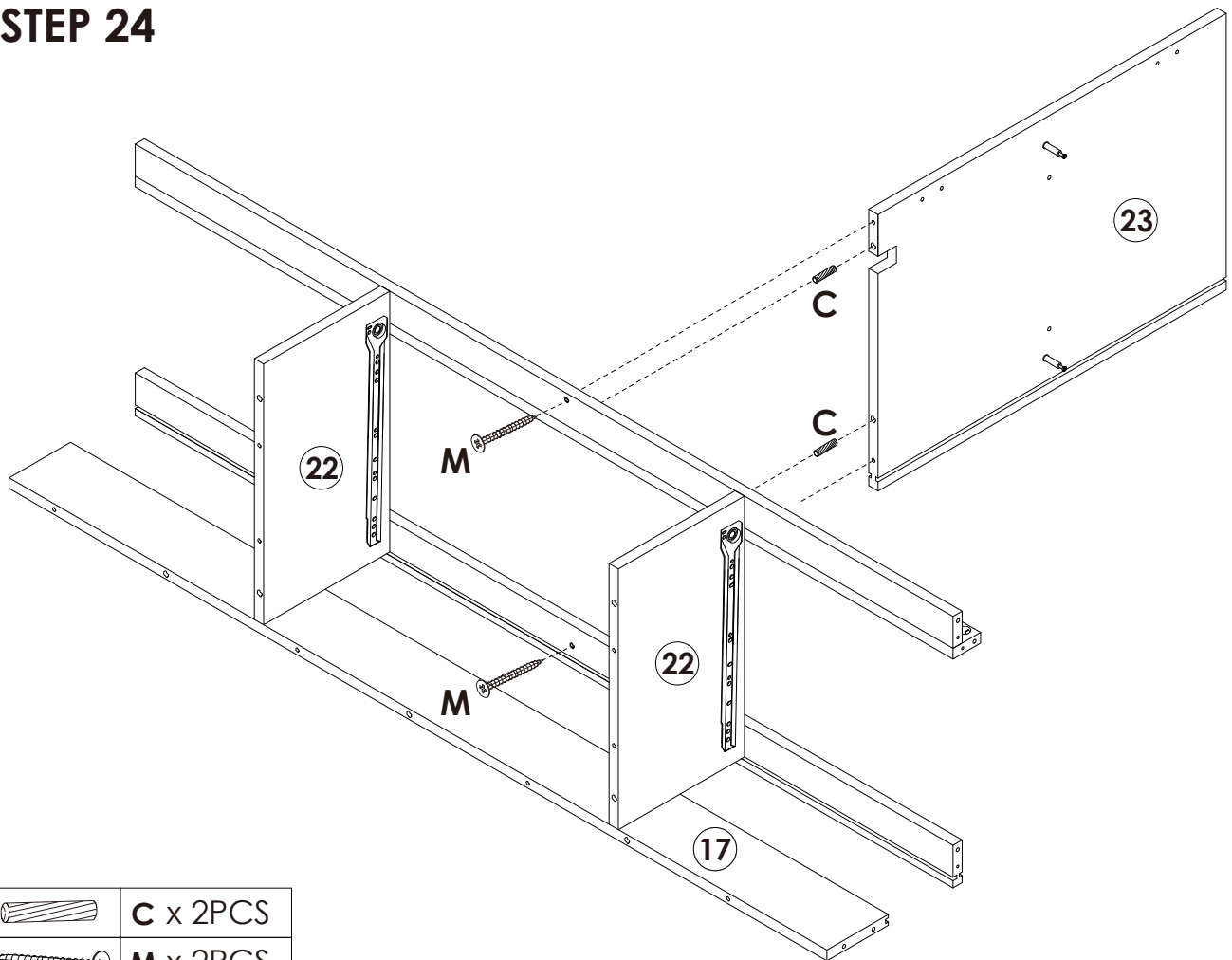

STEP 24

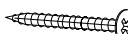

	C x 2PCS
	M x 2PCS

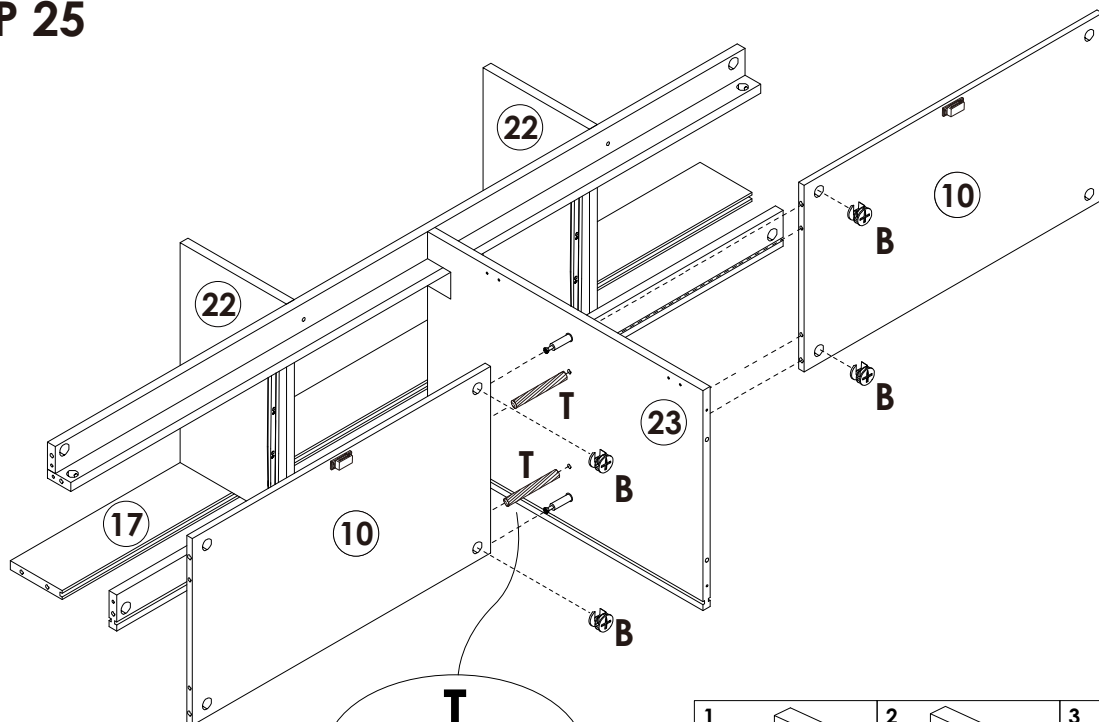
STEP 25





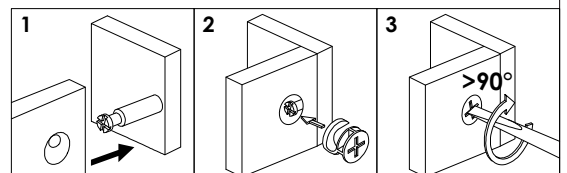
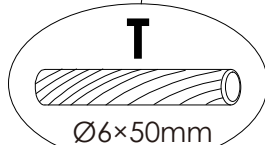

	B x 4PCS
	T x 2PCS

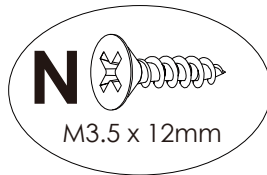
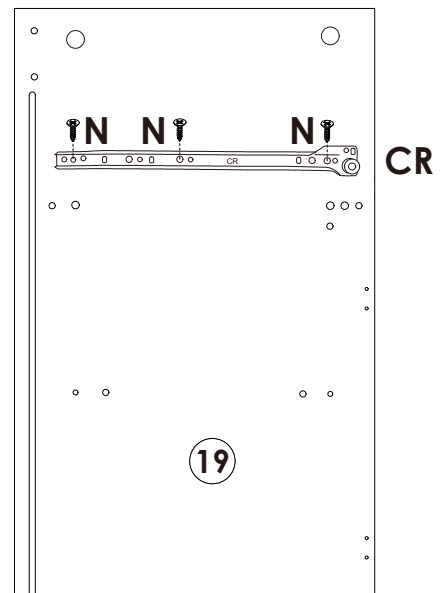
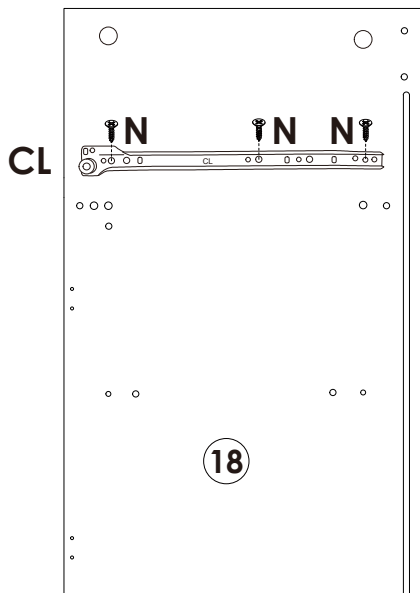
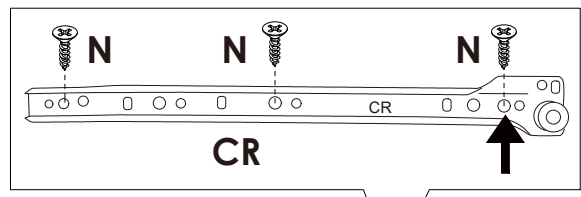
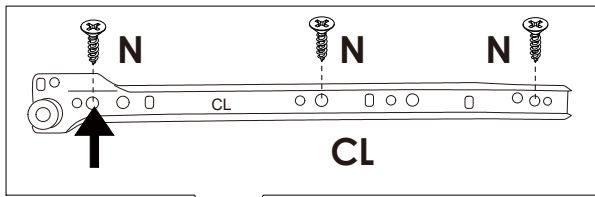

Assembly Steps(EN) / Montageschritte(DE)

STEP 26



	N x 6PCS
	CL x 1PCS
	CR x 1PCS

STEP 27

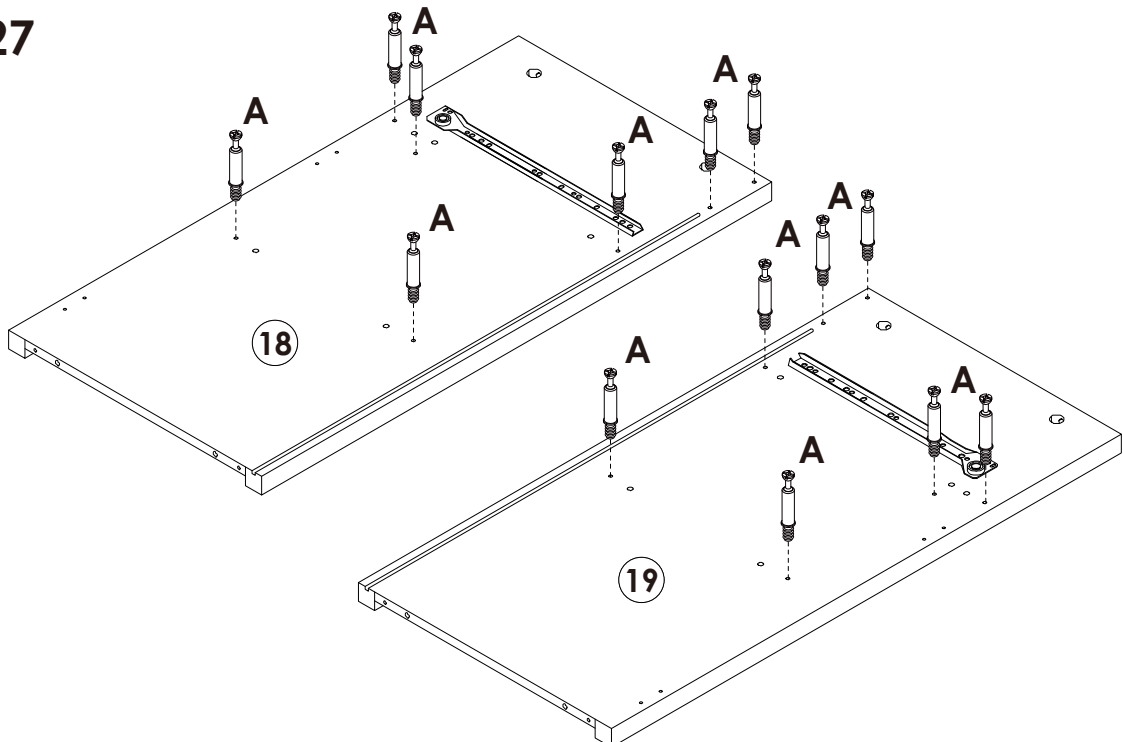



	A x 14PCS
-------------------------------------------------------------------------------------	------------------

Assembly Steps(EN) / Montageschritte(DE)

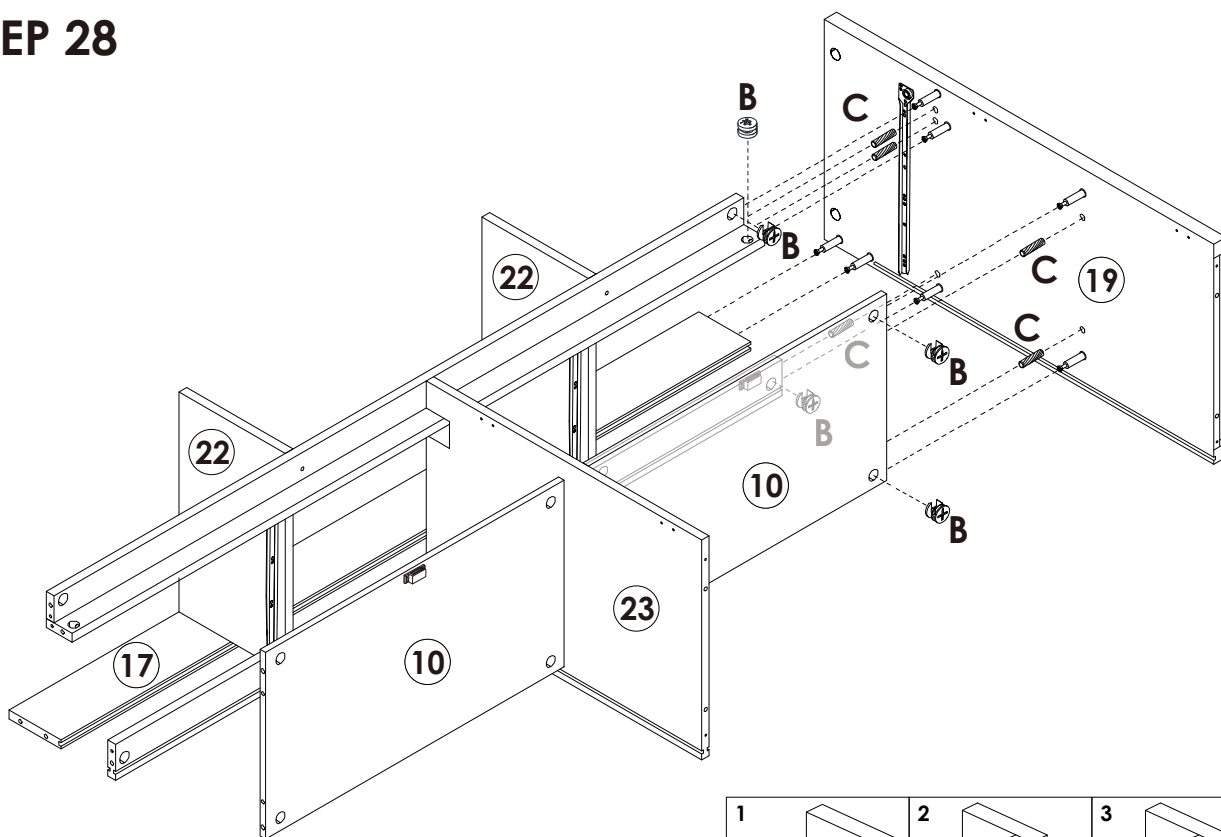
STEP 28



	B x 5PCS
	C x 5PCS

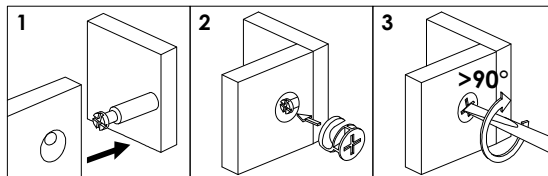

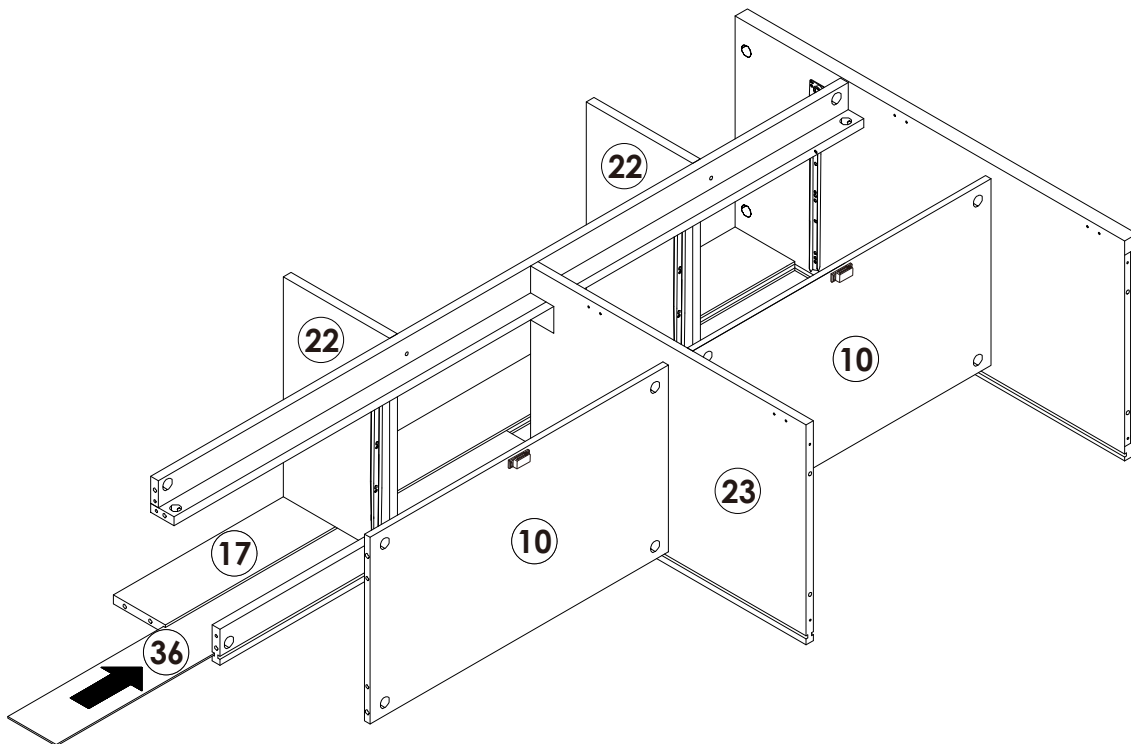

STEP 29



Assembly Steps(EN) / Montageschritte(DE)

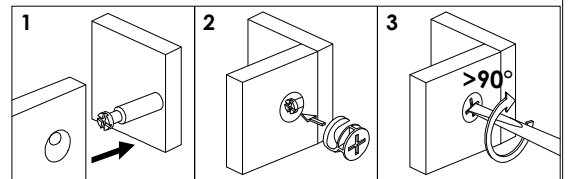
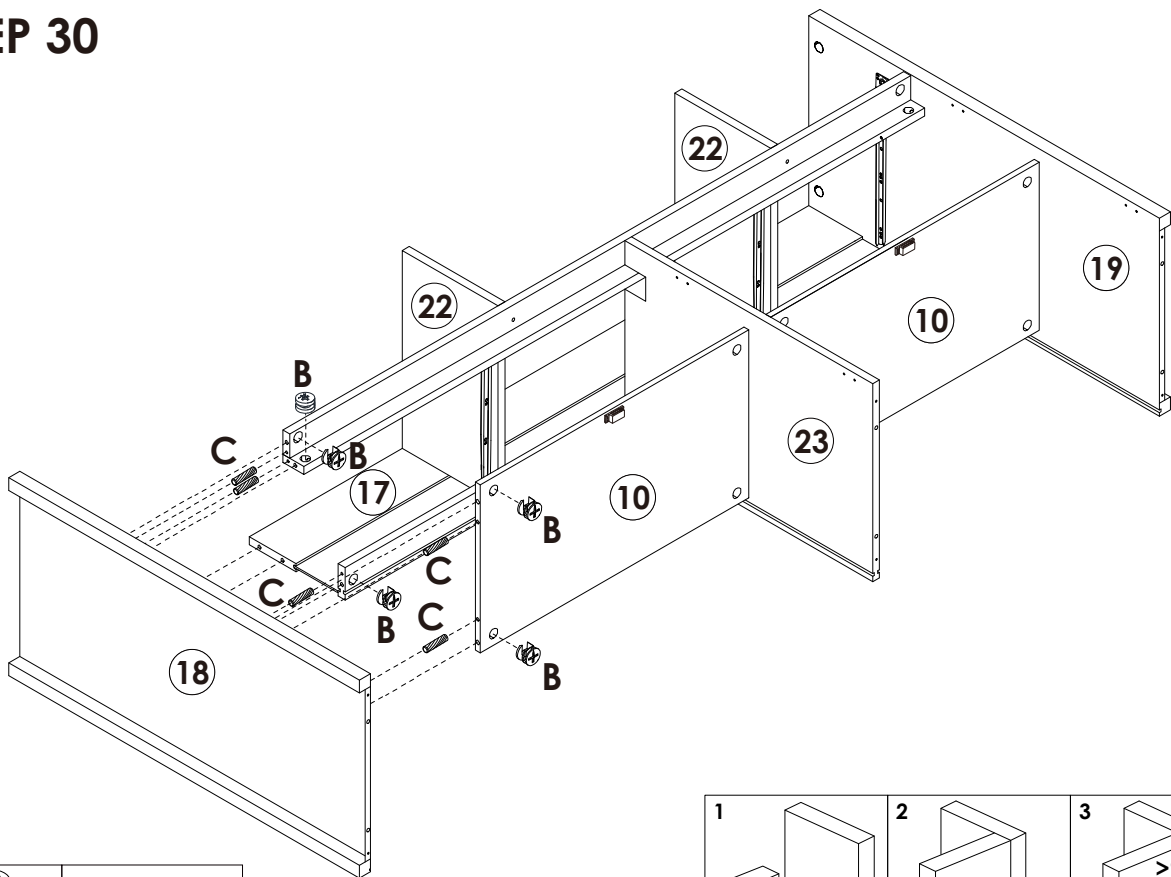

STEP 30

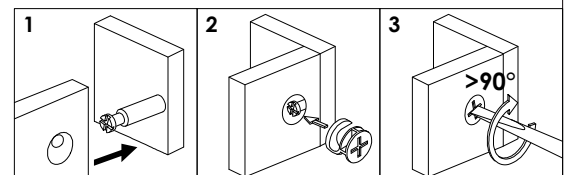
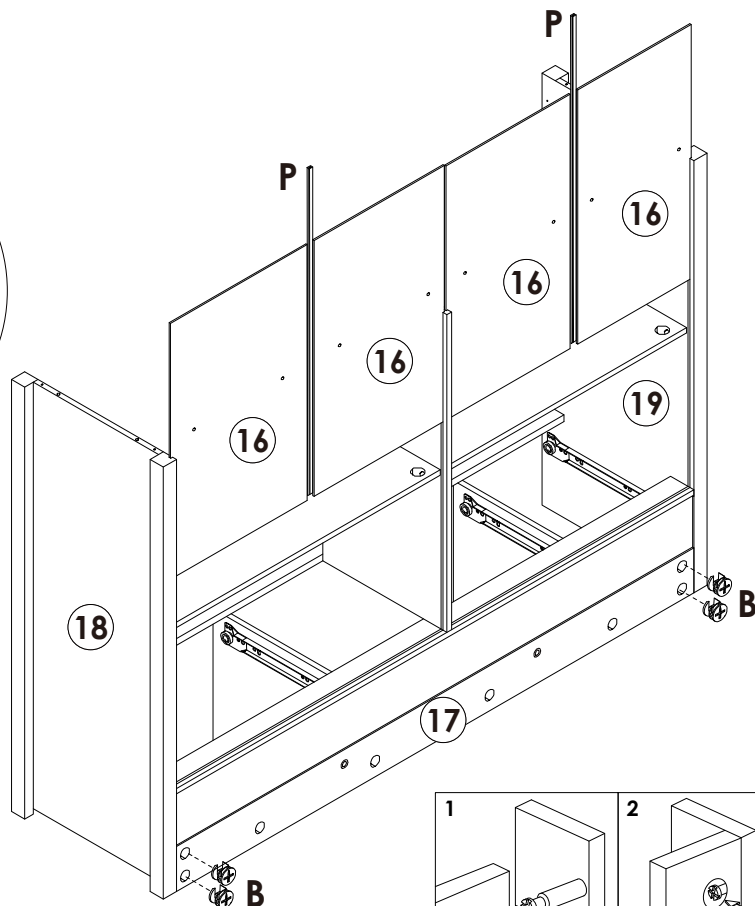
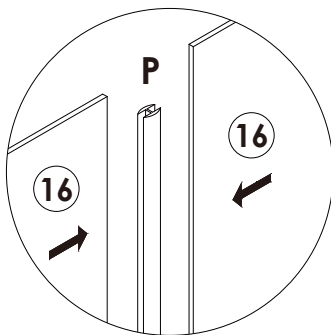

	B x 5PCS
	C x 5PCS

STEP 31



	B x 4PCS
	P x 2PCS
	L=564mm

Assembly Steps(EN) / Montageschritte(DE)

STEP 32

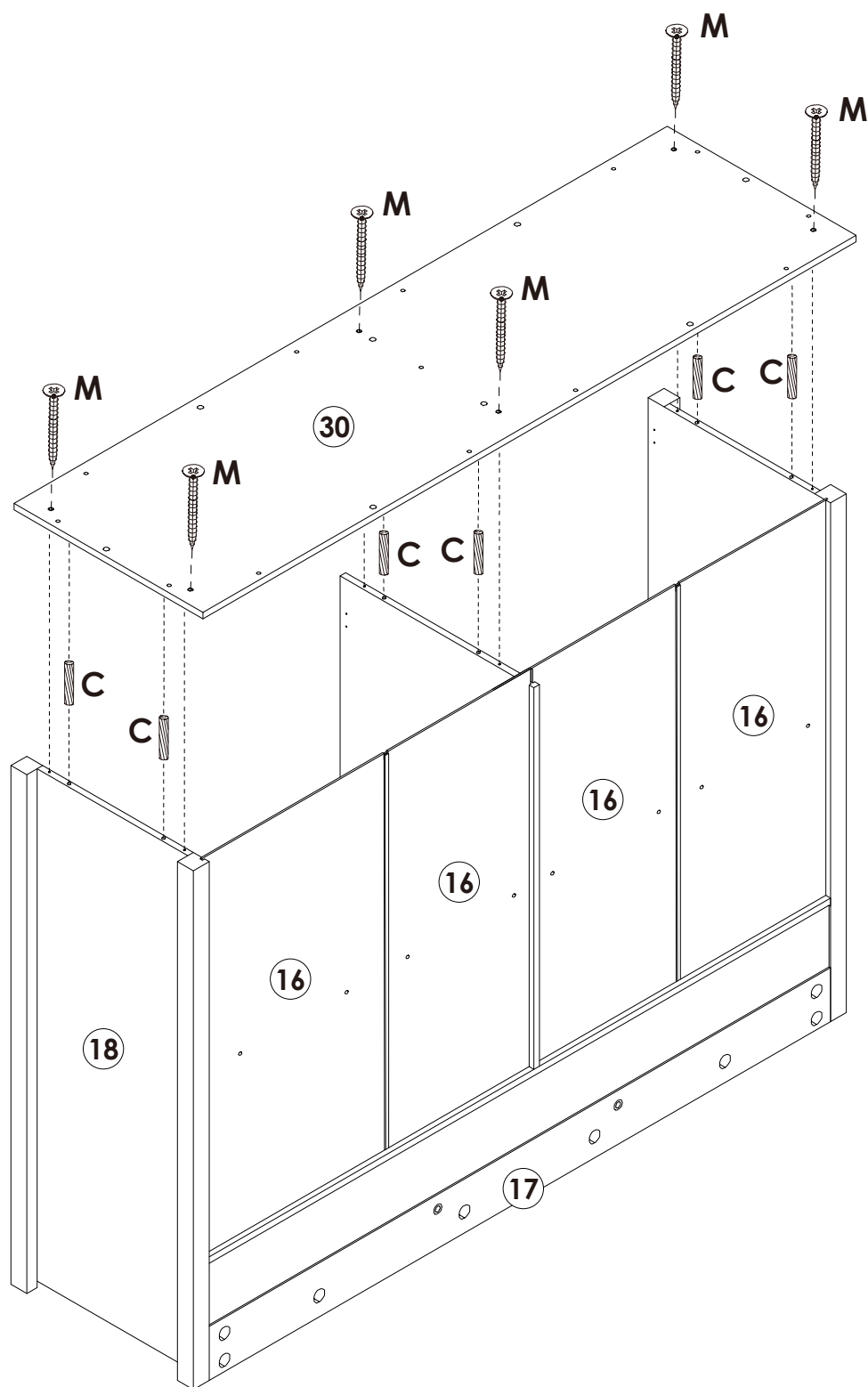

	C x 6PCS
	M x 6PCS

Assembly Steps(EN) / Montageschritte(DE)

STEP 33

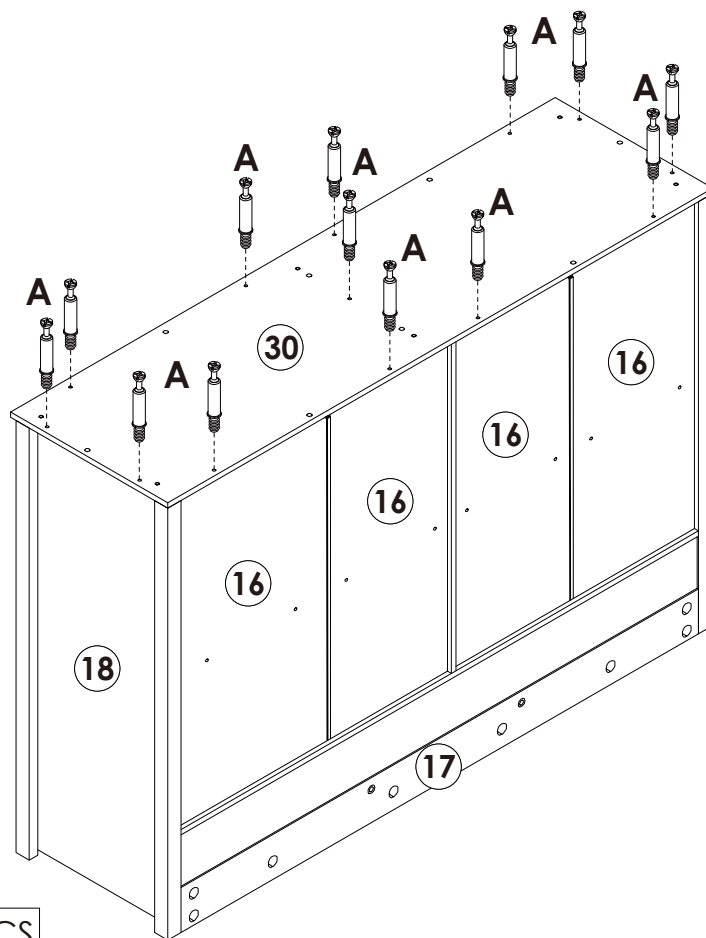

 A x 13PCS

STEP 34

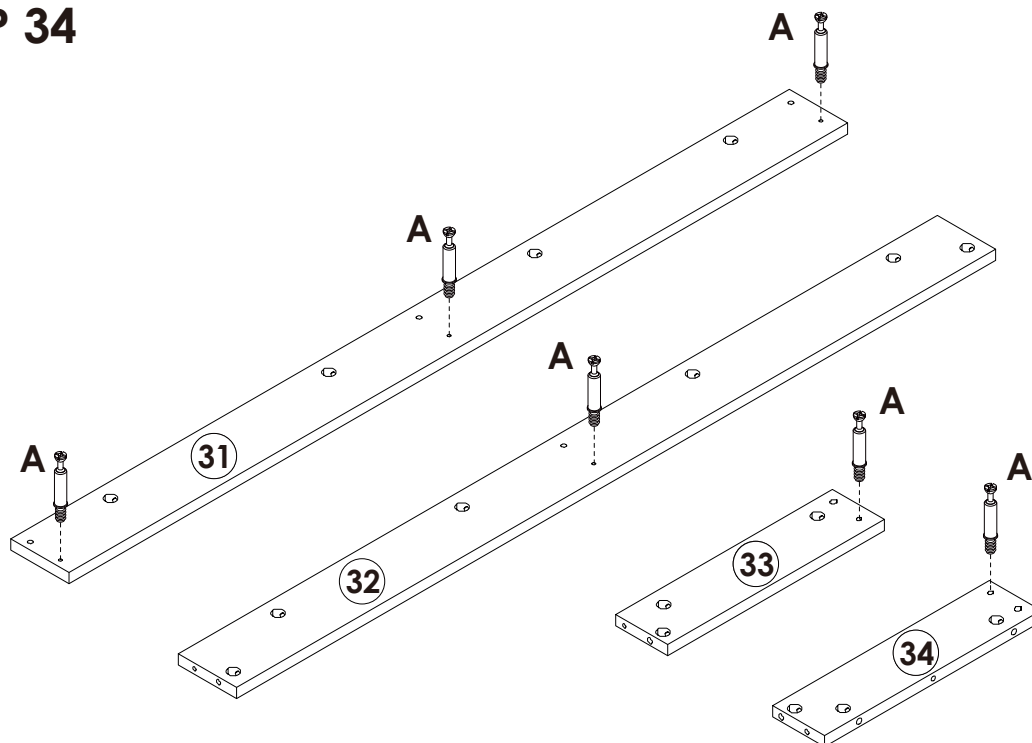



 A x 6PCS

Assembly Steps(EN) / Montageschritte(DE)

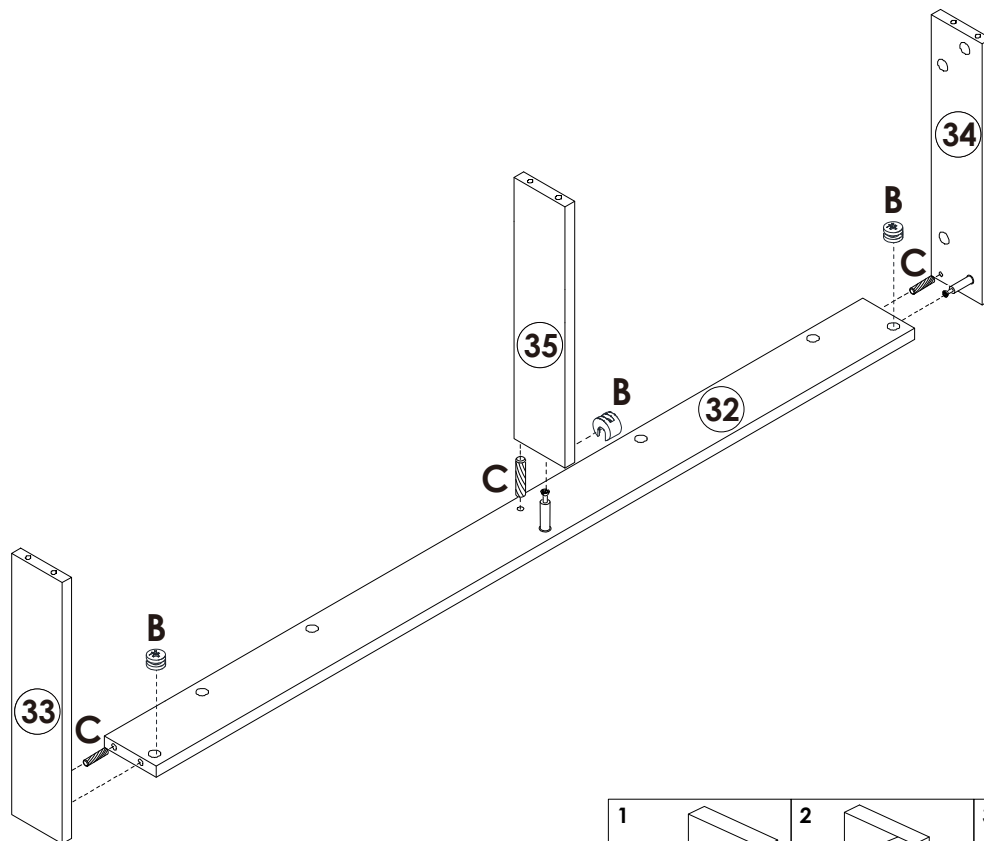
STEP 35



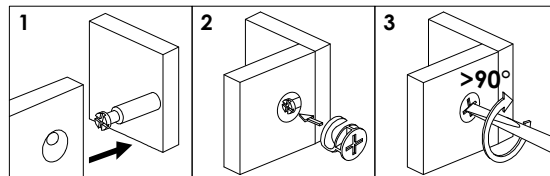

	B x 3PCS
	C x 3PCS

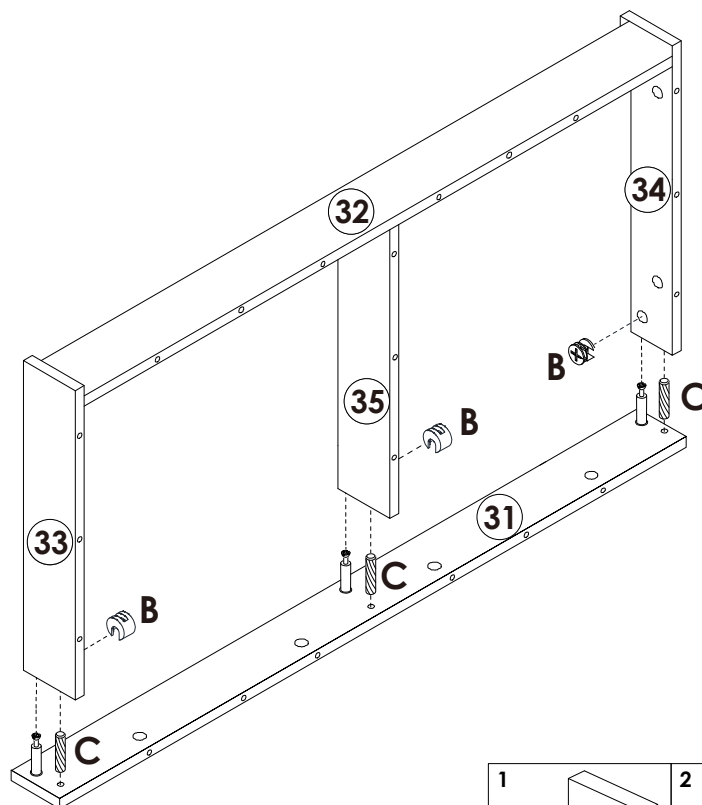

STEP 36



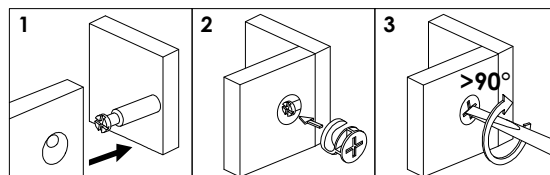

	B x 3PCS
	C x 3PCS

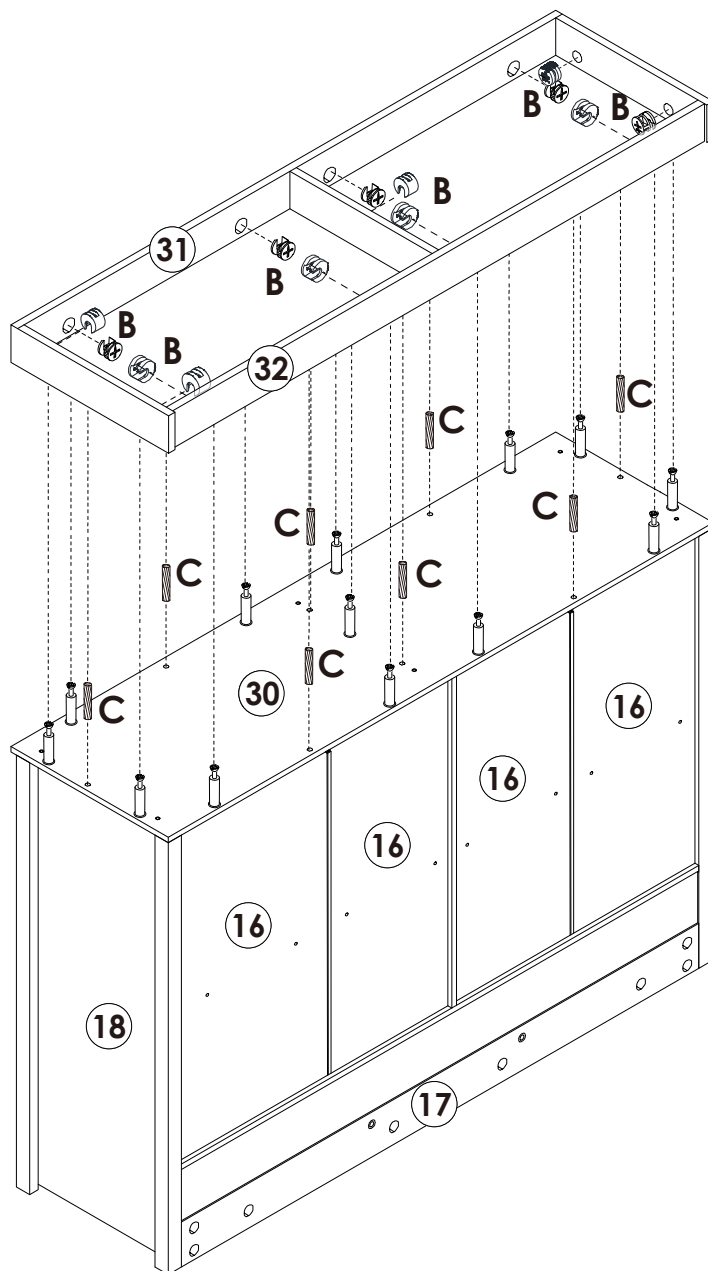

STEP 37



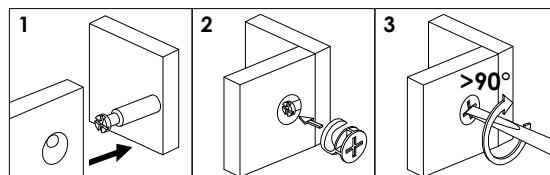

	B x 13PCS
	C x 8PCS

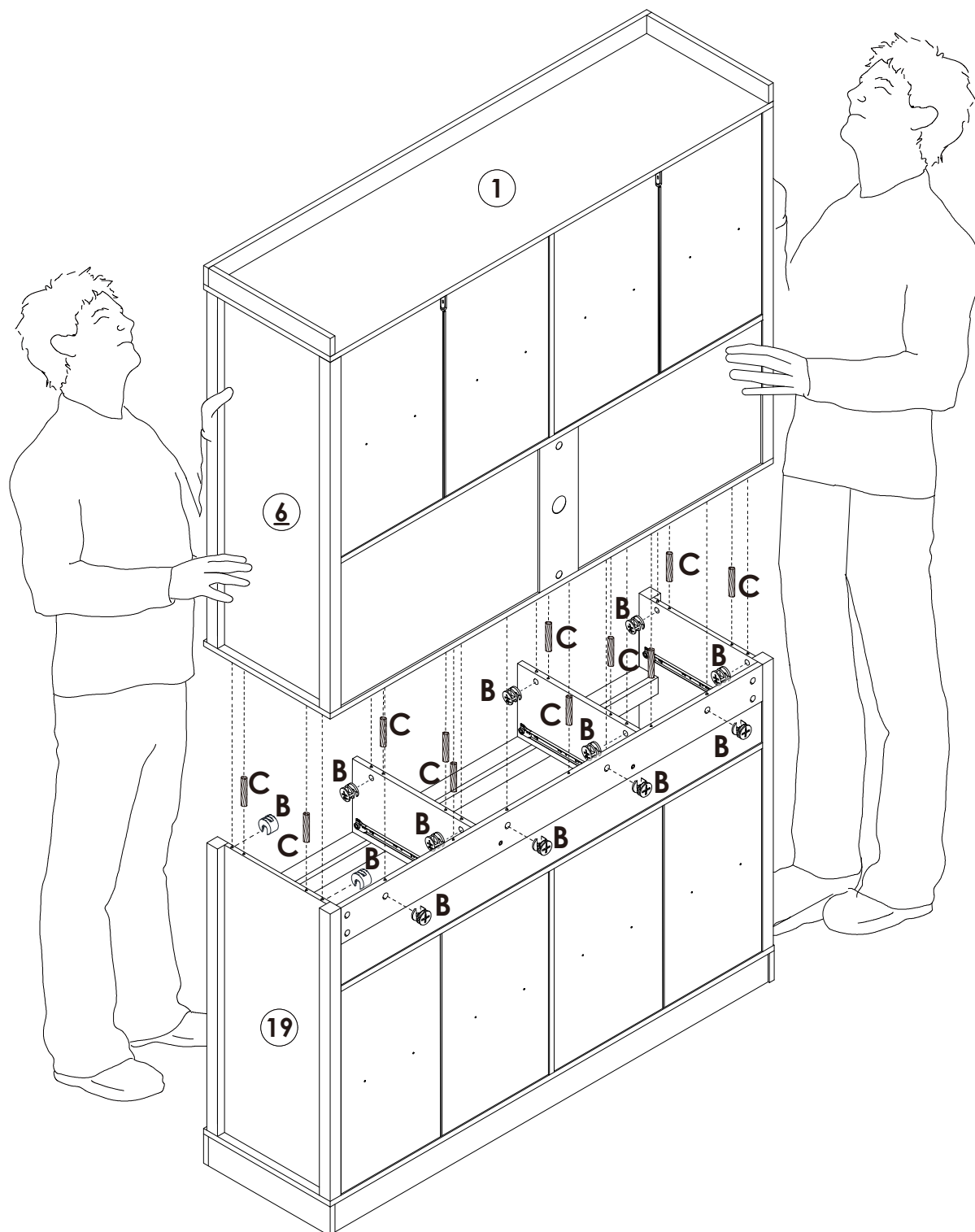

Assembly Steps(EN) / Montageschritte(DE)

STEP 38



	B x 12PCS
	C x 11PCS

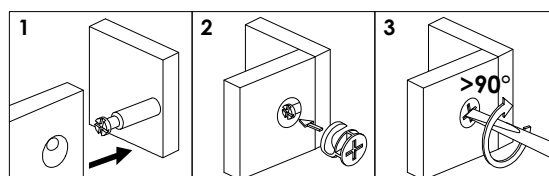



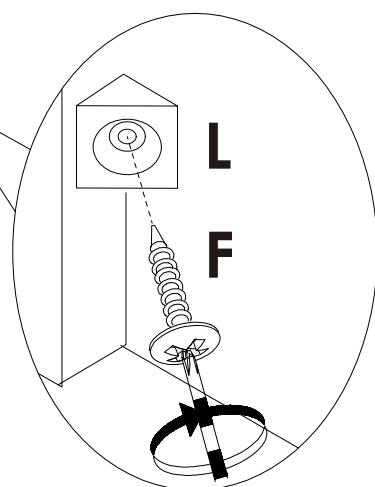
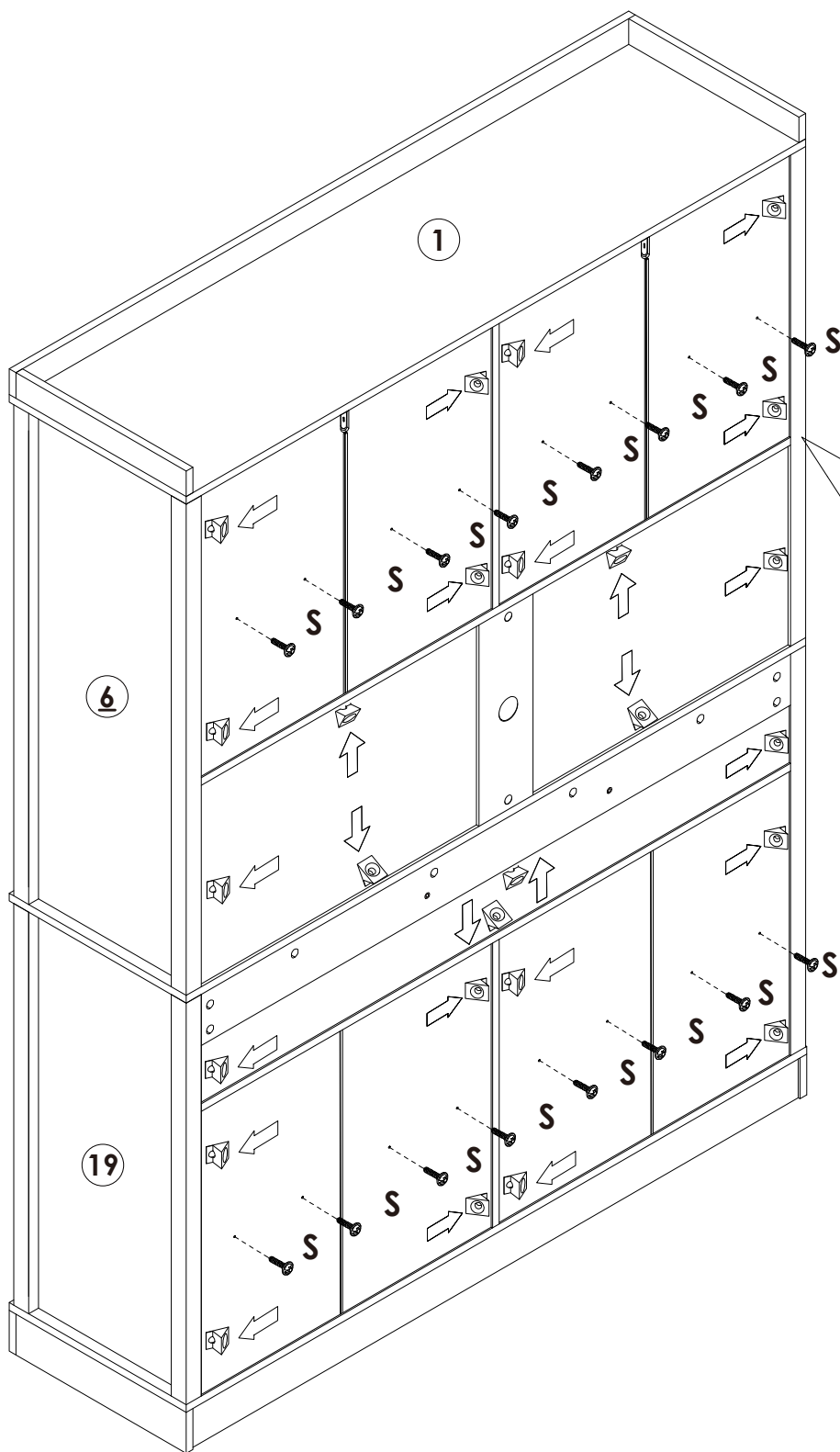

Assembly Steps(EN) / Montageschritte(DE)

STEP 39

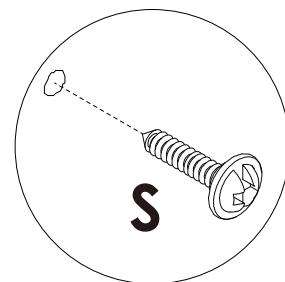

x26



	F x 26PCS
	L x 26PCS
	S x 16PCS

Assembly Steps(EN) / Montageschritte(DE)

STEP 40

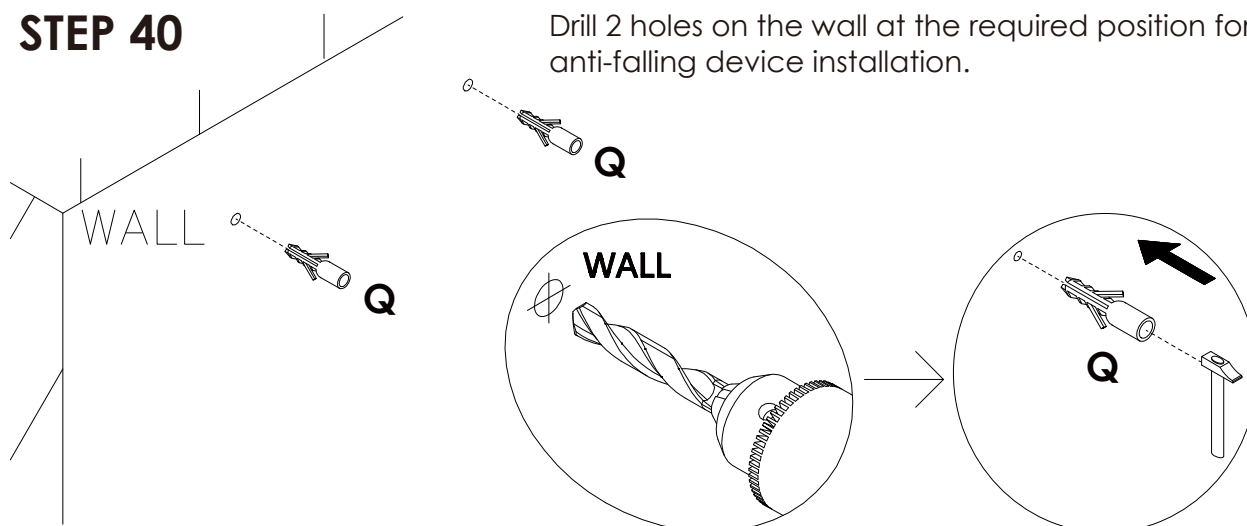

Q x 2PCS

STEP 41

Move the cabinet to the required position, use the "M" long screw to fix the cabinet to the wall.

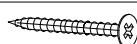
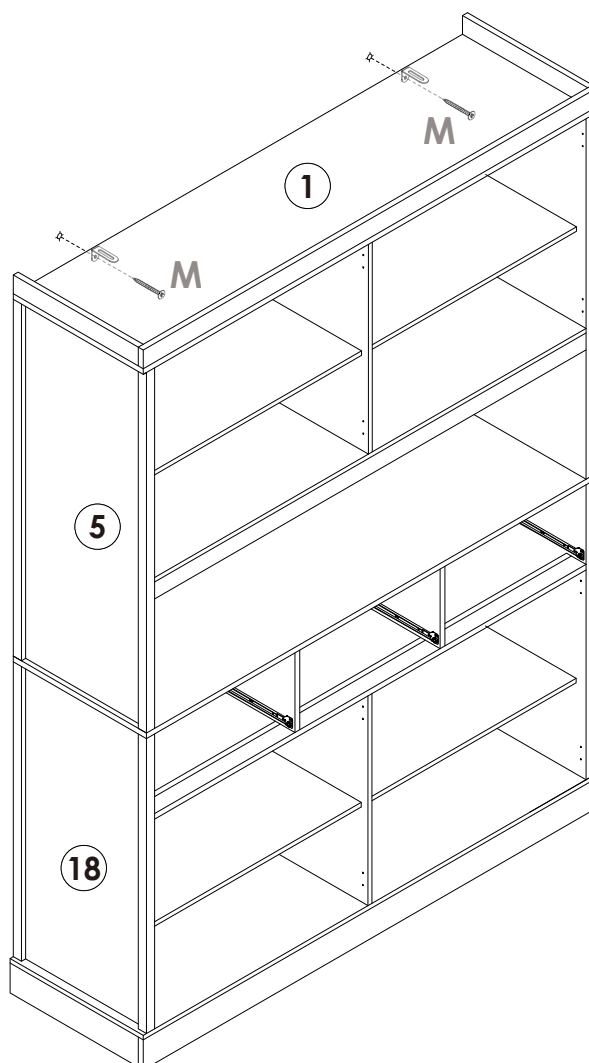

M x 2PCS



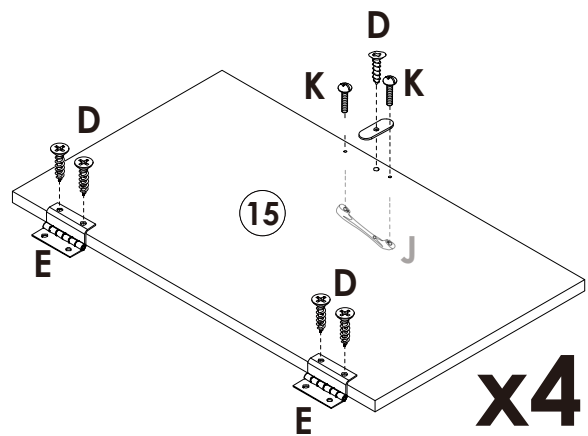
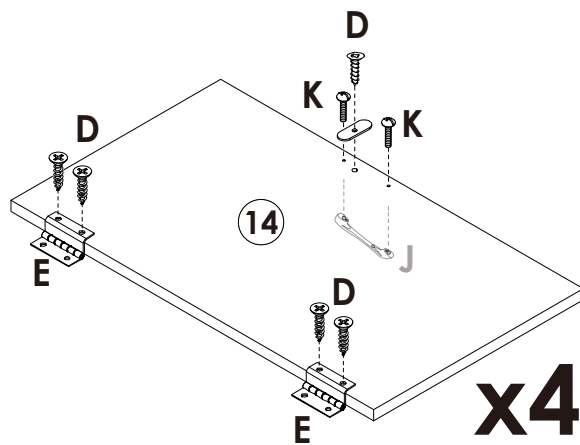

Assembly Steps(EN) / Montageschritte(DE)

STEP 42



x4

x4

	D x 40PCS
	E x 16PCS
	H x 8PCS
	J x 8PCS
	K x 16PCS

STEP 43

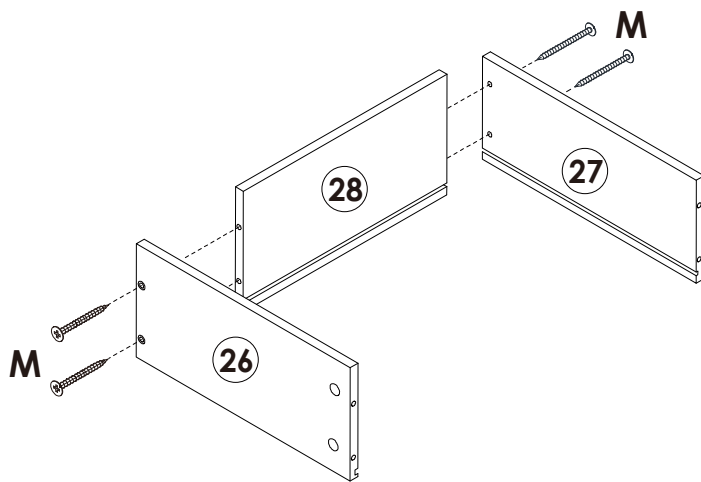

x3

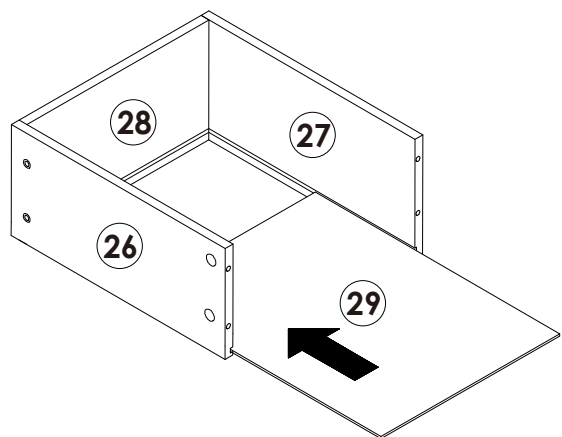



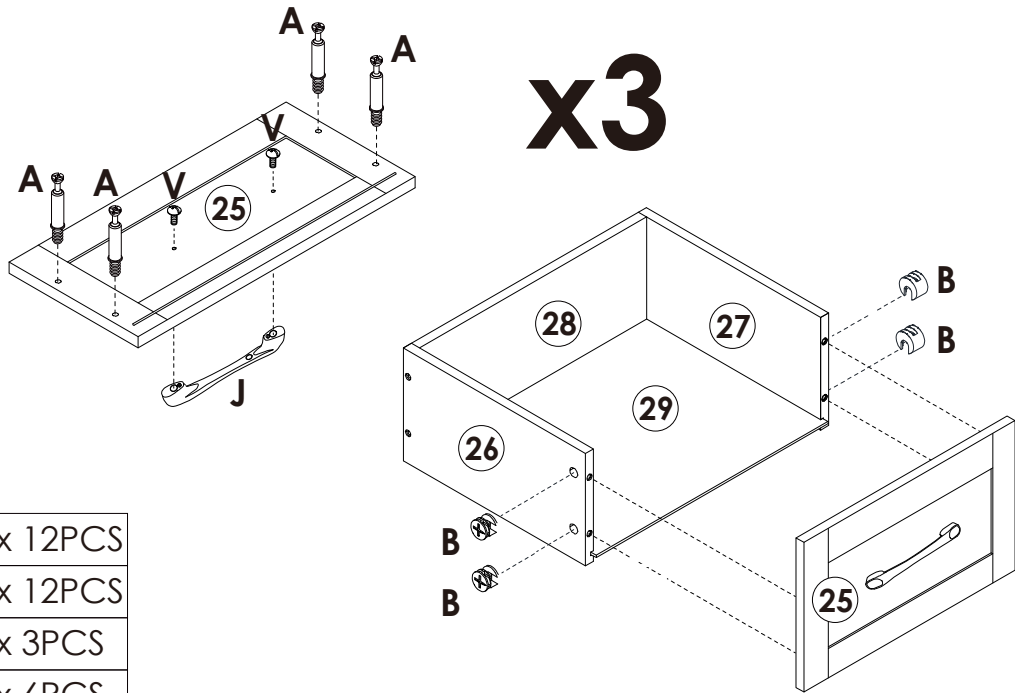

	M x 12PCS
-------------------------------------------------------------------------------------	------------------

Assembly Steps(EN) / Montageschritte(DE)

STEP 44

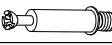

x3

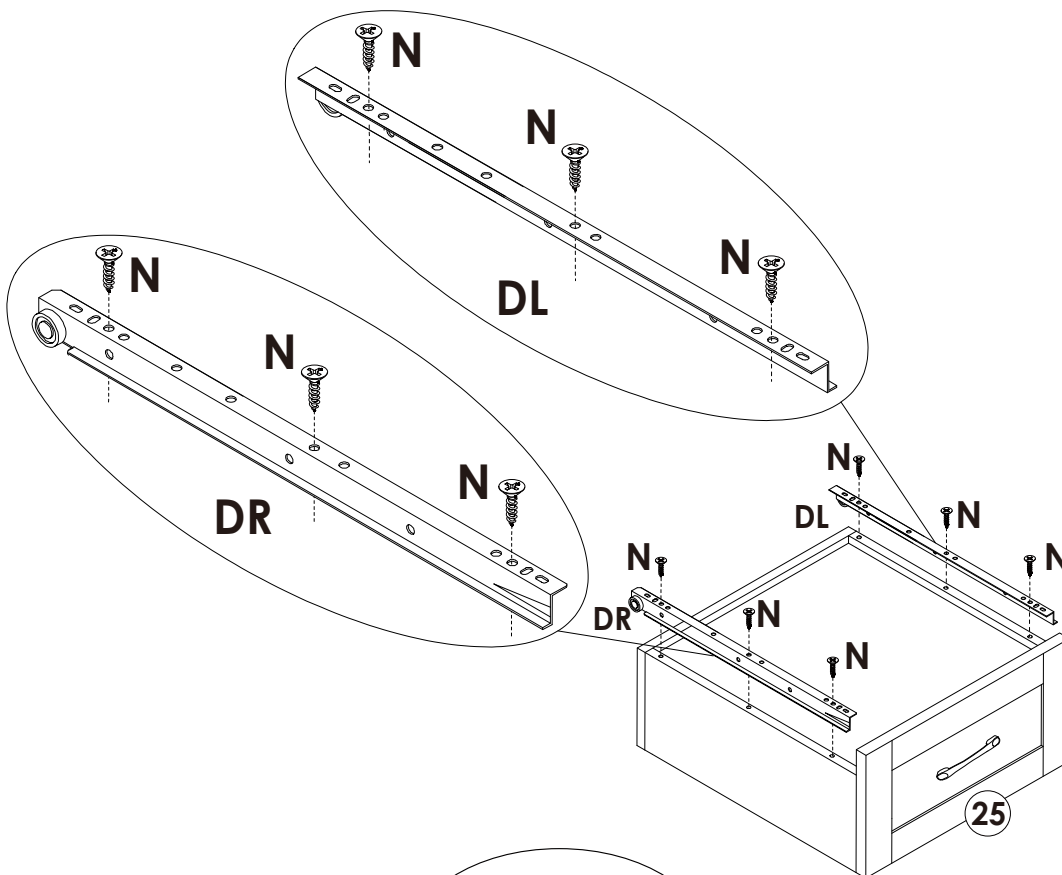

	A x 12PCS
	B x 12PCS
	J x 3PCS
	V x 6PCS

STEP 45

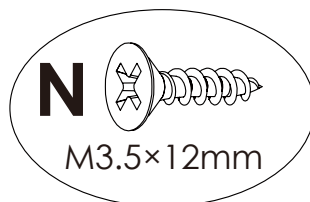

x3



	N x 18PCS
	DL x 3PCS
	DR x 3PCS

STEP 46

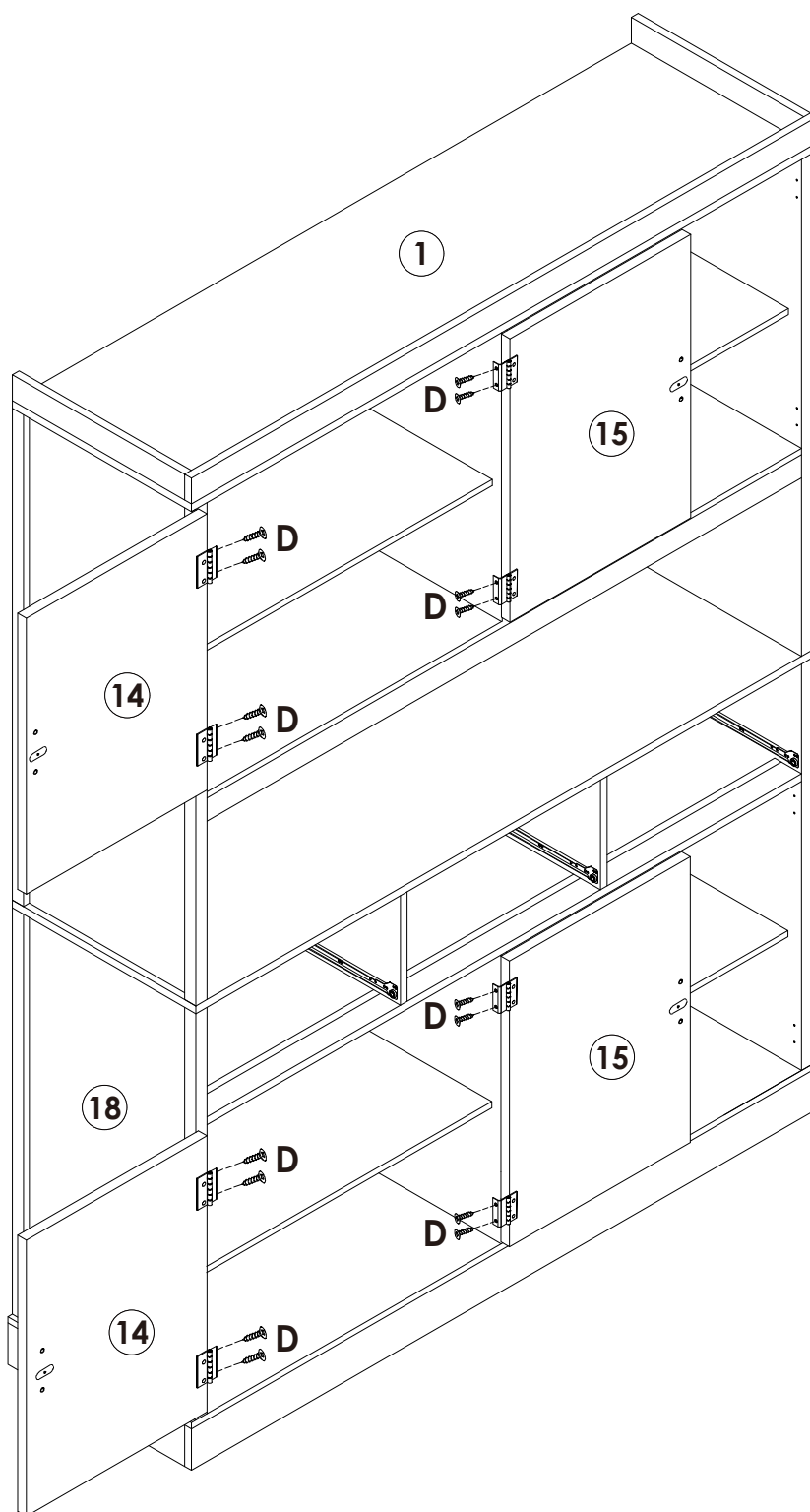

D x 16PCS

Assembly Steps(EN) / Montageschritte(DE)

STEP 47

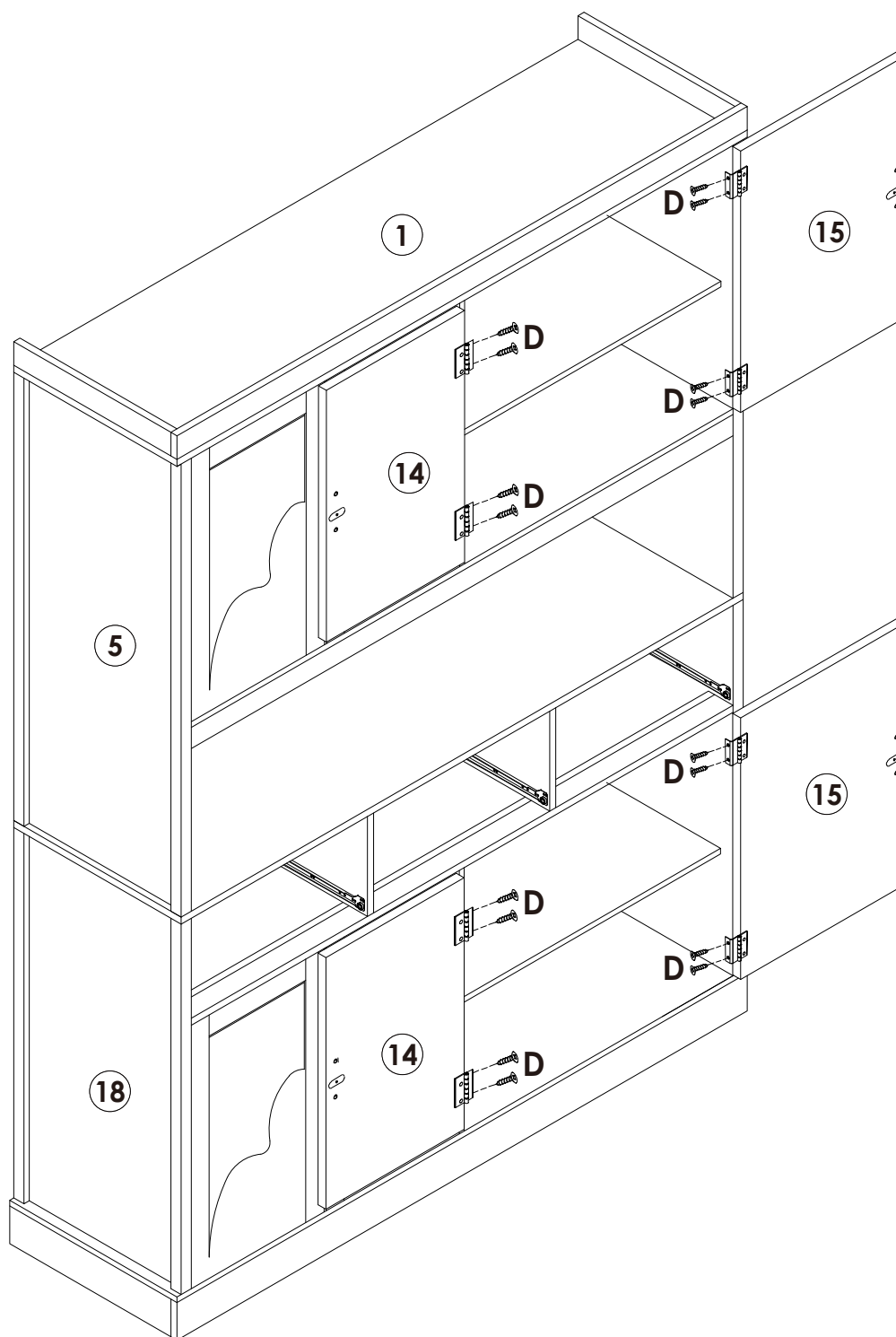

D x 16PCS

Assembly Steps(EN) / Montageschritte(DE)

STEP 48

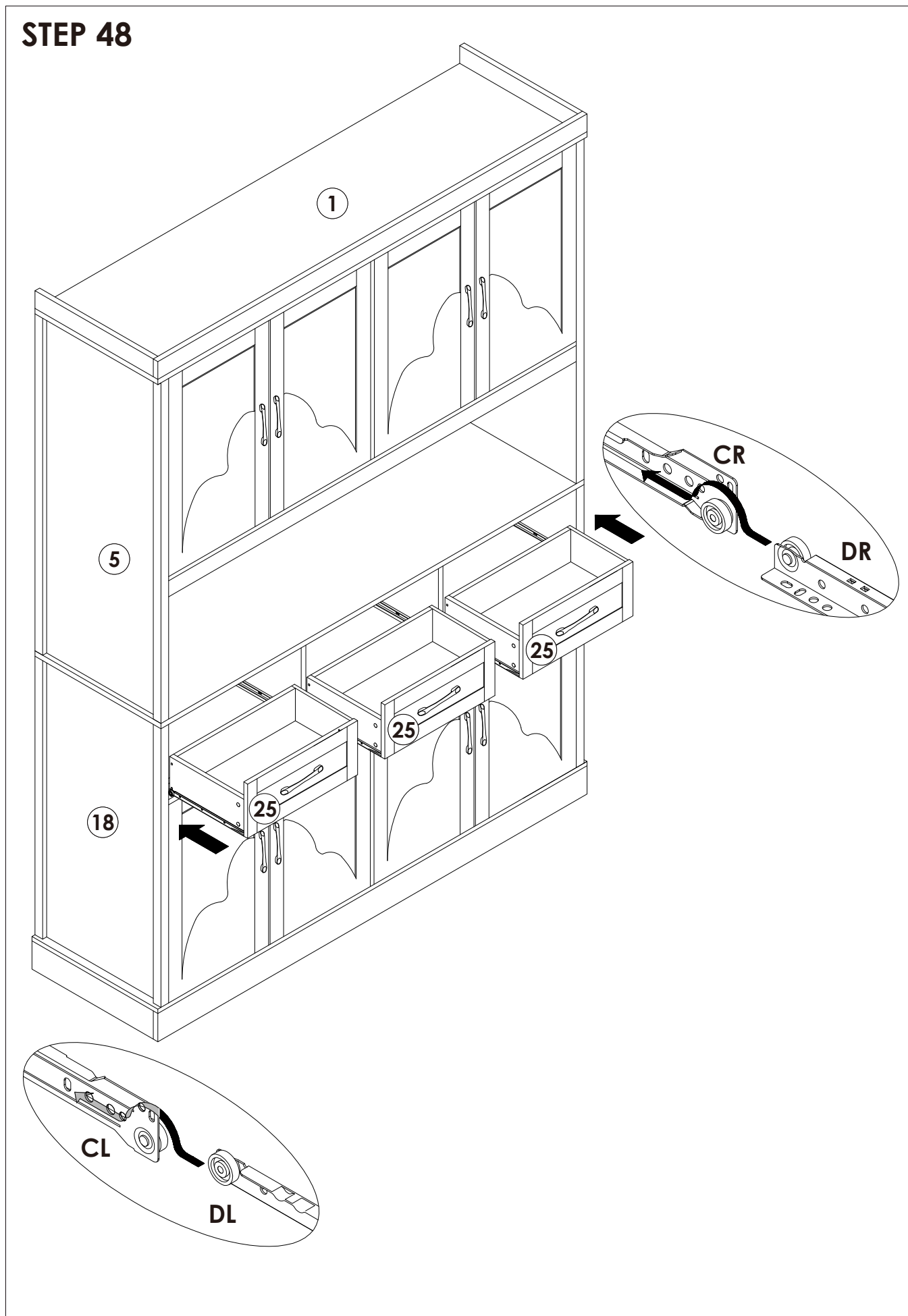



WARNING



Children have died from furniture tipover. To reduce the risk of furniture tipover:

- **ALWAYS** install Anti-tip device provided.
- **NEVER** put a TV on this product.
- **NEVER** allow children to stand, climb or hang on any drawers, doors, or shelves.
- **NEVER** open more than one drawer at a time.
- Place heaviest items in the lowest drawers.



***This is a permanent label.
Do not remove!***