

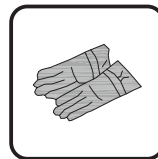

IN230900086V02_GL

84C-470V01_84C-470V02

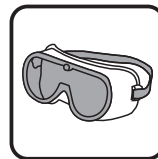
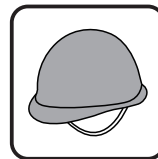
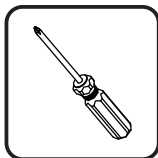
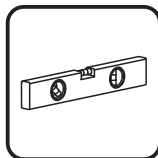
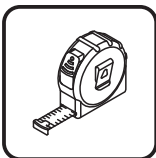
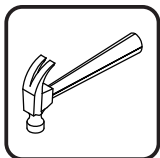
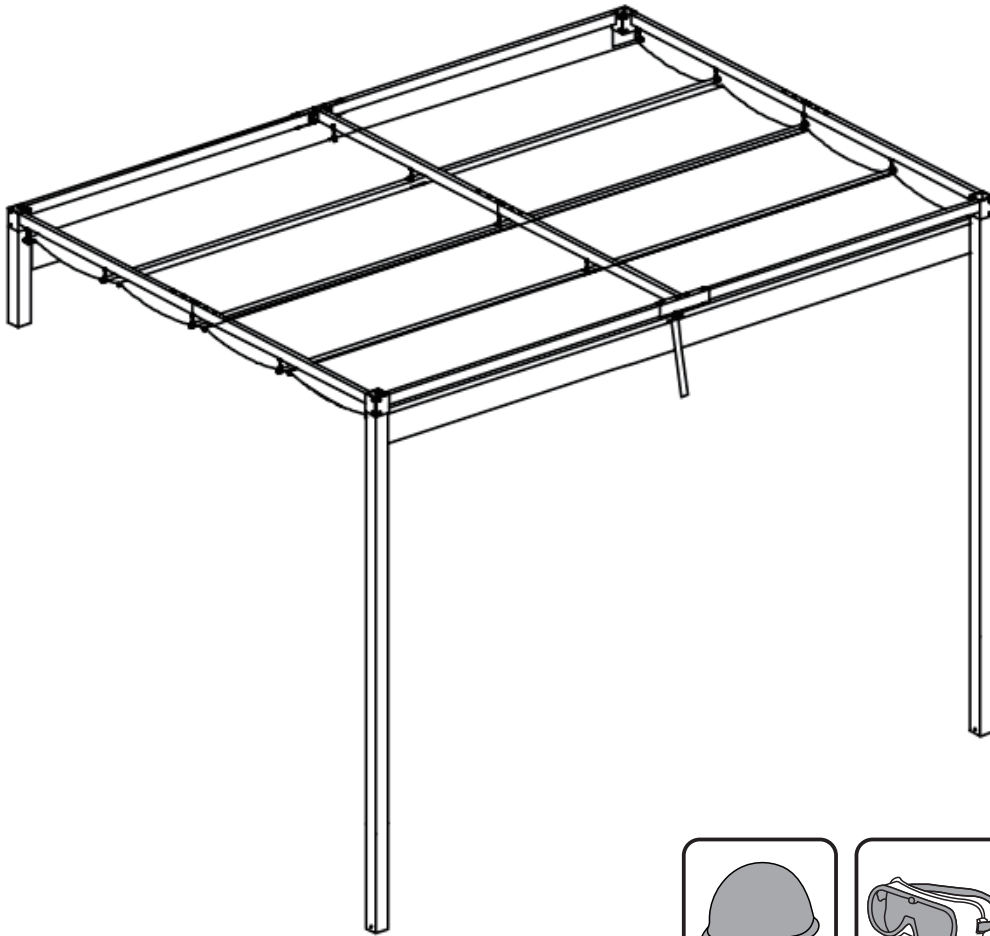

Tools Recommended

EN_IMPORTANT, RETAIN FOR FUTURE REFERENCE: READ CAREFULLY.

FR_IMPORTANT: A LIRE ATTENTIVEMENT ET À CONSERVER POUR CONSULTATION ULTÉRIEURE.

ES_IMPORTANTE, LEA Y GUARDE PARA FUTURAS REFERENCIAS.

PT_IMPORTANTE, RETER PARA REFERÊNCIA FUTURA: LEIA ATENTAMENTE.

DE_WICHTIG! SORGFÄLTIG LESEN UND FÜR SPÄTER NACHSCHLAGEN AUFBEWAHREN.

IT_IMPORTANTE! CONSERVARE IL PRESENTE MANUALE PER FUTURO RIFERIMENTO E LEGGERLO ATTENTAMENTE.

EN

IMPORTANT SAFETY NOTICE

Product is NOT INTENDED for the following:

- A safety barrier to prevent unsupervised access to pools, hot tubs, spas or ponds.
- As load bearing support for a building, structure, heavy objects or swings.
- Used in structures that trap wind, rain or snow that would create extra load on the product.

Accumulated snow must be removed from roof.

DO NOT climb or walk on roof for any reason.

Wear gloves to avoid injury from possible sharp edges of individual elements before assembly.

During installation, follow all safety warnings provided with your tools.

Some structures may require two or more people to install safely.

Check for underground utilities before digging or driving stakes into the ground!

It is important during assembly to closely follow the instructions, complete the assembly on a solid level surface and that you follow the instruction to square up, level and anchor the structure, this will reduce the gap at connections during assembly.

FR

AVIS IMPORTANT DE SÉCURITÉ

Le produit n'est PAS DESTINÉ à ce qui suit :

- Une barrière de sécurité pour empêcher l'accès non surveillé aux piscines, aux spas, aux cuves thermales ou aux étangs.
- Comme support de charge pour un bâtiment, une structure, des objets lourds ou des balançoires.
- Utilisé dans des structures qui retiennent le vent, la pluie ou la neige qui créeraient une charge supplémentaire sur le produit.

La neige accumulée doit être enlevée du toit.

NE PAS grimper ou marcher sur le toit pour quelque raison que ce soit.

Portez des gants pour éviter les blessures causées par d'éventuels bords tranchants des composants avant de procéder à l'assemblage.

Lors de l'installation, respectez tous les avertissements de sécurité fournis avec vos outils.

Certaines structures peuvent nécessiter l'intervention de deux personnes ou plus pour les installer en toute sécurité.

Vérifiez la présence de services publics souterrains avant de creuser ou de planter des piquets dans le sol !

Il est important, pendant tout le processus de montage, de suivre attentivement les instructions, de terminer l'assemblage sur une surface solide et plane et de suivre les instructions d'équerrage, de mise à niveau et d'ancrage de la structure, ce qui permettra de réduire les écarts au niveau des liaisons pendant le montage.

ES

AVISO IMPORTANTE DE SEGURIDAD

Manténgase alejado de las líneas eléctricas aéreas.

No coloque ni instale su tienda de campaña debajo de los árboles debido a posibles rayos o hundimiento de las ramas de los árboles en condiciones climáticas adversas. Para obtener las mejores condiciones en caso de viento fuerte, coloque el extremo estrecho de la tienda en la dirección del viento.

No dejes caer la tienda de campaña.

No haga rebotar ni golpee la bolsa de la tienda para sacarla, estas acciones podrían dañar el marco.

ESTE PRODUCTO REQUIERE UN MÍNIMO DE DOS PERSONAS PARA SU MONTAJE

Bajo ninguna circunstancia se debe utilizar este producto para cubrir automóviles, vehículos marinos o artículos similares.

PRECAUCIÓN: Vigile no pellizcarse los dedos durante el montaje y desmontaje de la tienda al unir las piezas del marco.

AVISO DE SEGURANÇA IMPORTANTE

O produto NÃO é DESTINADO ao seguinte:

- Uma barreira de segurança para impedir o acesso sem supervisão a piscinas, banheiras, spas ou lagos.
- Como suporte de carga para um edifício, estrutura, objectos pesados ou baloiços.
- Usado em estruturas que apanham vento, chuva ou neve que criariam carga extra sobre o produto.

A neve acumulada deve ser removida do telhado. NÃO subir ou caminhar no telhado por qualquer razão.

Usar luvas para evitar ferimentos causados por possíveis arestas vivas de elementos individuais antes da montagem.

Durante a instalação, siga todos os avisos de segurança fornecidos com as suas ferramentas. Algumas estruturas podem exigir a instalação segura de duas ou mais pessoas. Verifique a existência de utilidades subterrâneas antes de escavar ou de conduzir estacas no solo!

É importante durante a montagem seguir de perto as instruções, completar a montagem numa superfície sólida e nivelar e ancorar a estrutura, o que reduzirá a folga nas ligações durante a montagem.

WICHTIGER SICHERHEITSHINWEIS

Das Produkt ist NICHT für einen der folgenden Anwendungen bestimmt:

- Als Sicherheitsbarriere, die den unbeaufsichtigten Zugang zu Pools, Whirlpools, Spas oder Teichen verhindert.
- Als tragende Stütze für ein Gebäude, eine Struktur, schwere Gegenstände oder Schaukeln.
- Als Bestandteil einer Struktur verwendet werden, welche Wind, Regen oder Schnee abfangen, die eine zusätzliche Belastung für das Produkt darstellen würden.

Angesammelter Schnee muss vom Dach entfernt werden.

Aus keinem Grund darf das Dach bestiegen oder betreten werden.

Bitte tragen Sie stets geeignete Arbeitshandschuhe, um Verletzungen durch mögliche scharfe Kanten einzelner Elemente während der Montage zu vermeiden.

Befolgen Sie während des Installationsprozesses bitte sorgfältig alle Sicherheitswarnungen, die mit Ihren Werkzeugen geliefert werden.

Einige Strukturen können zwei oder mehr Personen erfordern, um sicher installiert zu werden.

Prüfen Sie vor dem Graben oder Eintreiben von Pfählen in den Boden, ob Erdkabel vorhanden sind!

Es ist wichtig, während der Montage die Anweisungen genau zu befolgen, Ihr Produkt auf einem festen und ebenen Untergrund aufzustellen und die Anweisung zum Aufrichten, Nivellieren und Verankern der Struktur zu befolgen, da dadurch der Spalt an den Verbindungen während der Montage verringert wird.

IMPORTANTI PRECAUZIONI DI SICUREZZA

Il prodotto NON è PROGETTATO per quanto segue:

- Una barriera di sicurezza per impedire l'accesso senza supervisione a piscine, vasche idromassaggio, spa o stagni.
- Supporto portante di edifici, strutture, oggetti pesanti o altalene.
- Parte di strutture che accumulano vento, pioggia o neve, in quanto creerebbero un carico extra sul prodotto.

La neve accumulata deve essere rimossa dal tetto.

NON salire o camminare sul tetto per nessun motivo.

Indossare guanti per evitare lesioni derivanti da spigoli vivi dei singoli componenti prima del montaggio.





Durante l'installazione, seguire tutte le precauzioni di sicurezza fornite con gli strumenti.



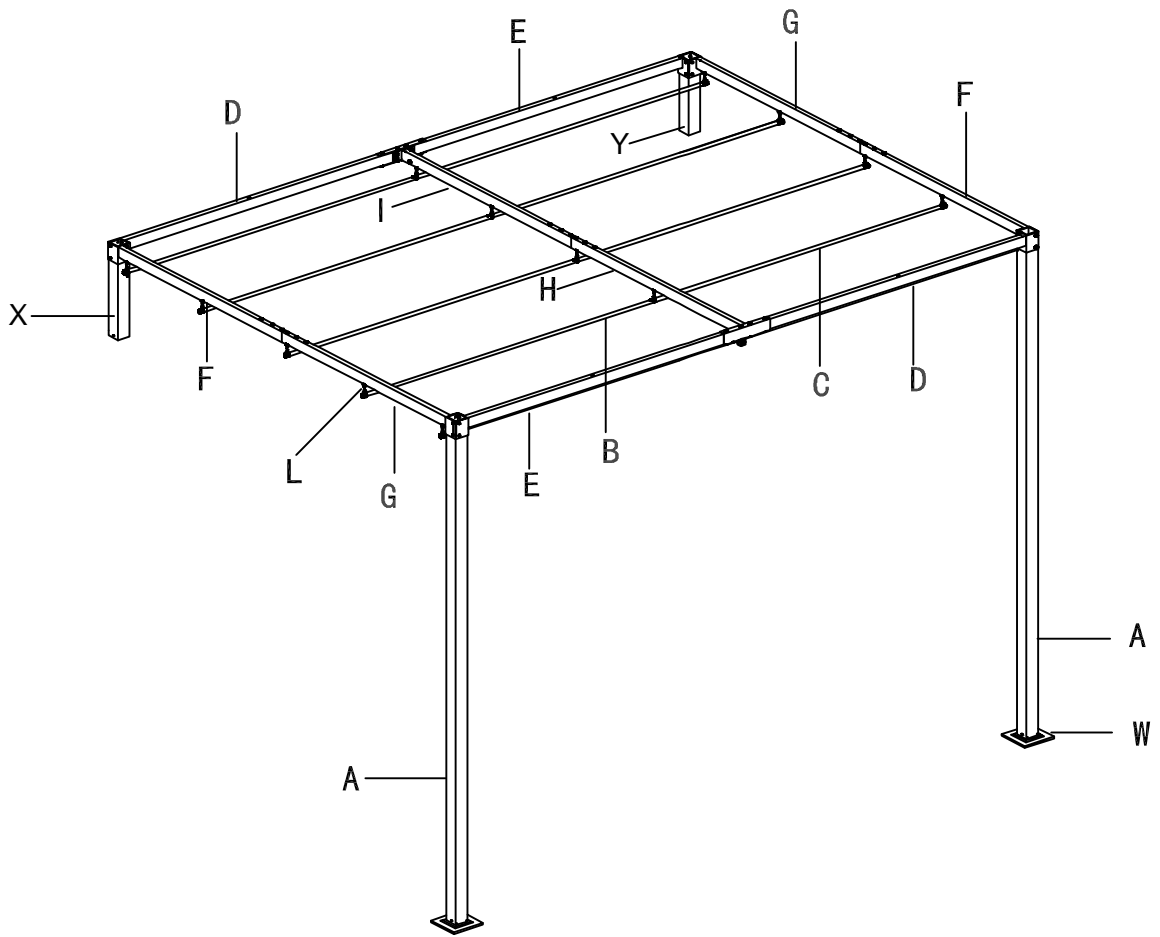

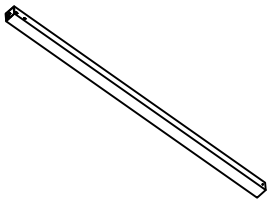
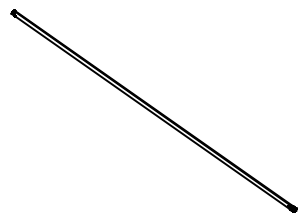
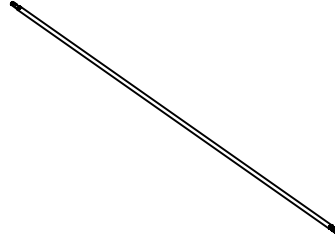
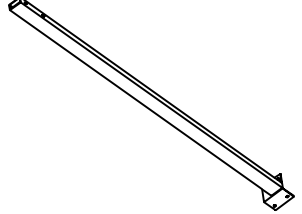
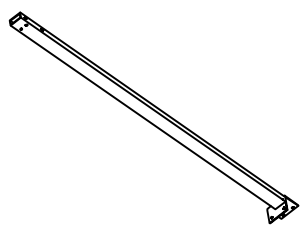
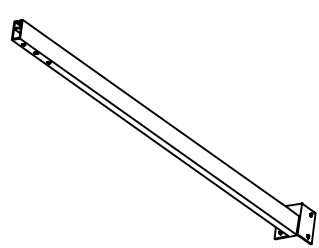
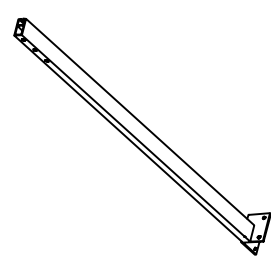

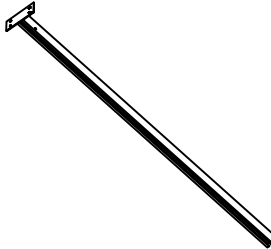
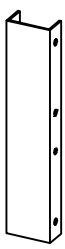
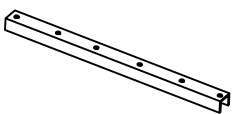
Alcune strutture possono richiedere due o più persone per essere installate in sicurezza.

Controlla le utenze sotterranee prima di scavare o piantare pali nel terreno!

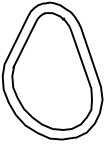
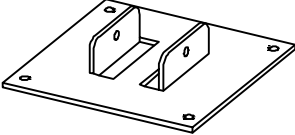
È importante che durante il montaggio vengano seguite attentamente le istruzioni, inoltre completare il montaggio su una superficie piana e solida e seguire le istruzioni per allineare, livellare e ancorare la struttura, in quanto questo ridurrà lo spazio necessario durante il montaggio.

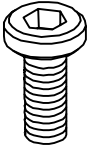
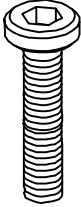
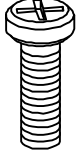
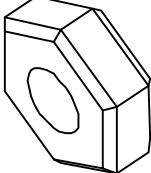
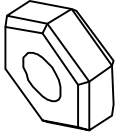

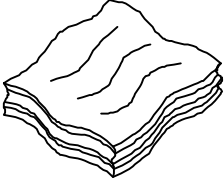
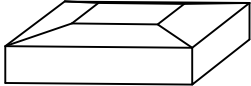
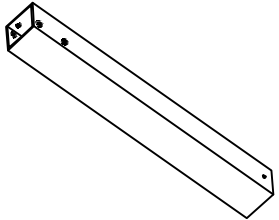
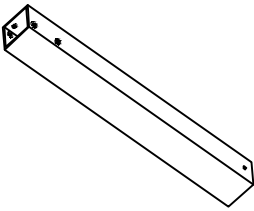
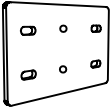
<p>Ax2</p> 	<p>Bx5</p> 	<p>Cx5</p> 	<p>Dx2</p> 
<p>Ex2</p> 	<p>Fx2</p> 	<p>Gx2</p> 	<p>Hx1</p> 
<p>Ix1</p> 	<p>Jx2</p> 	<p>Kx3</p> 	<p>Lx15</p> 

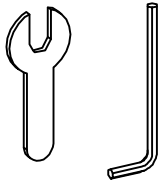
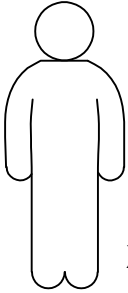
<p>Mx15</p> 	<p>Nx2</p> 	<p>Ox12</p> 	<p>Px66</p>  <p>M6*15</p>
<p>Qx8</p>  <p>M6*65</p>	<p>Rx1</p>  <p>M4*28</p>	<p>Sx8</p>  <p>M6</p>	<p>Tx1</p>  <p>M4</p>
<p>Ux66</p> 	<p>Vx1</p> 	<p>Wx2</p> 	<p>Xx1</p> 
<p>Yx1</p> 	<p>Zx2</p> 	<p>①x4</p> 	
 <p>mm inch</p> <p>x2</p>			

Dx1
Fx1
Lx5
Px8
Ux8
Xx1

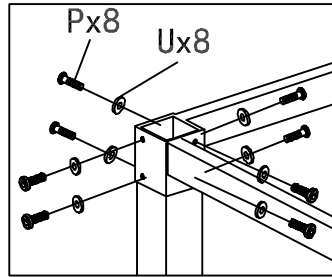
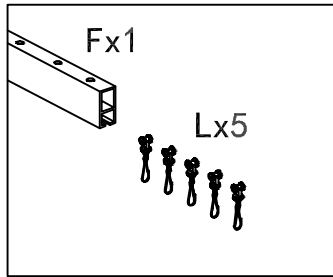
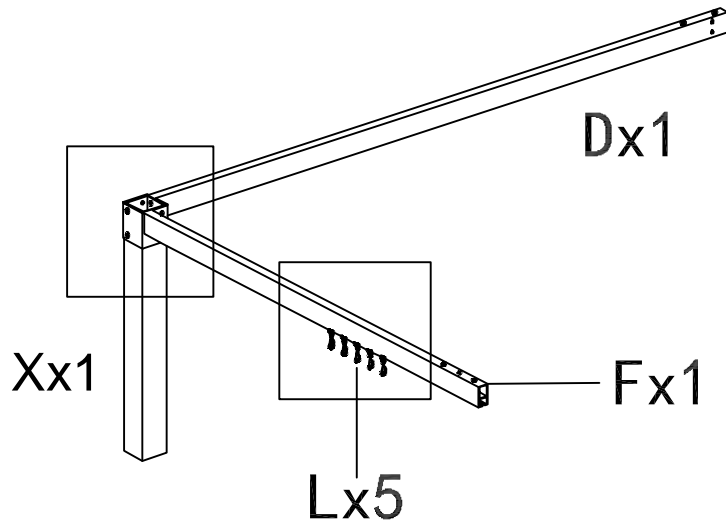

Ex1
Gx1
Lx5
Px8
Ux8
Yx1

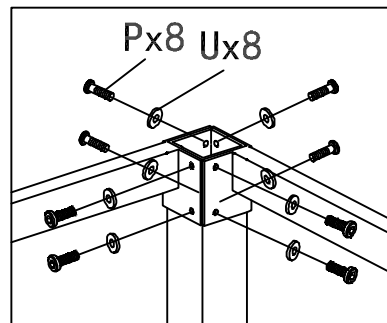
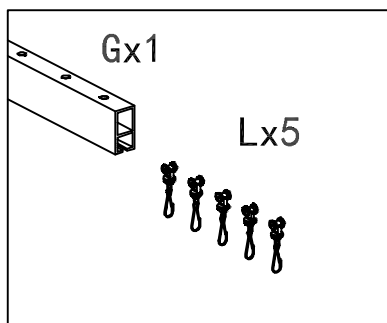
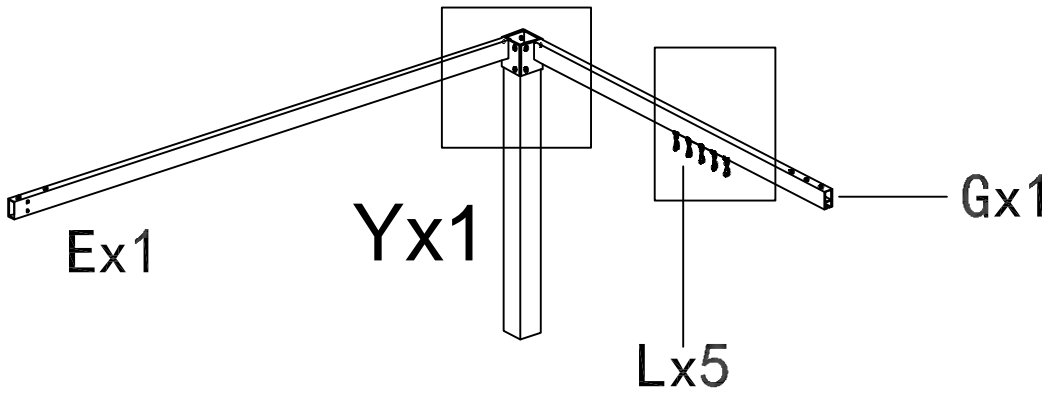

Gx1
Ex1
Ax1
Kx1
Px11
Ux11

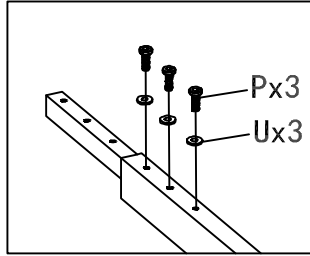
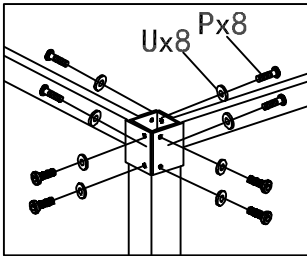
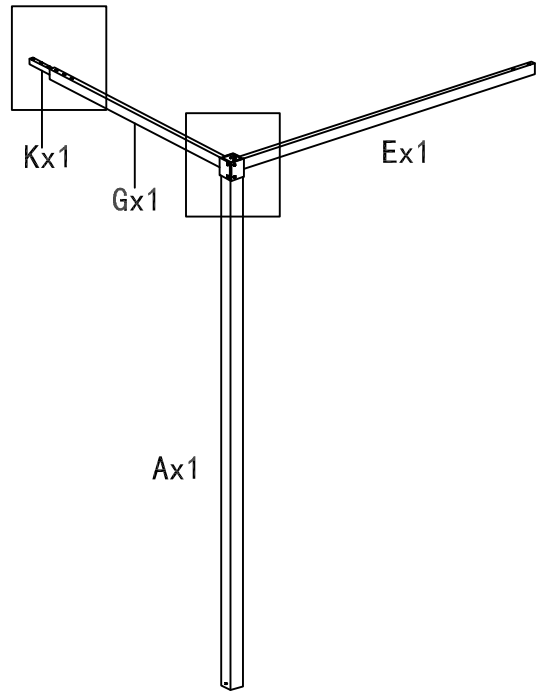

Fx1
Dx1
Kx1
Ax1
Px11
Ux11

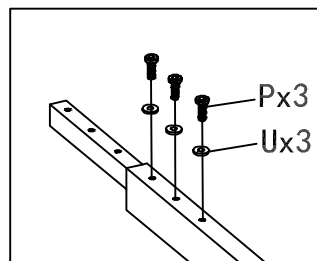
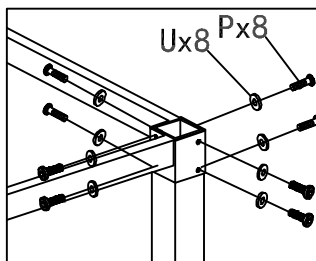
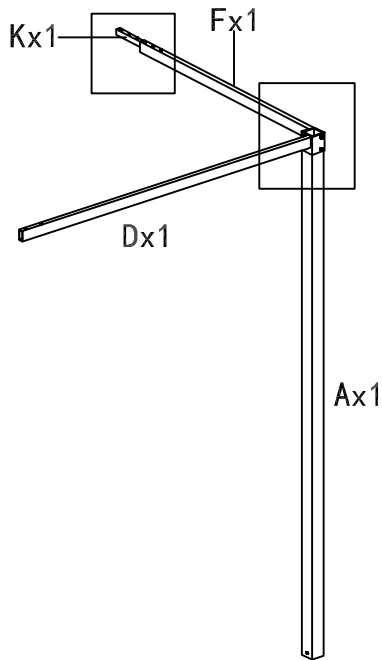

Px3
Ux3

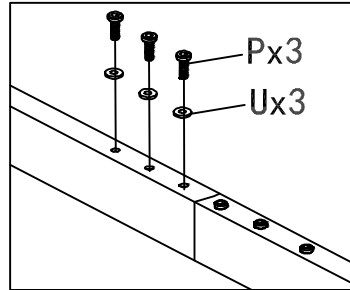
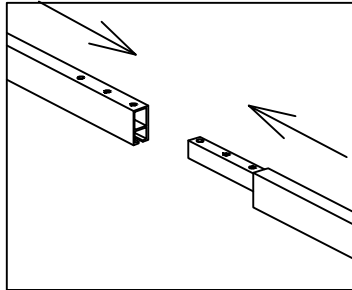
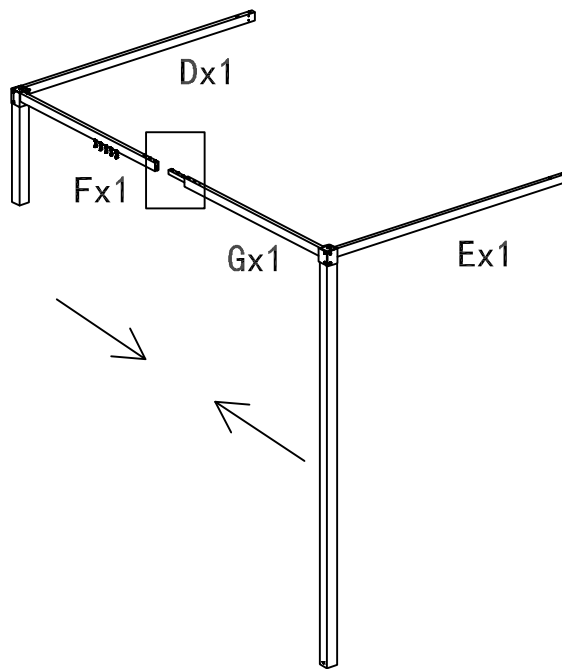

Px3
Ux3

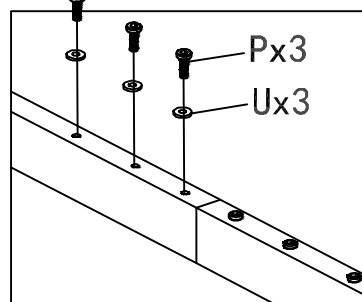
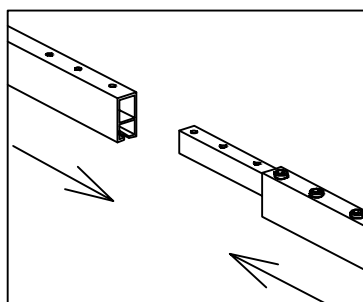
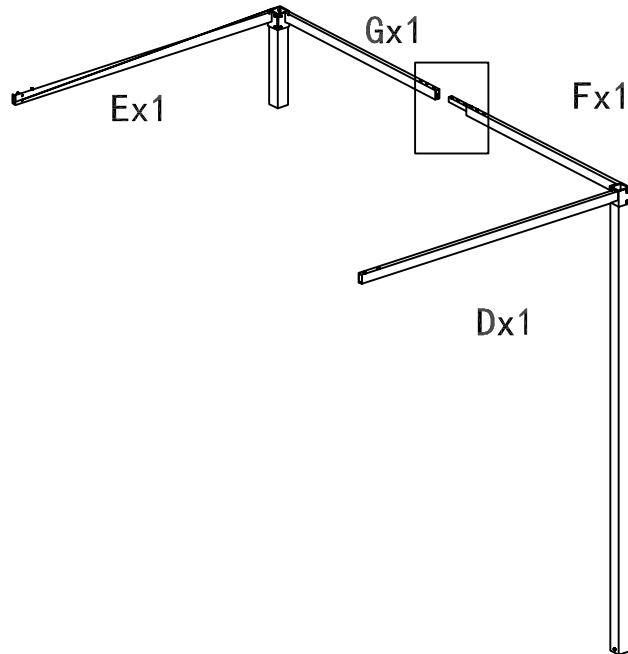

Qx8
Sx8
Jx2

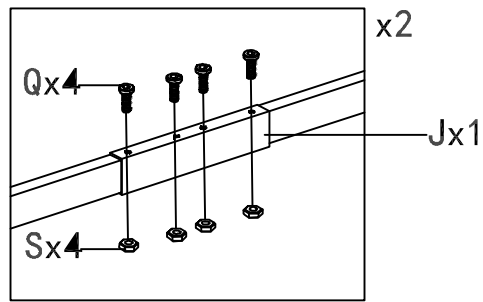
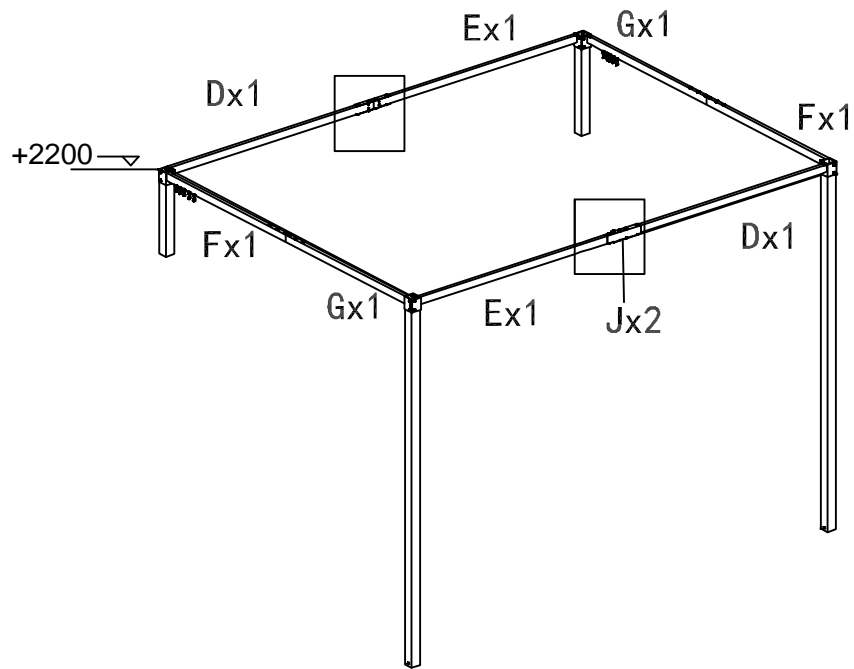

Ix1
Kx1
Lx1
Tx1
Rx1
Px3
Ux3

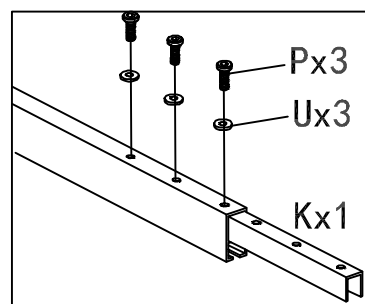
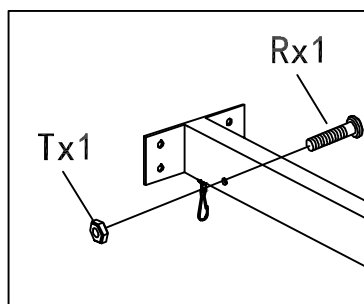
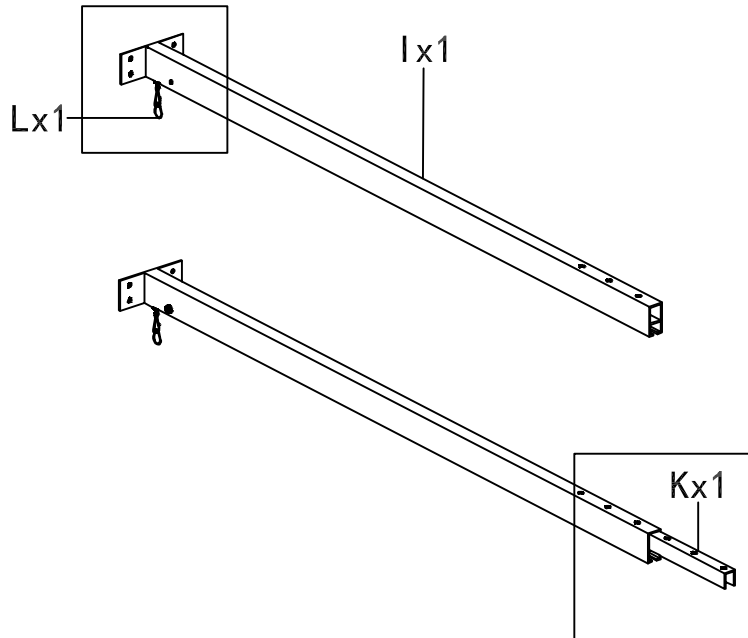

Hx1
Lx4
Px3
Ux3

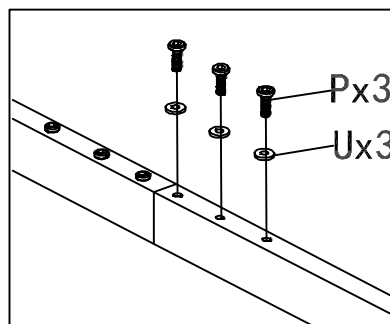
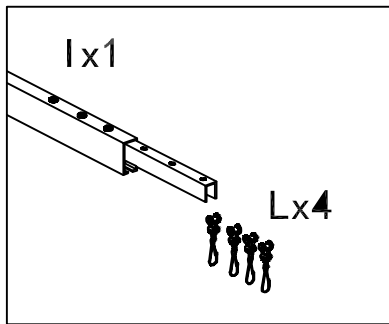
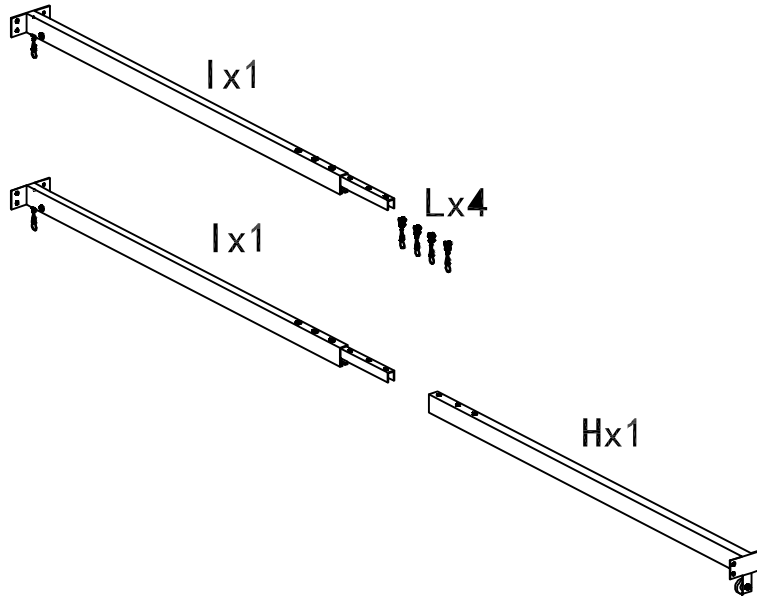

Px8
Ux8

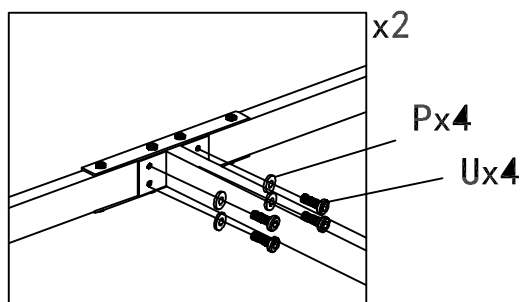
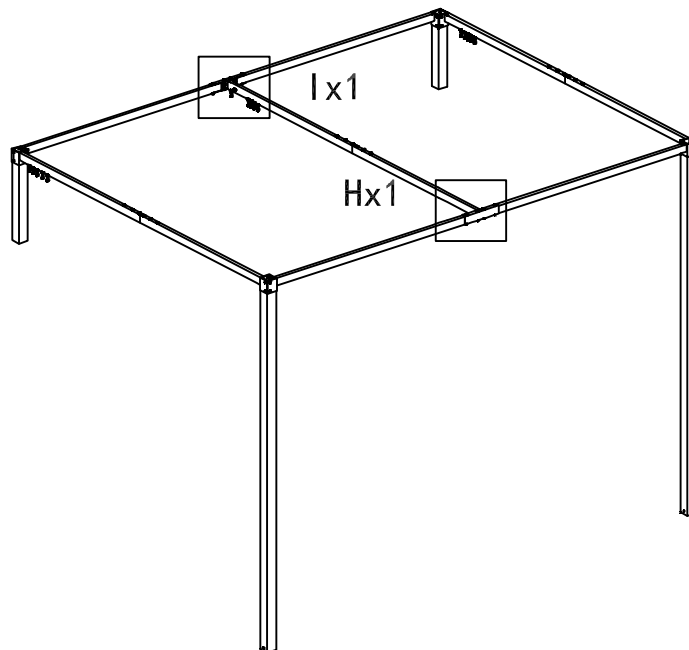

Bx5
Cx5
Mx10

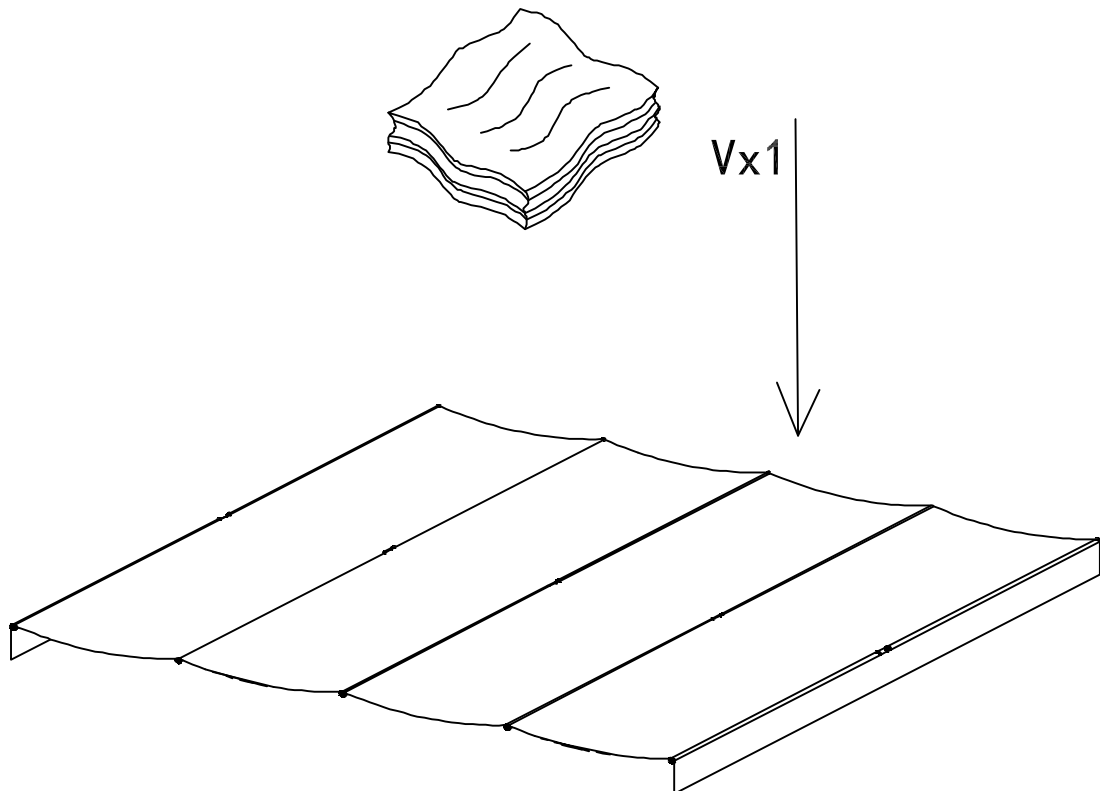
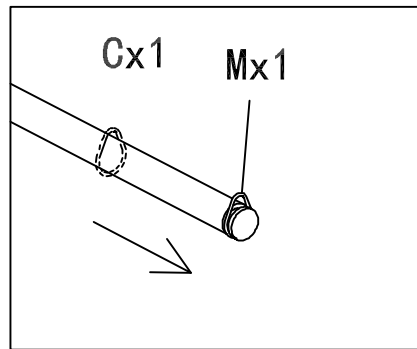
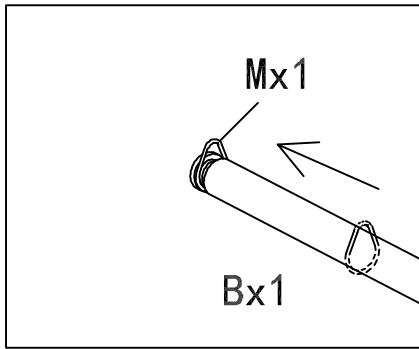
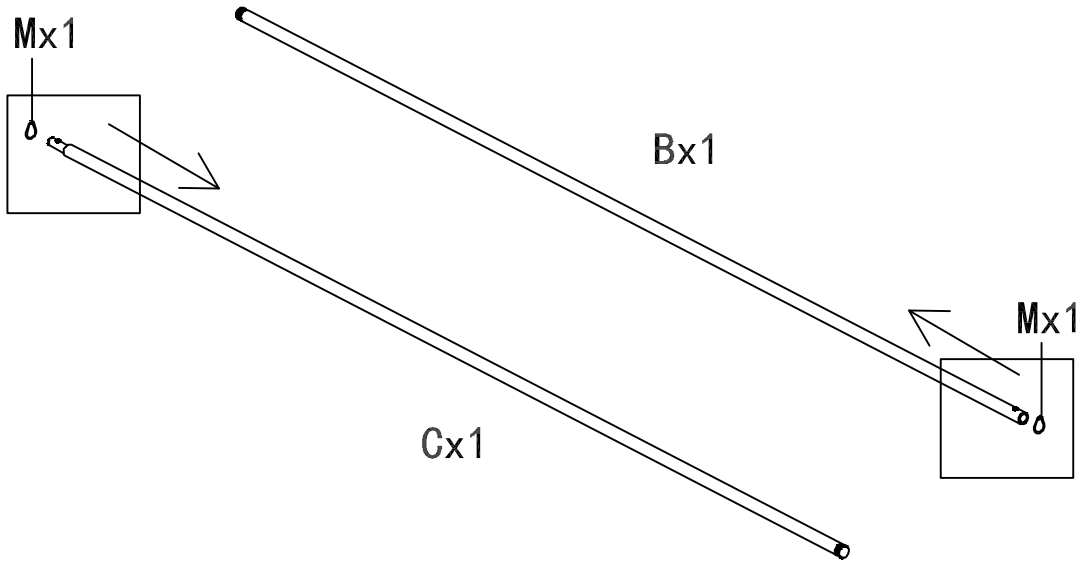

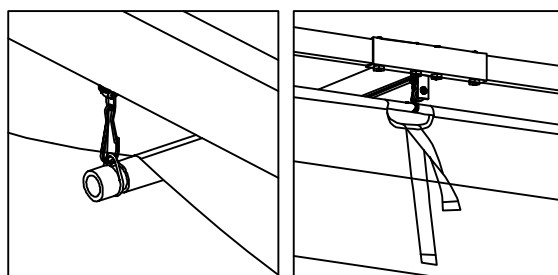
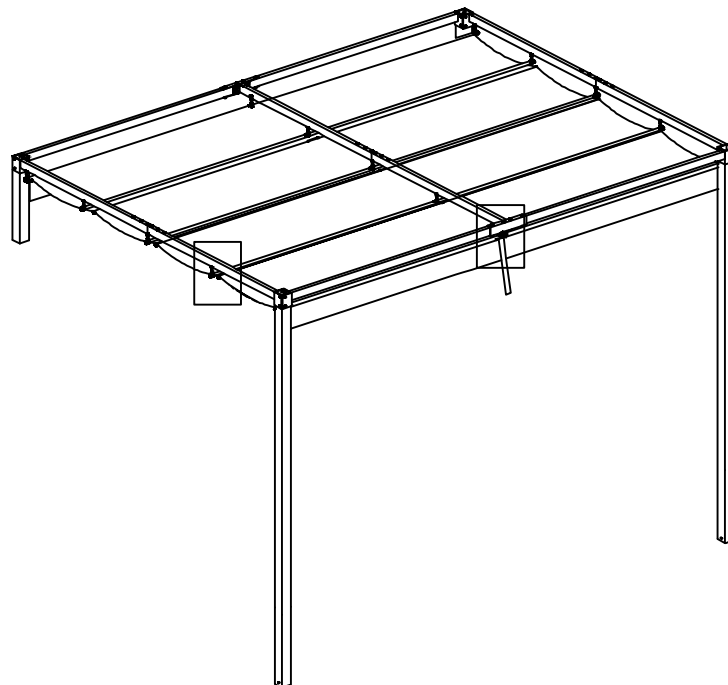
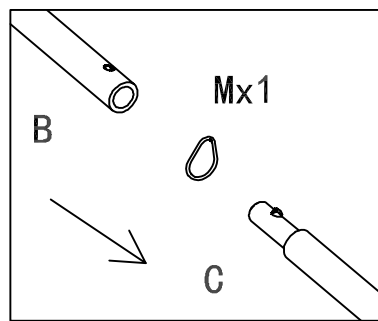
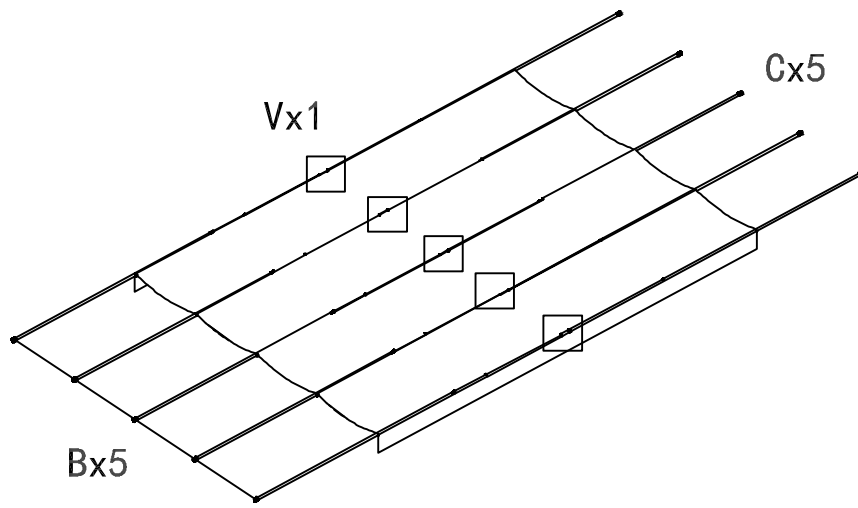

- Nx2
- Px4
- Ux4
- Ox4
- Wx2
- ①x4

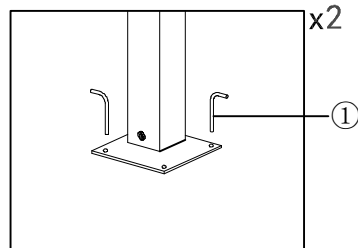
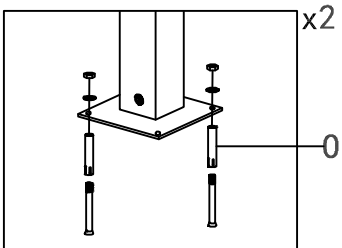
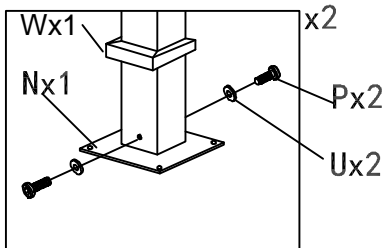
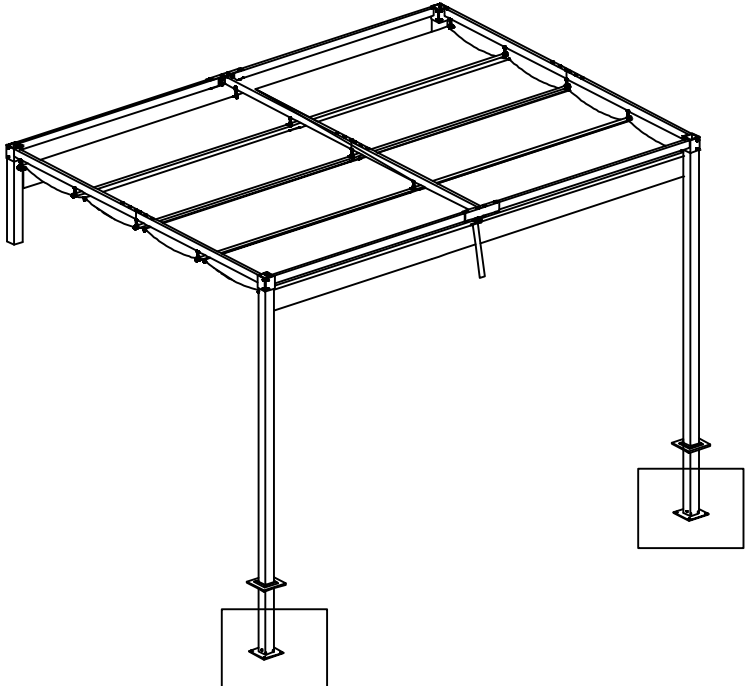

- Ox8
- Px4
- Ux4
- Zx2

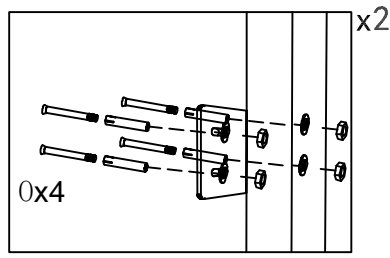
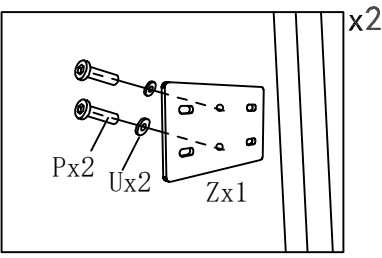
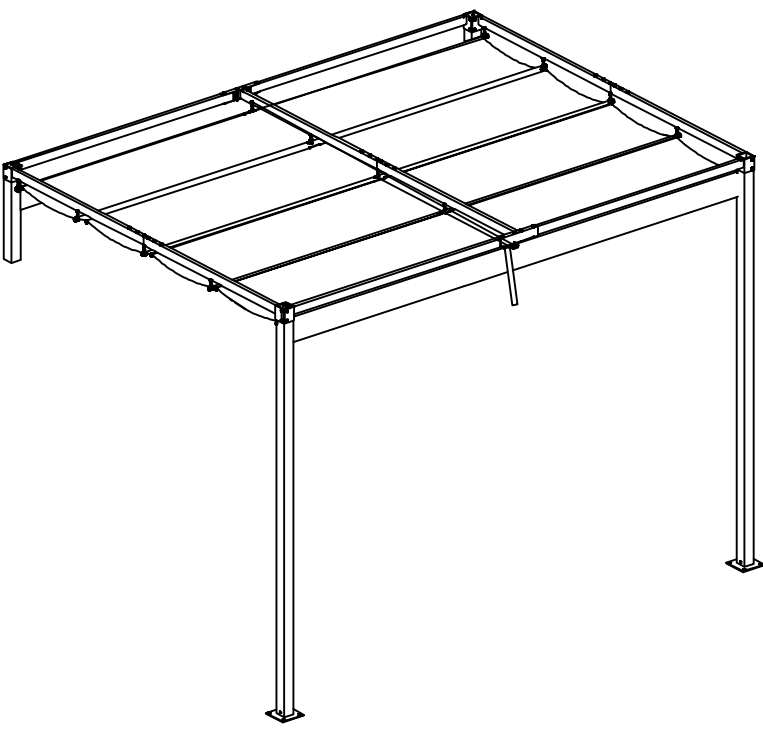

If you have any questions, please contact our customer care center, Our contact details are below:

US

 001-877-644-9366

 customerservice@aosom.com

Imported by Aosom LLC
27150 SW Kinsman Rd Wilsonville, OR 97070 USA
MADE IN CHINA

Wenn Sie Fragen haben, wenden Sie sich bitte an unser Kundendienstzentrum, Unsere Kontaktdaten stehen unten:

DE

 0049-0(40)-88307530

 service@aosom.de

ADRESSE DES IMPORTEURE/Hersteller/REP:
MH Handel GmbH
Wendenstraße 309
D-20537 Hamburg
Germany
IN CHINA HERGESTELLT

If you have any questions, please contact our customer care center, Our contact details are below:

CA

 416-792-6088

 customerservice@aosom.ca

Imported by Aosom Canada Inc.
7270 Woodbine Avenue, Unit 307, Markham,
Ontario Canada L3R 4B9
MADE IN CHINA

Si vous avez la moindre question, veuillez contacter notre centre d'assistance à la clientèle, Nos coordonnées sont les suivantes:

 416-792-6088

 customerservice@aosom.ca

Importé par Aosom Canada Inc.
7270 Woodbine Avenue, unité 307,
Markham, Ontario Canada L3R 4B9
FABRIQUÉ EN CHINE

In caso di dubbio, si prega di contattare il nostro centro assistenza clienti, I nostri dettagli di contatto sono di seguito:

IT

 0039-0249471447

 clienti@aosom.it

IMPORTATO DA/Produttore/REP:
AOSOM Italy srl
Centro Direzionale Milanofiori
Strada 1 Palazzo F1
20057 Assago (MI)
P.I.: 08567220960
FATTO IN CINA

Si tiene alguna pregunta, comuníquese con nuestro Centro de Atención al Cliente, Nuestros datos de contacto son los siguientes:

ES

 0034-931294512

 atencioncliente@aosom.es

IMPORTADOR/Fabricante/REP:
SPANISH AOSOM, S.L.
C/ROC GROS, N°15.08550, ELS HOSTALETES DE
BALENYÀ, SPAIN.
B66295775
HECHO EN CHINA

If you have any questions, please contact our customer care center, Our contact details are below:

UK

 0044-800-240-4004

 enquiries@mhstar.co.uk

IMPORTER ADDRESS:
MH STAR UK LTD
Unit 27, Perivale Park,
Horsenden lane South
Perivale, UB6 7RH
MADE IN CHINA

Se tiver alguma dúvida, por favor contacte o nosso Centro de Atendimento ao Cliente, Os nossos dados de contacto são os seguintes:

PT

 0034-931294512

 info@aosom.pt.

IMPORTADOR/Fabricante/REP:
SPANISH AOSOM, S.L.
C.ROC GROS N.15, 08550. ELS HOSTALETES DE
BALENYÀ
FEITO NA CHINA

Si vous avez la moindre question, veuillez contacter notre centre d'assistance à la clientèle, Nos coordonnées sont les suivantes:

FR

 0033-1-84166106

 aosom@mhfrance.fr

Importé par/Fabricant/REP:
MH FRANCE
2 Rue Maurice Hartmann
92130 Issy Les Moulineaux
France
FABRIQUÉ EN CHINE



FR

**DONNEZ
OU
RECYCLEZ**



ASSOCIATION

OU



LIVRAISON

OU



DÉCHÈTERIE

Adresses sur quefairedemesdechets.fr

US

Imported by Aosom LLC
27150 SW Kinsman Rd Wilsonville, OR 97070 USA
MADE IN CHINA

CA

Imported by Aosom Canada Inc.
7270 Woodbine Avenue, Unit 307, Markham, Ontario Canada
L3R 4B9
MADE IN CHINA

Importé par Aosom Canada Inc.
7270 Woodbine Avenue, unité 307, Markham, Ontario Canada
L3R 4B9
Fabriqué en Chine

UK

IMPORTER ADDRESS:
MH STAR UK LTD
Unit 27, Perivale Park,
Horsenden lane South
Perivale, UB6 7RH
MADE IN CHINA

FR

ADRESSE D'IMPORTATION:
MH FRANCE
2 Rue Maurice Hartmann
92130 Issy Les Moulineaux
France
FABRIQUÉ EN CHINE



Adresses sur quefairedemesdechets.fr

ES

IMPORTADOR:
SPANISH AOSOM, S.L.
C/ROC GROS, Nº15.08550, ELS HOSTALET DE BALENYÀ, SPAIN.
B66295775
WWW.AOSOM.ES
ATENCIONCLIENTE@AOSOM.ES
TEL: 931294512
HECHO EN CHINA

PT

SPANISH AOSOM, S.L
C.ROC GROS N.15, 08550. ELS HOSTALET DE BALENYÀ
TEL: 931294512 (SEG-SEX DAS 7:30H ÀS 16:30H)
INFO@AOSOM.PT
WWW.AOSOM.PT

DE

ADRESSE DES IMPORTEURS:
MH Handel GmbH
Wendenstraße 309
D-20537 Hamburg
Germany
IN CHINA HERGESTELLT

IT

IMPORTATO DA:
AOSOM Italy srl
Centro Direzionale Milanofiori
Strada 1 Palazzo F1
20057 Assago (MI)
P.I.: 08567220960
FATTO IN CINA



Mounting on a concrete wall

The awnings must be installed at least at the thickness of 10cm only on a reinforced concrete wall. If the wall shows cracks you have to consult a professional.



The maximum load for the non-retractable parts of the awning: 680N

Tools Recommended:

Chopping bit Ø10mm 

HARDWARE:

Ox12
M6*50

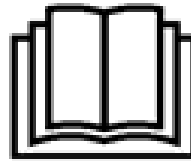

Storage

When it is unused for a long time, it is suggested to take the awning out of the mounting bracket, and properly store it.

- Before storage, ensure that the tarpaulin is completely dry, so as to prevent mildew and adhesion, and prevent permanent fatigue of waterproof adhesive tape in bending, and extend the service life of awning
- Attention! At least Three healthy adults are needed for this step.
- Remove the awning by above step of mounting instructions in reversed order.
- Retract the awning completely.
- Store the awning in a dry and safe place away from children.

Maintenance

Maintenance can extend the service life of the awning.

- Check whether the bolts are loose once a month; please tighten if loose bolts and nuts are found
- If it is damaged or not properly tightened, please immediately stop using the Pergola awning
- Clean once a month to keep the appearance clean
- After cleaning the tarpaulin, check the tightness of the fabric.
- Under normal circumstances, awning does not need lubrication. If there is abnormal noise or hard contraction, please use plastic lubricant, and do not use petroleum-based lubricant.
- Avoid leaving frozen ice on awning, or it is easy to damage the sunshade cloth and cause needless loss.
- If problems occur in the process of using, please contact the authorized center for inspection and maintenance.

Wind resistance class

The awning is rated Wind Class 1 when firmly anchored with the correct mounting material and must be retracted immediately at wind speeds of 28 km/h and above.

Wind Class 1

Speed 20-28 km/h = 5.5-7.9 m/s.

Disposal:

The same as the installation steps; three adults with professional skills are needed; the disassembly is opposite to the installation.

At the end of your item's long service life, please dispose of the valuable raw materials properly so that proper recycling can take place. If you are not sure how best to proceed, the local waste disposal companies or recycling centre will be happy to help.



IN230900085V01_GL

84C-470V00

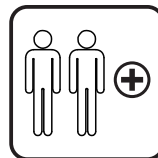
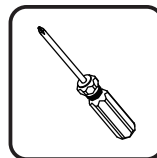
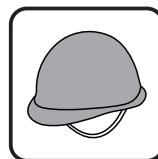
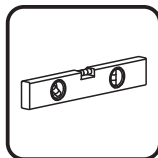
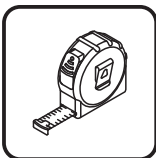
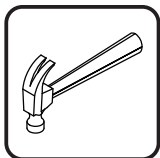
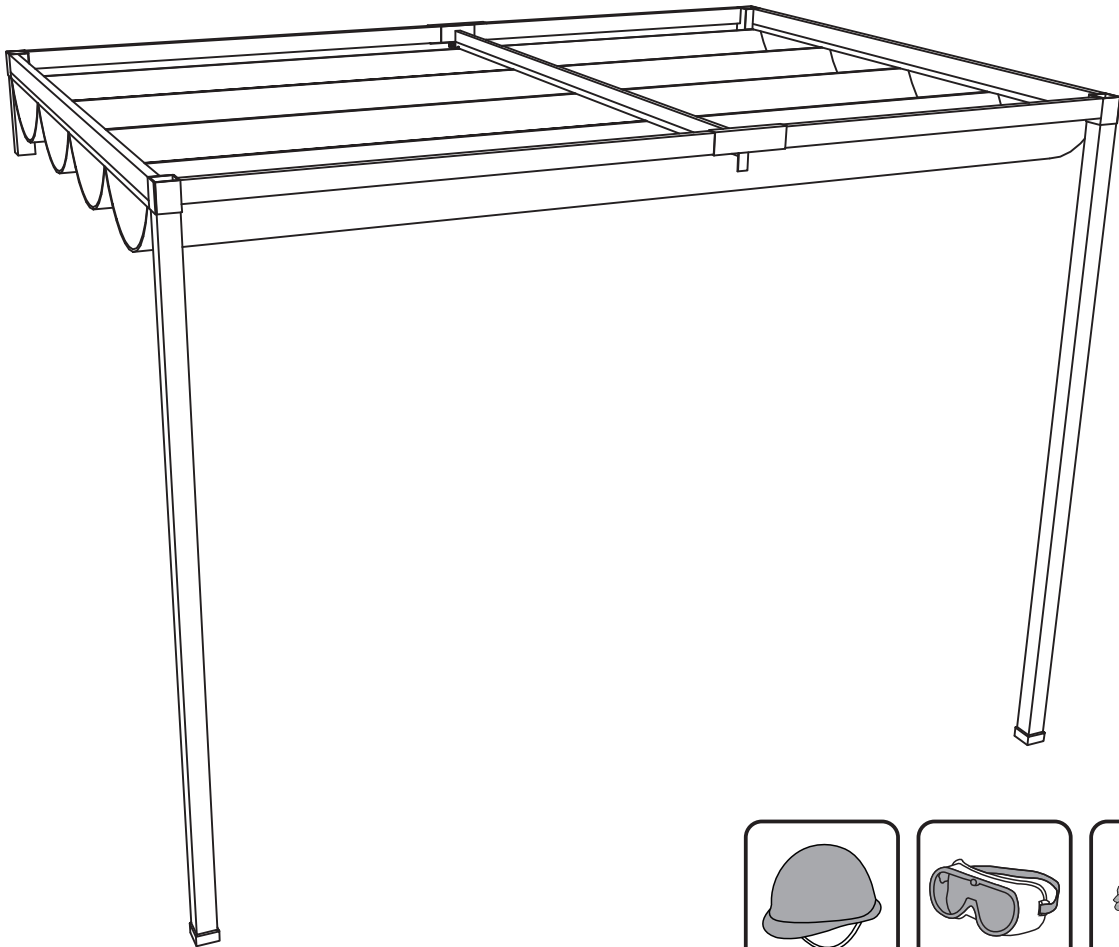

Tools Recommended

EN_ IMPORTANT, RETAIN FOR FUTURE REFERENCE: READ CAREFULLY.

FR_ IMPORTANT: A LIRE ATTENTIVEMENT ET À CONSERVER POUR CONSULTATION ULTÉRIEURE.

ES_ IMPORTANTE, LEA Y GUARDE PARA FUTURAS REFERENCIAS.

PT_ IMPORTANTE, RETER PARA REFERÊNCIA FUTURA: LEIA ATENTAMENTE.

DE_ WICHTIG! SORGFÄLTIG LESEN UND FÜR SPÄTER NACHSCHLAGEN AUFBEWAHREN.

IT_ IMPORTANTE! CONSERVARE IL PRESENTE MANUALE PER FUTURO RIFERIMENTO E LEGGERLO ATTENTAMENTE.

EN

Dear customer,

Thank you for purchasing this product. So that your appliance serves you well, please read all the instructions in this user's manual. If you have any questions, please contact our customer care center, Our contact details are below:

FR

Cher client,

Nous vous remercions d'avoir acheté ce produit. Afin que vous puissiez profiter pleinement de votre appareil, veuillez lire toutes les instructions de ce manuel d'utilisation. Si vous avez la moindre question, veuillez contacter notre centre d'assistance à la clientèle, Nos coordonnées sont les suivantes:

DE

Sehr geehrter Kunde,

Vielen Dank, dass Sie dieses Produkt erworben haben. Damit Ihr Gerät Ihnen gute Dienste leistet, lesen Sie bitte alle Hinweise in diesem Benutzerhandbuch. Wenn Sie Fragen haben, wenden Sie sich bitte an unser Kundendienstzentrum, Unsere Kontaktdaten stehen unten:

ES

Queridos clientes,

Gracias por comprar este producto. Para que su electrodoméstico le sirva mejor, lea todas las instrucciones de este manual del usuario. Si tiene alguna pregunta, comuníquese con nuestro Centro de Atención al Cliente, Nuestros datos de contacto son los siguientes:

PT



Caros clientes,

Obrigado por adquirir este produto. Para que o seu aparelho o sirva melhor, leia todas as instruções deste manual do utilizador. Se tiver alguma dúvida, por favor contacte o nosso Centro de Atendimento ao Cliente, Os nossos dados de contacto são os seguintes:

IT

Caro Cliente,

Grazie per aver acquistato questo prodotto. Per servirti meglio con questo apparecchio ti prego di leggere tutte le istruzioni in presente manuale utente. In caso di dubbio, si prega di contattare il nostro centro assistenza clienti, I nostri dettagli di contatto sono di seguito:

Country	 Phone	 Email
US	001-877-644-9366	customerservice@aosom.com
CA	416-792-6088	customerservice@aosom.ca
UK	0044-800-240-4004	enquiries@mhstar.co.uk
DE	0049-0(40)-88307530	service@aosom.de
FR	0033-1-84166106	aosom@mhfrance.fr
ES	0034-931294512	atencioncliente@aosom.es
PT	0034-931294512	info@aosom.pt
IT	0039-0249471447	clienti@aosom.it

EN

IMPORTANT SAFETY NOTICE

Product is NOT INTENDED for the following:

- A safety barrier to prevent unsupervised access to pools, hot tubs, spas or ponds.
- As load bearing support for a building, structure, heavy objects or swings.
- Used in structures that trap wind, rain or snow that would create extra load on the product.

Accumulated snow must be removed from roof.

DO NOT climb or walk on roof for any reason.

Wear gloves to avoid injury from possible sharp edges of individual elements before assembly.

During installation, follow all safety warnings provided with your tools.

Some structures may require two or more people to install safely.

Check for underground utilities before digging or driving stakes into the ground!

It is important during assembly to closely follow the instructions, complete the assembly on a solid level surface and that you follow the instruction to square up, level and anchor the structure, this will reduce the gap at connections during assembly.

FR

AVIS IMPORTANT DE SÉCURITÉ

Le produit n'est PAS DESTINÉ à ce qui suit :

- Une barrière de sécurité pour empêcher l'accès non surveillé aux piscines, aux spas, aux cuves thermales ou aux étangs.
- Comme support de charge pour un bâtiment, une structure, des objets lourds ou des balançoires.
- Utilisé dans des structures qui retiennent le vent, la pluie ou la neige qui créeraient une charge supplémentaire sur le produit.

La neige accumulée doit être enlevée du toit.

NE PAS grimper ou marcher sur le toit pour quelque raison que ce soit.

Portez des gants pour éviter les blessures causées par d'éventuels bords tranchants des composants avant de procéder à l'assemblage.

Lors de l'installation, respectez tous les avertissements de sécurité fournis avec vos outils.

Certaines structures peuvent nécessiter l'intervention de deux personnes ou plus pour les installer en toute sécurité.

Vérifiez la présence de services publics souterrains avant de creuser ou de planter des piquets dans le sol !

Il est important, pendant tout le processus de montage, de suivre attentivement les instructions, de terminer l'assemblage sur une surface solide et plane et de suivre les instructions d'équerrage, de mise à niveau et d'ancrage de la structure, ce qui permettra de réduire les écarts au niveau des liaisons pendant le montage.

ES

AVISO IMPORTANTE DE SEGURIDAD

Manténgase alejado de las líneas eléctricas aéreas.

No coloque ni instale su tienda de campaña debajo de los árboles debido a posibles rayos o hundimiento de las ramas de los árboles en condiciones climáticas adversas. Para obtener las mejores condiciones en caso de viento fuerte, coloque el extremo estrecho de la tienda en la dirección del viento.

No dejes caer la tienda de campaña.

No haga rebotar ni golpee la bolsa de la tienda para sacarla, estas acciones podrían dañar el marco.

ESTE PRODUCTO REQUIERE UN MÍNIMO DE DOS PERSONAS PARA SU MONTAJE

Bajo ninguna circunstancia se debe utilizar este producto para cubrir automóviles, vehículos marinos o artículos similares.

PRECAUCIÓN: Vigile no pellizcarse los dedos durante el montaje y desmontaje de la tienda al unir las piezas del marco.

AVISO DE SEGURANÇA IMPORTANTE

O produto NÃO é DESTINADO ao seguinte:

- Uma barreira de segurança para impedir o acesso sem supervisão a piscinas, banheiras, spas ou lagos.
- Como suporte de carga para um edifício, estrutura, objectos pesados ou baloiços.
- Usado em estruturas que apanham vento, chuva ou neve que criariam carga extra sobre o produto.

A neve acumulada deve ser removida do telhado. NÃO subir ou caminhar no telhado por qualquer razão.

Usar luvas para evitar ferimentos causados por possíveis arestas vivas de elementos individuais antes da montagem.

Durante a instalação, siga todos os avisos de segurança fornecidos com as suas ferramentas. Algumas estruturas podem exigir a instalação segura de duas ou mais pessoas. Verifique a existência de utilidades subterrâneas antes de escavar ou de conduzir estacas no solo!

É importante durante a montagem seguir de perto as instruções, completar a montagem numa superfície sólida e nivelar e ancorar a estrutura, o que reduzirá a folga nas ligações durante a montagem.

WICHTIGER SICHERHEITSHINWEIS

Das Produkt ist NICHT für einen der folgenden Anwendungen bestimmt:

- Als Sicherheitsbarriere, die den unbeaufsichtigten Zugang zu Pools, Whirlpools, Spas oder Teichen verhindert.
- Als tragende Stütze für ein Gebäude, eine Struktur, schwere Gegenstände oder Schaukeln.
- Als Bestandteil einer Struktur verwendet werden, welche Wind, Regen oder Schnee abfangen, die eine zusätzliche Belastung für das Produkt darstellen würden.

Angesammelter Schnee muss vom Dach entfernt werden.

Aus keinem Grund darf das Dach bestiegen oder betreten werden.

Bitte tragen Sie stets geeignete Arbeitshandschuhe, um Verletzungen durch mögliche scharfe Kanten einzelner Elemente während der Montage zu vermeiden.

Befolgen Sie während des Installationsprozesses bitte sorgfältig alle Sicherheitswarnungen, die mit Ihren Werkzeugen geliefert werden.

Einige Strukturen können zwei oder mehr Personen erfordern, um sicher installiert zu werden.

Prüfen Sie vor dem Graben oder Eintreiben von Pfählen in den Boden, ob Erdkabel vorhanden sind!

Es ist wichtig, während der Montage die Anweisungen genau zu befolgen, Ihr Produkt auf einem festen und ebenen Untergrund aufzustellen und die Anweisung zum Aufrichten, Nivellieren und Verankern der Struktur zu befolgen, da dadurch der Spalt an den Verbindungen während der Montage verringert wird.

IMPORTANTI PRECAUZIONI DI SICUREZZA

Il prodotto NON è PROGETTATO per quanto segue:

- Una barriera di sicurezza per impedire l'accesso senza supervisione a piscine, vasche idromassaggio, spa o stagni.
- Supporto portante di edifici, strutture, oggetti pesanti o altalene.
- Parte di strutture che accumulano vento, pioggia o neve, in quanto creerebbero un carico extra sul prodotto.

La neve accumulata deve essere rimossa dal tetto.

NON salire o camminare sul tetto per nessun motivo.

Indossare guanti per evitare lesioni derivanti da spigoli vivi dei singoli componenti prima del montaggio.

Durante l'installazione, seguire tutte le precauzioni di sicurezza fornite con gli strumenti.

Alcune strutture possono richiedere due o più persone per essere installate in sicurezza.

Controlla le utenze sotterranee prima di scavare o piantare pali nel terreno!

È importante che durante il montaggio vengano seguite attentamente le istruzioni, inoltre completare il montaggio su una superficie piana e solida e seguire le istruzioni per allineare, livellare e ancorare la struttura, in quanto questo ridurrà lo spazio necessario durante il montaggio.

PARTS

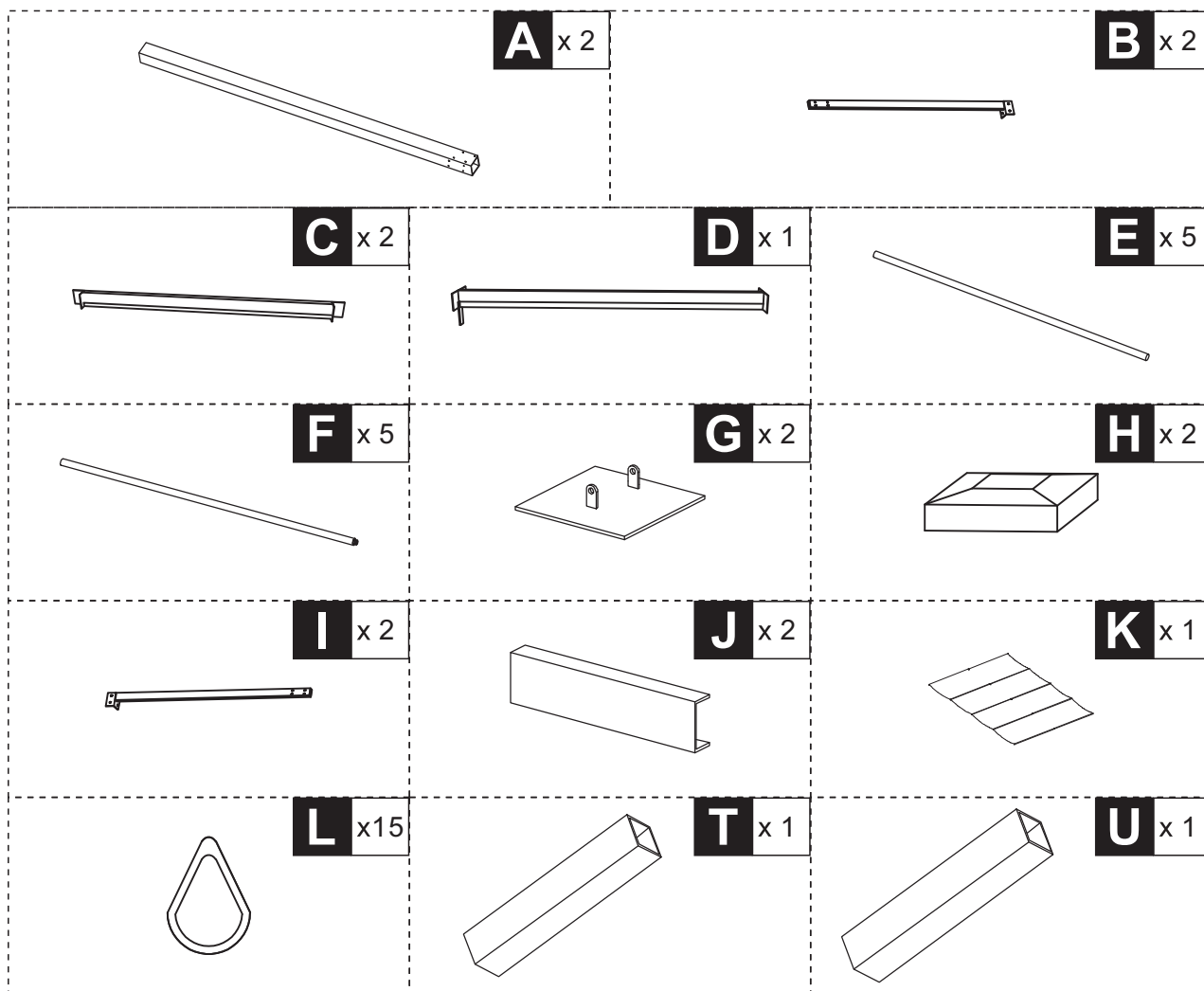

HARDWARE

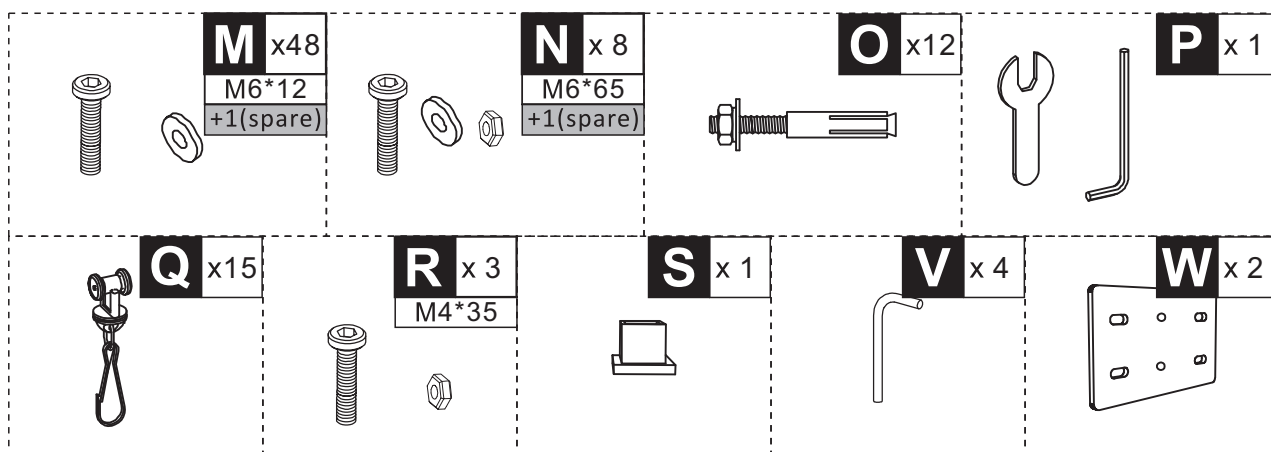

NOTE

EN_ Do not confuse similar screws.
FR_ Ne pas confondre des vis similaires.
ES_ No confunda tornillos similares.
PT_ Não confundir parafusos semelhantes.
DE_ Verwechseln Sie ähnliche Schrauben nicht.
IT_ Non confondere le viti simili.

01

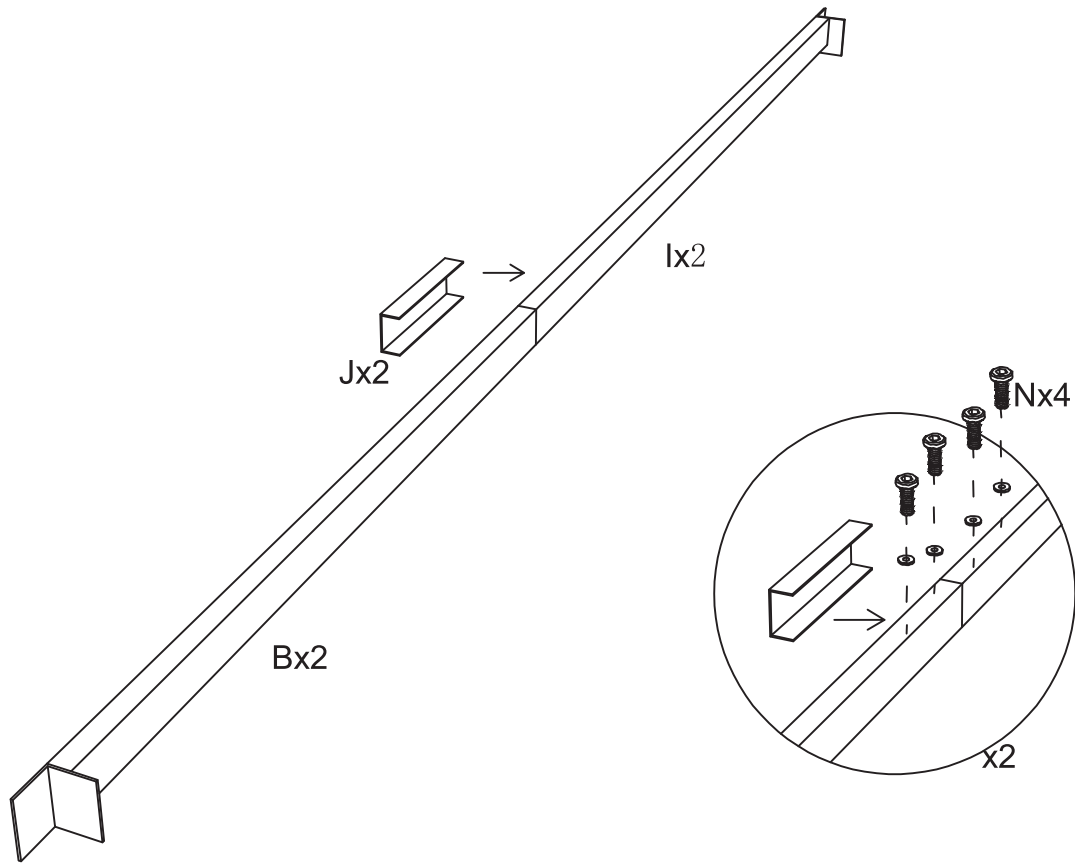
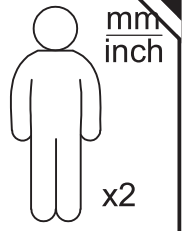

N x8

02

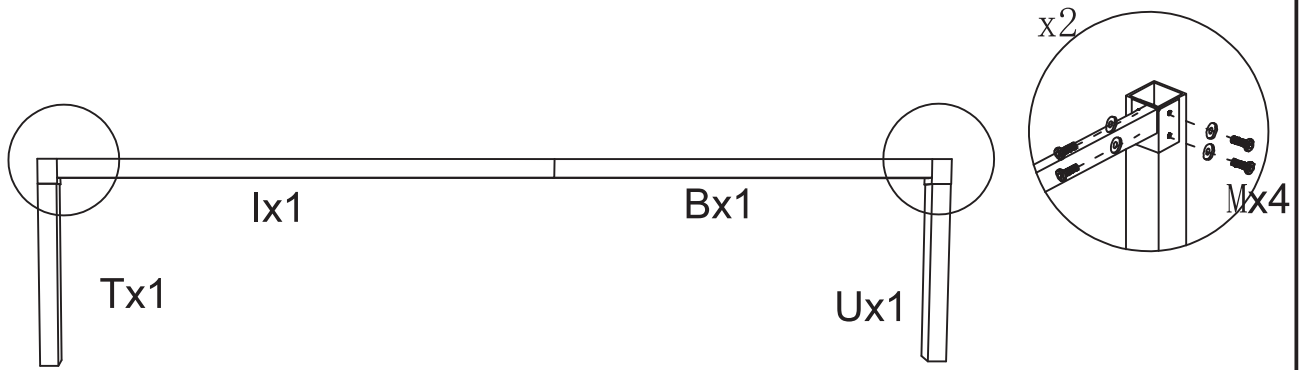

M x8

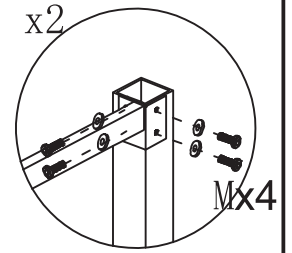
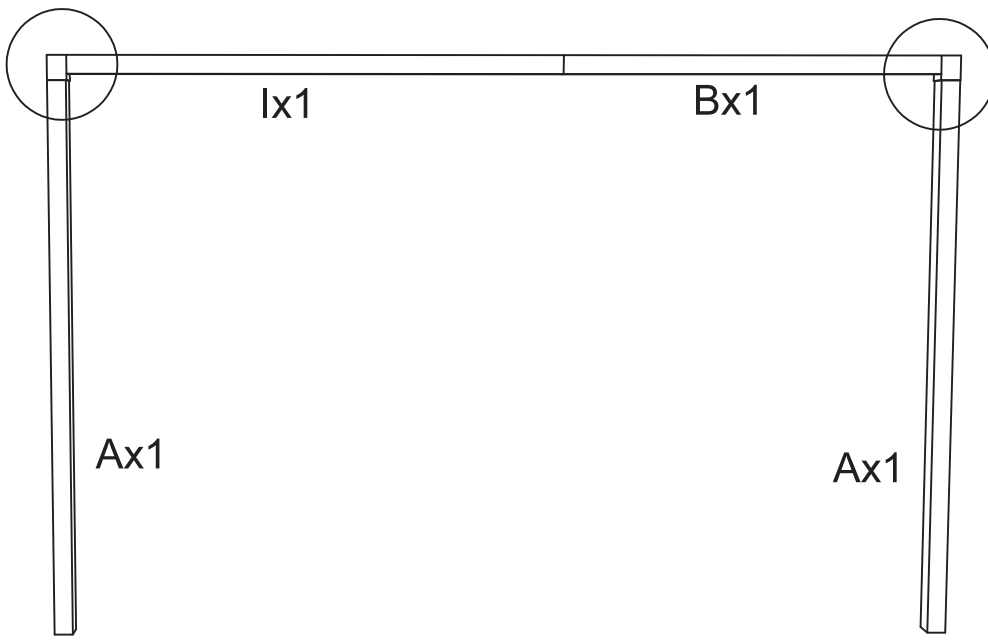

M x8

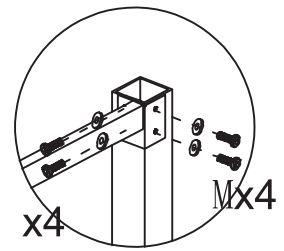
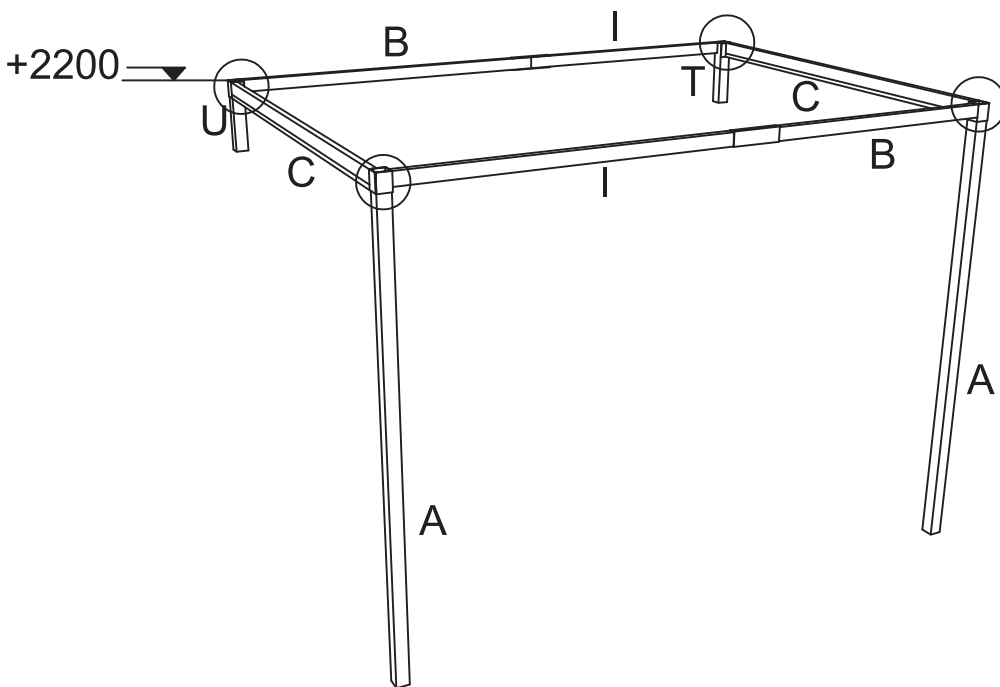

M x16

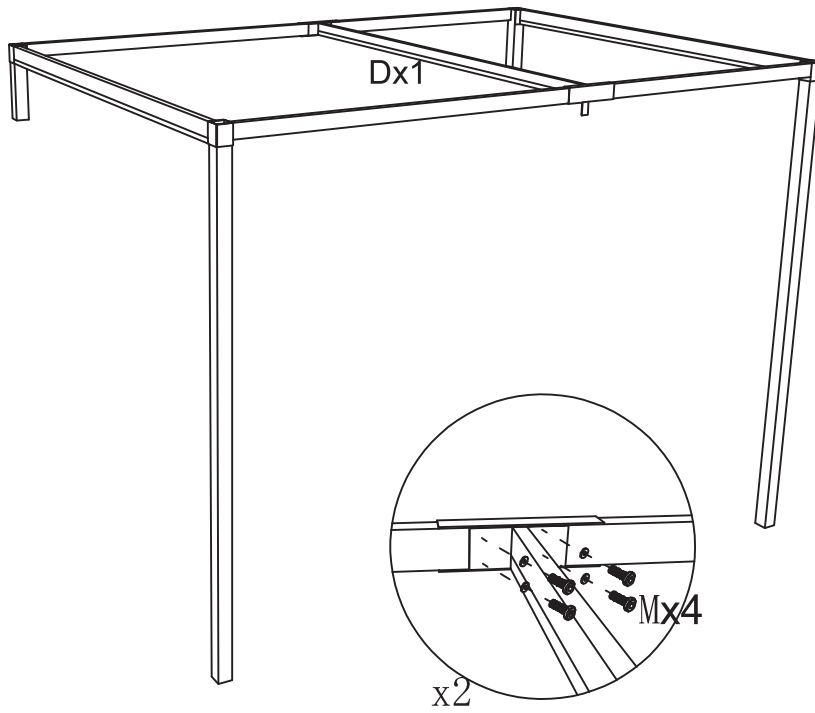

M x8

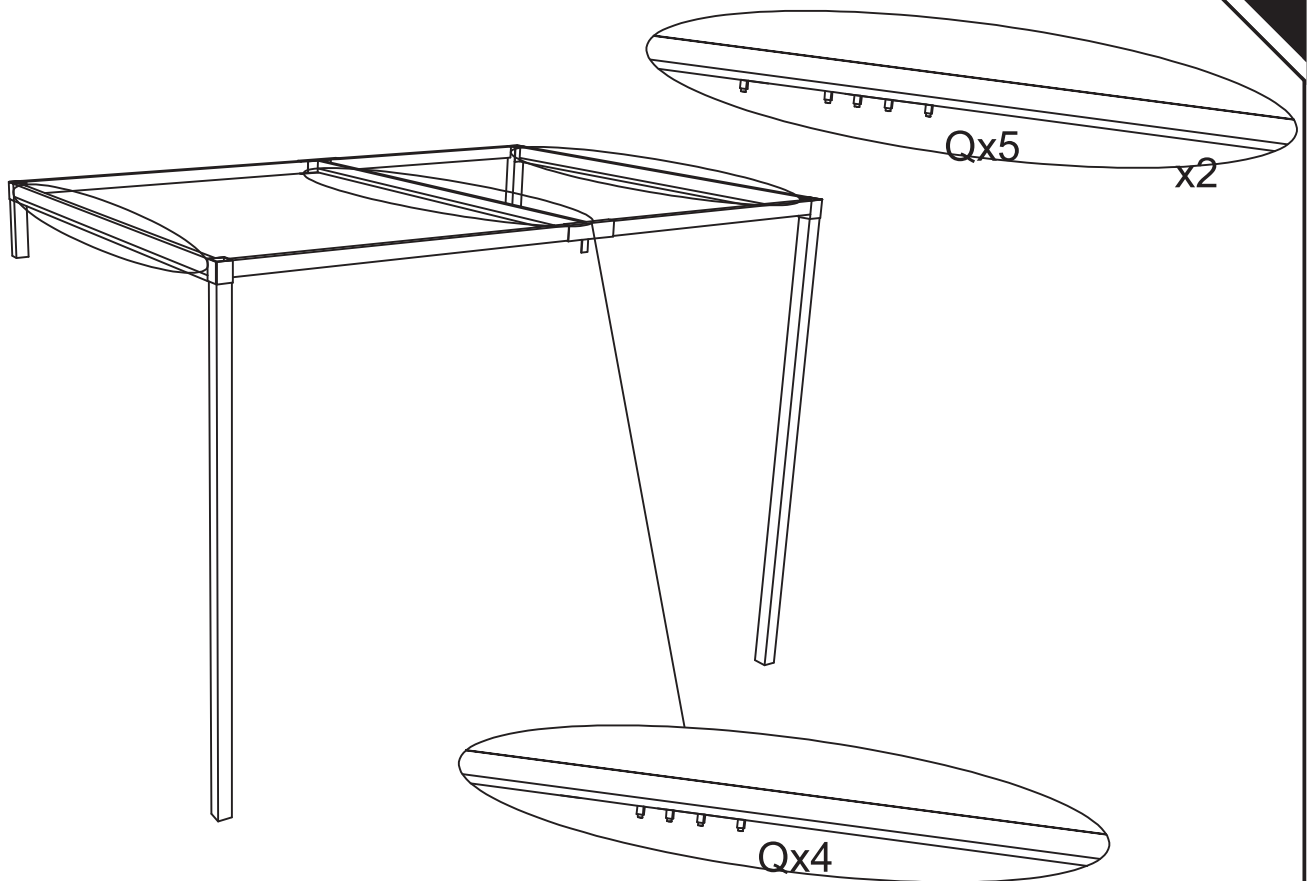

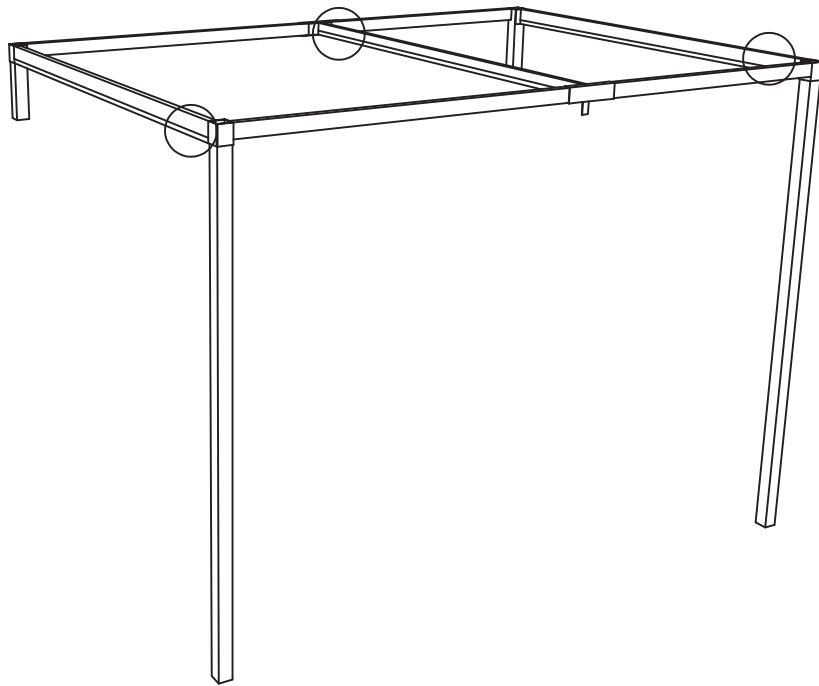

R x3

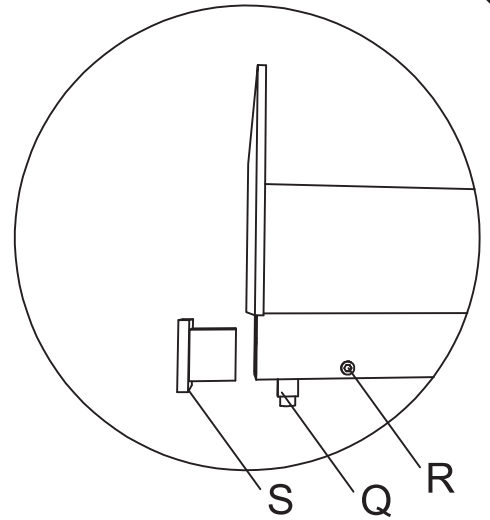
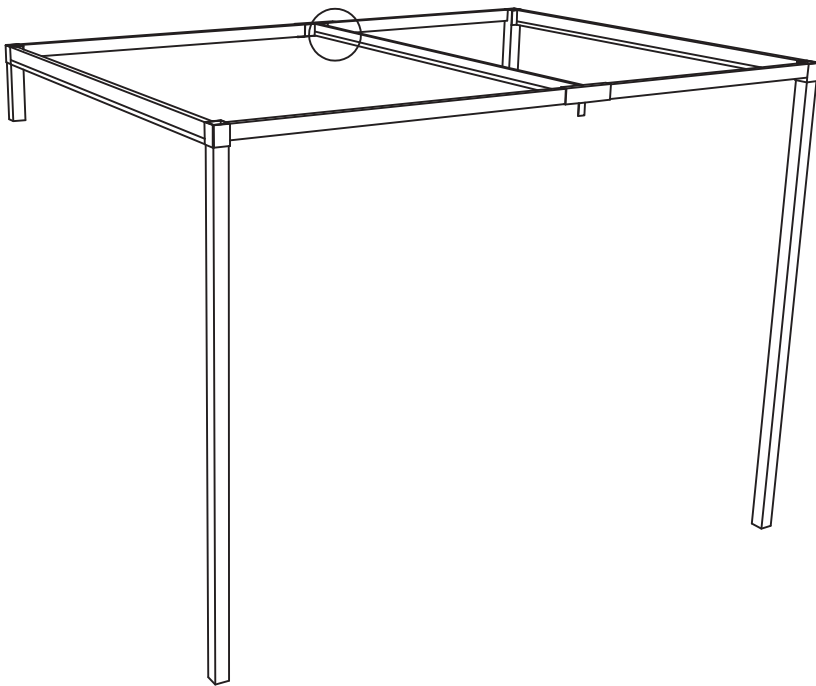

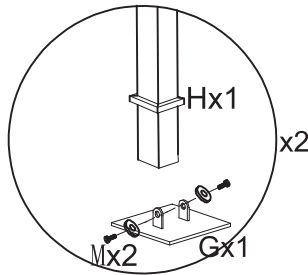
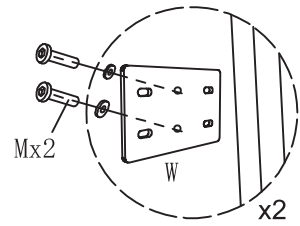
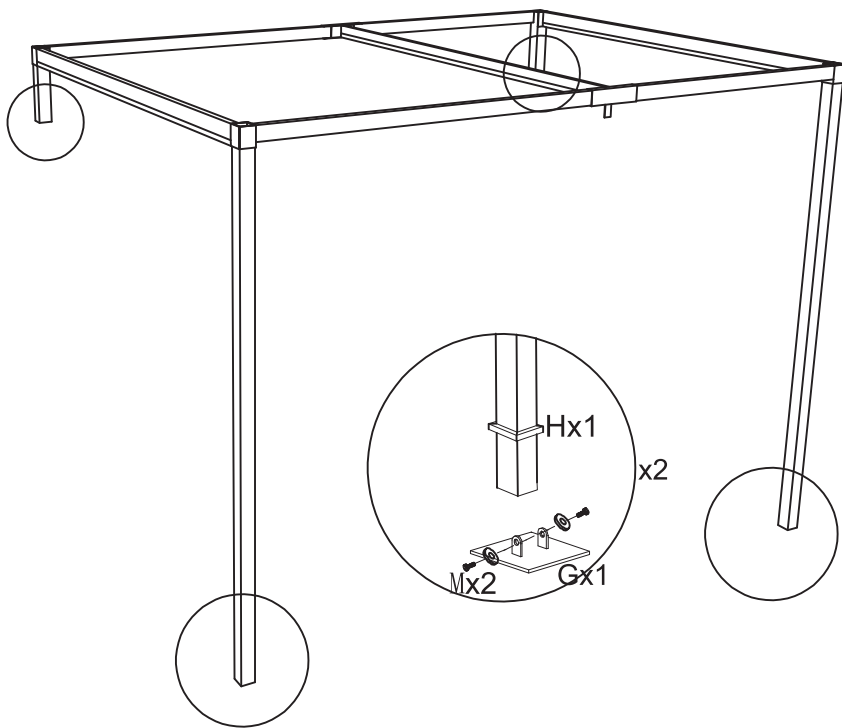

M x8

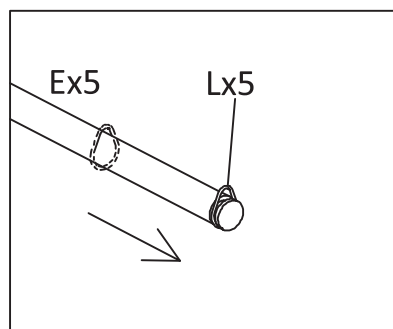
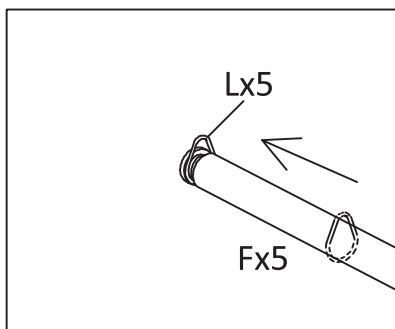
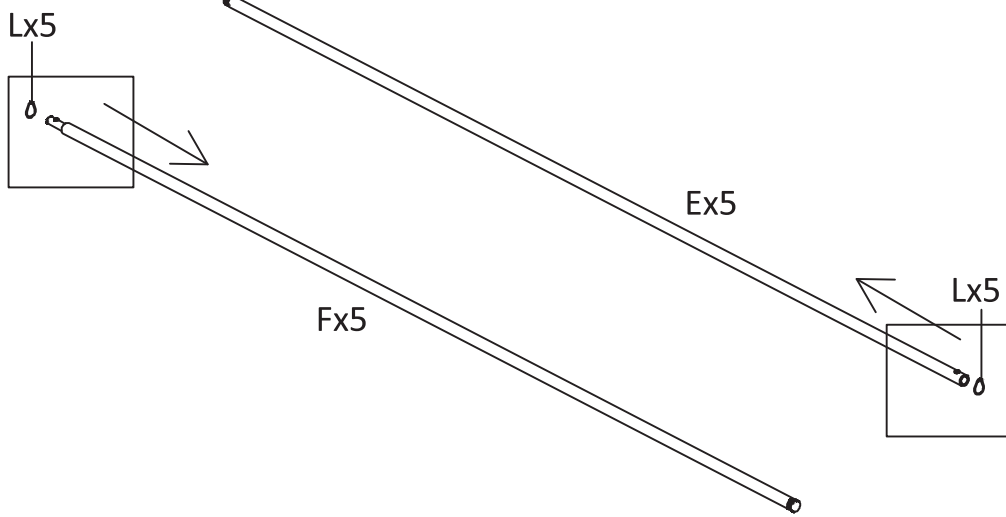

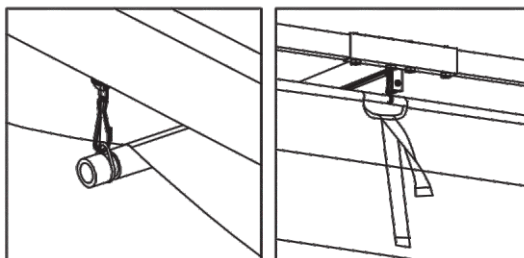
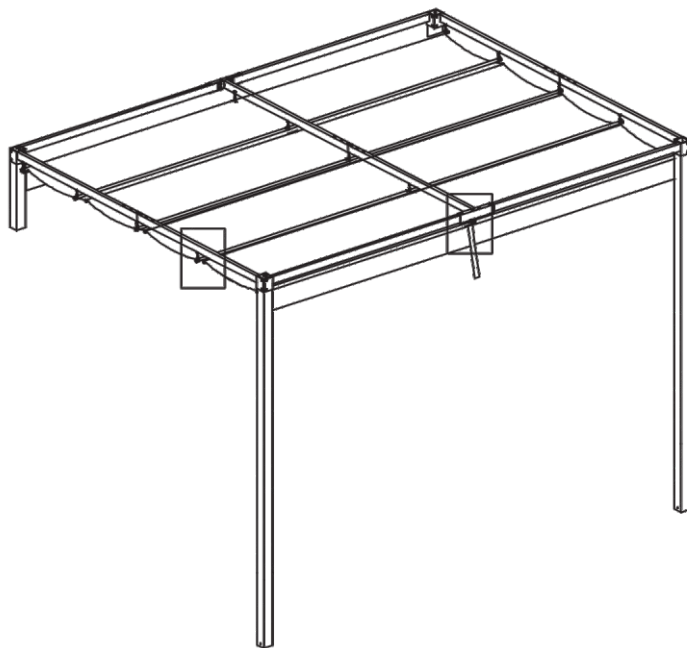
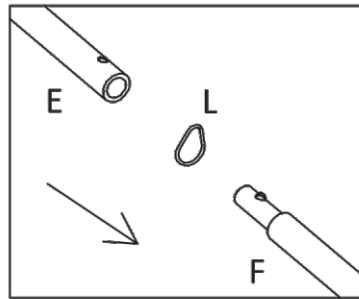
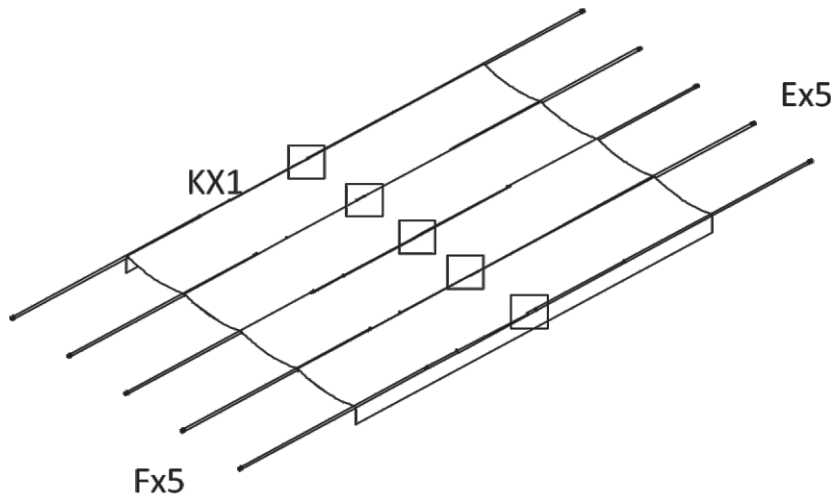

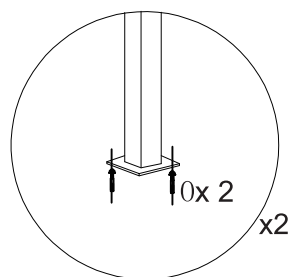
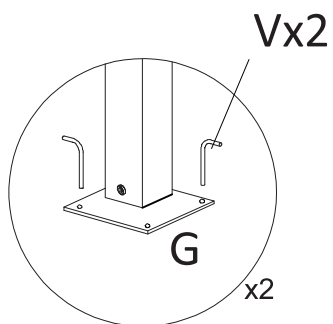
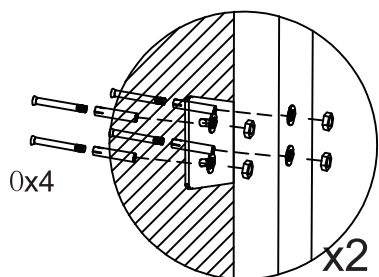
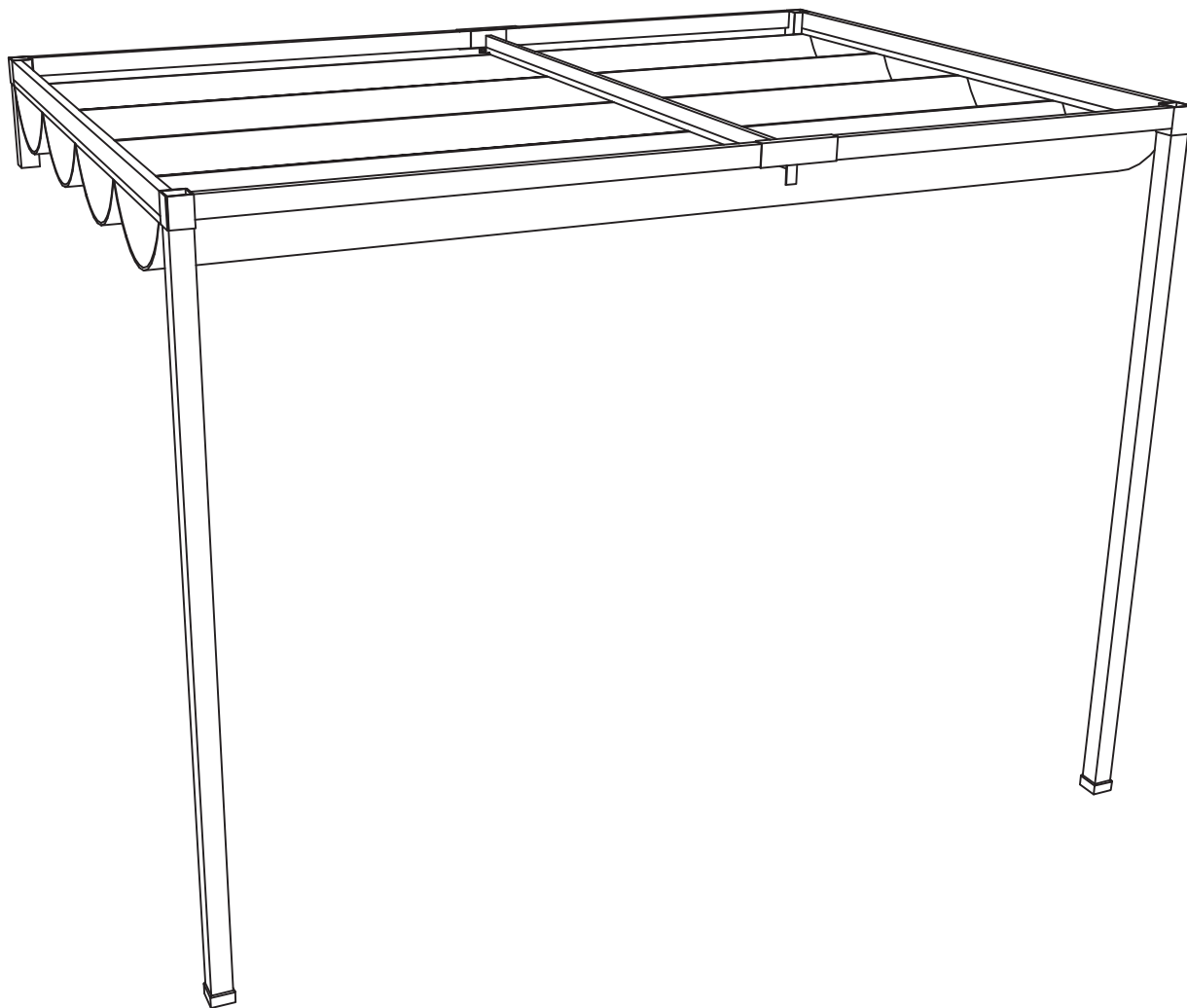

US

Imported by Aosom LLC
27150 SW Kinsman Rd Wilsonville, OR 97070 USA
MADE IN CHINA

CA

Imported by Aosom Canada Inc.
7270 Woodbine Avenue, Unit 307, Markham, Ontario Canada
L3R 4B9
MADE IN CHINA

Importé par Aosom Canada Inc.
7270 Woodbine Avenue, unité 307, Markham, Ontario Canada
L3R 4B9
Fabriqué en Chine

UK

IMPORTER ADDRESS:
MH STAR UK LTD
Unit 27, Perivale Park,
Horsenden lane South
Perivale, UB6 7RH
MADE IN CHINA

FR

ADRESSE D'IMPORTATION:
MH FRANCE
2 Rue Maurice Hartmann
92130 Issy Les Moulineaux
France
FABRIQUÉ EN CHINE



Adresses sur quefairedemesdechets.fr

ES

IMPORTADOR:
SPANISH AOSOM, S.L.
C/ROC GROS, Nº15.08550, ELS HOSTALET DE BALENYÀ, SPAIN.
B66295775
WWW.AOSOM.ES
ATENCIONCLIENTE@AOSOM.ES
TEL: 931294512
HECHO EN CHINA

PT

SPANISH AOSOM, S.L
C.ROC GROS N.15, 08550. ELS HOSTALET DE BALENYÀ
TEL: 931294512 (SEG-SEX DAS 7:30H ÀS 16:30H)
INFO@AOSOM.PT
WWW.AOSOM.PT

DE

ADRESSE DES IMPORTEURS:
MH Handel GmbH
Wendenstraße 309
D-20537 Hamburg
Germany
IN CHINA HERGESTELLT

IT

IMPORTATO DA:
AOSOM Italy srl
Centro Direzionale Milanofiori
Strada 1 Palazzo F1
20057 Assago (MI)
P.I.: 08567220960
FATTO IN CINA



Mounting on a concrete wall

The awnings must be installed at least at the thickness of 10cm only on a reinforced concrete wall. If the wall shows cracks you have to consult a professional.



The maximum load for the non-retractable parts of the awning: 600N

Tools Recommended:

Chopping bit Ø10mm 

HARDWARE:



M6*50

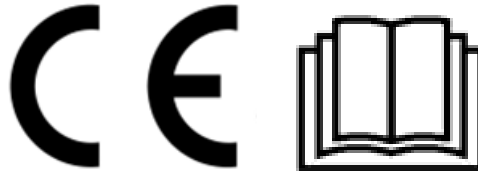

Storage

When it is unused for a long time, it is suggested to take the awning out of the mounting bracket, and properly store it.

- Before storage, ensure that the tarpaulin is completely dry, so as to prevent mildew and adhesion, and prevent permanent fatigue of waterproof adhesive tape in bending, and extend the service life of awning
- Attention! At least Three healthy adults are needed for this step.
- Remove the awning by above step of mounting instructions in reversed order.
- Retract the awning completely.
- Store the awning in a dry and safe place away from children.

Maintenance

Maintenance can extend the service life of the awning.

- Check whether the bolts are loose once a month; please tighten if loose bolts and nuts are found
- If it is damaged or not properly tightened, please immediately stop using the Pergola awning
- Clean once a month to keep the appearance clean
- After cleaning the tarpaulin, check the tightness of the fabric.
- Under normal circumstances, awning does not need lubrication. If there is abnormal noise or hard contraction, please use plastic lubricant, and do not use petroleum-based lubricant.
- Avoid leaving frozen ice on awning, or it is easy to damage the sunshade cloth and cause needless loss.
- If problems occur in the process of using, please contact the authorized center for inspection and maintenance.

Wind resistance class

The awning is rated Wind Class 1 when firmly anchored with the correct mounting material and must be retracted immediately at wind speeds of 28 km/h and above.

Wind Class 1

Speed 20-28 km/h = 5.5-7.9 m/s.

Disposal:

The same as the installation steps; three adults with professional skills are needed; the disassembly is opposite to the installation.

At the end of your item's long service life, please dispose of the valuable raw materials properly so that proper recycling can take place. If you are not sure how best to proceed, the local waste disposal companies or recycling centre will be happy to help.



IN230900084V01_GL

84C-469V00_84C-469V01

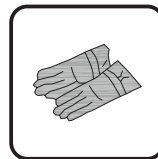
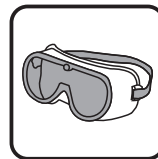
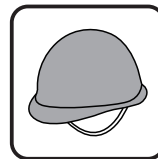
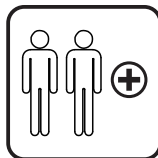
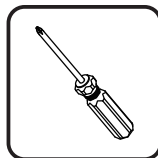
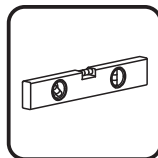
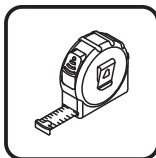
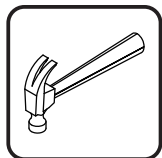
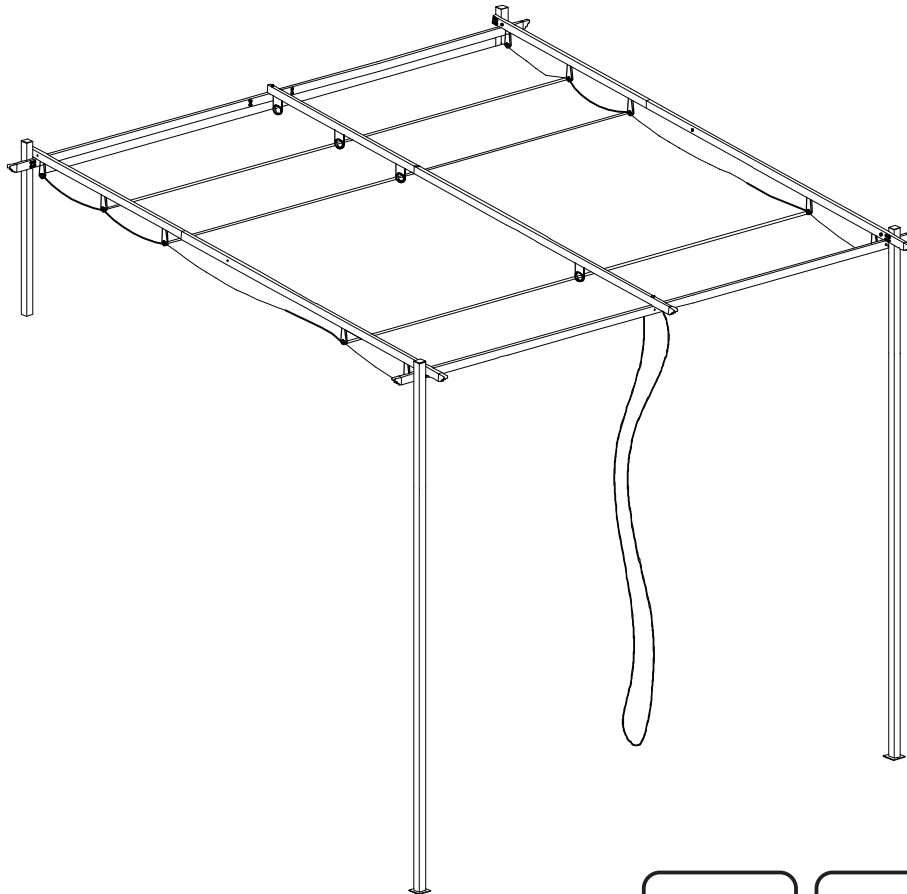

Tools Recommended

EN_IMPORTANT, RETAIN FOR FUTURE REFERENCE: READ CAREFULLY.

FR_IMPORTANT: A LIRE ATTENTIVEMENT ET À CONSERVER POUR CONSULTATION ULTÉRIEURE.

ES_IMPORTANTE, LEA Y GUARDE PARA FUTURAS REFERENCIAS.

PT_IMPORTANTE, RETER PARA REFERÊNCIA FUTURA: LEIA ATENTAMENTE.

DE_WICHTIG! SORGFÄLTIG LESEN UND FÜR SPÄTER NACHSCHLAGEN AUFBEWAHREN.

IT_IMPORTANTE! CONSERVARE IL PRESENTE MANUALE PER FUTURO RIFERIMENTO E LEGGERLO ATTENTAMENTE.

EN

Dear customer,

Thank you for purchasing this product. So that your appliance serves you well, please read all the instructions in this user's manual. If you have any questions, please contact our customer care center, Our contact details are below:

FR

Cher client,

Nous vous remercions d'avoir acheté ce produit. Afin que vous puissiez profiter pleinement de votre appareil, veuillez lire toutes les instructions de ce manuel d'utilisation. Si vous avez la moindre question, veuillez contacter notre centre d'assistance à la clientèle, Nos coordonnées sont les suivantes:

DE

Sehr geehrter Kunde,

Vielen Dank, dass Sie dieses Produkt erworben haben. Damit Ihr Gerät Ihnen gute Dienste leistet, lesen Sie bitte alle Hinweise in diesem Benutzerhandbuch. Wenn Sie Fragen haben, wenden Sie sich bitte an unser Kundendienstzentrum, Unsere Kontaktdaten stehen unten:

ES

Queridos clientes,

Gracias por comprar este producto. Para que su electrodoméstico le sirva mejor, lea todas las instrucciones de este manual del usuario. Si tiene alguna pregunta, comuníquese con nuestro Centro de Atención al Cliente, Nuestros datos de contacto son los siguientes:

PT



Caros clientes,

Obrigado por adquirir este produto. Para que o seu aparelho o sirva melhor, leia todas as instruções deste manual do utilizador. Se tiver alguma dúvida, por favor contacte o nosso Centro de Atendimento ao Cliente, Os nossos dados de contacto são os seguintes:

IT

Caro Cliente,

Grazie per aver acquistato questo prodotto. Per servirti meglio con questo apparecchio ti prego di leggere tutte le istruzioni in presente manuale utente. In caso di dubbio, si prega di contattare il nostro centro assistenza clienti, I nostri dettagli di contatto sono di seguito:

Country	 Phone	 Email
US	001-877-644-9366	customerservice@aosom.com
CA	416-792-6088	customerservice@aosom.ca
UK	0044-800-240-4004	enquiries@mhstar.co.uk
DE	0049-0(40)-88307530	service@aosom.de
FR	0033-1-84166106	aosom@mhfrance.fr
ES	0034-931294512	atencioncliente@aosom.es
PT	0034-931294512	info@aosom.pt
IT	0039-0249471447	clienti@aosom.it

EN**IMPORTANT SAFETY NOTICE**

Product is NOT INTENDED for the following:

- A safety barrier to prevent unsupervised access to pools, hot tubs, spas or ponds.
- As load bearing support for a building, structure, heavy objects or swings.
- Used in structures that trap wind, rain or snow that would create extra load on the product.

Accumulated snow must be removed from roof.

DO NOT climb or walk on roof for any reason.

Wear gloves to avoid injury from possible sharp edges of individual elements before assembly.

During installation, follow all safety warnings provided with your tools.

Some structures may require two or more people to install safely.

Check for underground utilities before digging or driving stakes into the ground!

It is important during assembly to closely follow the instructions, complete the assembly on a solid level surface and that you follow the instruction to square up, level and anchor the structure, this will reduce the gap at connections during assembly.

FR**AVIS IMPORTANT DE SÉCURITÉ**

Le produit n'est PAS DESTINÉ à ce qui suit :

- Une barrière de sécurité pour empêcher l'accès non surveillé aux piscines, aux spas, aux cuves thermales ou aux étangs.
- Comme support de charge pour un bâtiment, une structure, des objets lourds ou des balançoires.
- Utilisé dans des structures qui retiennent le vent, la pluie ou la neige qui créeraient une charge supplémentaire sur le produit.

La neige accumulée doit être enlevée du toit.

NE PAS grimper ou marcher sur le toit pour quelque raison que ce soit.

Portez des gants pour éviter les blessures causées par d'éventuels bords tranchants des composants avant de procéder à l'assemblage.

Lors de l'installation, respectez tous les avertissements de sécurité fournis avec vos outils.

Certaines structures peuvent nécessiter l'intervention de deux personnes ou plus pour les installer en toute sécurité.

Vérifiez la présence de services publics souterrains avant de creuser ou de planter des piquets dans le sol !

Il est important, pendant tout le processus de montage, de suivre attentivement les instructions, de terminer l'assemblage sur une surface solide et plane et de suivre les instructions d'équerrage, de mise à niveau et d'ancrage de la structure, ce qui permettra de réduire les écarts au niveau des liaisons pendant le montage.

ES**AVISO IMPORTANTE DE SEGURIDAD**

Manténgase alejado de las líneas eléctricas aéreas.

No coloque ni instale su tienda de campaña debajo de los árboles debido a posibles rayos o hundimiento de las ramas de los árboles en condiciones climáticas adversas. Para obtener las mejores condiciones en caso de viento fuerte, coloque el extremo estrecho de la tienda en la dirección del viento.

No dejes caer la tienda de campaña.

No haga rebotar ni golpee la bolsa de la tienda para sacarla, estas acciones podrían dañar el marco.

ESTE PRODUCTO REQUIERE UN MÍNIMO DE DOS PERSONAS PARA SU MONTAJE

Bajo ninguna circunstancia se debe utilizar este producto para cubrir automóviles, vehículos marinos o artículos similares.

PRECAUCIÓN: Vigile no pellizcarse los dedos durante el montaje y desmontaje de la tienda al unir las piezas del marco.

AVISO DE SEGURANÇA IMPORTANTE

O produto NÃO é DESTINADO ao seguinte:

- Uma barreira de segurança para impedir o acesso sem supervisão a piscinas, banheiras, spas ou lagos.
- Como suporte de carga para um edifício, estrutura, objectos pesados ou baloiços.
- Usado em estruturas que apanham vento, chuva ou neve que criariam carga extra sobre o produto.

A neve acumulada deve ser removida do telhado. NÃO subir ou caminhar no telhado por qualquer razão.

Usar luvas para evitar ferimentos causados por possíveis arestas vivas de elementos individuais antes da montagem.

Durante a instalação, siga todos os avisos de segurança fornecidos com as suas ferramentas. Algumas estruturas podem exigir a instalação segura de duas ou mais pessoas. Verifique a existência de utilidades subterrâneas antes de escavar ou de conduzir estacas no solo!

É importante durante a montagem seguir de perto as instruções, completar a montagem numa superfície sólida e nivelar e ancorar a estrutura, o que reduzirá a folga nas ligações durante a montagem.

WICHTIGER SICHERHEITSHINWEIS

Das Produkt ist NICHT für einen der folgenden Anwendungen bestimmt:

- Als Sicherheitsbarriere, die den unbeaufsichtigten Zugang zu Pools, Whirlpools, Spas oder Teichen verhindert.
- Als tragende Stütze für ein Gebäude, eine Struktur, schwere Gegenstände oder Schaukeln.
- Als Bestandteil einer Struktur verwendet werden, welche Wind, Regen oder Schnee abfangen, die eine zusätzliche Belastung für das Produkt darstellen würden.

Angesammelter Schnee muss vom Dach entfernt werden.

Aus keinem Grund darf das Dach bestiegen oder betreten werden.

Bitte tragen Sie stets geeignete Arbeitshandschuhe, um Verletzungen durch mögliche scharfe Kanten einzelner Elemente während der Montage zu vermeiden.

Befolgen Sie während des Installationsprozesses bitte sorgfältig alle Sicherheitswarnungen, die mit Ihren Werkzeugen geliefert werden.

Einige Strukturen können zwei oder mehr Personen erfordern, um sicher installiert zu werden.

Prüfen Sie vor dem Graben oder Eintreiben von Pfählen in den Boden, ob Erdkabel vorhanden sind!

Es ist wichtig, während der Montage die Anweisungen genau zu befolgen, Ihr Produkt auf einem festen und ebenen Untergrund aufzustellen und die Anweisung zum Aufrichten, Nivellieren und Verankern der Struktur zu befolgen, da dadurch der Spalt an den Verbindungen während der Montage verringert wird.

IMPORTANTI PRECAUZIONI DI SICUREZZA

Il prodotto NON è PROGETTATO per quanto segue:

- Una barriera di sicurezza per impedire l'accesso senza supervisione a piscine, vasche idromassaggio, spa o stagni.
- Supporto portante di edifici, strutture, oggetti pesanti o altalene.
- Parte di strutture che accumulano vento, pioggia o neve, in quanto creerebbero un carico extra sul prodotto.

La neve accumulata deve essere rimossa dal tetto.

NON salire o camminare sul tetto per nessun motivo.

Indossare guanti per evitare lesioni derivanti da spigoli vivi dei singoli componenti prima del montaggio.

Durante l'installazione, seguire tutte le precauzioni di sicurezza fornite con gli strumenti.

Alcune strutture possono richiedere due o più persone per essere installate in sicurezza.

Controlla le utenze sotterranee prima di scavare o piantare pali nel terreno!

È importante che durante il montaggio vengano seguite attentamente le istruzioni, inoltre completare il montaggio su una superficie piana e solida e seguire le istruzioni per allineare, livellare e ancorare la struttura, in quanto questo ridurrà lo spazio necessario durante il montaggio.

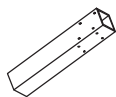

A x 1

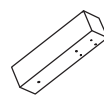

B x 1

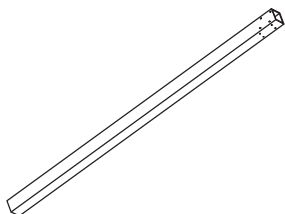

C x 1

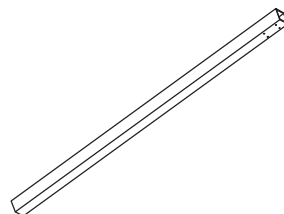

D x 1

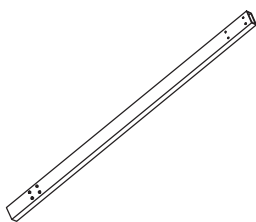

F x 1

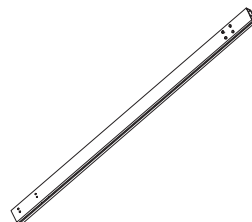

G x 1

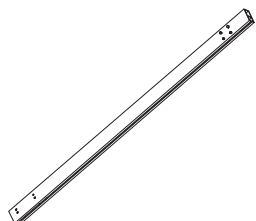

H x 1

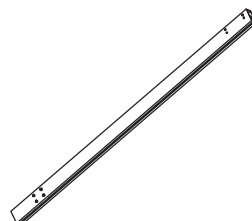

H1 x 1

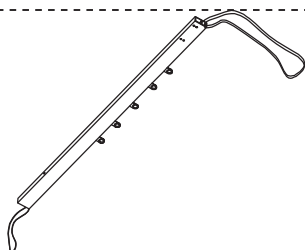

J x 1

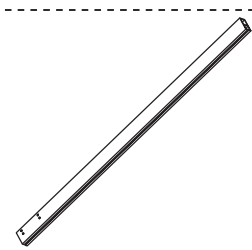

K x 1

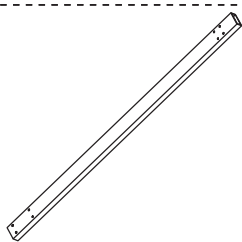

L x 1

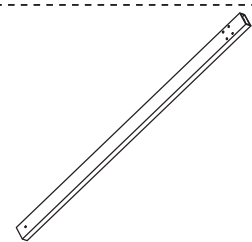

M x 2

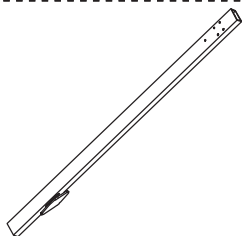

N x 1

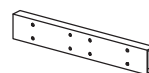

O x 2

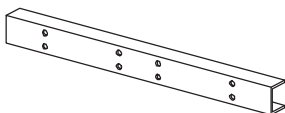

P x 3

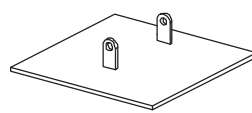

Q x 2

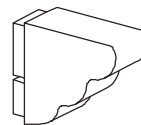
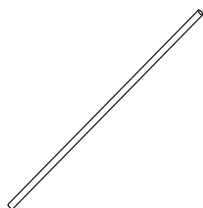
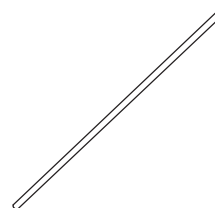
S x10**U** x 7**X** x 5**Y** x 5

HARDWARE

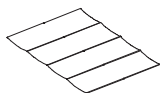
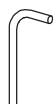
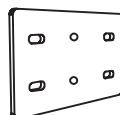
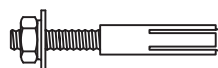
b x 2**e** x 2M6*80
+1(spare)**1** x58M6*15
+1(spare)**5** x32M6*40
+1(spare)**6** x 1**8** x 4**9** x 2**10** x12**11** x 1

EN_ Do not confuse similar screws.
FR_ Ne pas confondre des vis similaires.
ES_ No confunda tornillos similares.
PT_ Não confundir parafusos semelhantes.
DE_ Verwechseln Sie ähnliche Schrauben nicht.
IT_ Non confondere le viti simili.

NOTE

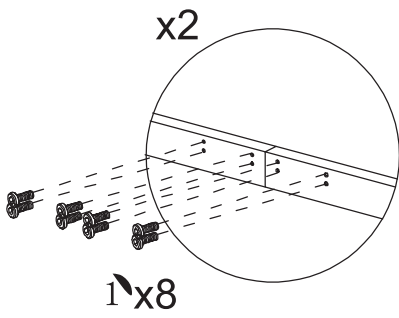
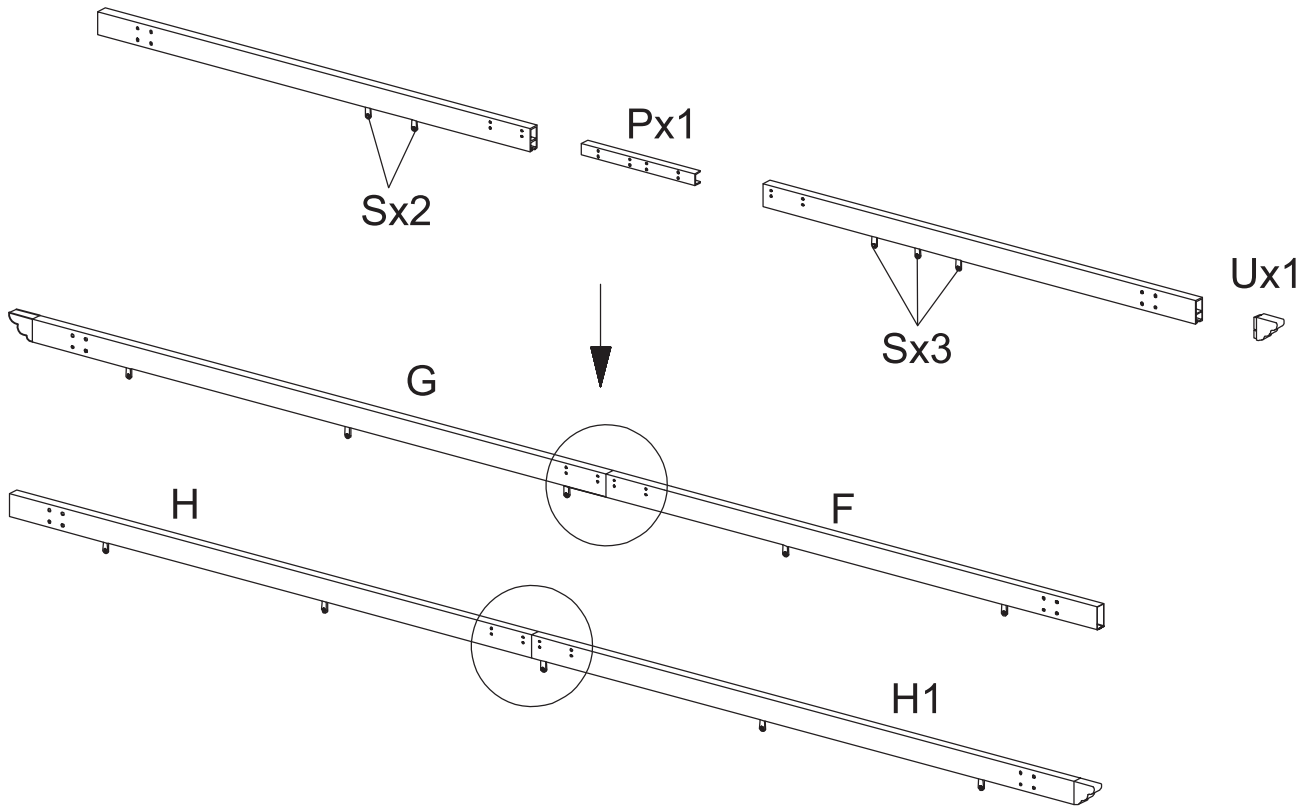
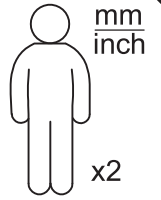

1x16

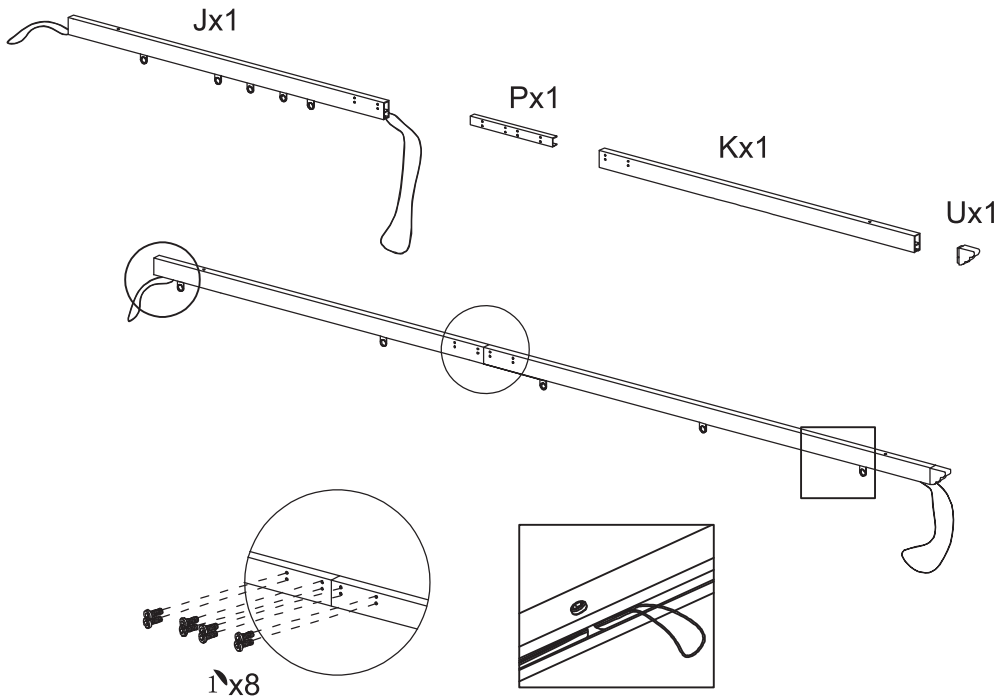

1x8

1x8

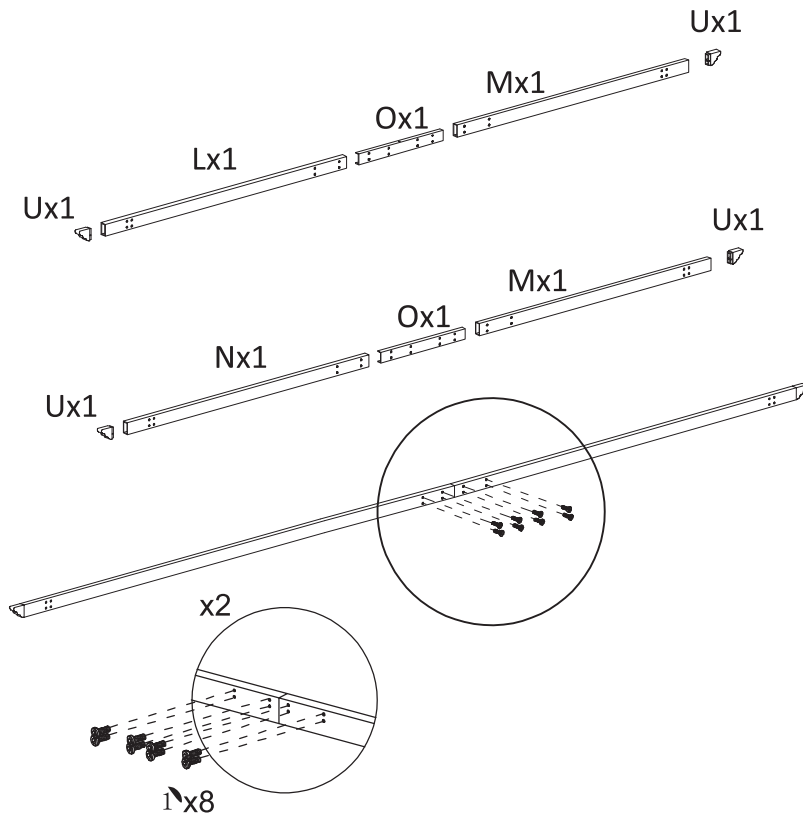

1x8

1x16

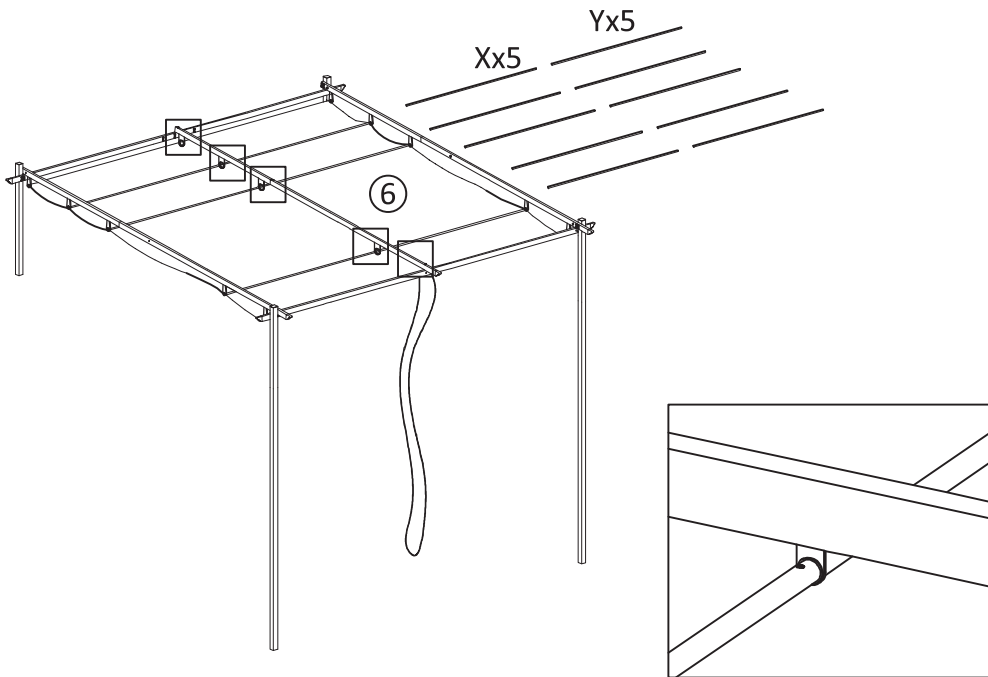
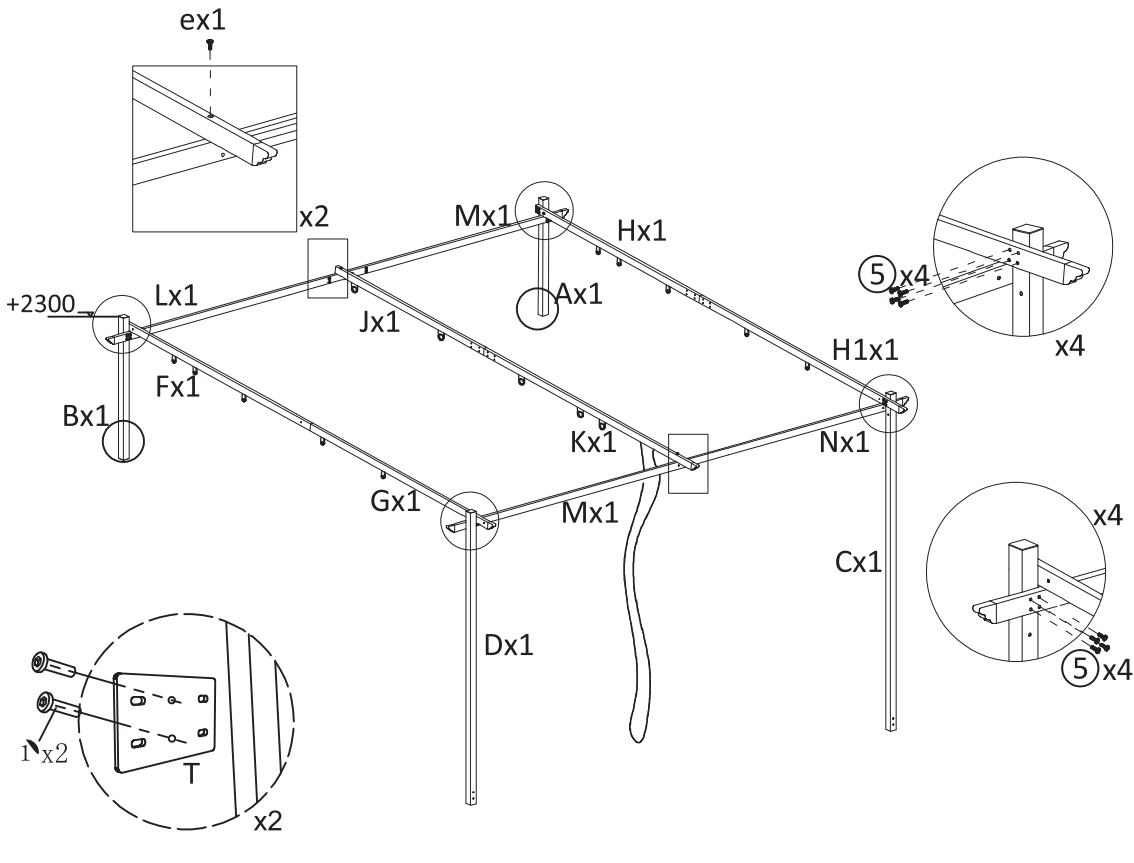

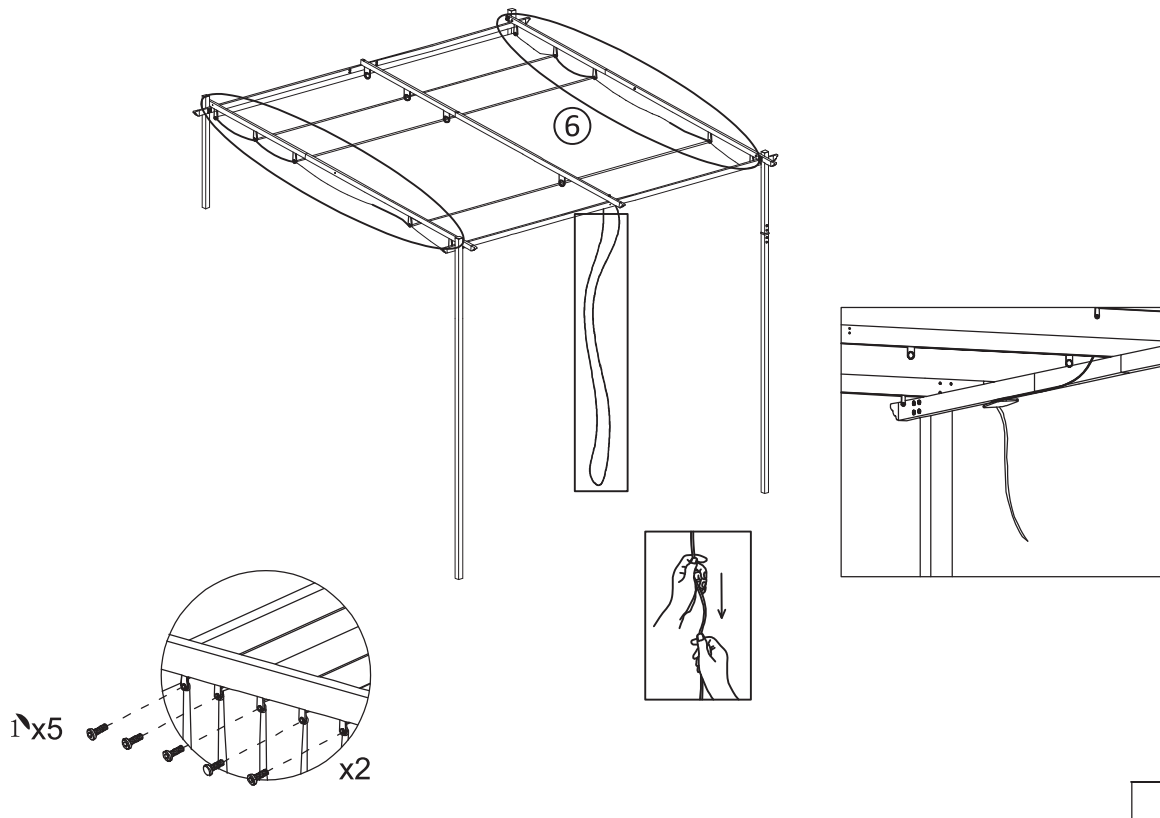

1x10

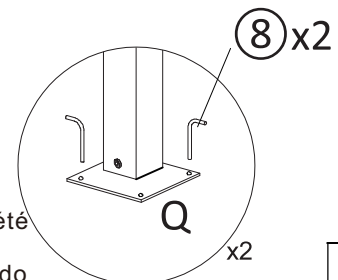
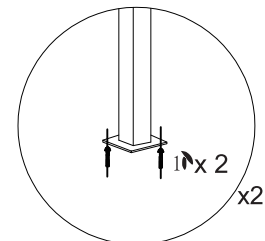
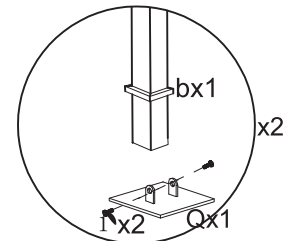
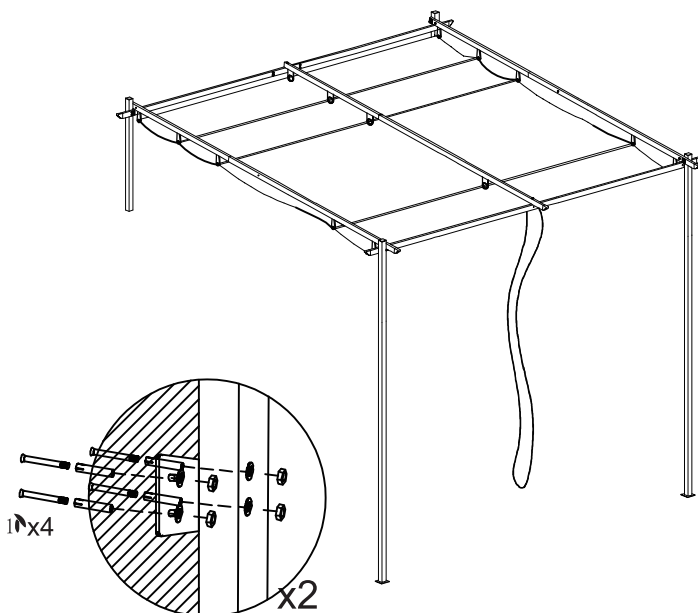

1x4

EN Before use, be sure to ensure that the product columns have been reinforced accordingly (expansion screws/ground nails) on the wall and floor.

FR Avant toute utilisation, il convient de s'assurer que les colonnes du produit ont été renforcées en conséquence (vis d'expansion/clous de sol) sur le mur et le sol.

ES Antes de utilizarlo, asegúrese de que las columnas del producto se han reforzado convenientemente (tornillos de expansión/clavos de tierra) en la pared y el suelo.

PT Antes de utilizar, certifique-se de que as colunas do produto foram devidamente reforçadas (parafusos de expansão/pregos de solo) na parede e no chão.

DE Vergewissern Sie sich vor der Verwendung, dass die Produktstützen an Wand und Boden entsprechend verstärkt sind (Dehnschrauben/Bodennägel).

IT Prima dell'uso, assicurarsi che le colonne del prodotto siano state opportunamente rinforzate (viti a espansione/chiodi a terra) sulla parete e sul pavimento.



Mounting on a concrete wall

The awnings must be installed at least at the thickness of 10cm only on a reinforced concrete wall. If the wall shows cracks you have to consult a professional.



The maximum load for the non-retractable parts of the awning : 680N

Tools Recommended: Chopping bit Ø10mm 

HARDWARE: 
M6*50



Storage

When it is unused for a long time, it is suggested to take the awning out of the mounting bracket, and properly store it.

Before storage, ensure that the tarpaulin is completely dry, so as to prevent mildew and adhesion, and prevent permanent fatigue of waterproof adhesive tape in bending, and extend the service life of awning

Attention! At least Three healthy adults are needed for this step.

Remove the awning by above step of mounting instructions in reversed order.

Retract the awning completely.

Store the awning in a dry and safe place away from children.

Maintenance

Maintenance can extend the service life of the awning.

Check whether the bolts are loose once a month; please tighten if loose bolts and nuts are found

If it is damaged or not properly tightened, please immediately stop using the Pergola awning

Clean once a month to keep the appearance clean

After cleaning the tarpaulin, check the tightness of the fabric.

Under normal circumstances, awning does not need lubrication. If there is abnormal noise or hard contraction, please use plastic lubricant, and do not use petroleum-based lubricant.

Avoid leaving frozen ice on awning, or it is easy to damage the sunshade cloth and cause needless loss.

If problems occur in the process of using, please contact the authorized center for inspection and maintenance.

Wind resistance class

The awning is rated Wind Class 1 when firmly anchored with the correct mounting material and must be retracted immediately at wind speeds of 28 km/h and above.

Wind Class 1

Speed 20-28 km/h = 5.5-7.9 m/s.

Disposal:

The same as the installation steps; three adults with professional skills are needed; the disassembly is opposite to the installation.

At the end of your item's long service life, please dispose of the valuable raw materials properly so that proper recycling can take place. If you are not sure how best to proceed, the local waste disposal companies or recycling centre will be happy to help.



Installation sur un mur en béton

Les auvents doivent être installés sur un mur en béton armé d'une épaisseur d'au moins 10 cm. Si le mur présente des fissures, il est préférable de consulter un professionnel.



La charge maximale supportée par les parties fixes de l'auvent : 680 N

Outils recommandés : Burin de 10 mm de diamètre 

MATÉRIEL :

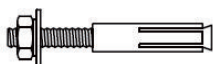
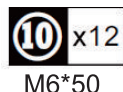

Rangement

Lorsqu'il n'est pas utilisé pendant une longue période, il est recommandé de retirer l'auvent du support de montage et de le ranger correctement.

Avant le rangement, assurez-vous que la bâche est complètement sèche pour éviter la moisissure et l'adhérence, ainsi que les dommages permanents de l'adhésif étanche lors des pliages, ceci afin de prolonger la durée de vie de l'auvent.

Attention ! Au moins trois adultes en bonne santé sont nécessaires pour cette étape.

Retirez l'auvent en suivant les instructions de montage dans l'ordre inverse.

Rétractez complètement l'auvent.

Rangez l'auvent dans un endroit sec et sûr, hors de la portée des enfants.

Entretien

L'entretien régulier peut prolonger la durée de vie de l'auvent.

Vérifiez chaque mois si les boulons sont desserrés et serrez-les si nécessaire.

En cas de dommage ou de fixation incorrecte, veuillez cesser immédiatement d'utiliser l'auvent.

Nettoyez une fois par mois pour garder un aspect propre.

Après le nettoyage de la bâche, vérifiez la tension du tissu.

En conditions normales, l'auvent n'a pas besoin de lubrification. En cas de bruit anormal ou de résistance lors de la rétraction, utilisez un lubrifiant plastique et n'utilisez pas de lubrifiant à base de pétrole.

Évitez de laisser de la glace gelée sur l'auvent, car cela peut endommager le tissu de protection solaire et causer des dommages inutiles.

En cas de problème pendant l'utilisation, veuillez contacter le centre agréé pour une inspection et une maintenance.

Résistance au vent

L'auvent est classé en résistance au vent classe 1 lorsqu'il est solidement ancré avec le matériel de montage approprié et doit être immédiatement rétracté en cas de vent d'une vitesse de 28 km/h ou plus.

Classement résistance au vent 1

Vitesse de 20 à 28 km/h = 5,5 à 7,9 m/s.

Élimination :

La procédure est la même que pour les étapes d'installation ; trois adultes professionnels compétents sont nécessaires. Le démontage se fait à l'inverse de l'installation.

En fin de vie de votre article, veuillez vous assurer de bien éliminer les matières premières précieuses afin de permettre un recyclage approprié. Si vous ne savez pas comment procéder, les entreprises de collecte des déchets de votre région ou les centres de recyclage seront heureux de vous aider.



Montaje en una pared de hormigón

Los toldos deben instalarse con un espesor mínimo de 10 cm únicamente sobre una pared de hormigón armado. Si la pared presenta grietas hay que consultar a un profesional.



La carga máxima para las partes no retráctiles del toldo: 680N/ 69,34 kg

Herramientas recomendadas: Broca de Ø10mm 

HARDWARE:  x12
M6*50

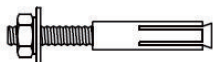

Almacenamiento

Cuando no se utilice durante un período prolongado, se sugiere sacar el toldo del soporte de montaje y guardarlo adecuadamente.

Antes del almacenamiento, asegúrese de que la lona esté completamente seca, para evitar el moho y la adherencia, y evitar la fatiga permanente de la cinta adhesiva impermeable al doblarse, y extender la vida útil del toldo.

¡Atención! Se necesitan al menos tres adultos para este paso.

Retire el toldo siguiendo el paso anterior de las instrucciones de montaje en orden inverso.

Recoger el toldo por completo.

Guarde el toldo en un lugar seco y seguro, lejos del alcance de los niños.

Mantenimiento

Un buen mantenimiento puede prolongar la vida útil del toldo.

Comprobar si los tornillos están flojos una vez al mes; apriete si se encuentran pernos y tuercas flojos.

Si está dañado o no está bien apretado, deje de usar inmediatamente el toldo.

Limpiar una vez al mes para mantener la apariencia limpia.

Después de limpiar la lona, compruebe la estanqueidad de la tela.

En circunstancias normales, el toldo no necesita lubricación. Si hay un ruido anormal o una contracción fuerte, utilice lubricante plástico y no utilice lubricante a base de petróleo.

Evite dejar hielo congelado sobre el toldo, ya que es fácil dañar la tela del parasol y provocar pérdidas innecesarias.

Si ocurren problemas en el proceso de uso, comuníquese con el centro autorizado para inspección y mantenimiento.

Resistencia al viento

El toldo tiene clasificación de viento Clase 1 cuando está firmemente anclado con el material de montaje correcto y debe retraerse inmediatamente con velocidades de viento de 28 km/h o superiores.

Clase de Viento 1

Velocidad 20-28 km/h = 5.5-7.9 m/s.

Desecho:

El mismo procedimiento que los pasos de instalación; se necesitan tres adultos con habilidades profesionales; el desmontaje es contrario a la instalación. Al final de la larga vida útil de tu artículo, por favor, desecha los materiales valiosos adecuadamente para que se pueda realizar un reciclaje adecuado. Si no estás seguro de cómo proceder, las empresas locales de eliminación de residuos o los centros de reciclaje estarán encantados de ayudarte.



Montagem numa parede de cimento

Os toldos devem ser instalados com uma espessura mínima de 10 cm apenas numa parede de cimento resistente. Se a parede apresentar fissuras, é necessário consultar um profissional.



A carga máxima para as partes não retrácteis do toldo: 680N (69,34 kg)

Ferramentas recomendadas: Broca de corte Ø10mm 

HARDWARE: 
M6*50

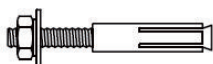

Armazenamento

Se não for utilizado durante muito tempo, é aconselhável retirar o toldo do suporte de montagem e guardá-lo corretamente.

- Antes de o guardar, certifique-se de que o toldo está completamente seco, de modo a evitar o bolor e a aderência, e evitar a danificação permanente da película adesiva à prova de água ao dobrar, e prolongar a vida útil do toldo
- Atenção! São necessários pelo menos três adultos bem dispostos para efetuar esta operação.
- Retirar o toldo seguindo a ordem inversa das instruções de montagem acima indicadas.
- Recolher completamente o toldo.
- Guardar o toldo num local seco e seguro, longe do alcance das crianças.

Manutenção

A manutenção pode prolongar a vida útil do toldo.

- Verificar se os parafusos estão soltos uma vez por mês; se encontrar parafusos e porcas soltos, aperte-os.
- Se estiverem danificados ou mal apertados, interromper imediatamente a utilização do toldo.
- Limpar uma vez por mês para manter o aspeto limpo.
- Depois de limpar o toldo, verificar o aperto do tecido.
- Em circunstâncias normais, o toldo não necessita de lubrificação. Se houver um ruído anormal ou uma contração forte, utilize um lubrificante de plástico e não utilize um lubrificante à base de petróleo.
- Evite deixar gelo congelado no toldo, caso contrário é fácil danificar o tecido e causar perdas desnecessárias.
- Se ocorrerem problemas no processo de utilização, contactar o serviço de atenção ao cliente.

Classe de resistência ao vento

O toldo é classificado como sendo de classe de resistência ao vento 1 quando firmemente ancorado com o material de montagem correto e deve ser imediatamente recolhido a velocidades de vento de 28 km/h e superiores.

Classe de vento 1

Velocidade 20-28 km/h = 5,5-7,9 m/s.

Descarte:

O mesmo que os passos de instalação; são necessários três adultos com competências profissionais; a desmontagem é oposta à instalação.

No final da longa vida útil do seu artigo, elimine corretamente as matérias-primas valiosas para que possa ser feita uma reciclagem adequada. Se não tiver a certeza de como proceder, as empresas locais de eliminação de resíduos ou o centro de reciclagem terão todo o prazer em ajudar.



Montage an einer Betonwand

Die Markise muss an einer mindestens 10 cm dicken Stahlbetonwand montiert werden. Wenn die Wand Risse aufweist, muss ein Fachmann zu Rate gezogen werden.



Die maximale Belastung für die nicht einziehbaren Teile der Markise beträgt: 680 N

Empfohlenes Werkzeug: Spiralbohrer Ø 10 mm. 

HARDWARE:  x12
M6*50



Lagerung

Bei längerem Nichtgebrauch ist die Markise aus der Halterung zu nehmen und ordnungsgemäß zu lagern.

Vor der Lagerung sollte die Plane vollständig getrocknet sein, um Schimmelbildung und Verklebungen zu vermeiden, eine dauerhafte Ermüdung des wasserdichten Klebebandes beim Biegen zu verhindern und die Lebensdauer der Markise zu verlängern.

Achtung! Für diesen Arbeitsschritt sind mindestens drei kräftige Erwachsene erforderlich.

Demontage der Markise in umgekehrter Reihenfolge wie in der Montageanleitung beschrieben.

Markise vollständig einfahren.

Die Markise an einem trockenen und sicheren Ort außerhalb der Reichweite von Kindern lagern.

Wartung

Wartung kann die Lebensdauer der Markise verlängern.

Kontrollieren Sie einmal im Monat, ob die Schrauben und Muttern fest angezogen sind

Wenn sie beschädigt oder nicht richtig angezogen sind, darf die Markise nicht mehr benutzt werden

Reinigen Sie die Markise einmal im Monat, damit sie sauber aussieht.

Prüfen Sie nach dem Reinigen der Markise, ob das Tuch dicht ist.

Unter normalen Umständen muss die Markise nicht geschmiert werden. Sollten Sie ungewöhnliche Geräusche oder ein schwergängiges Einfahren feststellen, verwenden Sie bitte Kunststoffschmiermittel und kein Schmiermittel auf Erdölbasis.

Vermeiden Sie gefrorenes Eis auf der Markise, da es leicht das Markisentuch beschädigen und zu unnötigen Schäden führen kann.

Sollten während des Gebrauchs Probleme auftreten, wenden Sie sich bitte an eine autorisierte Inspektions- und Servicestelle.

Windwiderstandsklasse

Die Markise ist in Windklasse 1 eingestuft, wenn sie mit dem richtigen Befestigungsmaterial fest verankert ist. Ab einer Windgeschwindigkeit von 28 km/h und mehr muss sie sofort eingefahren werden.

Windklasse 1

Windgeschwindigkeit von 20 bis 28 km/h = 5,5 bis 7,9 m/s.

Entsorgung:

Gleiche Schritte wie bei der Montage; drei erwachsene, fachkundige Personen erforderlich; die Demontage erfolgt in umgekehrter Reihenfolge zur Montage.

Bitte entsorgen Sie am Ende der langen Nutzungsdauer die wertvollen Rohstoffe ordnungsgemäß, damit ein fachgerechtes Recycling stattfinden kann. Wenn Sie sich nicht sicher sind, wie Sie am besten vorgehen sollen, helfen Ihnen die örtlichen Entsorgungsbetriebe oder Recyclinghöfe gerne weiter.



Montaggio su muro di cemento

Le tende da sole devono essere installate ad una profondità di almeno 10 cm e solo su una parete in cemento armato. Se la parete presenta crepe, è necessario consultare un professionista.



Carico massimo per le parti non retrattili della tenda da sole: 680 N

Attrezzi consigliati: Punta per muratura da Ø10mm 

HARDWARE: 
M6*50

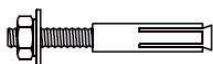

Stoccaggio

Quando non viene utilizzata a lungo, si consiglia di rimuovere la tenda da sole dalla staffa di montaggio e di stoccarla in modo corretto.

Prima di riporla, assicurarsi che il telone sia completamente asciutto, in modo da prevenire la formazione di muffe e aderenza, per evitare l'usura permanente del nastro adesivo impermeabile durante il ripiegamento e prolungare la durata dell'intera tenda da sole.

Attenzione! Per questo passaggio è necessario l'intervento di almeno tre adulti in buona forma.

Rimuovere la tenda seguendo i passaggi delle istruzioni di montaggio precedenti in ordine inverso.

Ritrarre completamente la tenda.

Stoccare la tenda in un luogo asciutto e sicuro, lontano dalla portata dei bambini.

Manutenzione

La manutenzione può prolungare la durata della tenda da sole.

Controllare una volta al mese se i bulloni sono allentati; si prega di stringerli se si rilevano bulloni e dadi allentati.

Qualora fosse danneggiata o non fosse bloccata correttamente, interrompere immediatamente l'utilizzo della tenda.

Pulire una volta al mese per mantenere l'aspetto esteriore pulito.

Dopo aver pulito il telone, verificare la tenuta del tessuto.

In circostanze normali, la tenda non necessita di lubrificazione. In caso di rumore anomalo o forte contrazione, utilizzare lubrificante per plastica e non lubrificante a base di petrolio.

Evitare di lasciare che si formi ghiaccio sul telone, altrimenti il tessuto della tenda verrà facilmente danneggiato causando perdite inutili.

Se si verificano problemi durante l'utilizzo, contattare il centro autorizzato per procedere all'ispezione e alla manutenzione.

Classe di resistenza al vento

La tenda da sole è classificata come Classe Vento 1 quando è ancorata saldamente e deve essere ritratta immediatamente in caso la velocità del vento sia pari o superiore a 28 km/h.

Vento di classe 1

Velocità 20-28 km/h = 5,5-7,9 m/s.

Smaltimento:

Come per i passaggi di installazione, sono necessari tre adulti con competenze professionali; lo smontaggio segue il procedimento opposto all'installazione.

Al termine del lungo ciclo di vita utile di questo articolo, smaltire correttamente le materie prime di valore in modo che avvenga un corretto riciclaggio. Se non siete sicuri di come procedere, le aziende locali che occupano di smaltimento dei rifiuti o il centro di riciclaggio saranno felici di aiutarvi.

If you have any questions, please contact our customer care center, Our contact details are below:

US

 001-877-644-9366

 customerservice@aosom.com

Imported by Aosom LLC
27150 SW Kinsman Rd Wilsonville, OR 97070 USA
MADE IN CHINA

If you have any questions, please contact our customer care center, Our contact details are below:

CA

 416-792-6088

 customerservice@aosom.ca

Imported by Aosom Canada Inc.
7270 Woodbine Avenue, Unit 307, Markham,
Ontario Canada L3R 4B9
MADE IN CHINA

Si vous avez la moindre question, veuillez contacter notre centre d'assistance à la clientèle, Nos coordonnées sont les suivantes:

 416-792-6088

 customerservice@aosom.ca

Importé par Aosom Canada Inc.
7270 Woodbine Avenue, unité 307,
Markham, Ontario Canada L3R 4B9
FABRIQUÉ EN CHINE

If you have any questions, please contact our customer care center, Our contact details are below:

UK

 0044-800-240-4004

 enquiries@mhstar.co.uk

IMPORTER ADDRESS:
MH STAR UK LTD
Unit 27, Perivale Park,
Horsenden lane South
Perivale, UB6 7RH
MADE IN CHINA

Si vous avez la moindre question, veuillez contacter notre centre d'assistance à la clientèle, Nos coordonnées sont les suivantes:

FR

 0033-1-84166106

 aosom@mhfrance.fr

Importé par/Fabricant/REP:
MH FRANCE
2 Rue Maurice Hartmann
92130 Issy Les Moulineaux
France
FABRIQUÉ EN CHINE

Wenn Sie Fragen haben, wenden Sie sich bitte an unser Kundendienstzentrum, Unsere Kontaktdaten stehen unten:

DE

 0049-0(40)-88307530

 service@aosom.de

ADRESSE DES IMPORTEURE/Hersteller/REP:
MH Handel GmbH
Wendenstraße 309
D-20537 Hamburg
Germany
IN CHINA HERGESTELLT

In caso di dubbio, si prega di contattare il nostro centro assistenza clienti, I nostri dettagli di contatto sono di seguito:

IT

 0039-0249471447

 clienti@aosom.it

IMPORTATO DA/Produttore/REP:
AOSOM Italy srl
Centro Direzionale Milanofiori
Strada 1 Palazzo F1
20057 Assago (MI)
P.I.: 08567220960
FATTO IN CINA

Si tiene alguna pregunta, comuníquese con nuestro Centro de Atención al Cliente, Nuestros datos de contacto son los siguientes:

ES

 0034-931294512

 atencioncliente@aosom.es

IMPORTADOR/Fabricante/REP:
SPANISH AOSOM, S.L.
C/ROC GROS, N°15.08550, ELS HOSTALETES DE
BALENYÀ, SPAIN.
B66295775
HECHO EN CHINA

Se tiver alguma dúvida, por favor contacte o nosso Centro de Atendimento ao Cliente, Os nossos dados de contacto são os seguintes:

PT

 0034-931294512

 info@aosom.pt.

IMPORTADOR/Fabricante/REP:
SPANISH AOSOM, S.L.
C.ROC GROS N.15, 08550. ELS HOSTALETES DE
BALENYÀ
FEITO NA CHINA



FR

**DONNEZ
OU
RECYCLEZ**



OU



OU



ASSOCIATION

LIVRAISON

DÉCHÈTERIE

Adresses sur quefairedemesdechets.fr