

ASSEMBLY INSTRUCTIONS

Thank you for purchasing this quality product . Be sure to check all packaging material carefully for small parts that may have come loose inside the carton during shipment .

"Hardware is attached underneath the seat bottom"

Components List :

NO	DESCRIPTION	SKETCH	QTY
A	Back Frame		1pc
B	Cushion Seat		1pc
C	Seat Frame		1pc
D	Front Leg (Left)		1pc
E	Front Leg (Right)		1pc
F	Side Stretcher (Left)		1pc
G	Side Stretcher (Right)		1pc

Hardware List :

NO	DESCRIPTION	SIZE	SKETCH	QTY
1	Wrench	12x75 mm		1pc
2	Allen Key	58x23x4 mm		1pc
3	Short Bolt	1/4" x38 mm		3pcs
4	Long Bolt	1/4" x85 mm		4pcs
5	Hex-Nut	5/16"		4pcs
6	Spring Washer	5/16" x Ø12		11pcs
7	Flat Washer	5/16" x Ø19		11pcs
8	Wood Screw	Ø8 x 50 mm		4pcs

Reminders

1. Use only the hardware supplied.
2. Once the chair is finished, level and tighten all the bolts.
3. Do not over-tighten bolts.
4. This item may require periodic tightening.

NOTE :

1. Hardware pack is located underneath the Cushion Seat (B).
2. Two or more people are needed for assembly. Please keep all hardware parts out of the reach of children.

Step1: Attach the Seat Frame (C) with Cushion Seat (B) to Back Frame (A) by using Flat Washer (7), Spring Washer (6) and Bolt (3&4).

Step2: Attach Side Stretcher (F&G) to Back Frame (A) using Wood Screws (8) through pre-drilled holes of Side Stretcher (F&G) and Back Frame (A). Attach the assembled Front Leg (D&E) to Seat Frame (C) by using Flat Washers (7), Spring Washers (6) and Hex-Nut (5). Attach Front Legs (D&E) to the Side Stretcher (F&G) using Wood Screws (8) through pre-drilled holes on the Side Stretcher (F&G).

Assembly is now complete

Thank you for choosing this product.

STEP 1

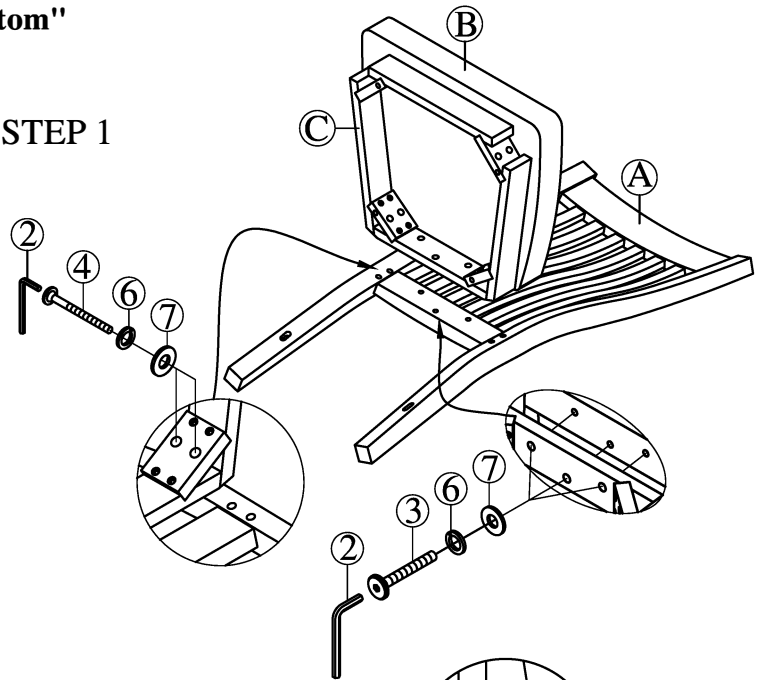

STEP 2

