



















ASSEMBLY INSTRUCTIONS PART LIST

1	TOP SHELF		1PC	5	BASE SHELF		1PC
2	BOTTOM FRAME		2PCS	6	MIDDLE SHELVES		4PCS
3	UPPER FRAME		2PCS	7	REAR FRAME		4PCS
4	MIDDLE FRAME		2PCS				

HARDWARE LIST

A	LONG BOLT M6*30		24PCS	B	LONG BOLT M8*15		16PCS
C	HEX NUT M6		8PCS	D	ALLEN KEY M4		1PC
E	LONG BOLT M6*40		6PCS	F	ALLEN KEY M5		1PC
G	SELF-TAPPING SCREW 4*45MM		4PCS	H	DRYWALL ANCHOR 8*40MM		4PCS
I	ANTI-TIP BRACKET		2PCS	J	OPEN-END WRENCH 10MM		1PC
K	LONG BOLT M6*20		2PCS				

STEP 1

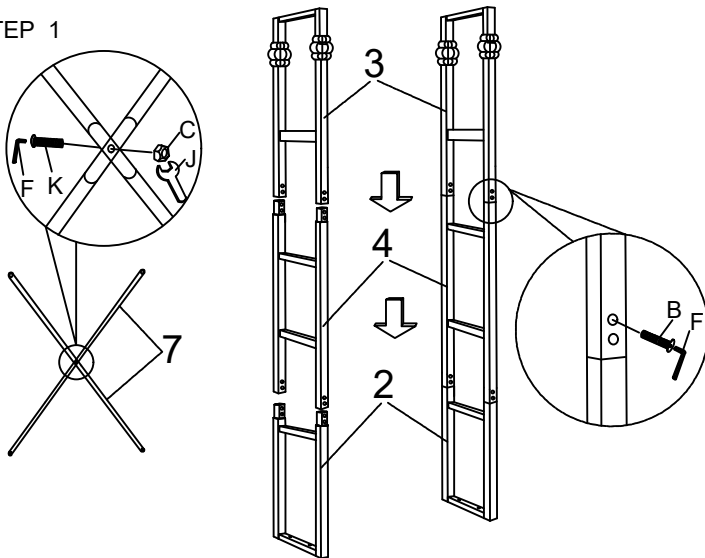

STEP 2

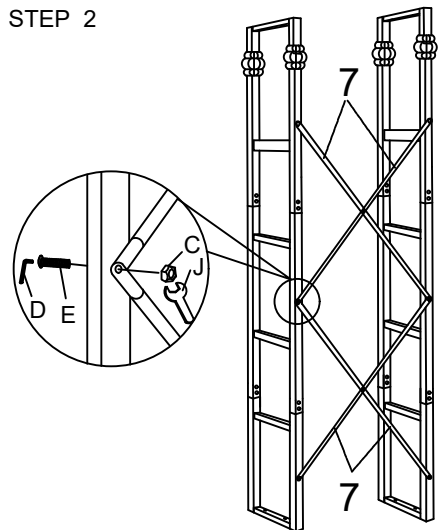

STEP 3

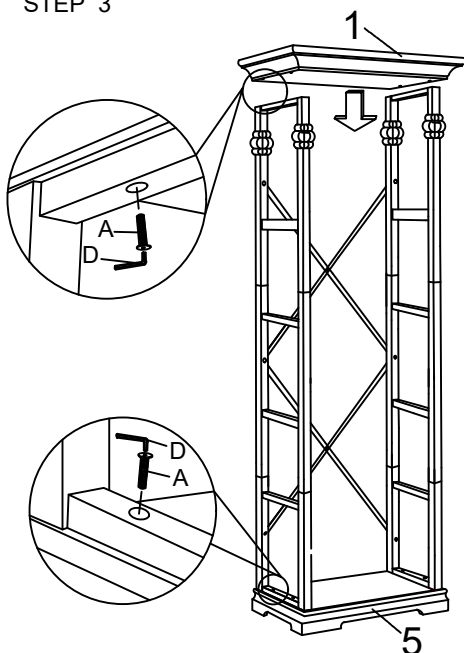

STEP 4

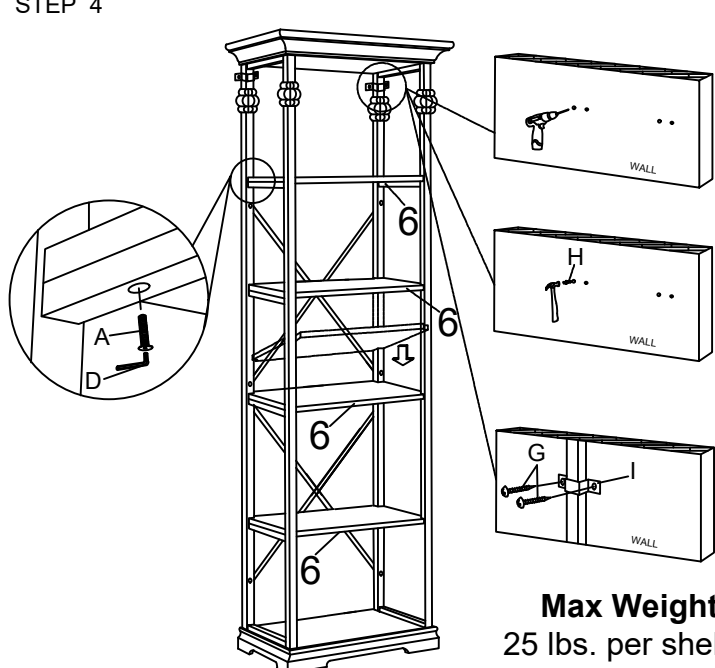

Max Weight:
25 lbs. per shelf