

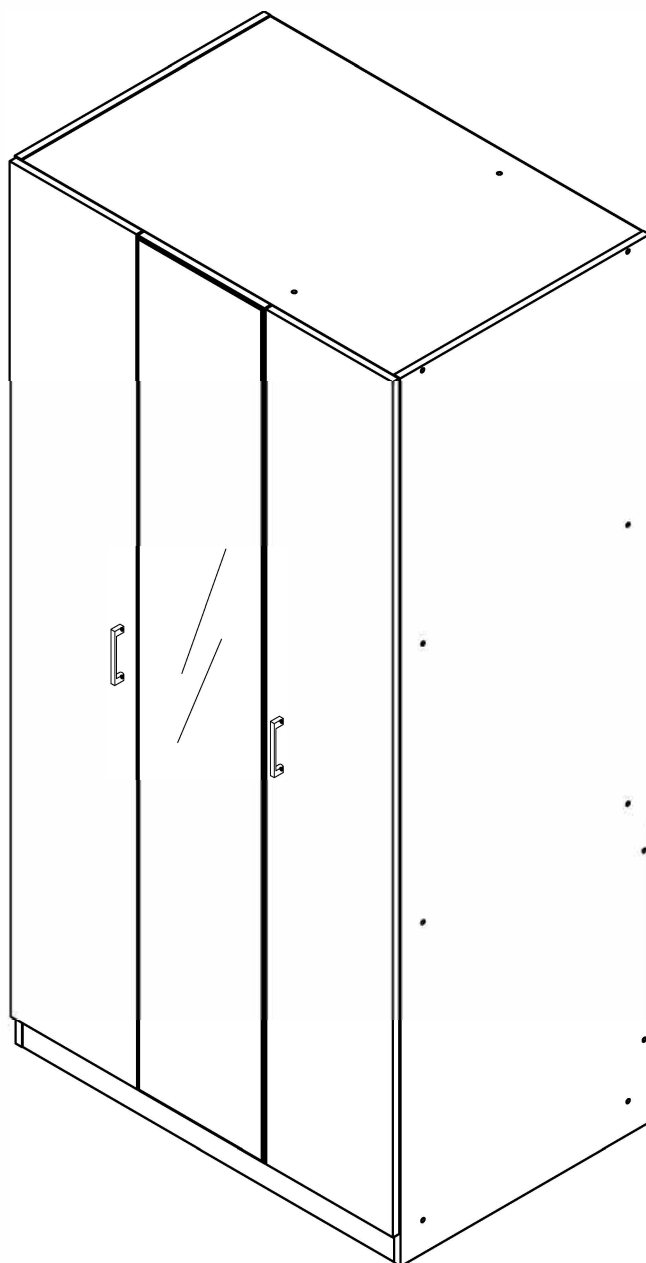



ASSEMBLY INSTRUCTIONS / INSTRUCTIONS
D' ASSEMBLAGE / INSTRUCTIVO DE ARMADO





3 DOOR WARDROBE

NOTES ON ASSEMBLY

- To ensure ease of assembly read all instructions before assembly and follow step by step illustrations.
- Keep instructions for future use.
- Adult assembly required.  2 person required. 
- Due to the presence of small parts during assembly, keep out of reach of children until assembly is complete.

- Pour assurer l' assemblage facile veuillez lire toutes les instructions avant l' assemblage et veuillez suivre les illustrations pour chaque etapes.
- Veuillez garder ces instructions pour l'usage ulterieur.
- Assemblage requis pas un adulte.  2 personnes requises. 
- Due a la presence de petite pieces durant l'assemblage, veuillez garder hors de porter des enfants jusqu'a ce que l'assemblage soit completer.

- Para garantizar la facilidad de ensamble lea las instrucciones antes de iniciar y siga paso a paso las ilustraciones.
- Guarde las instrucciones para futuras referencias.
- El ensamble requiere de un adulto.  2 personas requeridas. 
- Debido a que hay piezas pequenas, mantenga fuera del alcance a los ninos durante el ensamble, hasta que haya terminado.

MAINTENANCE TIPS

- Never let liquids or damp cloths sit on this furniture.
- Never use chemical cleaning products. They can damage the finish. For cleaning, use only a slightly damp cloth and wipe dry.
- To avoid dulling of the finish, do not place furniture in direct sunlight.
- Do not put plastic or rubber rings under appliances, Use cloth of felt protectors.
- To clean, use a soft or slightly damp cloth, then wipe with a clean, dry cloth.

- Ne jamais laisser de liquide ou linge humide sur le meuble.
- Ne jamais utiliser de nettoyeurs a base de produits chimiques, cela va endommager le fini. Utiliser seulement un linge legerement humide.
- Ne pas placer le meuble directement au soleil pour prevenir le ternissement.
- Evitez de déposer des appareils avec des rondelles de plastique ou de caoutchouc. Utilisez un protecteur en tissu ou en feutre.
- Pour nettoyer, utilisez un linge doux ou legerement humecte. Essayez par la suite avec un linge propre at sec.

- Nunca deje un liquido o un trapo humedo sobre el mueble.
- Nunca utilice limpiadores a base de quimicos, eatos danaran le acabado. Use solo un pano humedo.
- No esponga el mueble directamente al sol para prevenir empanamiento.
- Evite apoyar aparatos aparatos con redondeles de plastico o de goma. Utilizar un protector de tela o de fieltro.
- Para limpiar, utilice un trapo suave o ligeramente humedecido. Seque luego con un trapo limpio y seco.

 **WARNING** 
AVERTISSEMENT / ADVERTENCIA

Please use your furniture correctly and safely. Improper use can cause safety hazards, or damage to your furniture or household items.

Children have died from furniture tipover:

- ALWAYS install the anti-tip device provided.
- NEVER put a TV on this product.
- NEVER open more than one drawer at a time.
- DO NOT defeat or remove the drawer interlock system; it is an important stability and safety system.
- PLACE heaviest items in the lowest drawers.

Use of tip-over restraints reduce, but does not eliminate, the risk of tip-over.

Priere d' utiliser le mobilier a bon escient et avec prudence. Une mauvaise utilisation peut etre a l' origine de risques d' accident ou peut endommager le mobilier et les articles menagers.

Des enfants sont morts a cause du basculement de meubles. Pour reduire le risque de basculement des meubles:

- TOUJOURS installer le dispositif anti-basculement fourni.
- NE JAMAIS placer un televiseur sur ce produit.
- NE JAMAIS permettre aux enfants d' etre dessus, de grimper, ou de se pendre apres des tiroirs, portes ou etageres.
- NE JAMAIS ouvrir plus d' un tiroir a la fois
- NE PAS defaire ou retirer le systeme de verrouillage du tiroir; il s'agit d' un important systeme de stabilite et de securite.
- PLACEZ les articles les plus lourds dans les tiroirs plus bas.

L'utilisation de dispositif antibasculement ne peut que reduire les risques de basculement, sans les eliminer

Por favor use el mobiliario correcta y seguramente. El mal uso puede causar riesgos de seguridad o dano a las unidades o articulos domesticos.

Ninos han muerto por volcamiento de muebles. Para reducir el riesgo de que los muebles se vuelquen:

- SIEMPRE instale el dispositivo antivuelco suministrado.
- NUNCA coloque un televisor sobre este producto.
- NUNCA permita que los ninos se paren, trepen, o cuelguen de los cajones, puertas o estantes.
- NUNCA abra mas de un cajon a la vez.
- NO anule ni retire el sistema de bloqueo de los cajones; es un importante sistema de estabilidad y seguridad.
- COLOQUE los articulos mas pesados en cajones de abajo.

El uso de sujetadores para evitar el vuelco solo puede disminuie el riesgo de un vuelco, pero no lo elimina.

MINIFIX CAM & MINIFIX BOLT & WOOD DOWEL
CAMÉRA MINIFIX & BOULON MINIFIX & CHEVILLE BOIS
CÁMARA MINIFIX & PERNO MINIFIX & PASADOR DE MADERA

MINIFIX BOLT
BOULON MINIFIX
PERNO MINIFIX



MINIFIX CAM
CAMÉRA MINIFIX
CÁMARA MINIFIX









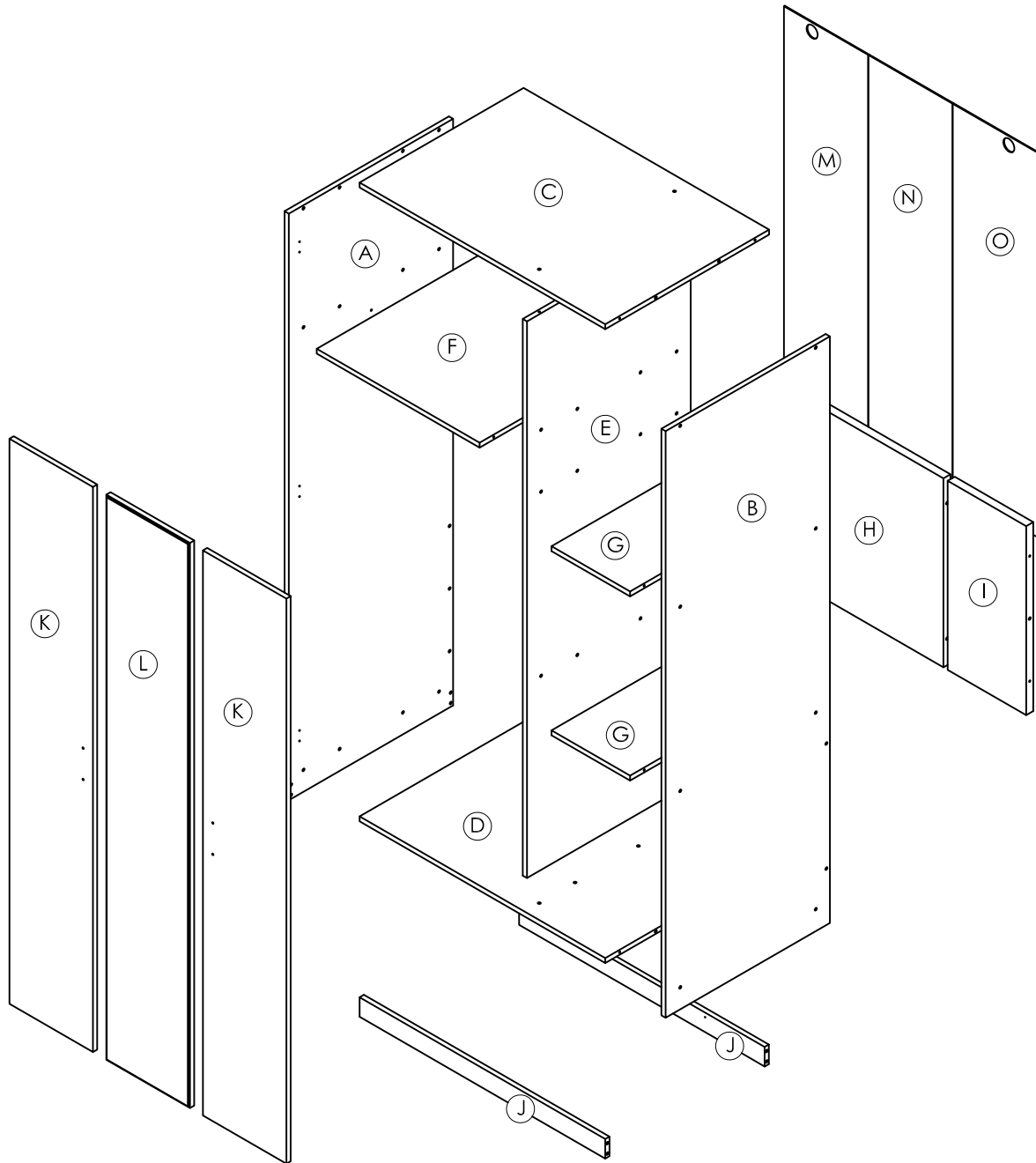



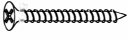



WOOD DOWEL
CHEVILLE BOIS
PASADOR DE MADERA



PARTS IDENTIFICATION
IDENTIFICATION DES PIÈCES
IDENTIFICACION DE LAS PARTES







HARDWARE QUINCAILLERIE / HERRAJE

(1)	DOWEL Ø8 X 30MM  38 Pcs	(2)	SCREW M4.7 x 38MM  2 Pcs	(3)	SCREW M3.5 x 15MM  14 Pcs	(4)	SCREW M4 x 30MM  4 Pcs
(5)	T-SCREW M10 X 12MM  38 Pcs	(6A)	METAL HINGES 5/8  6 Pcs	(6B)	METAL PLATE  6 Pcs	(7A)	METAL HINGES 2/8  3 Pcs
(7B)	METAL PLATE  3 Pcs	(8)	PLASTIC HANDLE 96MM  2 Pcs	(9)	PLASTIC U-BRACKET  2 Pcs	(10)	METAL HANGER-569  1 Pc
(11)	METAL L BRACKET 2MM  4 Pcs	(12)	NAIL PIN  18 Pcs	(13)	UNITAR SCREW M6.3x40MM  28 Pcs	(14)	NAIL LEG  3 Pcs

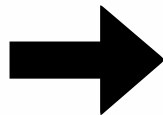
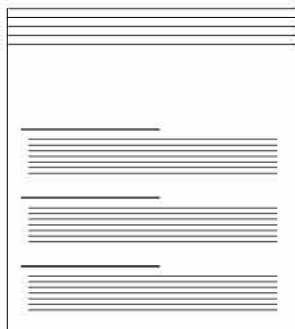
- Hardware quantity may supplied more than it required. Please keep spares and tools for future use.
- La cantidad de hardware puede suministrarse mas de lo requerido. Guarde los repuestos y las herramientas para uso futuro.
- La quantite de materiel peut fournir plus que necessaire. Veuillez conserver les pieces de rechange et les outils pour une utilisation future.

FURNITURE TIPPING RESTRAINT SEGURO CONTRA VOLCADO DE MUEBLES DISPOSITIF DE SECURITE POUR MEUBLES

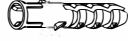

(15)	MOUNTING L-BRACKET  2 Pcs	(16)	WALL PLUG  2 Pcs
(17)	WASHER  2 Pcs	(18)	ALLEN KEY  1 Pcs

TOOLS NOT INCLUDED OUTILS PAS INCLUS / HERRAMIENTAS NO INCLUIDAS

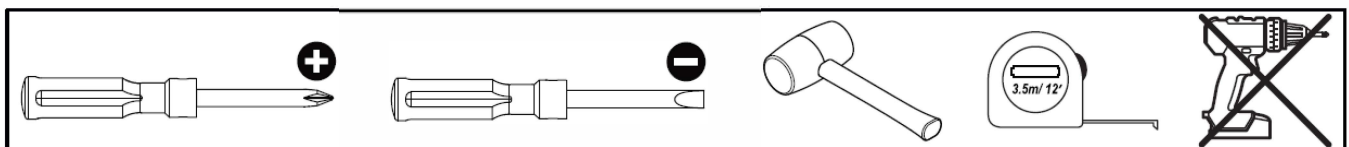

STEP 1

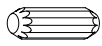
(1)	DOWEL Ø8X30MM	H	I	D	C	F	G	E	J
		3	3	4	4	4	8	4	8
	38 Pcs								

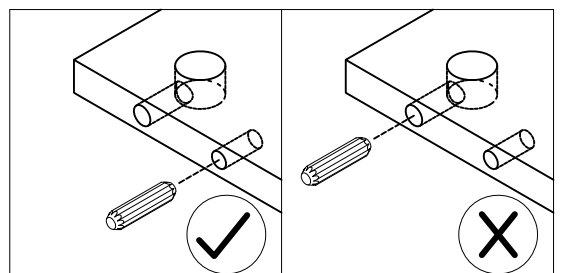
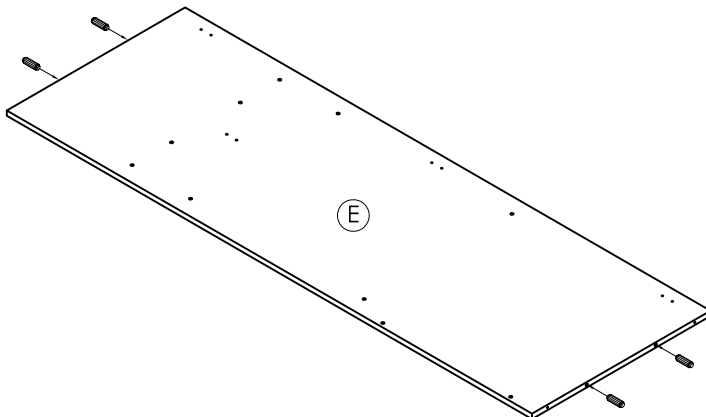
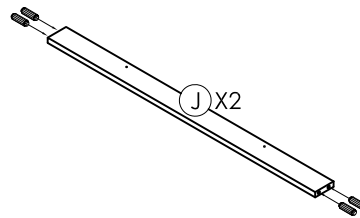
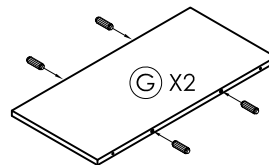
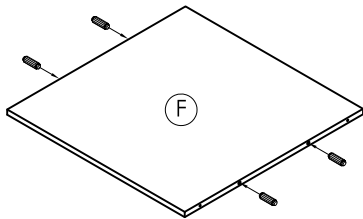
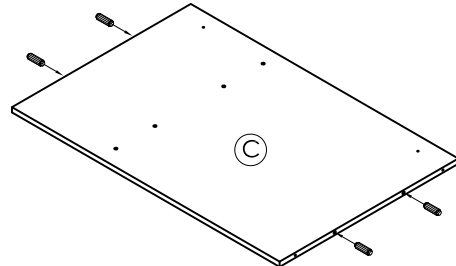
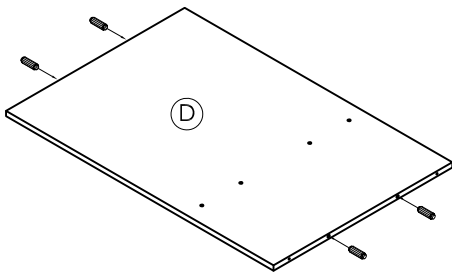
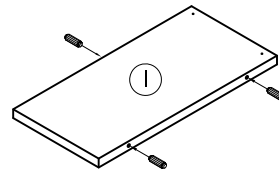
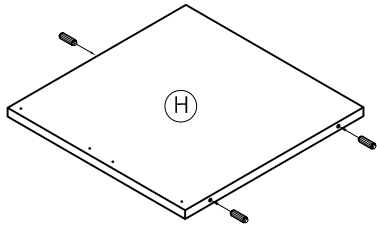

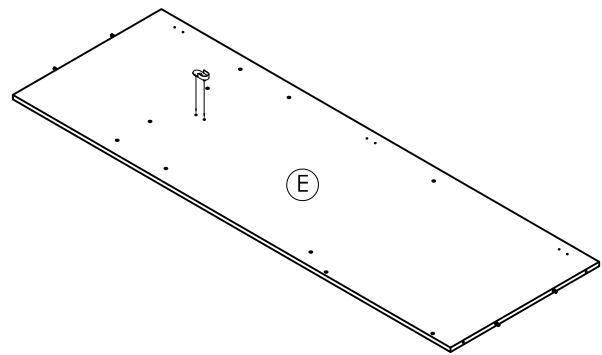
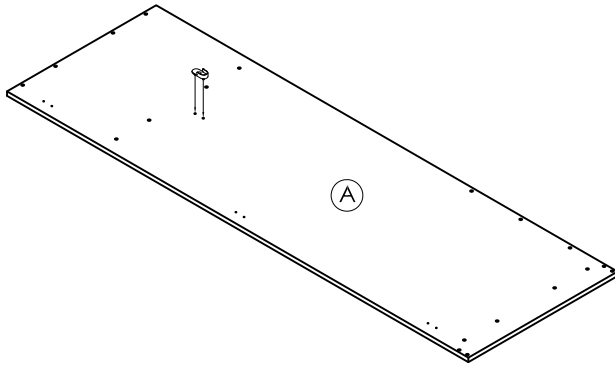

STEP 2

(9)	PLASTIC U-BRACKET	A	E
		1	1
	2 Pcs		



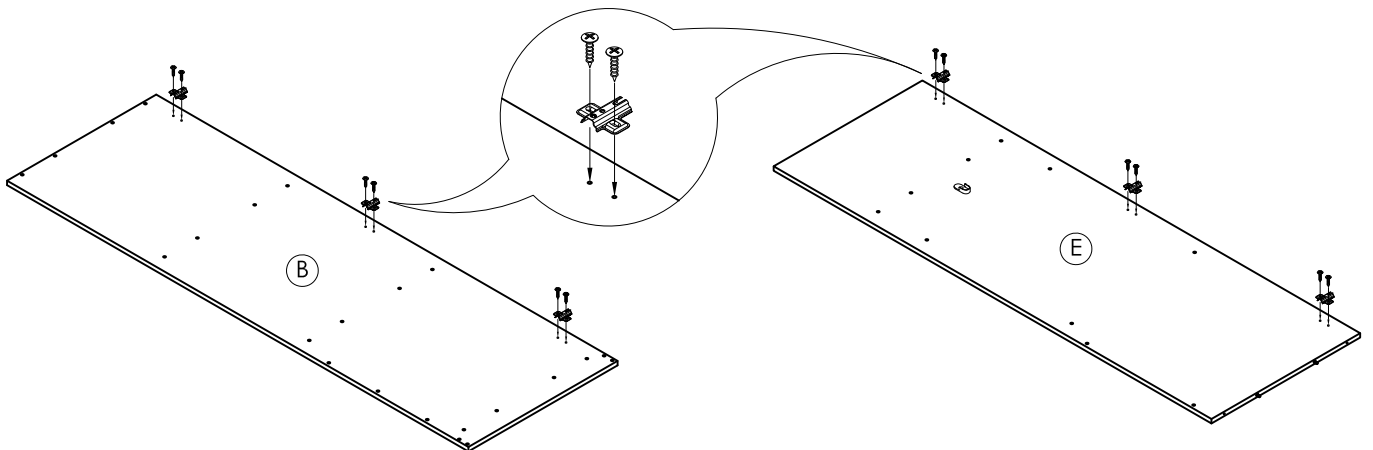
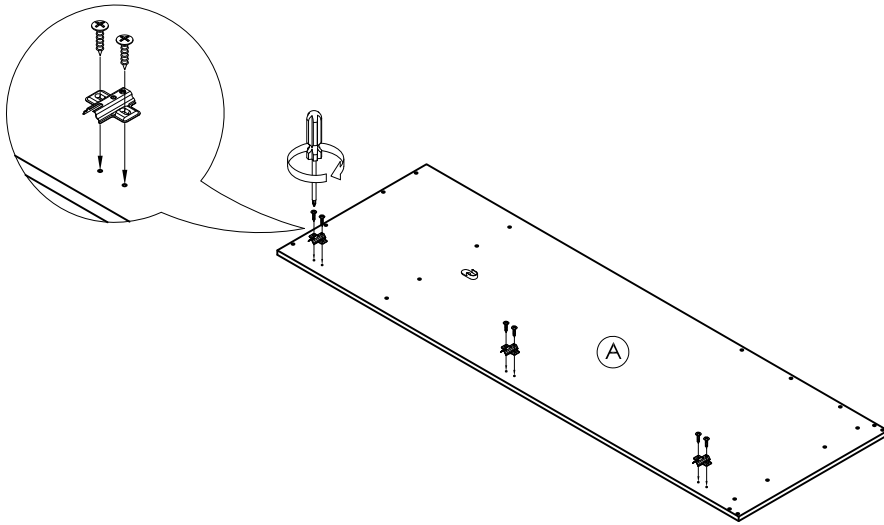

STEP 3

(5)	T-SCREW M10 X 12MM	A	B	E
		6	6	6
	18 Pcs			
(6B)	METAL PLATE	A	B	
		3	3	
	6 Pcs			
(7B)	METAL PLATE		E	
			3	
	3 Pcs			

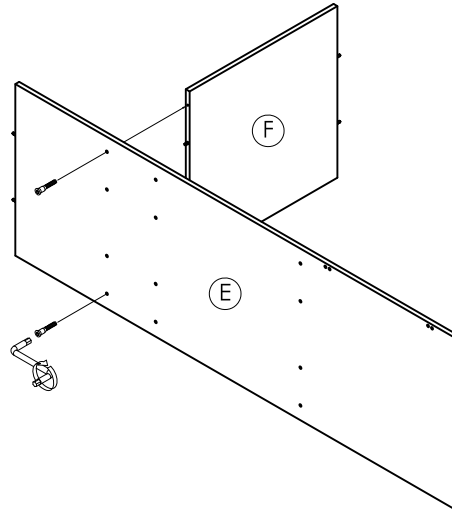

STEP 4

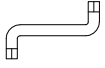

(13)	UNITAR SCREW M6.3x40MM	E
		
2 Pcs		
(18)	ALLEN KEY	
		
1 Pc		

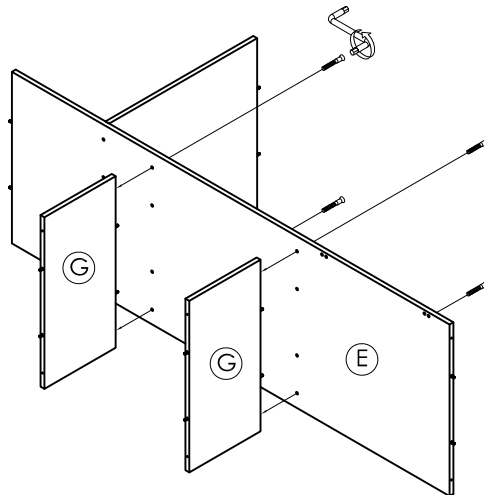

STEP 5

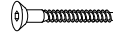

(13)	UNITAR SCREW M6.3x40MM	E
		
4 Pcs		

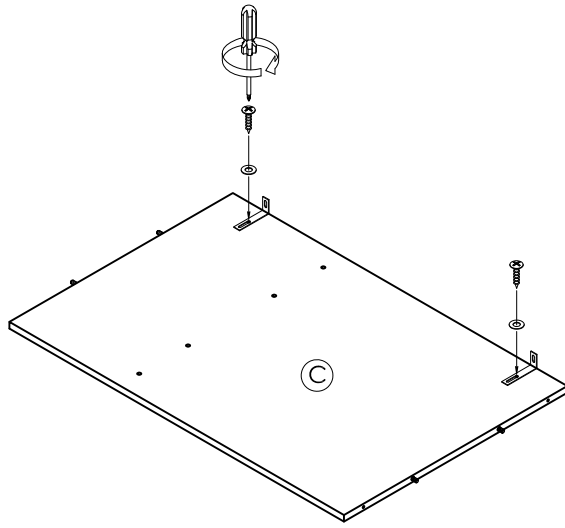
STEP 6



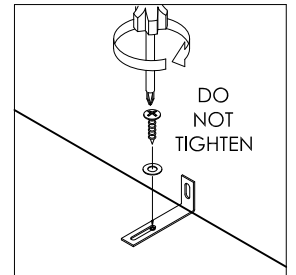

(5)	T-SCREW M10 X 12MM	C
		2
2 Pcs		
(15)	MOUNTING L-BRACKET	C
		2
2 Pcs		
(17)	WASHER	C
		2
2 Pcs		

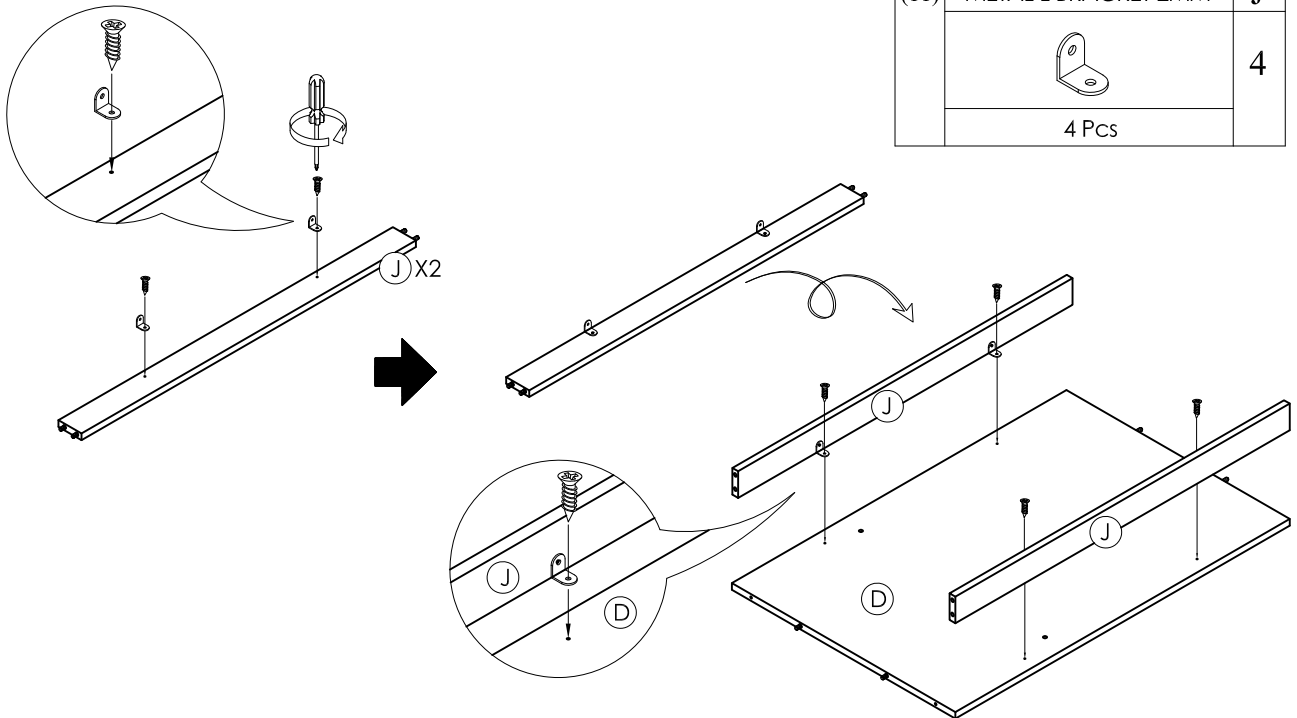

STEP 7



(3)	SCREW M3.5 x 15MM	J	D
		4	4
8 Pcs			
(11)	METAL L BRACKET 2MM	J	
		4	
4 Pcs			

STEP 8

(13)	UNITAR SCREW M6.3x40MM	C	D
		2	2
	4 Pcs		

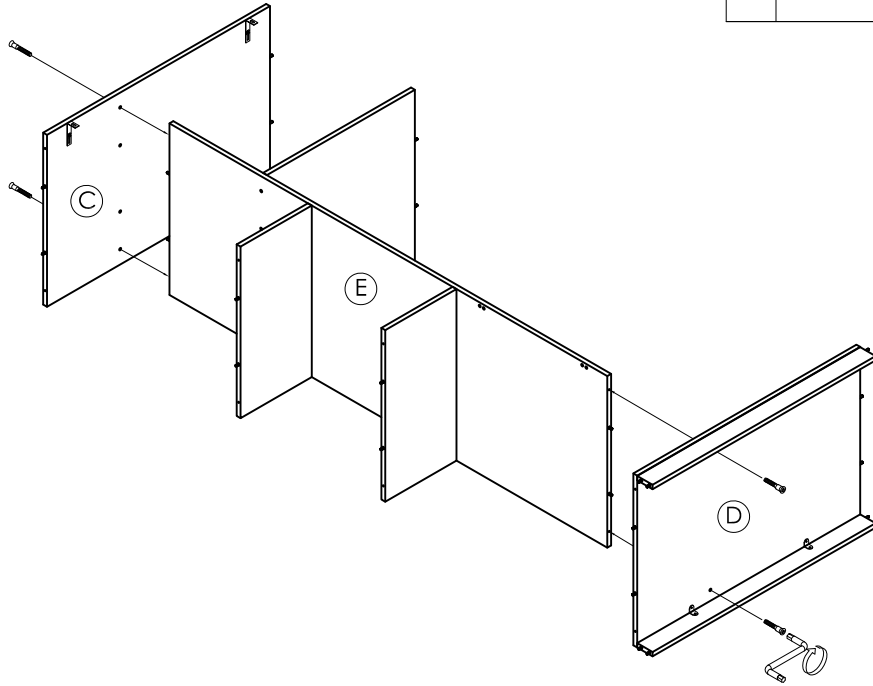

STEP 9

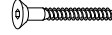
(13)	UNITAR SCREW M6.3x40MM	B
		10
	10 Pcs	

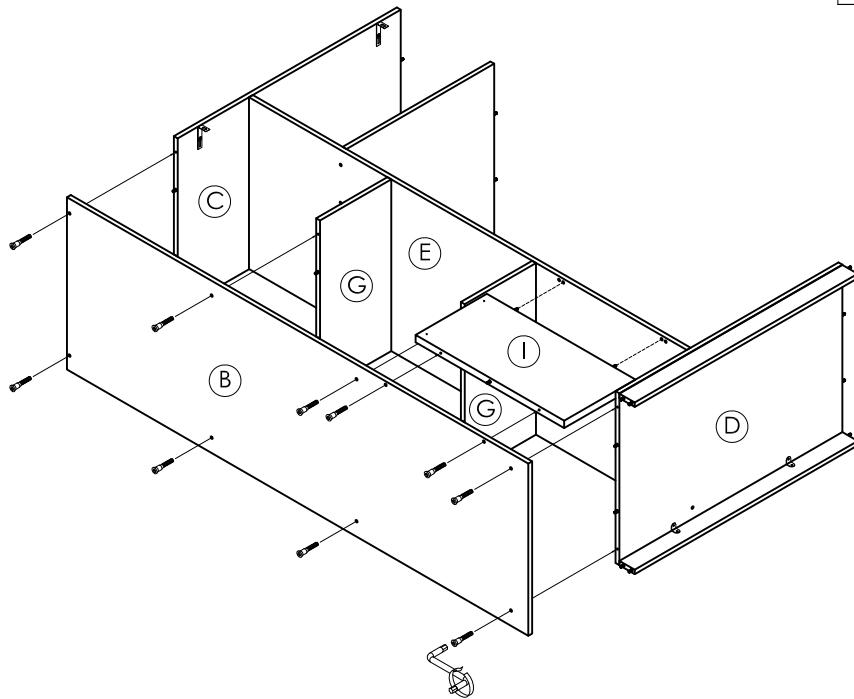

STEP 10

(13)	UNITAR SCREW M6.3x40MM	A
		8
	8 Pcs	

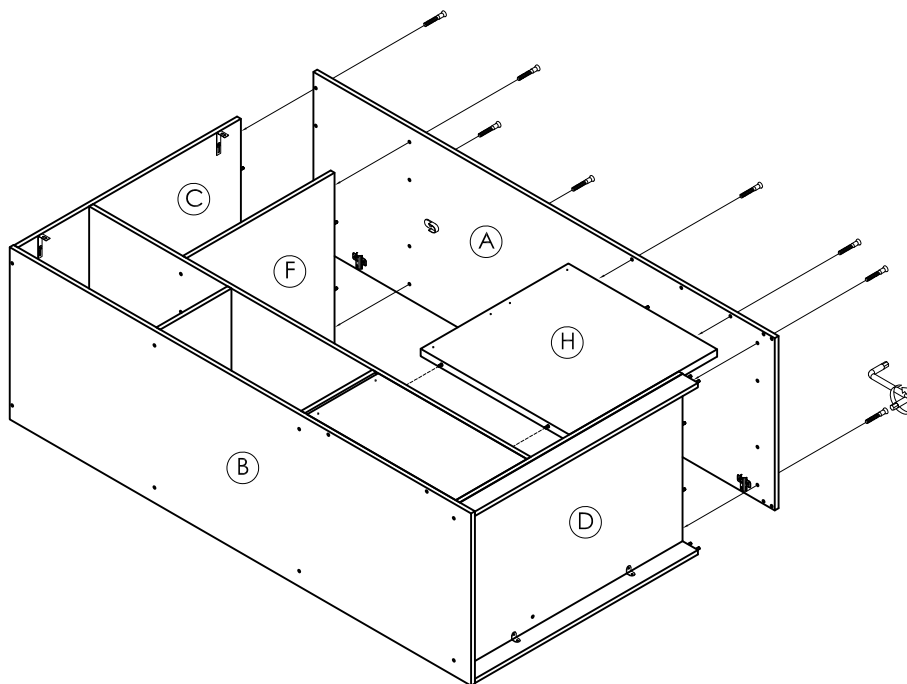

STEP 11

(3)	SCREW M3.5 x 15MM	M	N	O
		2	2	2
	6 Pcs			

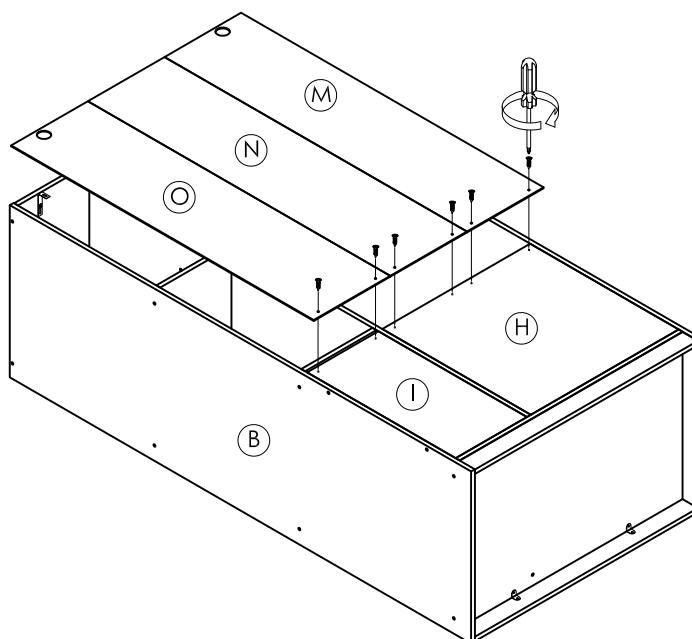

STEP 12

(12)	NAIL PIN	M	N	O
		7	4	7
	18 Pcs			

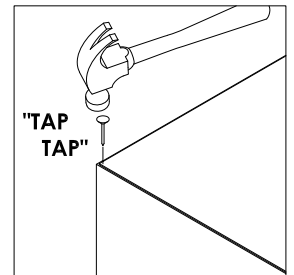
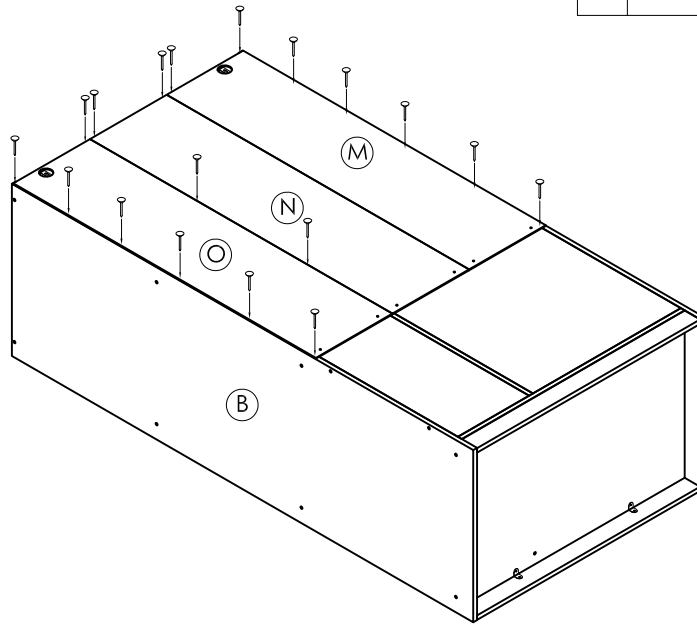

STEP 13

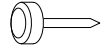
(14)	NAIL LEG	A	B	J
		1	1	1
	3 Pcs			

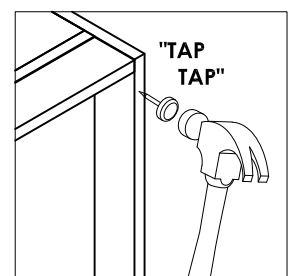
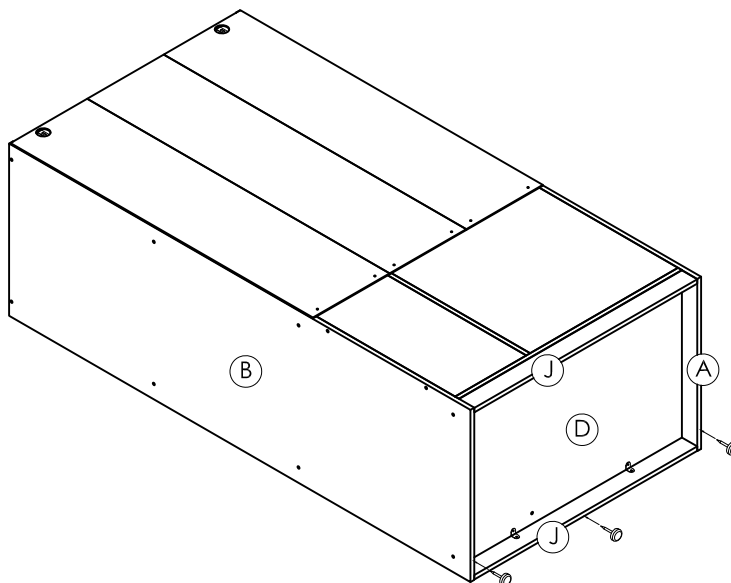

FURNITURE TIPPING RESTRAINT

SEGURO CONTRA VOLCADO DE MUEBLES

DISPOSITIF DÉ SÉCURITÉ POUR MEUBLES

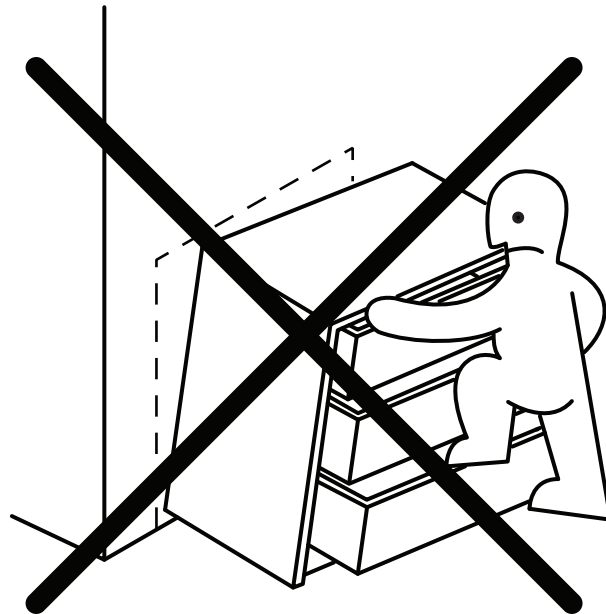
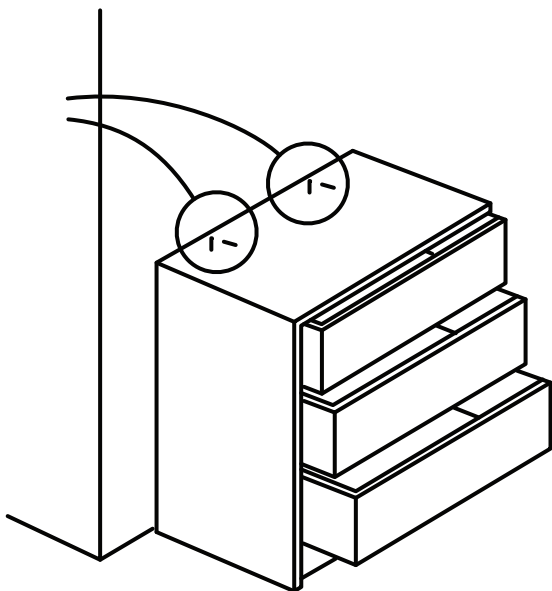

STEP 14

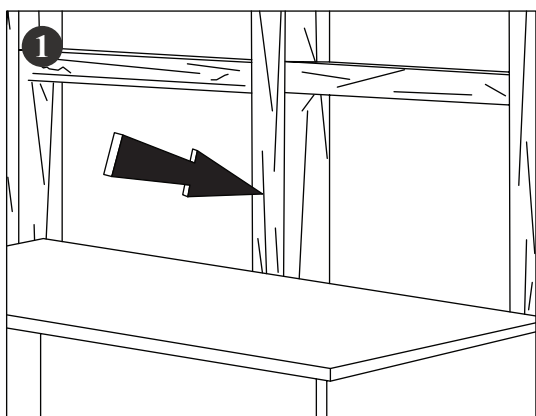

Locate a wall stud:

- Move the furniture unit to its final position to the wall
- Locate a wall stud behind the furniture unit

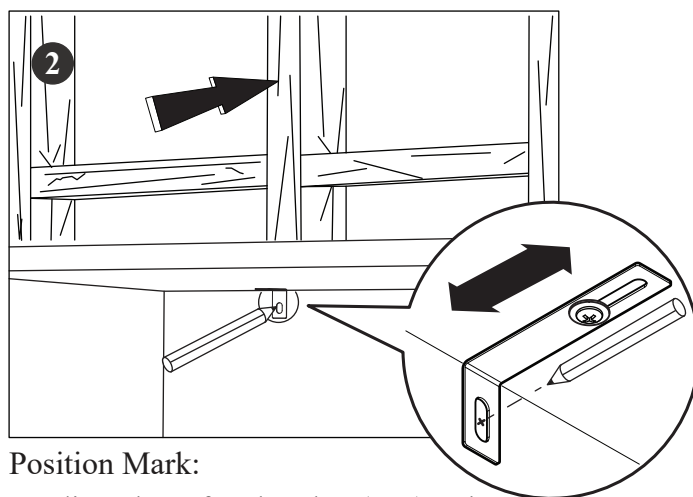

Position Mark:

- Adjust the safety bracket (AA) to be flush to the wall
- Use the Pencil to mark the positioning hole on a wall stud

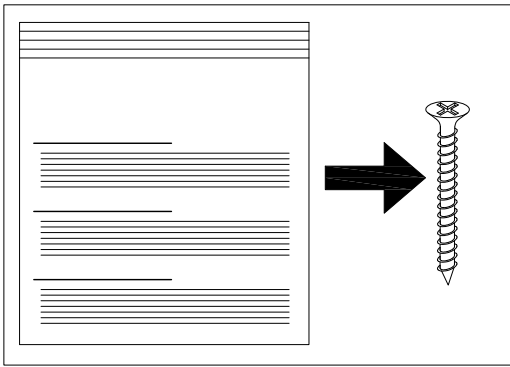

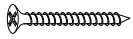
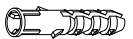
(2)	SCREW M4.7 x 38MM
	
	2 Pcs
(16)	WALL PLUG
	
	2 Pcs

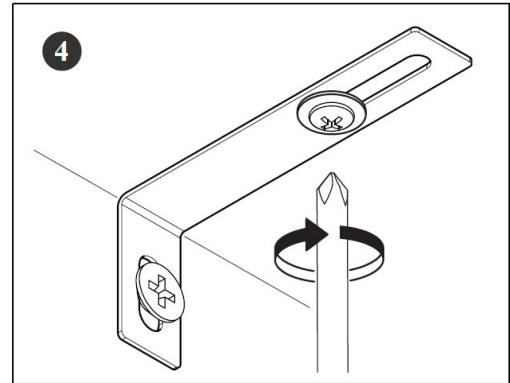
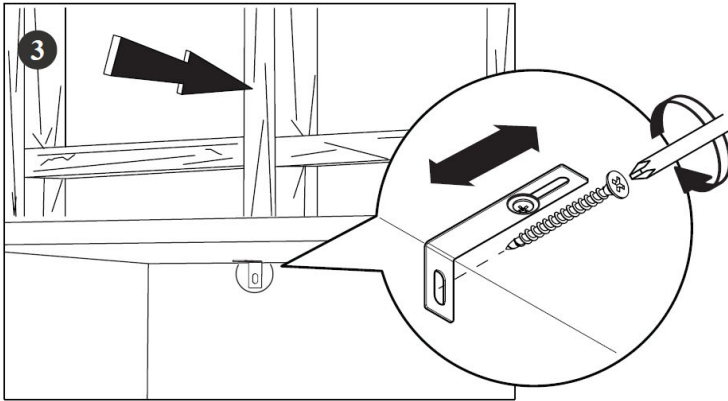

Screw the safety bracket to the wall stud:
 – Screw the safety bracket (AA) to the wall stud with Screw (DD)

Adjust the furniture:
 – Tighten back the screw (CC) to secure the furniture to be locked to the wall

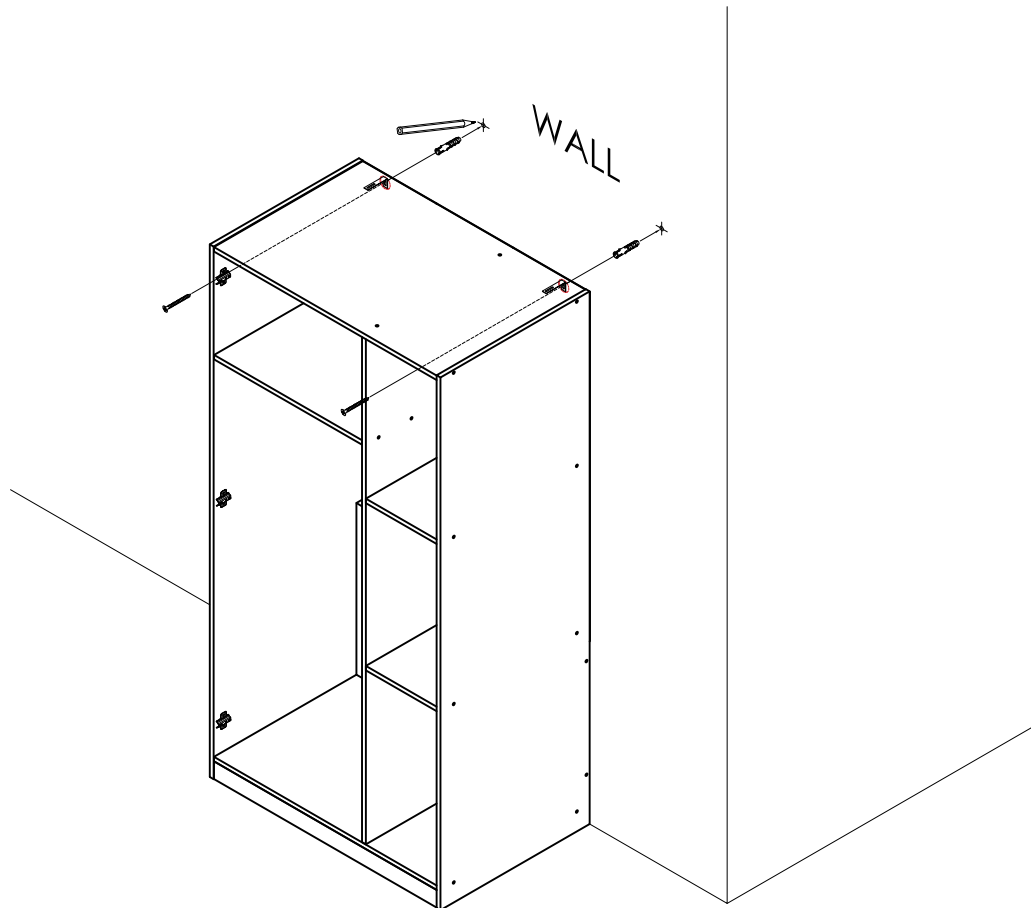

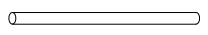

STEP 15

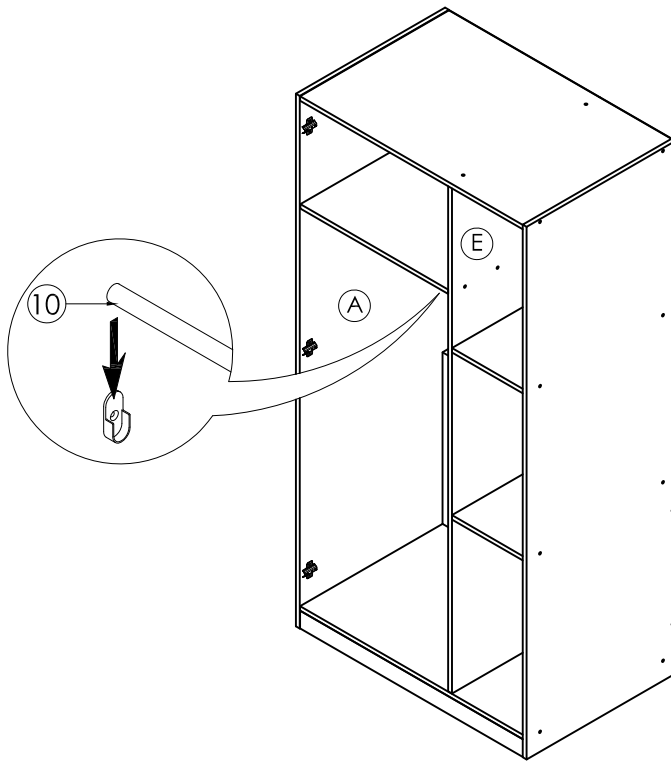
(10)	METAL HANGER-569
	
	1 Pc

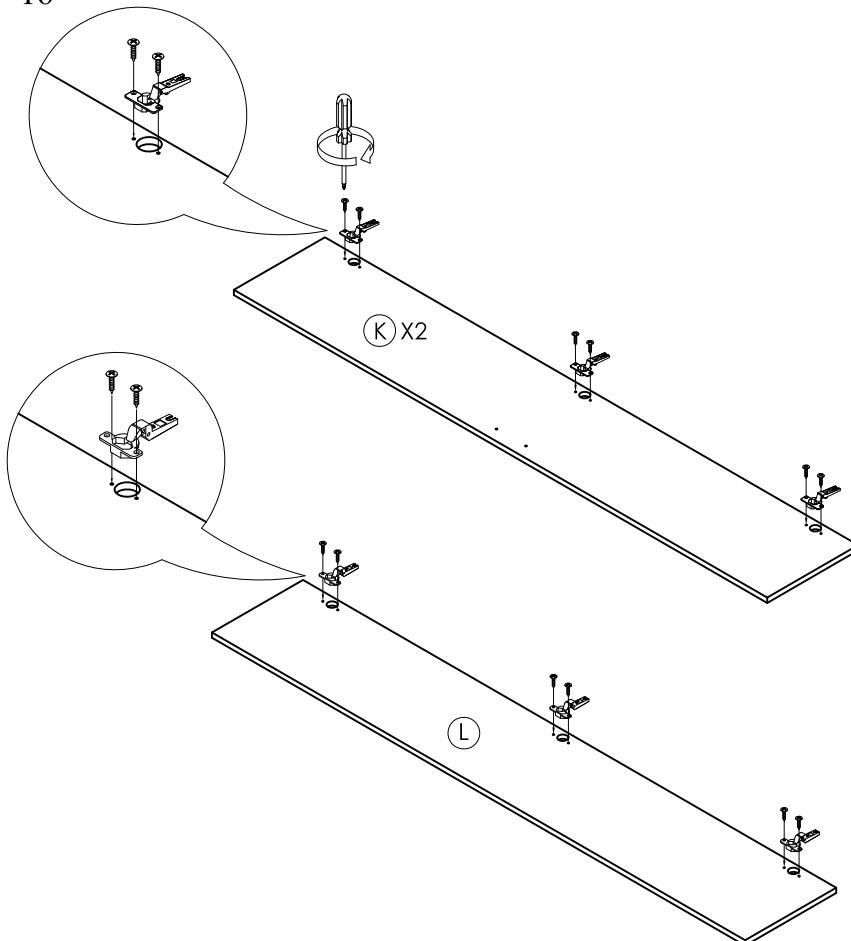

STEP 16

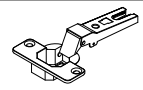
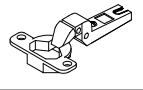

(5)	T-SCREW M10 X 12MM	K	L
		12	6
	18 Pcs		
(6A)	METAL HINGES 5/8	K	
		6	
	6 Pcs		
(7A)	METAL HINGES 2/8	L	
		3	
	3 Pcs		

STEP 17

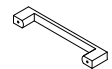
(4)	SCREW M4 x 30MM	K
		4
4 Pcs		
(8)	PLASTIC HANDLE 96MM	K
		2
2 Pcs		

