

ASSEMBLY INSTRUCTION

WF300332

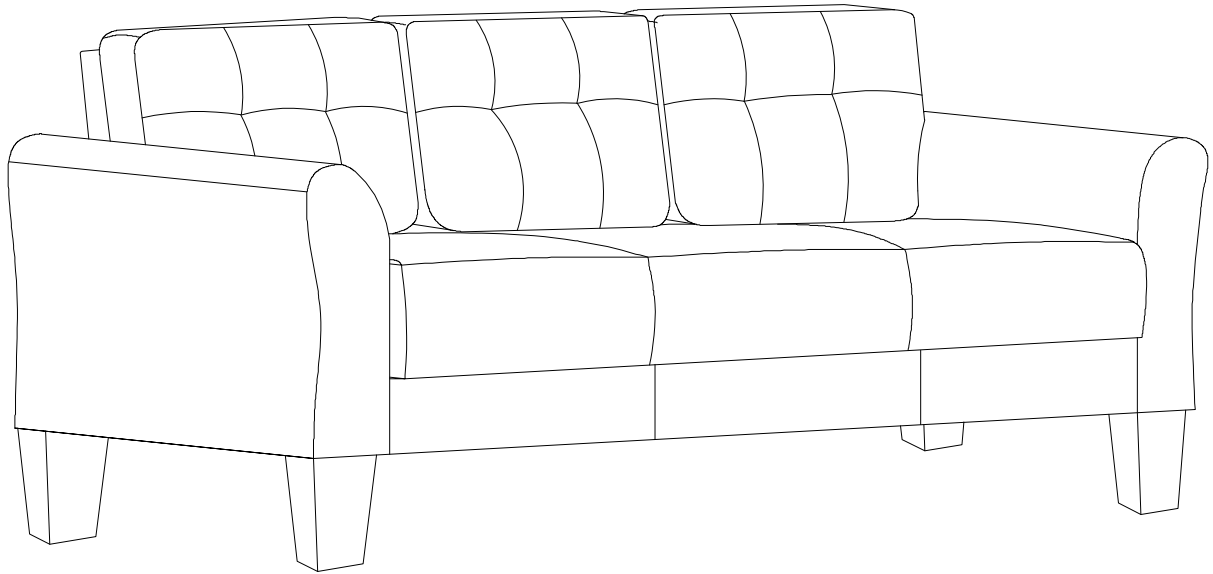

PARTS

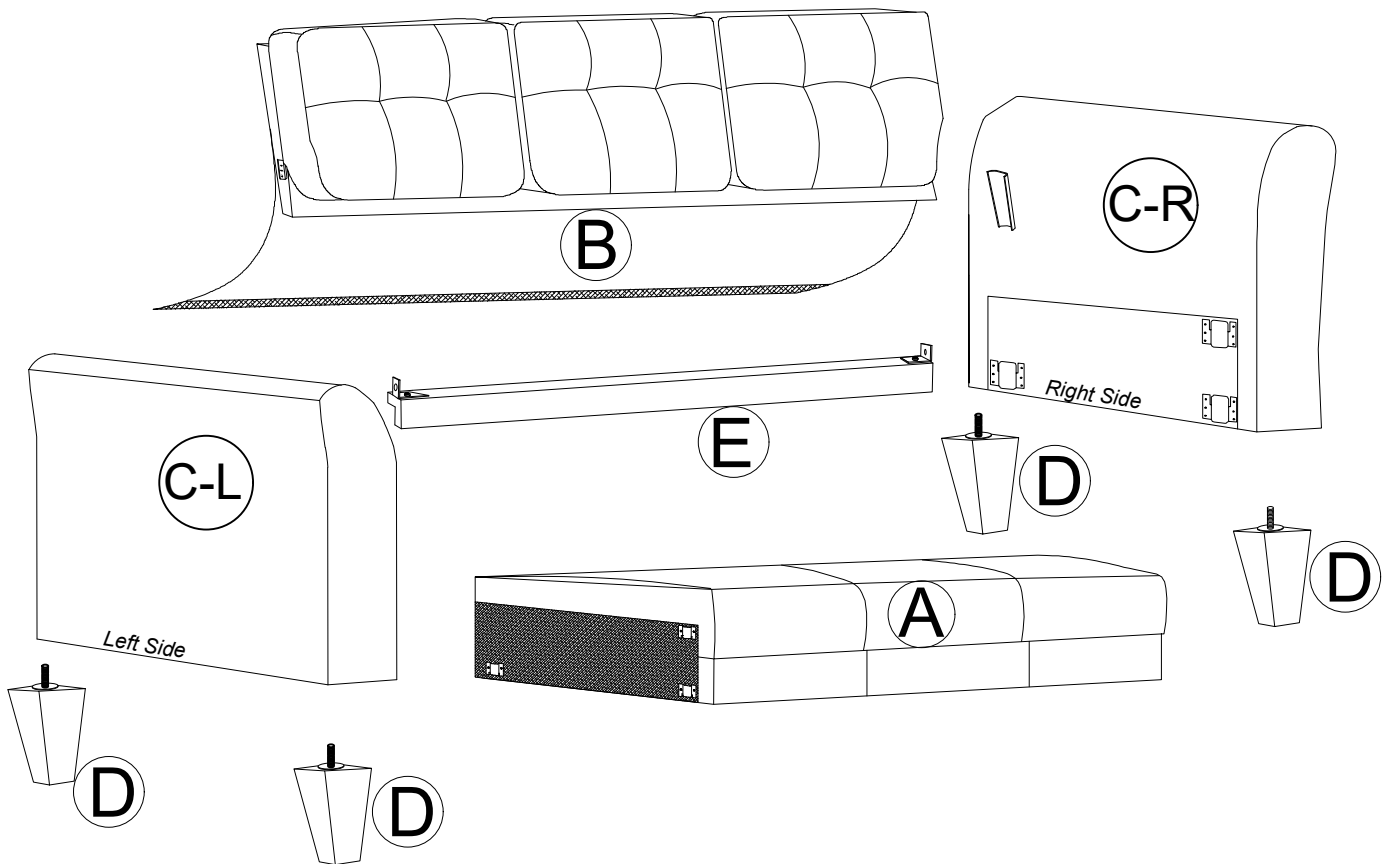

WF300332 - COMPONENT LIST

A

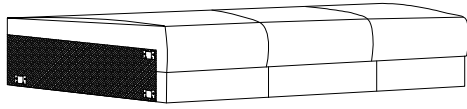

SEAT BODY
QTY: 1PC

B

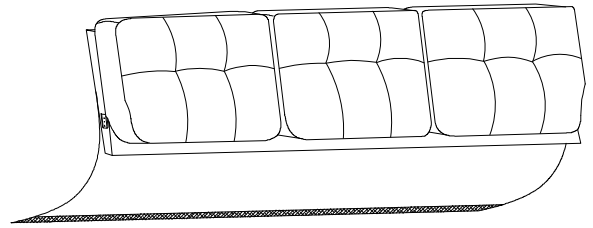

BACK REST
QTY: 1PC
(In the storage underneath of seat body)

C-L

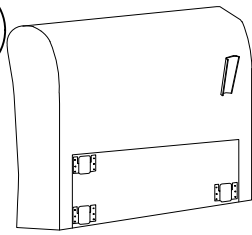

LEFT ARM
QTY: 1PC

C-R

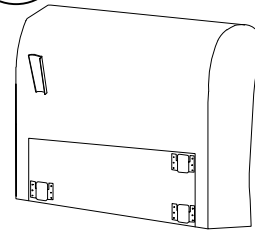

RIGHT ARM
QTY: 1PC

D

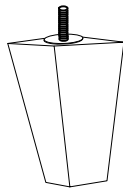

PLASTIC LEGS
QTY: 4PCS

E

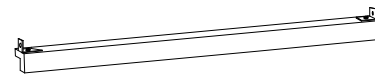

METAL SUPPORT
QTY: 1PC

HARDWARE (in box WF300332)

F

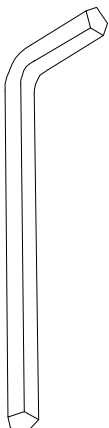

ALLEN KEY
QTY: 1PC

G

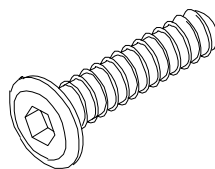

BOLT Ø1/4"x20MM
QTY: 2PCS

H



FLAT WASHER
QTY: 2PCS

Step 1:

Remove the hardware and the leg box from packet.
Place all parts on a clean, smooth surface.

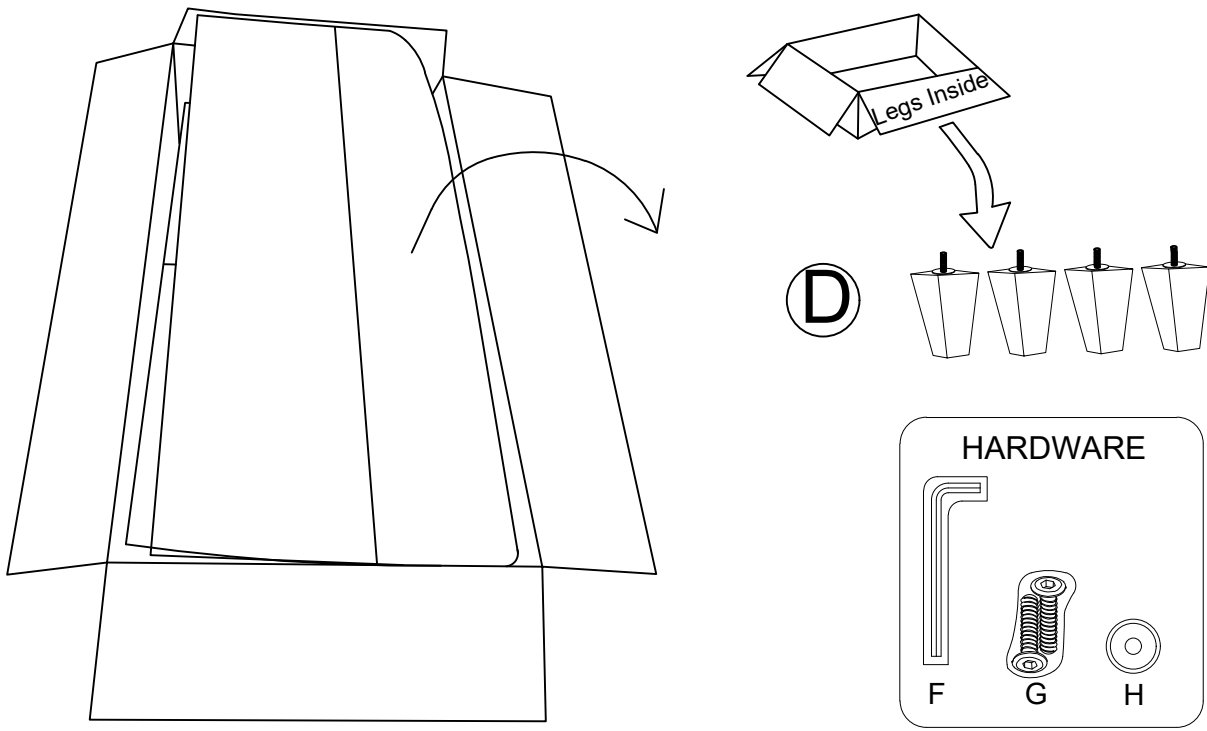

Step 2:

Manually legs D x 2 to C-R/C-L , as shown.

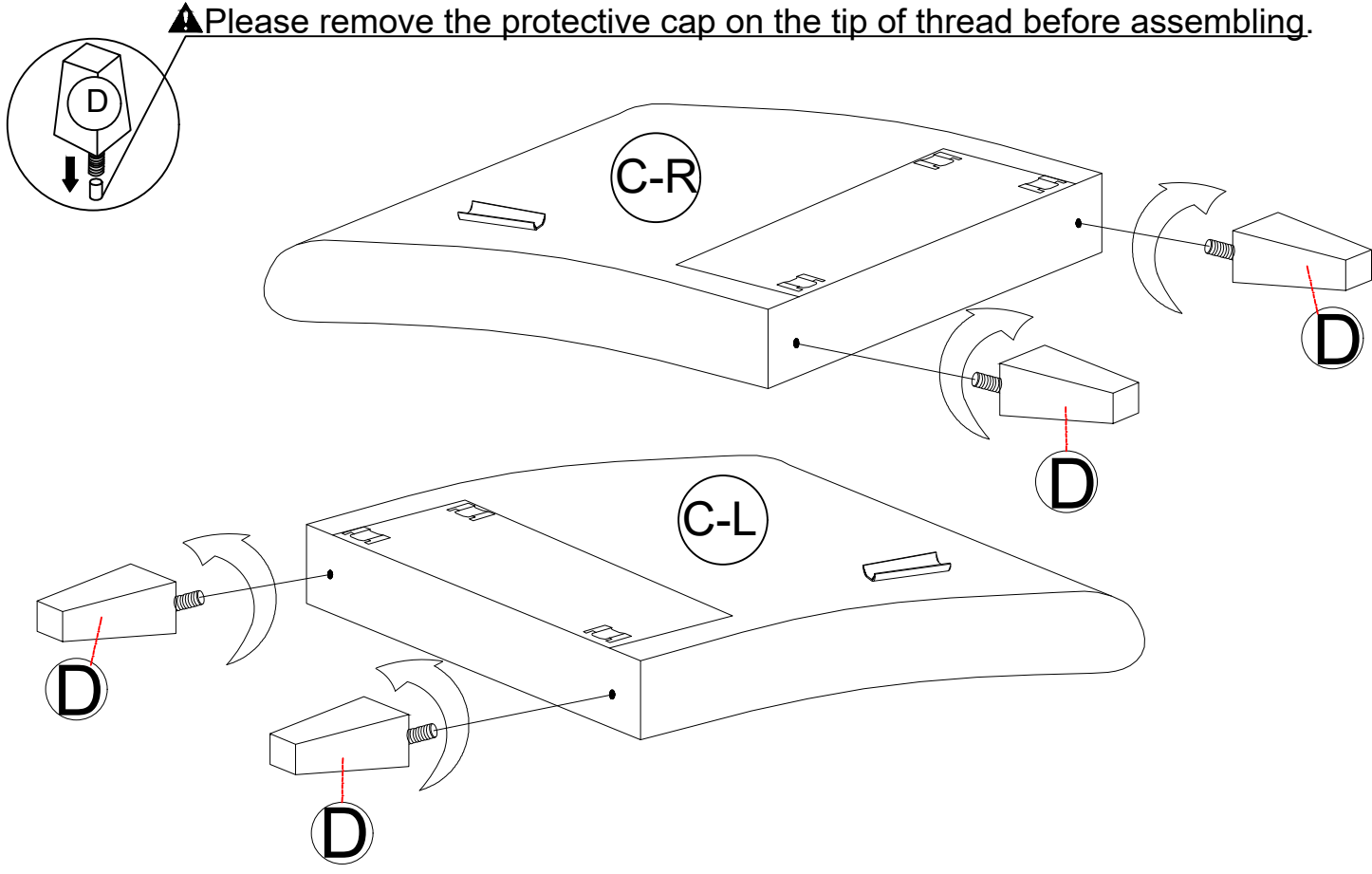

Step 3:

Attach C-R/C-L to A by inserting C-R/C-L into the metal glides on A. Push C-R/C-L with A downward force to secure it into place.

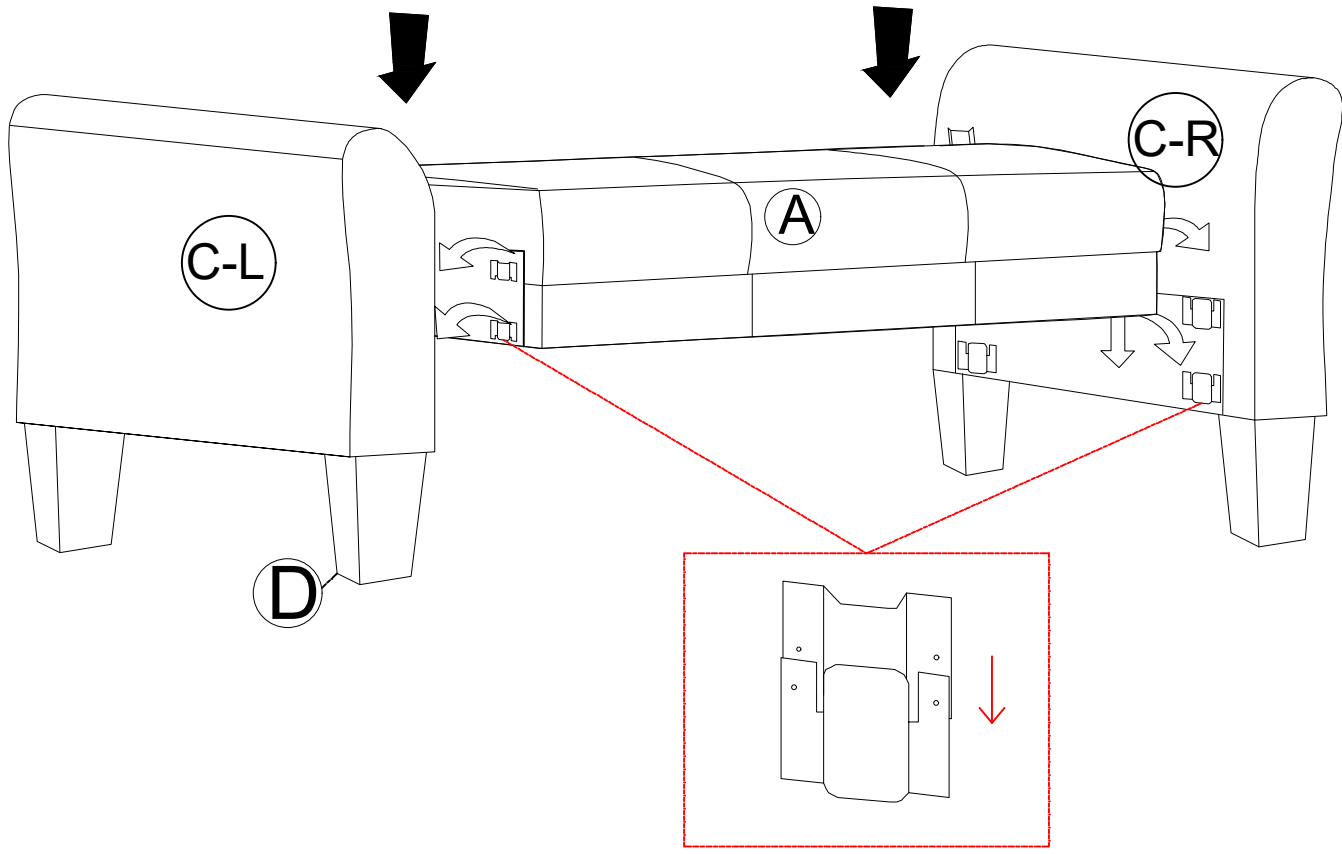

Step 4:

Attach B to C-R/C-L by inserting B into the metal glides on C-R/C-L. Push B with C-R/C-L downward force to secure it into place.

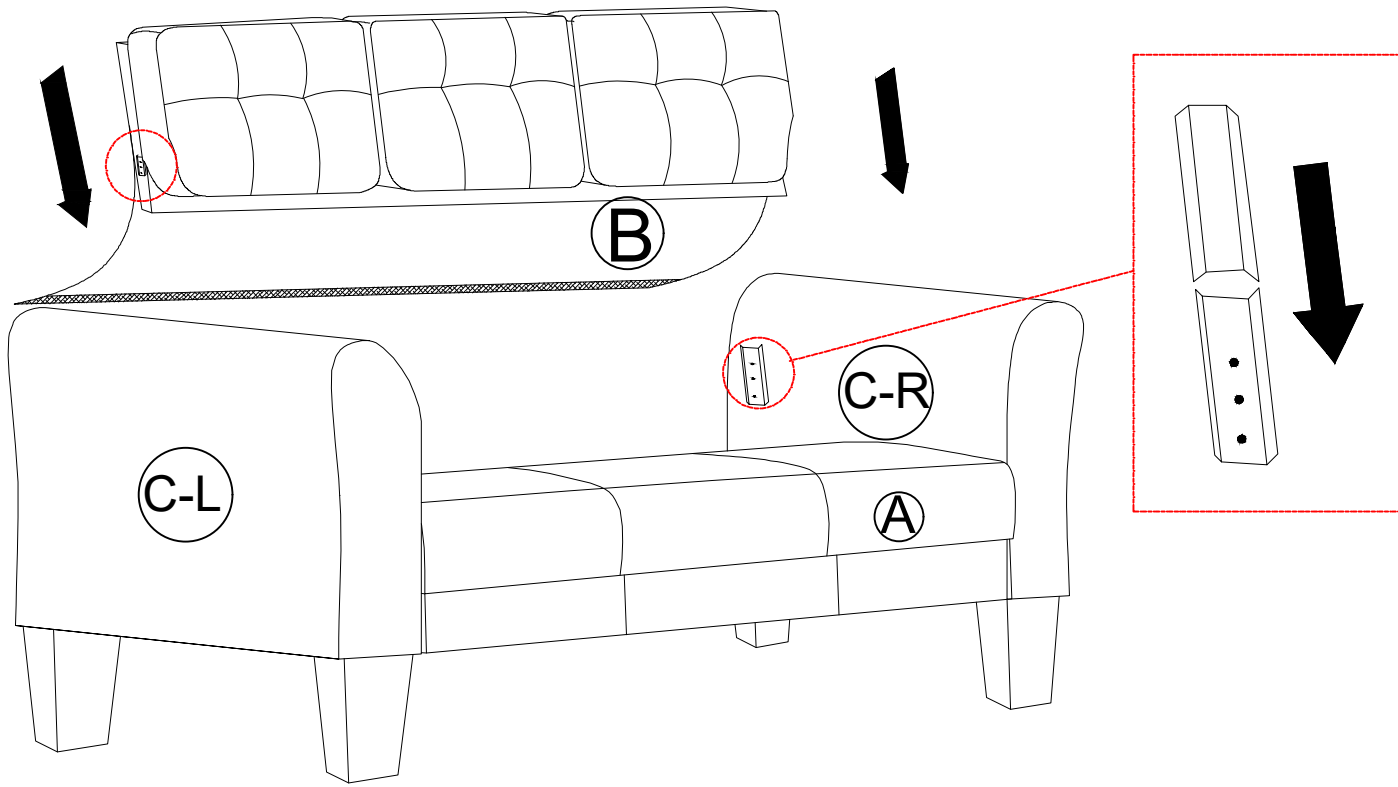

Step 5:

Turn to the back, fix E to the back rest by using F, G and H.

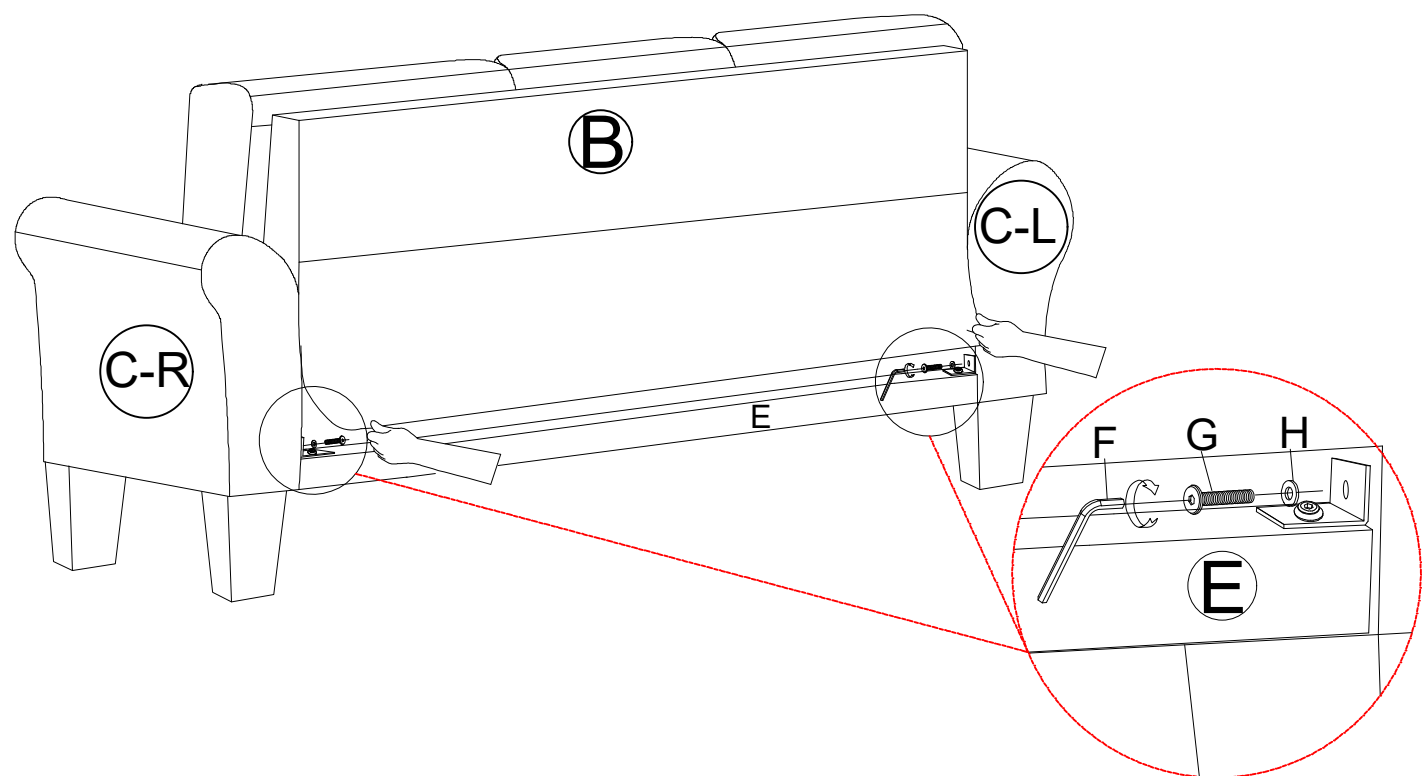

Step 6:

Stretch and pull down rear cover evenly before securing velcro strip to seat base.

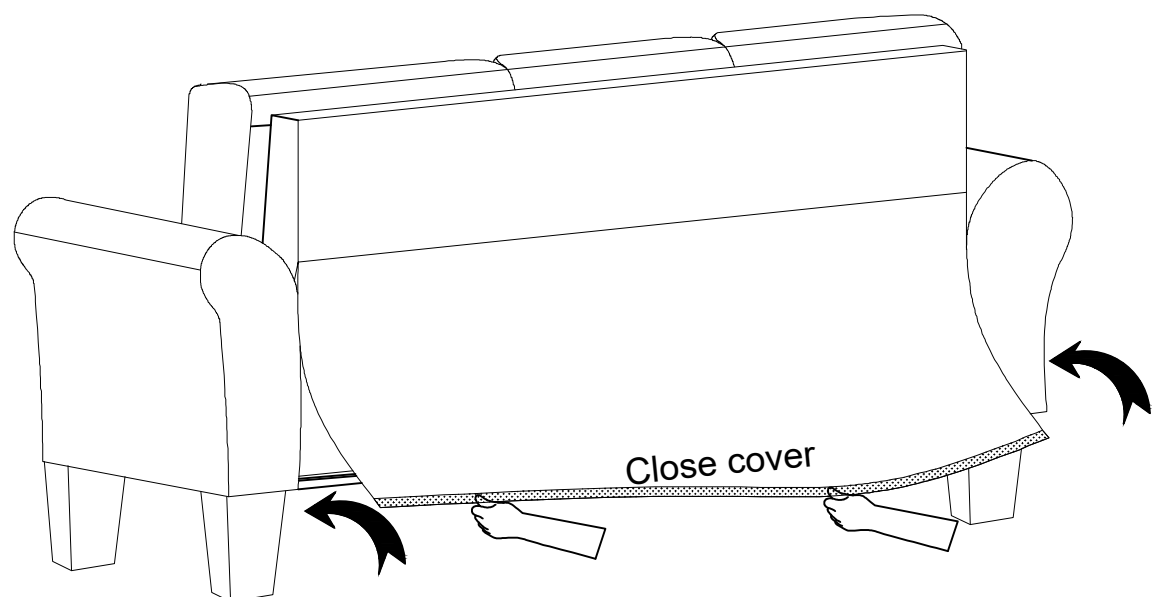

BACK VIEW

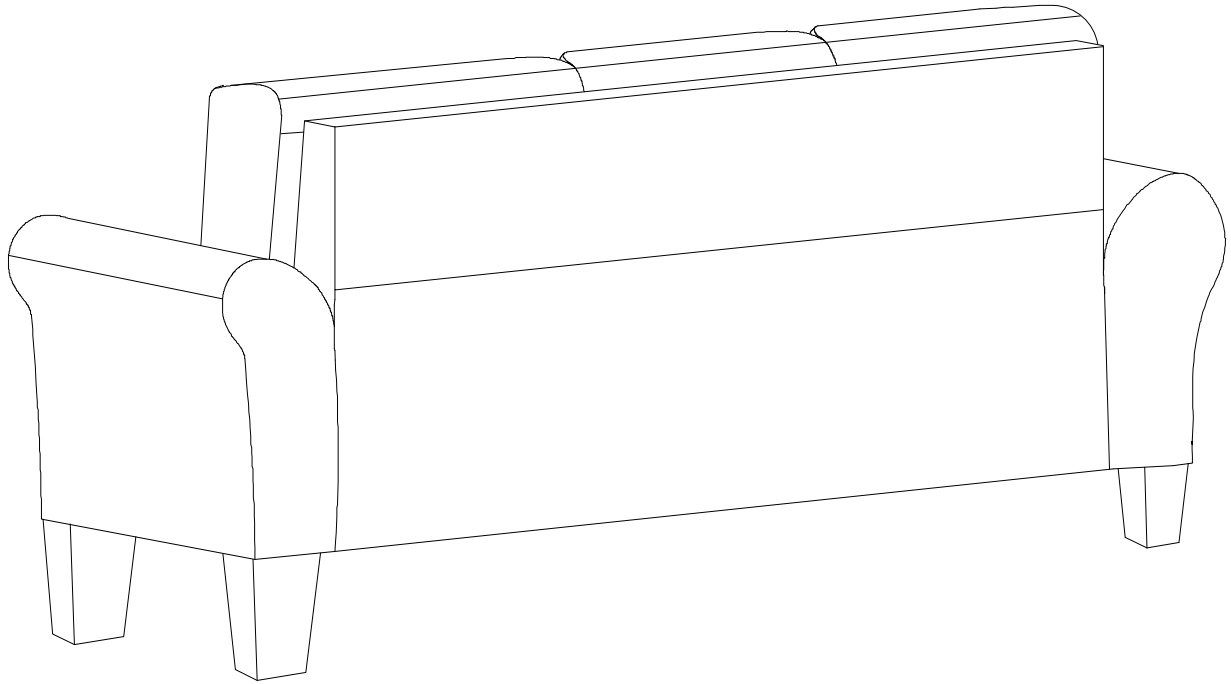

FRONT VIEW

