

# Rattan Adjustable Cylinder Sofa

---

If you have any questions about the rattan adjustable cylinder sofa , please feel free to contact us.

Customer Service Email: [Service@alaulm.com](mailto:Service@alaulm.com)

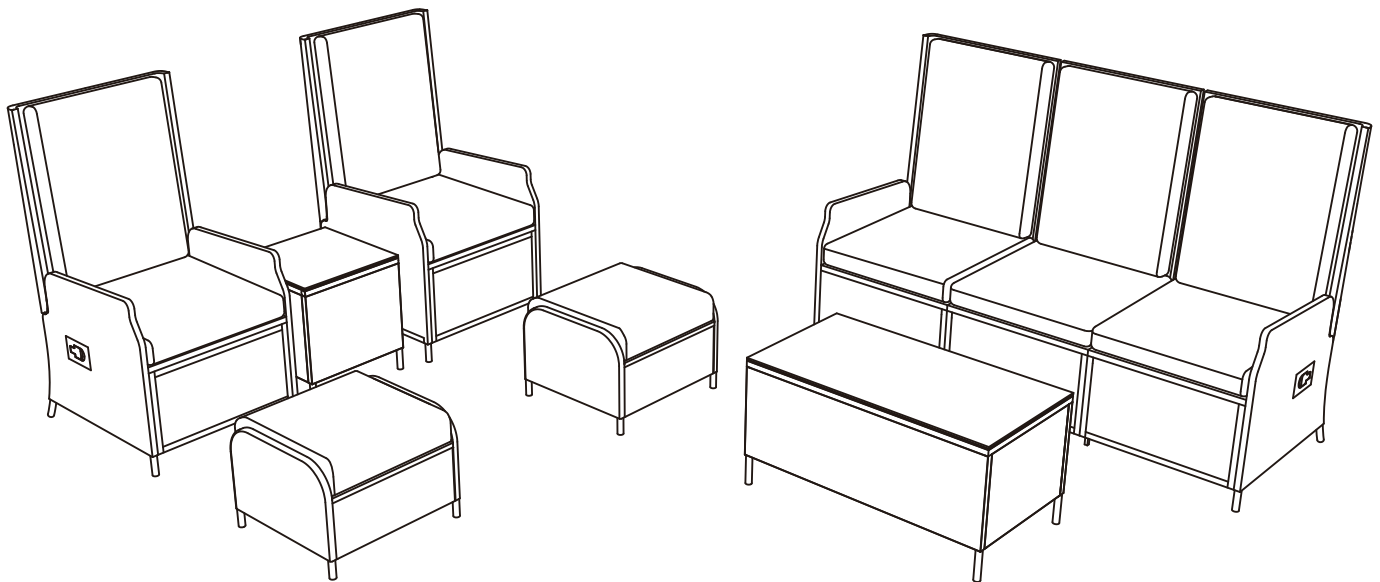

## 24-P019

### IMPORTANT

PLEASE READ BEFORE YOU COMMENCE ASSEMBLY

Follow the guidelines in this user guide to ensure correct  
assembly and care for this product.

# SPECIFICATIONS

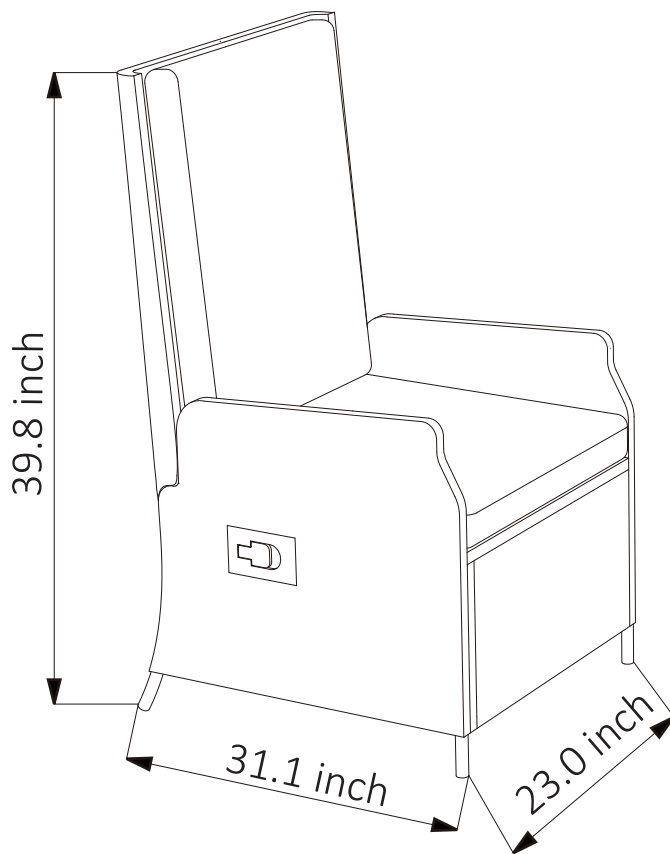
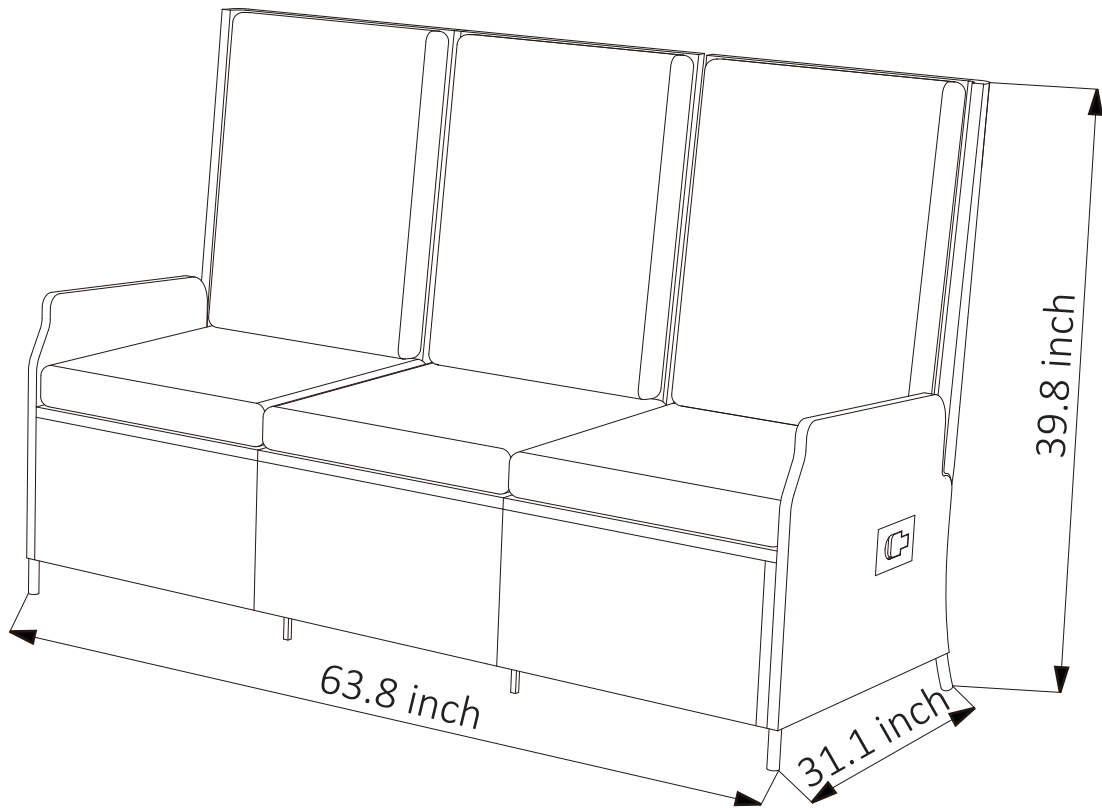

# SPECIFICATIONS

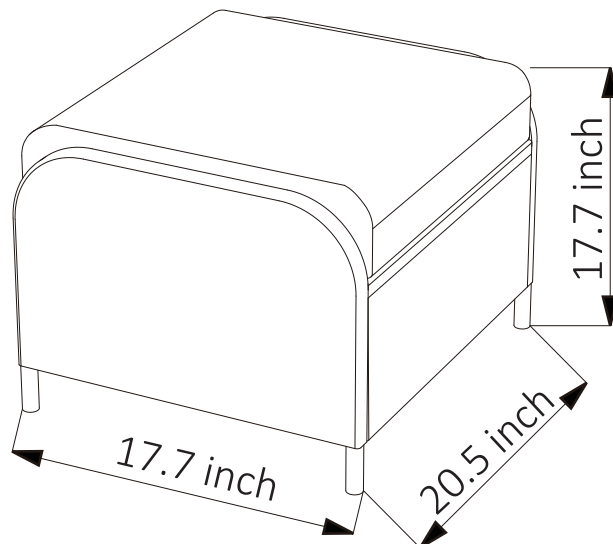
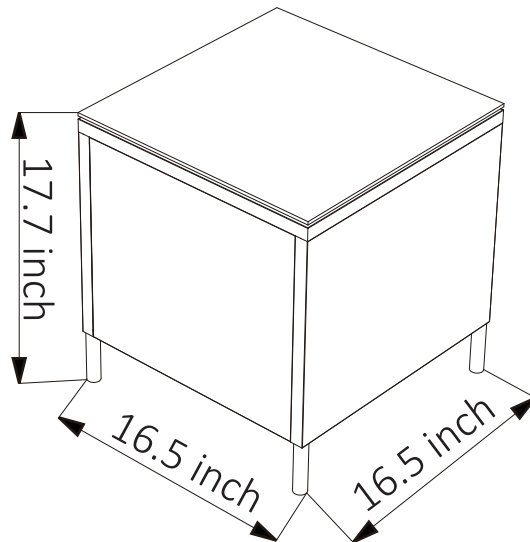
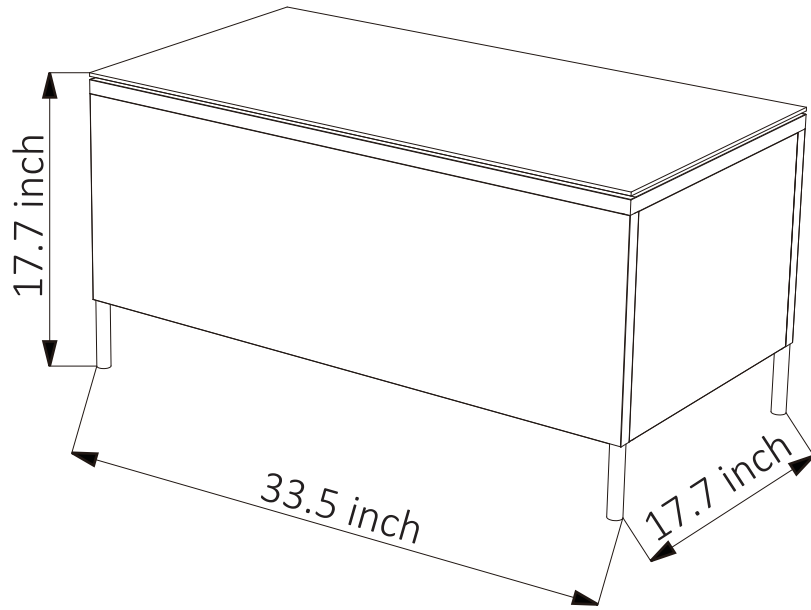

## Catalog

Specifications .....	01
Before you begin .....	04
Part List And Extra .....	05
How to Assemble The Single Sofa .....	12
How to Assemble The Three-person Sofa .....	16
How to Assemble The Footrests .....	24
How to Assemble The Square Coffee Table.....	26
How to Assemble The Long Coffee Table .....	28



# Before You Begin

**Assembly Instructions:**

Instructions are supplied in this manual and contain all appropriate information for your building model.

Review all instructions before you begin and during assembly, follow the step sequence carefully for correct results.

**Parts and Parts List:**

Check to be sure that you have all the necessary parts for building.

Separate contents of the carton by the part number while reviewing parts list.

Familiarize yourself with the hardware and fasteners for easier use during construction.











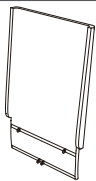
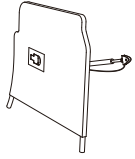
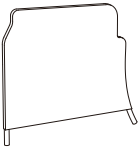
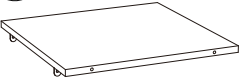
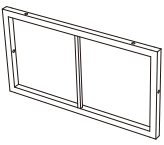

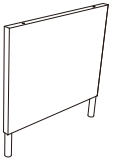
The first few steps show how to join related parts which is to obtain larger sub-assemblies be used later.

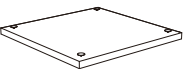
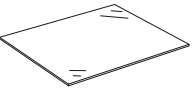
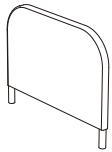
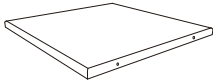
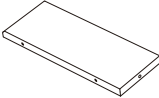
All parts are packaged within the carton.

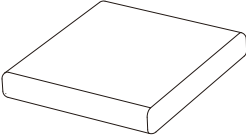
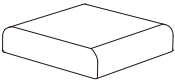
Note that extra fasteners have been supplied for your convenience.





# PART LIST

## Parts List (Box A)





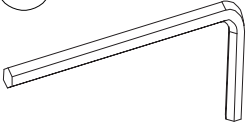
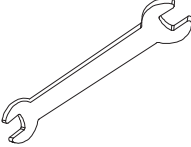

<p><b>A1</b></p>  <p>Single-seat Backplate</p>	<p><b>B1</b></p>  <p>Right Armrest With Air Bar</p>	<p><b>B2</b></p>  <p>Left Armrest</p>	<p><b>C1</b></p>  <p>Base Plate</p>	<p><b>D1</b></p>  <p>Front Panel</p>
1 PC	1 PC	1 PC	1 PC	1 PC
<p><b>E</b></p>  <p>Supporting Crossbar</p>	<p><b>F1</b></p>  <p>Square Coffee Table Legs</p>	<p><b>G1</b></p>  <p>Square Coffee Table Side Panel</p>	<p><b>H1</b></p>  <p>Square Coffee Table Tabletop</p>	<p><b>I1</b></p>  <p>Square Coffee Table Glass</p>
1 PC	2 PCS	2 PCS	1 PC	1 PC
<p><b>J</b></p>  <p>Footrest Legs</p>	<p><b>K</b></p>  <p>Footrest Base Board</p>	<p><b>L</b></p>  <p>Footrest Side Panel</p>	<p><b>O</b></p>  <p>Back Cushion</p>	<p><b>P1</b></p>  <p>Cushion</p>
2 PCS	1 PC	2 PCS	1 PC	1 PC
<p><b>P2</b></p>  <p>Footrest Cushion</p>				
1 PC				
<b>Screws Set A</b>				
<p><b>Q1</b></p>  <p>M6*15</p>	<p><b>Q2</b></p>  <p>M6*20</p>	<p><b>Q4</b></p>  <p>M6*35</p>	<p><b>Q6</b></p>  <p>M8*40</p>	<p><b>S1</b></p>  <p>M6 Nut</p>
4 PCS	2 PCS	32 PCS	2 PCS	2 PCS

# PART LIST

## Screws Set A



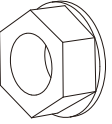

<p><b>S2</b></p>  <p>M8 Nut</p>	<p><b>T1</b></p>  <p>M6 Universal Wrench</p>	<p><b>T2</b></p>  <p>M8 Universal Wrench</p>	<p><b>U1</b></p>  <p>Wrench</p>	<p><b>R</b></p>  <p>Plastic Gasket</p>
2 PCS	1 PC	1 PC	1 PC	2 PCS

## Extra (Box A)



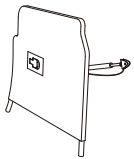
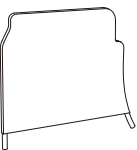
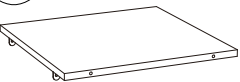
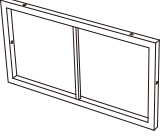

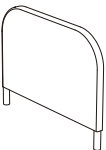
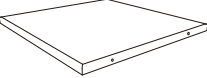
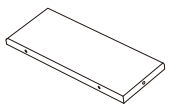
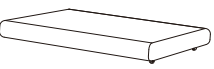
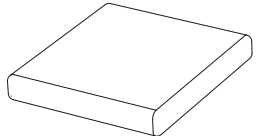



<p><b>Q1</b></p>  <p>M6*15</p>	<p><b>Q2</b></p>  <p>M6*20</p>	<p><b>Q4</b></p>  <p>M6*35</p>	<p><b>Q6</b></p>  <p>M8*40</p>	<p><b>S1</b></p>  <p>M6 Nut</p>
2 PCS	1 PC	2 PCS	1 PC	1 PC
<p><b>S2</b></p>  <p>M8 Nut</p>	<p><b>R</b></p>  <p>Plastic Gasket</p>			
1 PC	1 PC			

# PART LIST

## Parts List (Box B)

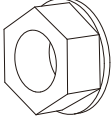

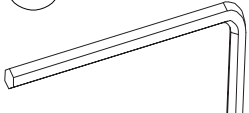
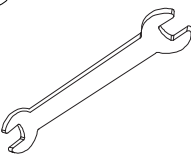



 <p><b>A1</b> Single-seat Backplate</p>	 <p><b>B1</b> Right Armrest With Air Bar</p>	 <p><b>B2</b> Left Armrest</p>	 <p><b>C1</b> Base Plate</p>	 <p><b>D1</b> Front Panel</p>
1 PC	1 PC	1 PC	1 PC	1 PC
 <p><b>E</b> Supporting Crossbar</p>	 <p><b>J</b> Footrest Legs</p>	 <p><b>K</b> Footrest Base Board</p>	 <p><b>L</b> Footrest Side Panel</p>	 <p><b>O</b> Back Cushion</p>
1 PC	2 PCS	1 PC	2 PCS	1 PC
 <p><b>P1</b> Cushion</p>	 <p><b>P2</b> Footrest Cushion</p>			
1 PC	1 PC			

## Screws Set B

 <p><b>Q1</b> M6*15</p>	 <p><b>Q2</b> M6*20</p>	 <p><b>Q4</b> M6*35</p>	 <p><b>Q6</b> M8*40</p>	 <p><b>S1</b> M6 Nut</p>
4 PCS	2 PCS	20 PCS	2 PCS	2 PCS
 <p><b>S2</b> M8 Nut</p>	 <p><b>T1</b> M6 Universal Wrench</p>	 <p><b>T2</b> M8 Universal Wrench</p>	 <p><b>U1</b> Wrench</p>	 <p><b>R</b> Plastic Gasket</p>
2 PCS	1 PC	1 PC	1 PC	2 PCS



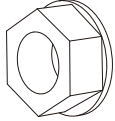







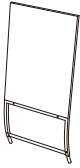

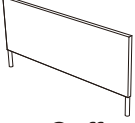
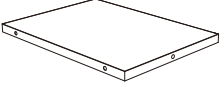
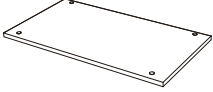

# PART LIST

## Extra (Box B)

Extra (Box B)				
<p>Q1</p>  <p>M6*15</p> <p>2 PCS</p>	<p>Q2</p>  <p>M6*20</p> <p>1 PC</p>	<p>Q4</p>  <p>M6*35</p> <p>2 PCS</p>	<p>Q6</p>  <p>M8*40</p> <p>1 PC</p>	<p>S1</p>  <p>M6 Nut</p> <p>1 PC</p>
<p>S2</p>  <p>M8 Nut</p> <p>1 PC</p>	<p>R</p>  <p>Plastic Gasket</p> <p>1 PC</p>			

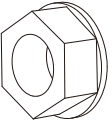

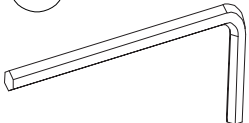
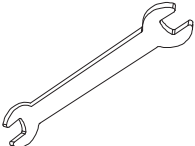





# PART LIST

## Parts List (Box C)

 <p><b>A2</b></p> <p>Middle back panel</p>	 <p><b>A3</b></p> <p>Right Back Panel</p>	 <p><b>A4</b></p> <p>Left Back Panel</p>	 <p><b>F2</b></p> <p>Long Coffee Table Legs</p>	 <p><b>G2</b></p> <p>Side Panel Of Long Coffee Table</p>
1 PC	1 PC	1PC	2 PCS	2 PCS
 <p><b>H2</b></p> <p>Long Coffee Table Tabletop</p>				
1 PC				
<b>Screws Set C</b>				
 <p><b>Q1</b></p> <p>M6*15</p>	 <p><b>Q2</b></p> <p>M6*20</p>	 <p><b>Q3</b></p> <p>M6*30</p>	 <p><b>Q4</b></p> <p>M6*35</p>	 <p><b>Q5</b></p> <p>M6*60</p>
8 PCS	4 PCS	10 PCS	26 PCS	6 PCS
 <p><b>Q6</b></p> <p>M8*40</p>	 <p><b>S1</b></p> <p>M6 Nut</p>	 <p><b>S2</b></p> <p>M8 Nut</p>	 <p><b>T1</b></p> <p>M6 Universal Wrench</p>	 <p><b>T2</b></p> <p>M8 Universal Wrench</p>
4 PCS	10 PCS	4 PCS	1 PC	1 PC
 <p><b>U1</b></p> <p>Wrench</p>	 <p><b>R</b></p> <p>Plastic Gasket</p>			
1 PC	4 PCS			



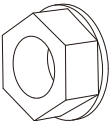



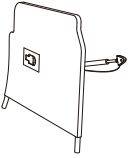

# PART LIST

## Extra (Box C)

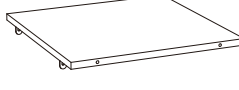
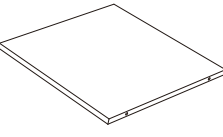
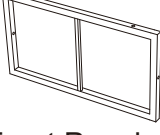
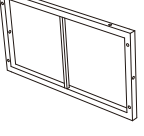
Extra (Box C)				
<p>Q1</p>  <p>M6*15</p> <p>2 PCS</p>	<p>Q2</p>  <p>M6*20</p> <p>2 PCS</p>	<p>Q3</p>  <p>M6*30</p> <p>2 PCS</p>	<p>Q4</p>  <p>M6*35</p> <p>2 PCS</p>	<p>Q5</p>  <p>M6*60</p> <p>1 PC</p>
<p>Q5</p>  <p>M8*40</p> <p>1 PC</p>	<p>S1</p>  <p>M6 Nut</p> <p>1 PC</p>	<p>S2</p>  <p>M8 Nut</p> <p>1 PC</p>	<p>R</p>  <p>Plastic Gasket</p> <p>1 PC</p>	

# PART LIST

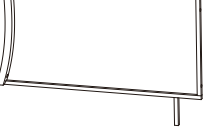
## Parts List (Box D)

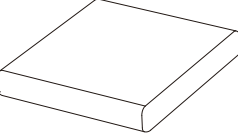
<p><b>B1</b></p>  <p>Right Armrest With Air Bar</p>	<p><b>B3</b></p>  <p>Left Armrest With Air Bar</p>	<p><b>C1</b></p>  <p>Base Plate</p>	<p><b>C2</b></p>  <p>Middle Base Plate</p>	<p><b>D1</b></p>  <p>Front Panel</p>
1 PC	1 PC	2 PCS	1 PC	2 PCS
<p><b>D2</b></p>  <p>Middle Front Panel</p>	<p><b>E</b></p>  <p>Supporting Crossbar</p>	<p><b>I2</b></p>  <p>Long Coffee Table Glass</p>	<p><b>M</b></p>  <p>Right Support Leg</p>	<p><b>N</b></p>  <p>Left Support Leg</p>
1 PC	2 PCS	1 PC	1 PC	1 PC
<p><b>O</b></p>  <p>Back Cushion</p>	<p><b>P1</b></p>  <p>Cushion</p>			
3 PCS	3 PCS			





# Installation steps

## How To Assemble Single Sofa

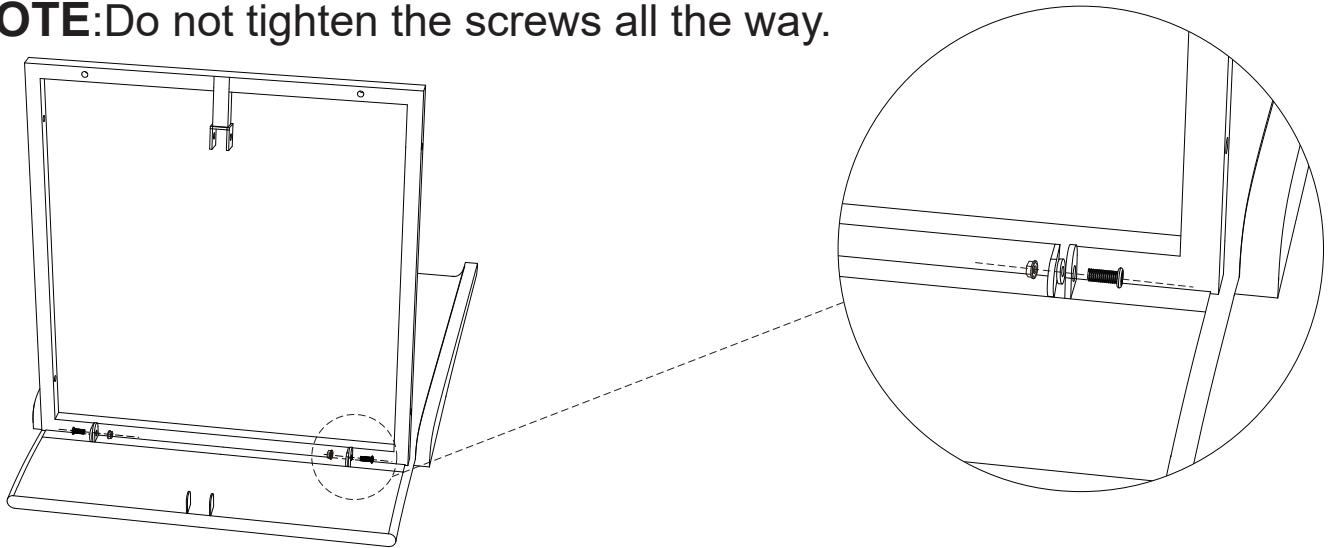
**Step 1:** Attach the base plate(C1) to the single seat back panel(A1).

**NOTE:** Do not tighten the screws all the way.



A1		x1	C1		x1	Q2		M6x20	x2
						S1			x2
						R			x2

**Step 2:** Attach the front plate(D1) to the base plate.

**NOTE:** Do not tighten the screws all the way.

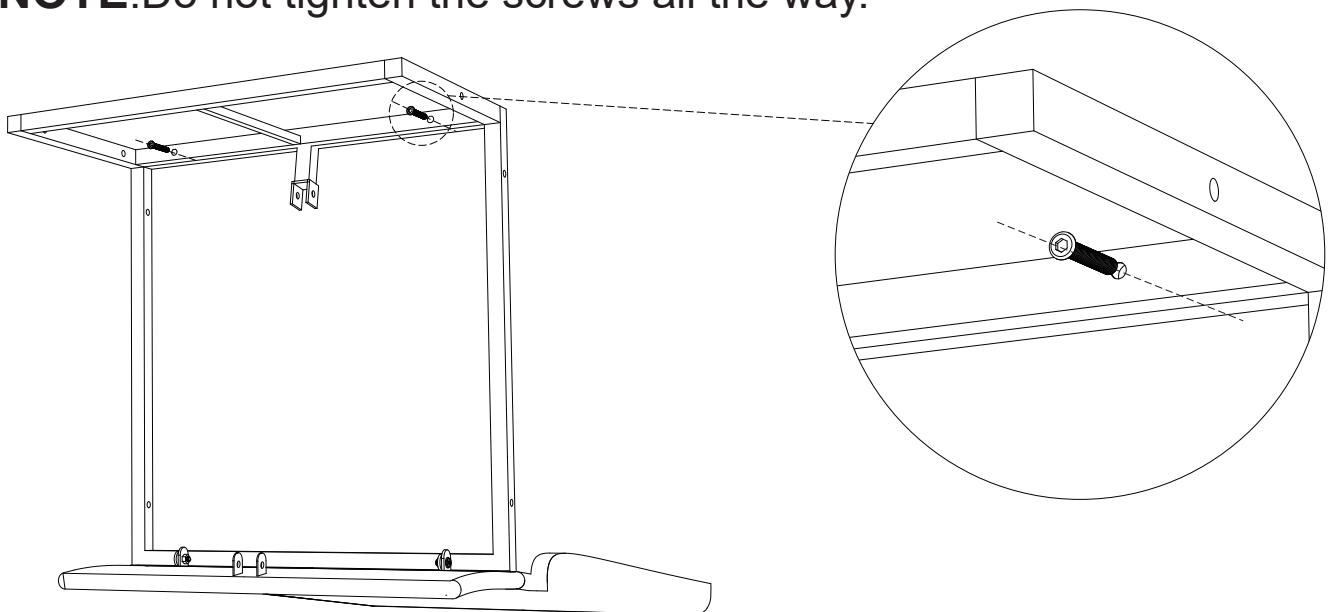

D1		x1	Q4		M6x35	x2
----	---	----	----	---	-------	----

## Installation steps

**Step 3:** Install the left armrest(B2) on the base plate.

**NOTE:** Do not tighten the screws all the way.

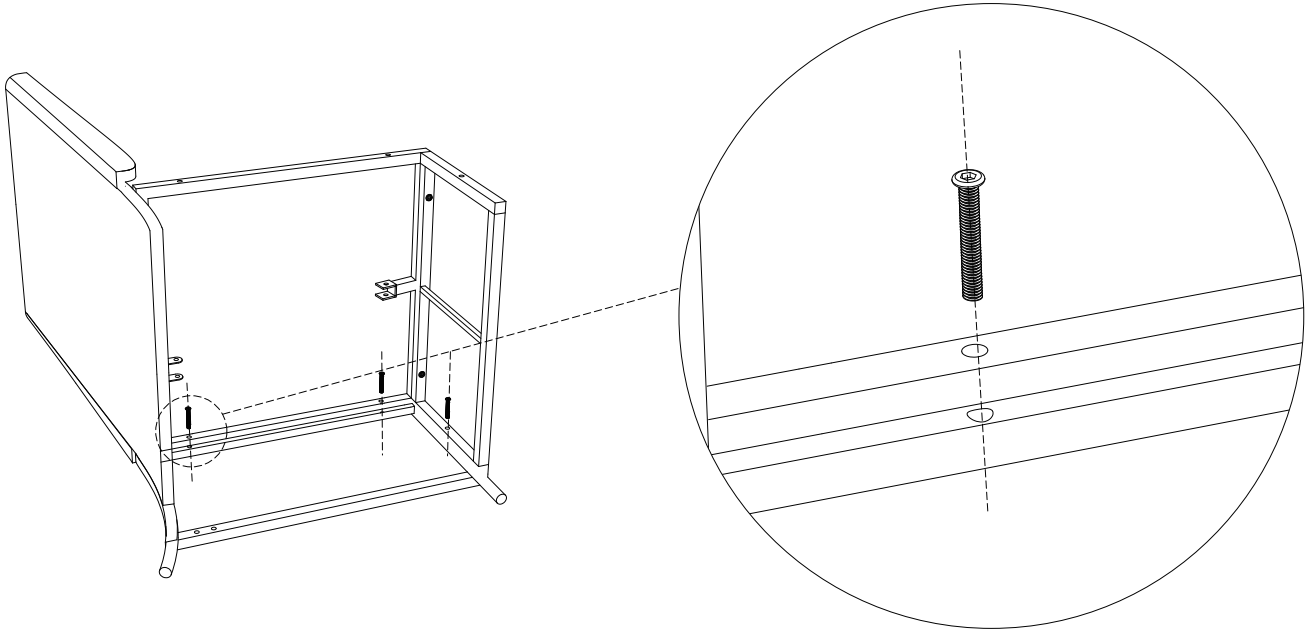

B2

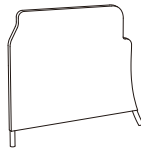

x1 Q4  M6x35 x3

**Step 4:** Install the right armrest(B1) on the base plate and attach the cylinder.

**NOTE:** Do not tighten the screws all the way.

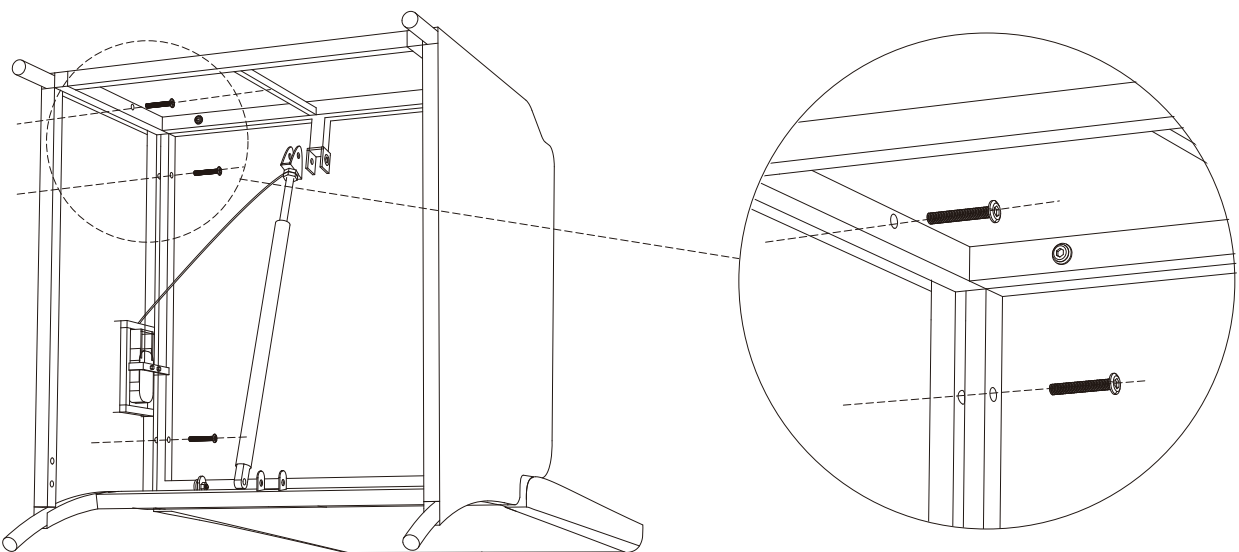

B1

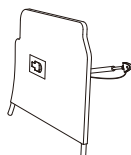



x1 Q4  M6x35 x3

# Installation steps

**Step 5:** Connect the cylinder to the seat with the cylinder line on the side away from the seat.

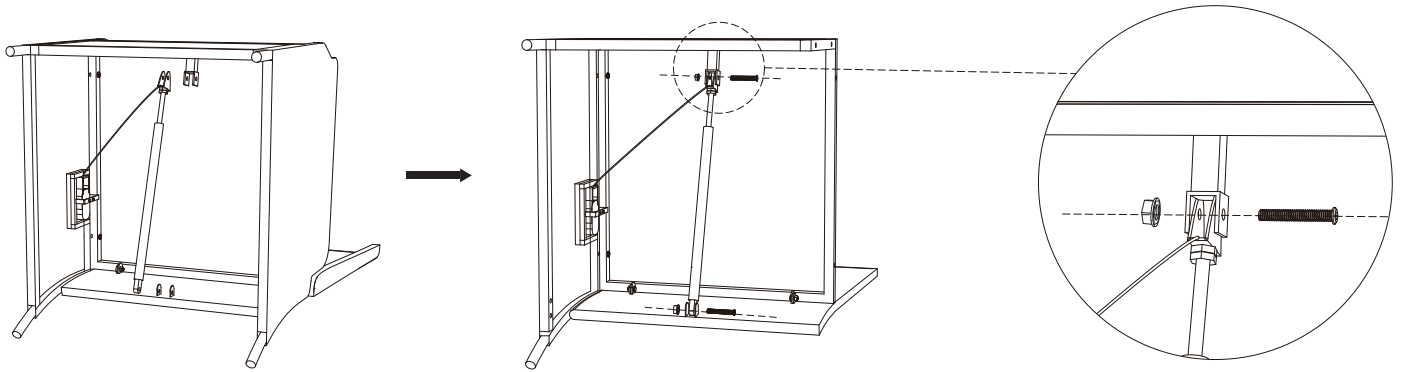
**NOTE:** Do not tighten the screws all the way.



Q6	 M8x40	x2	S2		x2
----	---	----	----	---	----

**Step 6:** Attach the support crossbar(E).

**NOTE:** Please tighten all screws.

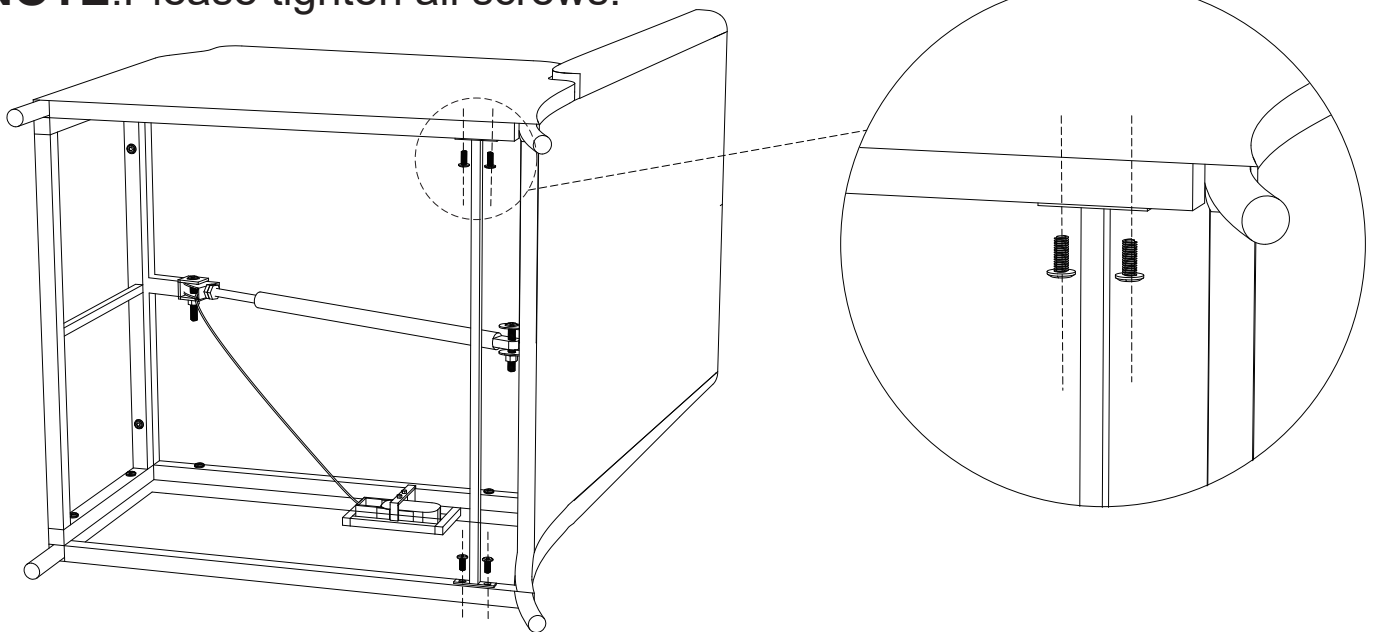

E		x1	Q1	 M6x15	x4
---	---	----	----	---	----

## Installation steps

**Step 7:** Place the cushion (P1) on the sofa. Attach the back cushions (O) to the sofa and tuck the olive buckle into the rattan.

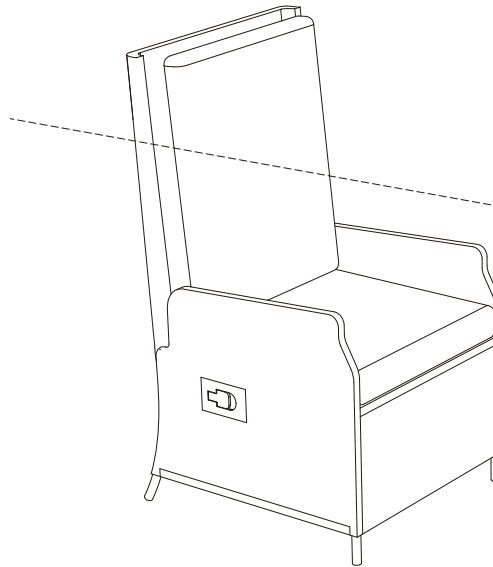
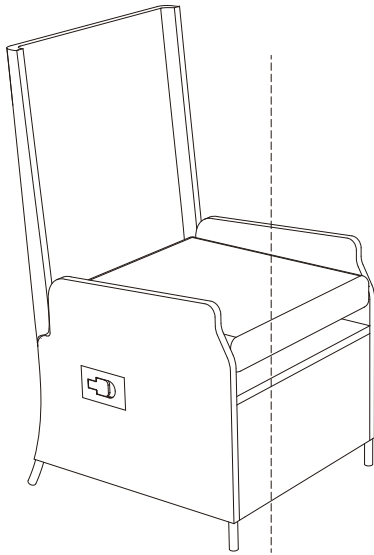

P1

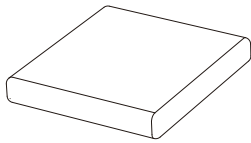

x1 O

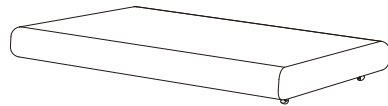

x1

**NOTE:** In order for the cylinder to function properly, the screws of the cylinder need to be locked.

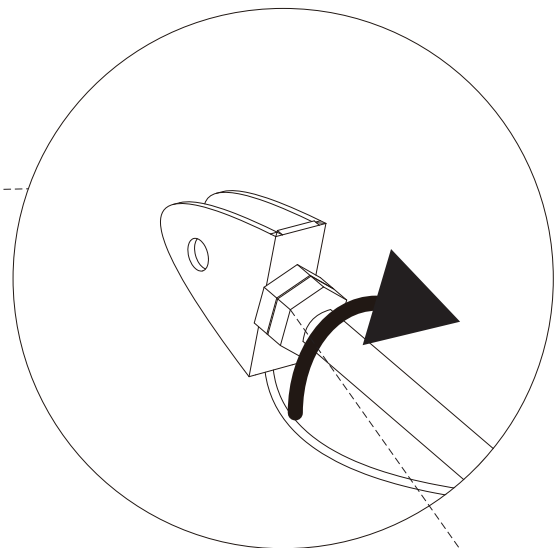
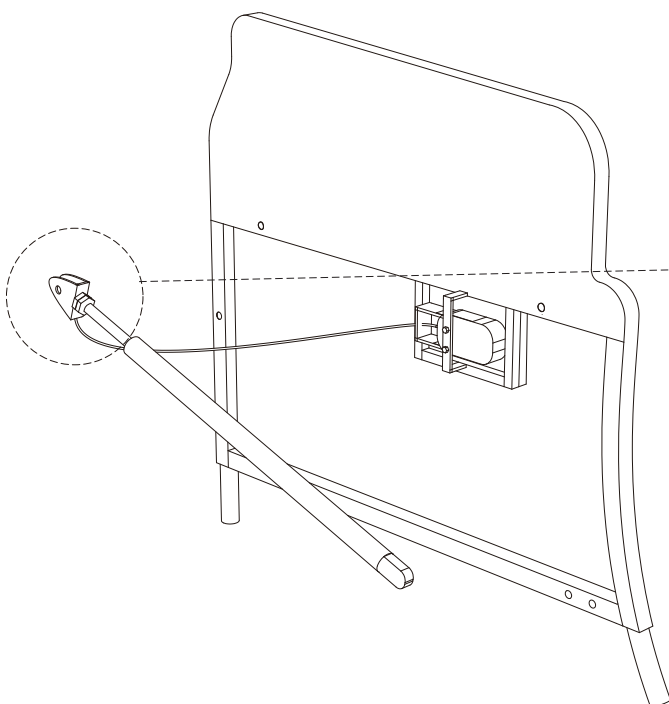

Tighten these two screws





# Installation steps

## How To Assemble Three-seat Sofa

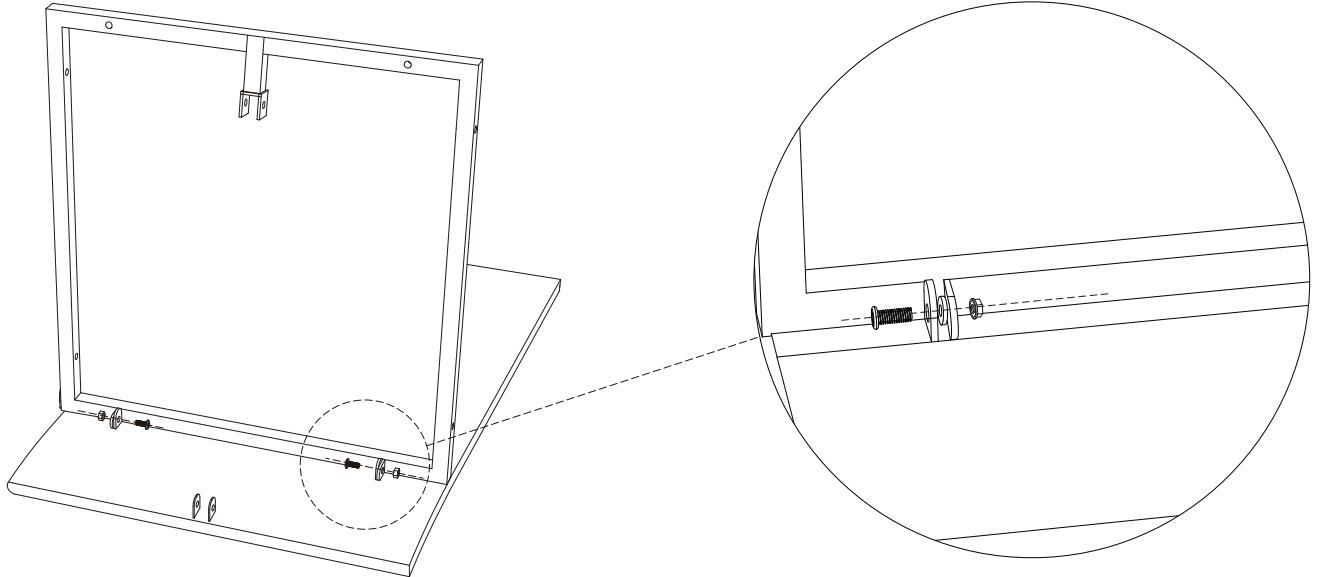
**Step 1:** Attach the base plate(C1) to the right back panel(A3).

**NOTE:** Do not tighten the screws all the way.





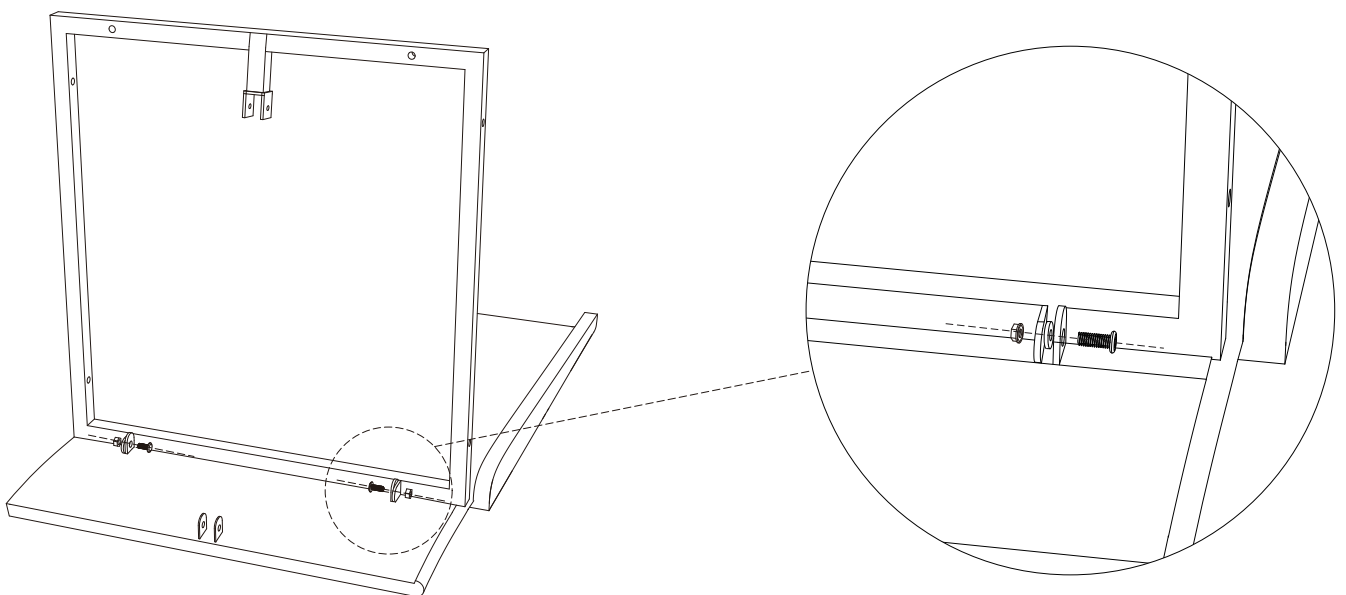

A3		x1	C1		x1	Q2		M6x20	x2
						S1			x2
						R			x2

**Step 2:** Attach the base plate(C1) to the left back panel(A4).

**NOTE:** Do not tighten the screws all the way.



A4		x1	C1		x1	Q2		M6x20	x2
						S1			x2
						R			x2

## Installation steps

**Step 3:** Attach the middle base plate (C2) to the middle back panel (A2).  
**NOTE:** Do not tighten the screws all the way.

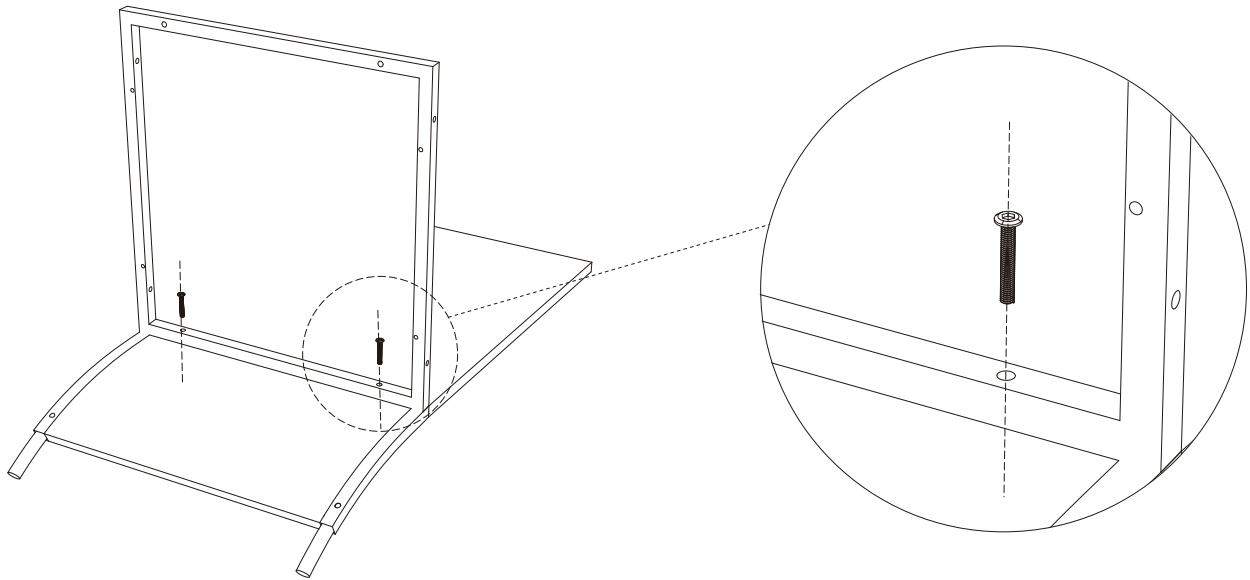

A2

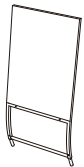

x1 C2

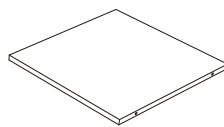

x1 Q4  M6x35 x2

**Step 4:** Attach the front plate (D1) to the right sofa.  
**NOTE:** Do not tighten the screws all the way.

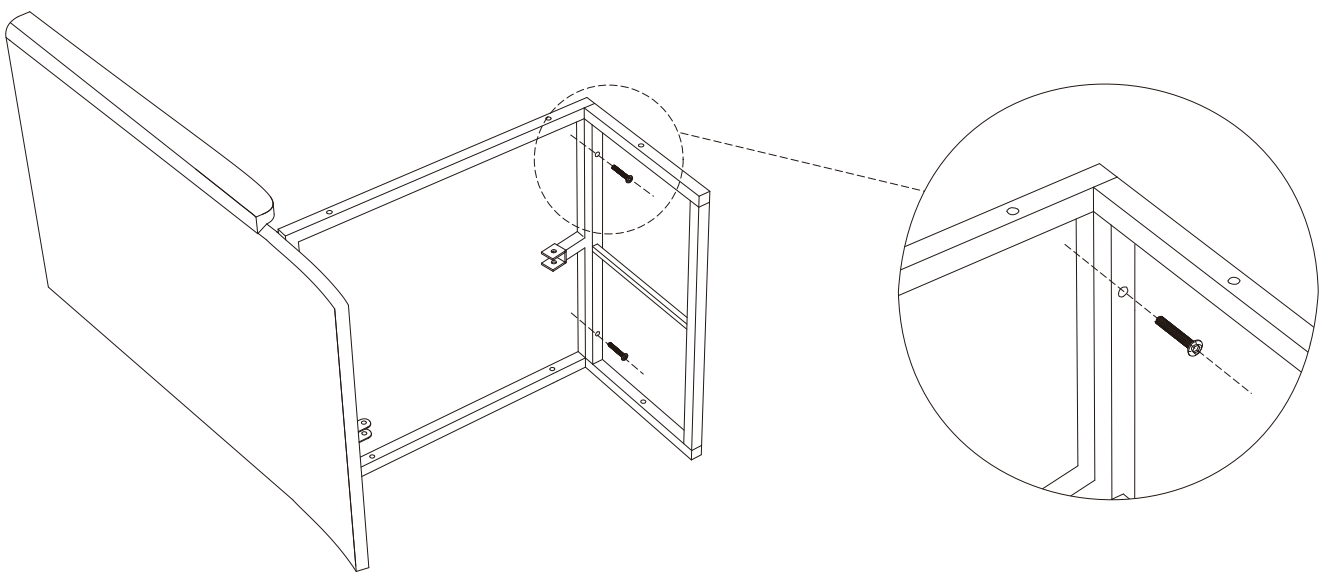

D1

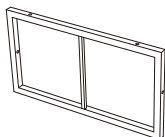

x1 Q4  M6x35 x2

# Installation steps

**Step 5:** Attach the middle front plate(D2)to the middle sofa.  
**NOTE:**Do not tighten the screws all the way.

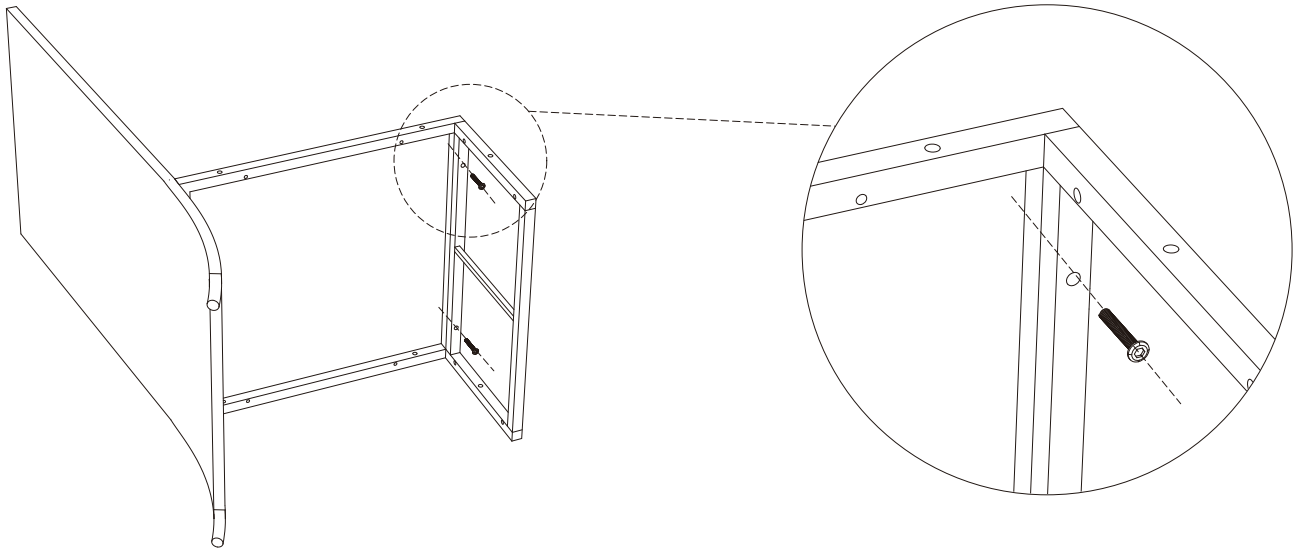

D2

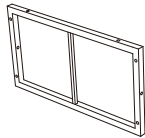

x1 Q4  M6x35 X2

**Step 6:** Attach the front plate(D1)to the left sofa.  
**NOTE:**Do not tighten the screws all the way.

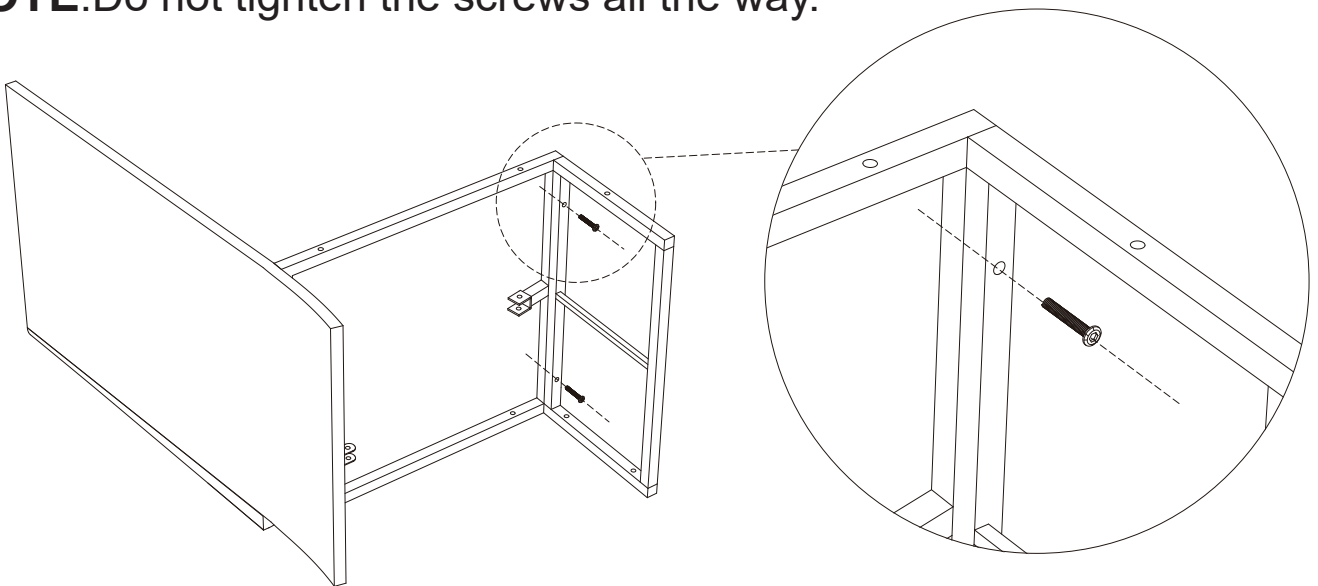

D1

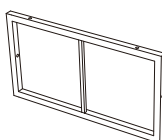

x1 Q4  M6x35 X2

# Installation steps

**Step 7:** Install the right armrest(B1) on the right sofa.

**NOTE:** Do not tighten the screws all the way.

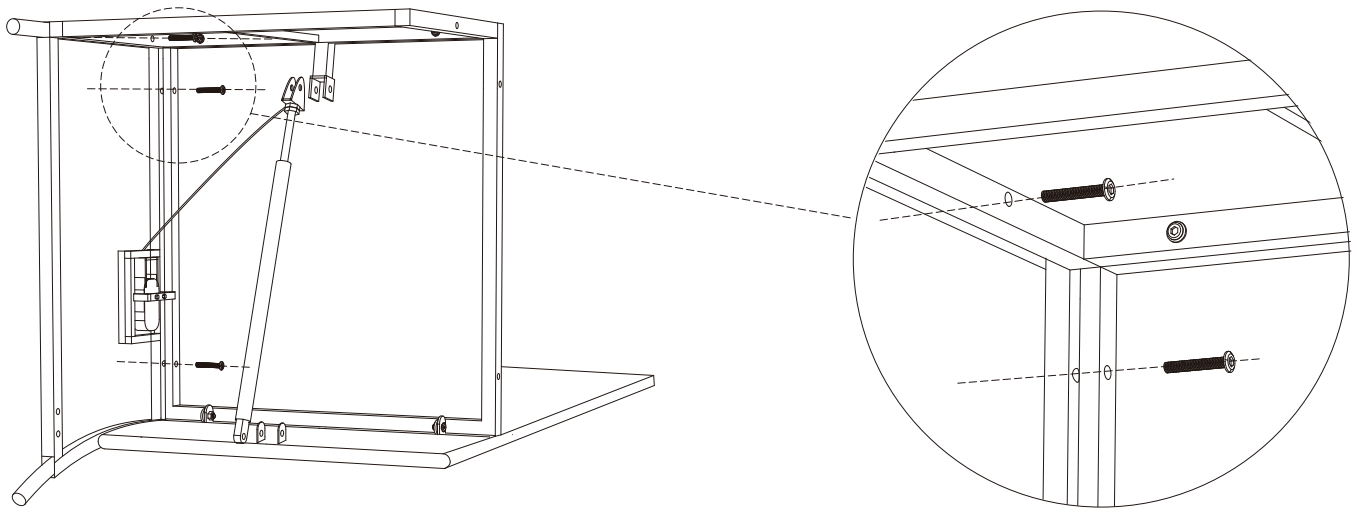

B1

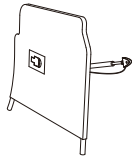

x1 Q4  M6x35 x3

**Step 8:** Connect the cylinder to the seat with the cylinder line on the side away from the seat.

**NOTE:** Do not tighten the screws all the way.

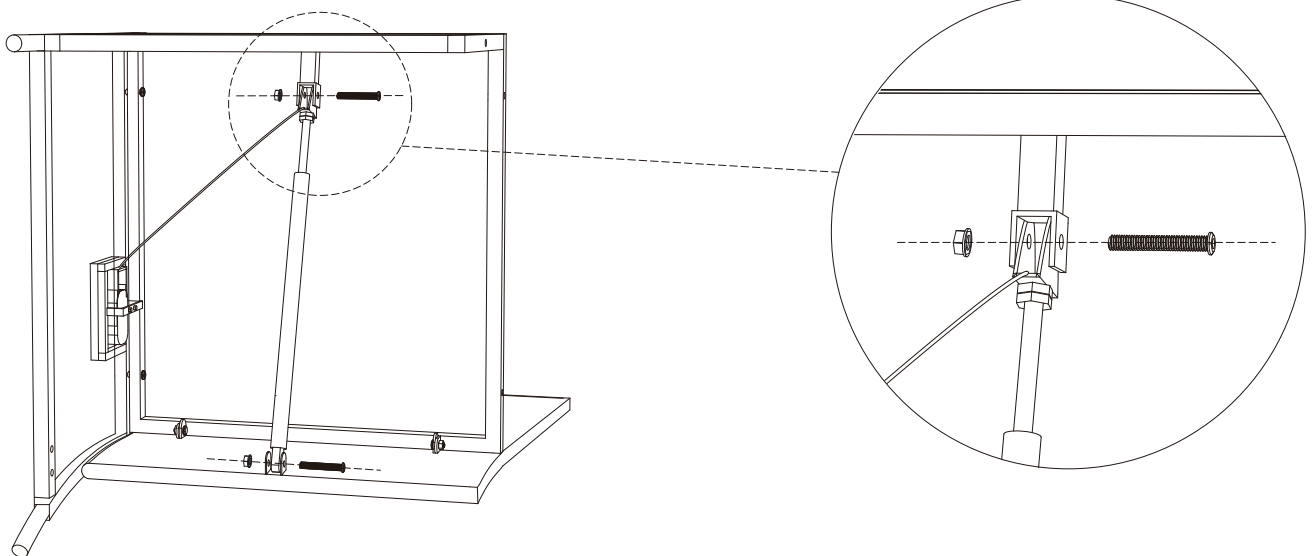

Q6

 M8x40

x2 S2



x2

# Installation steps

**Step 9:** Install the left armrest(B3) on the left sofa.

**NOTE:** Do not tighten the screws all the way.

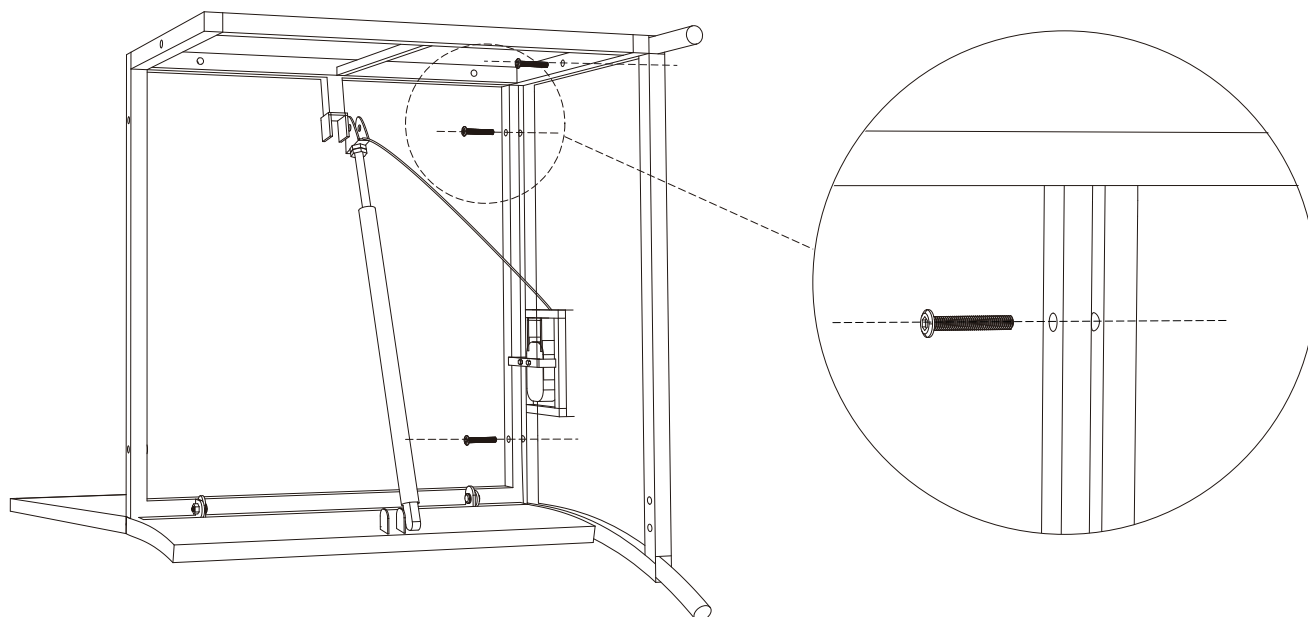

B3

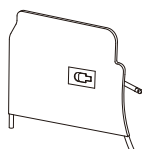

x1 Q4  M6x35 x3

**Step 10:** Connect the cylinder to the seat with the cylinder line on the side away from the seat.

**NOTE:** Do not tighten the screws all the way.

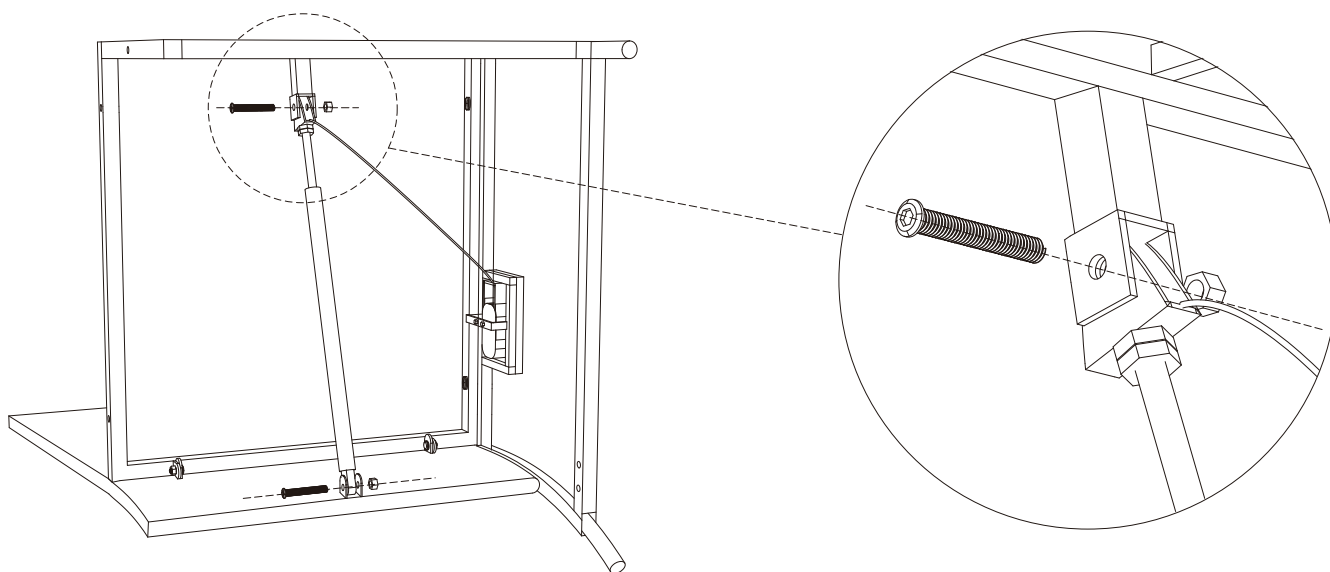

Q6

 M8x40

x2 S2





x2

# Installation steps

**Step 11:** Assemble the three sofas.

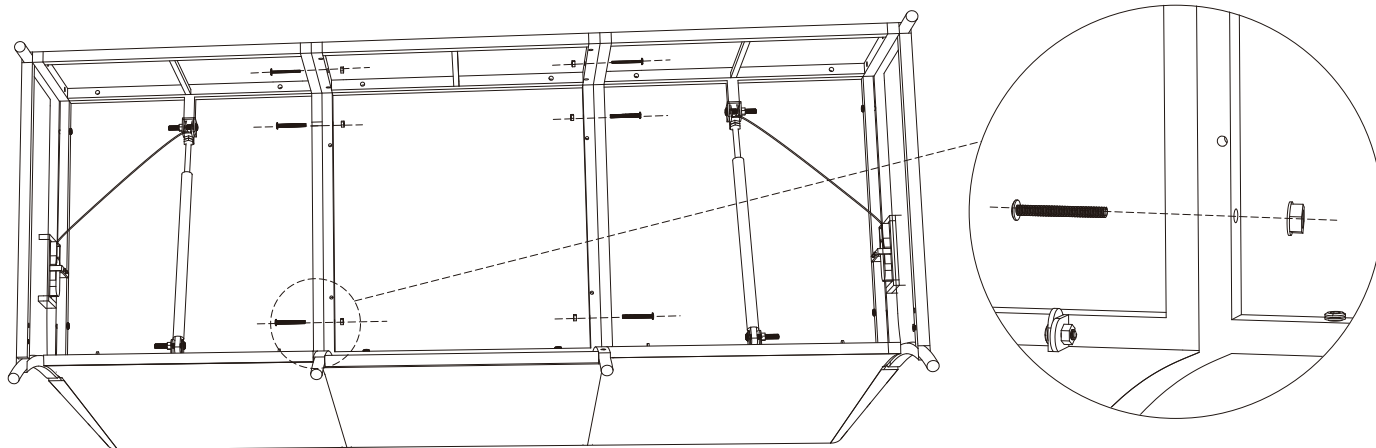
**NOTE:** Do not tighten the screws all the way.





Q5		M6x60	x6	S1		x6
----	---	-------	----	----	---	----

**Step 12:** Attach the left and right support legs(M,N)

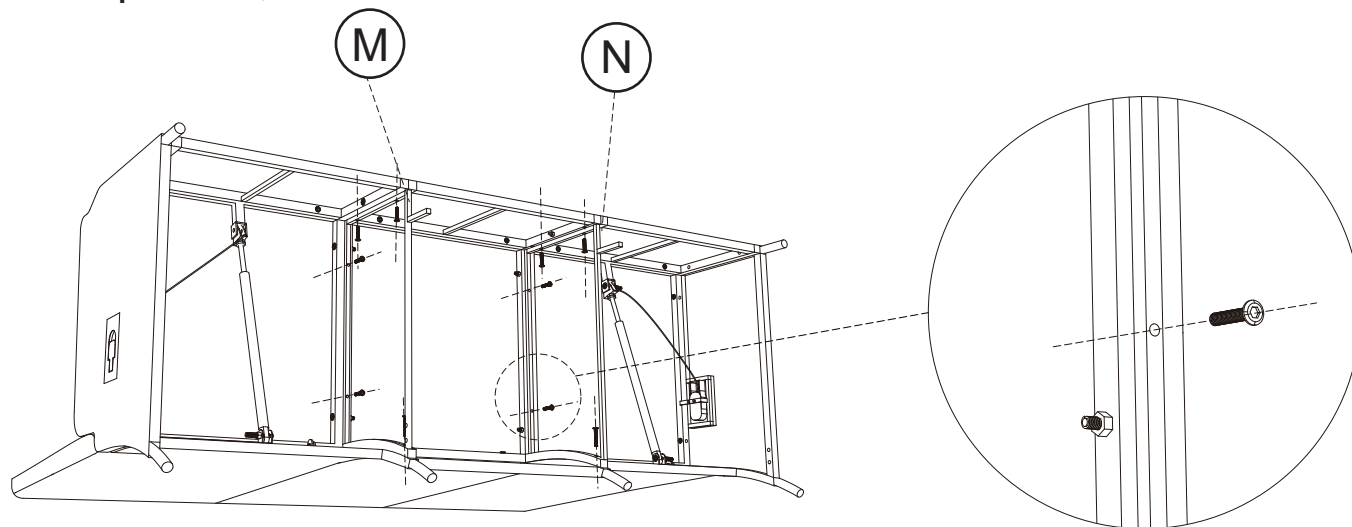
**NOTE:** Do not tighten the screws all the way. (M should be placed on the right and N should be placed on the left, and the position should not be misplaced.)

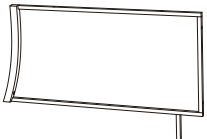

M		x1	N		x1	Q3		M6x30	x10
---	---	----	---	---	----	----	---	-------	-----

# Installation steps

**Step 13:** Fix the Supporting Crossbar(E) under the seat.

**NOTE:** Please tighten all screws.

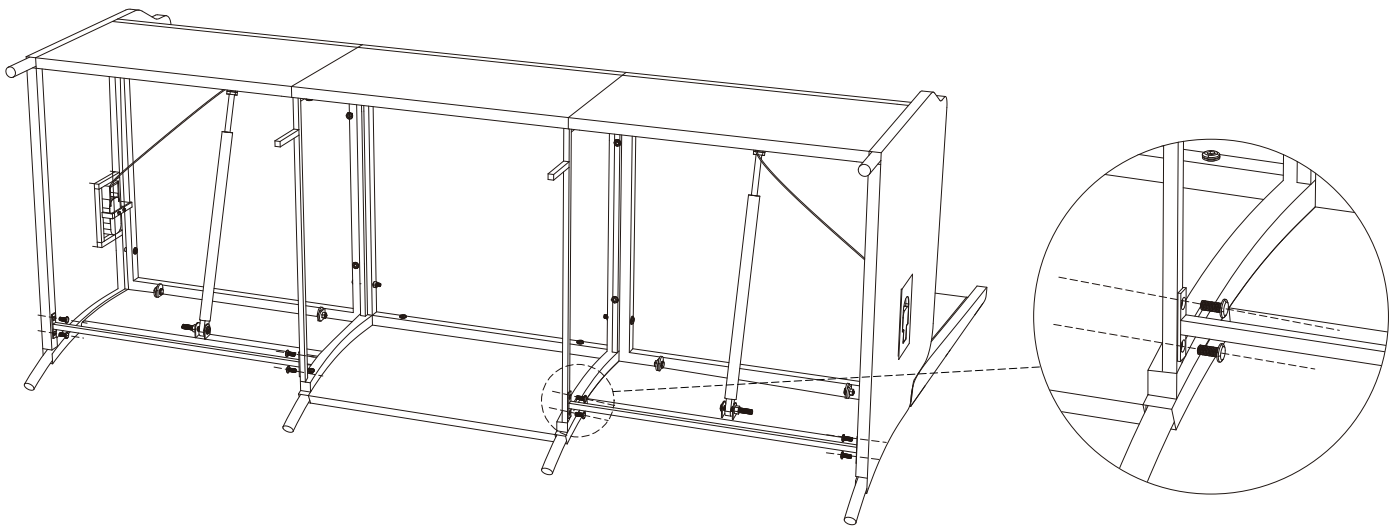

E

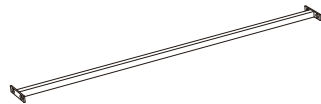

x2 Q1  M6x15 X8

**Step 14:** Place the cushion(P1) on. Attach the back cushions(O) to the sofa and tuck the olive buckle into the rattan.

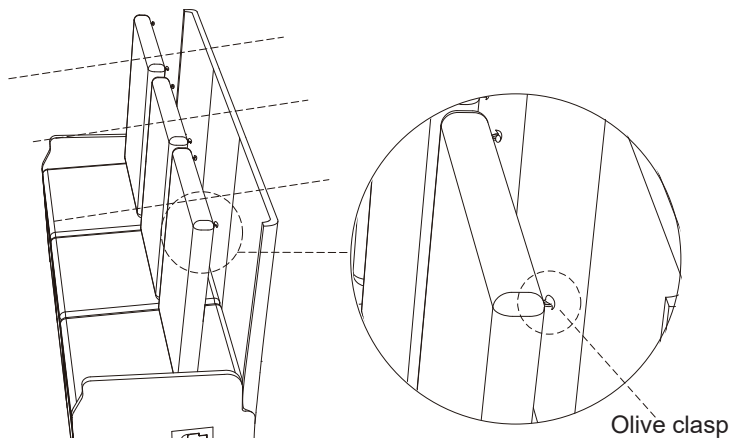
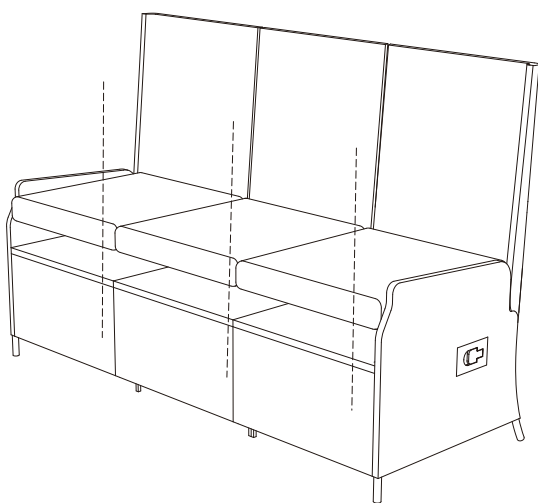

P1

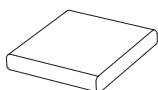

x3 O



x3

## Installation steps

**INSTRUCTIONS FOR USE:** Pull the adjuster with the hands and push your back back firmly to lie down.

**NOTE:** The three-seater sofa has only two sides, which wear the top hats.

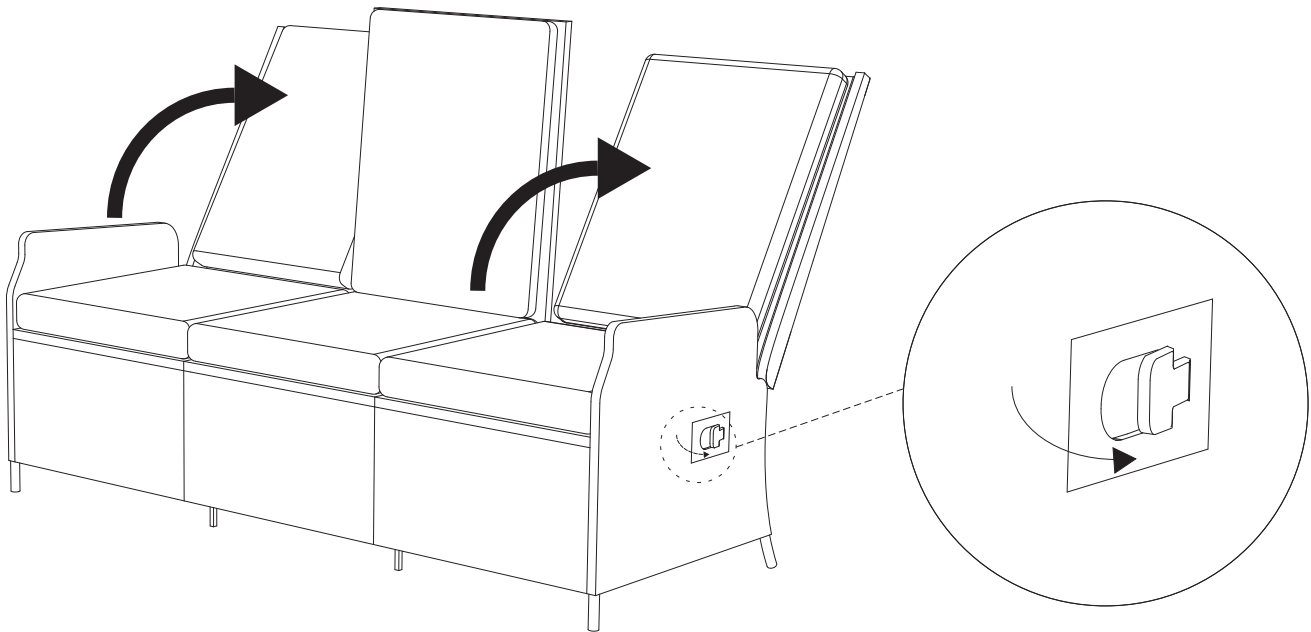

## How To Assemble Footrests

**Step 1:** Connect the footrest legs (J) to the footrest base plate (K).

**NOTE:** Do not tighten the screws all the way.

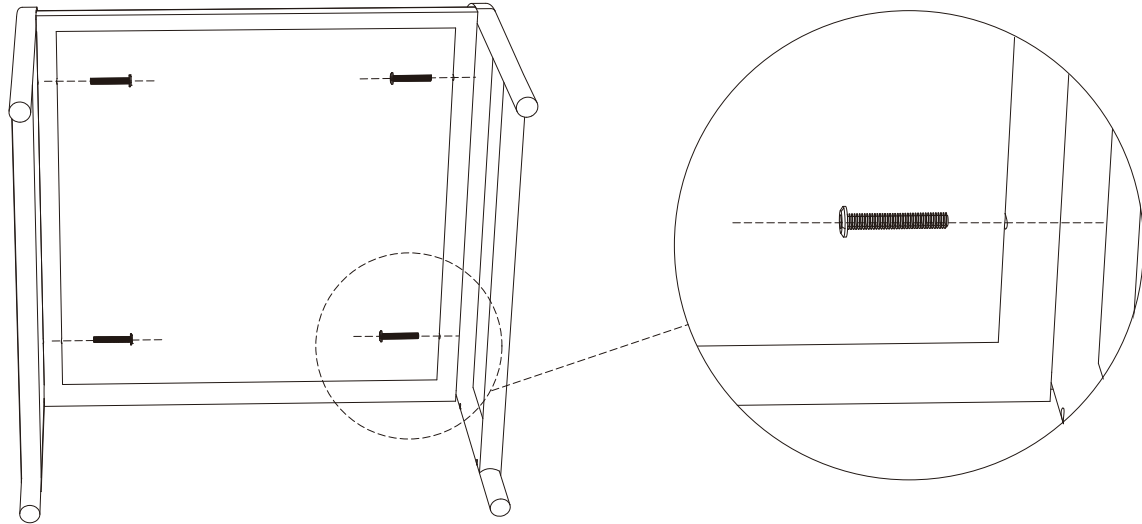

J

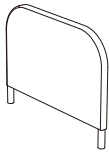

x2 K

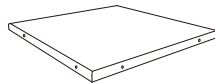

x1 Q4



M6x35

x4

**Step 2:** Attach the side panels (L) to the footrest.

**NOTE:** Please tighten all screws.

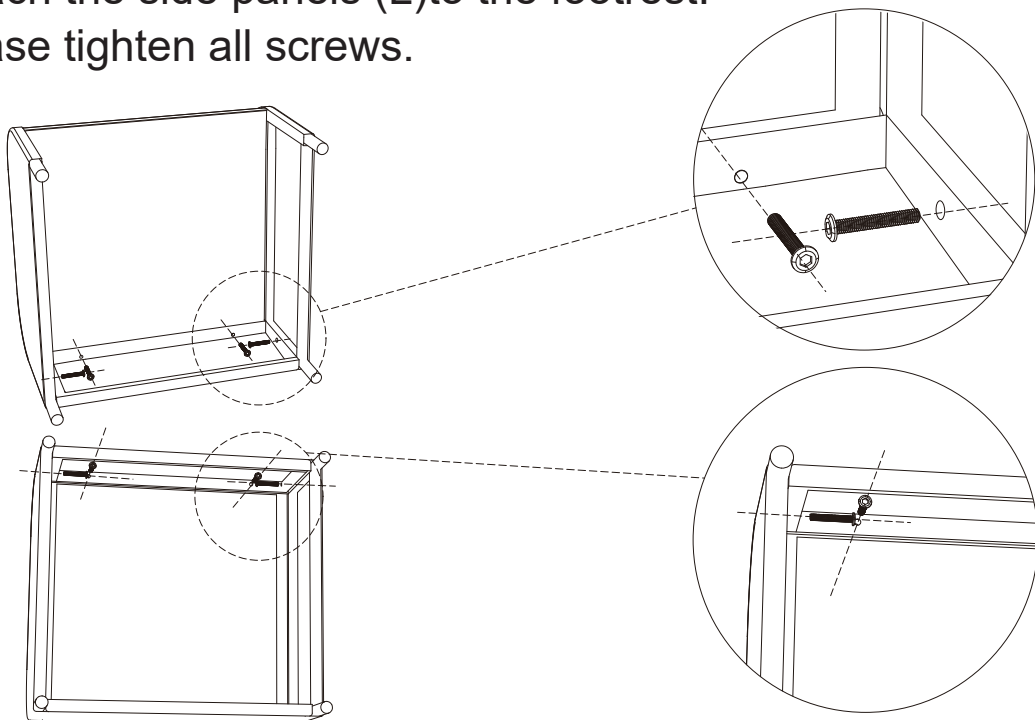

L

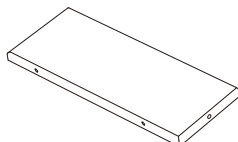

x2 Q4



M6x35

x8

## Installation steps

**Step 3:** Place the cushion(P2) on top.

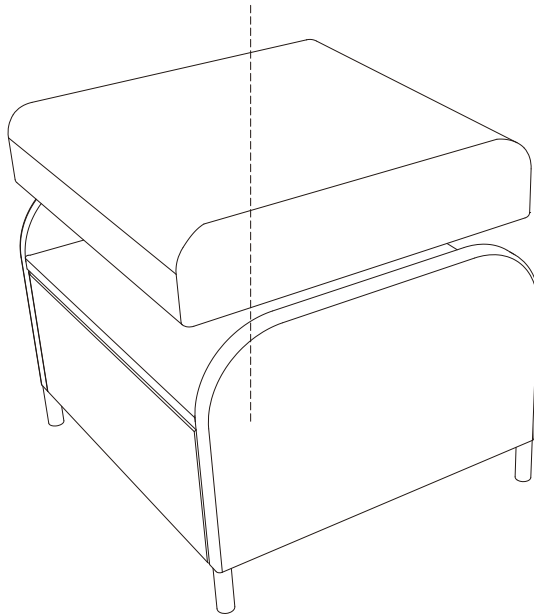

P2



x1

# Installation steps

## How To Assemble The Square Coffee Table

**Step 1:** Connect the square coffee table table top(H1)with the square coffee table legs(F1).

**NOTE:**Do not tighten the screws all the way.

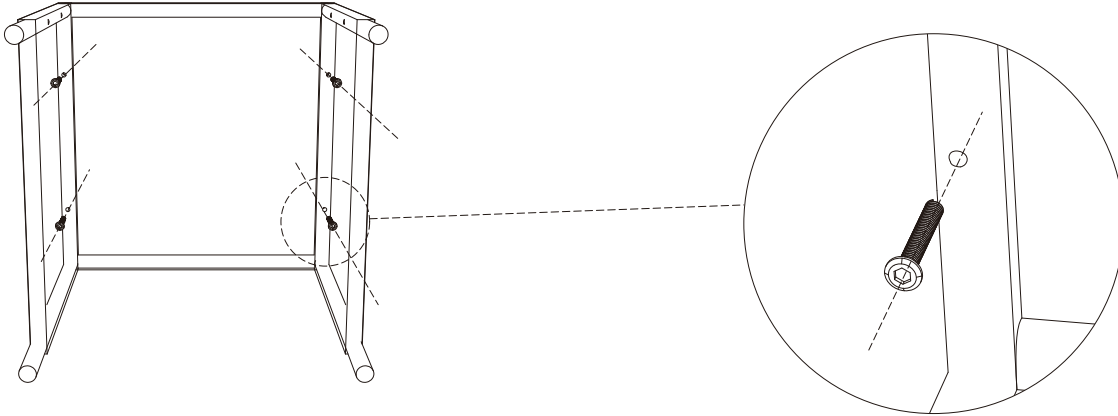

H1

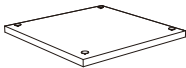

x1 F1

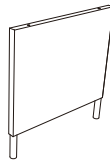

x2 Q4



M6x35

x4

**Step 2:** Install square coffee table side panel(G1).

**NOTE:**Please tighten all screws.

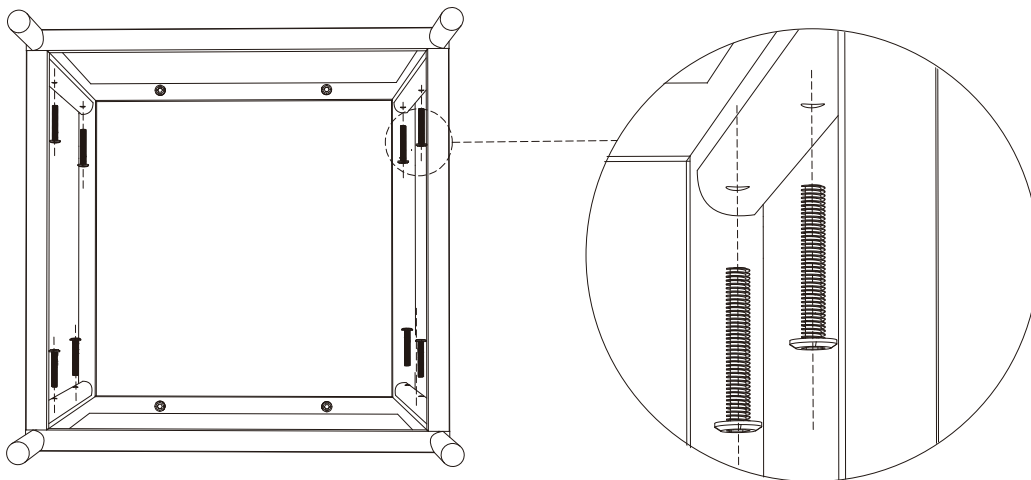

G1



x2 Q4



M6x35

x8

## Installation steps

**Step 3:** Place the square coffee table glass(I1).

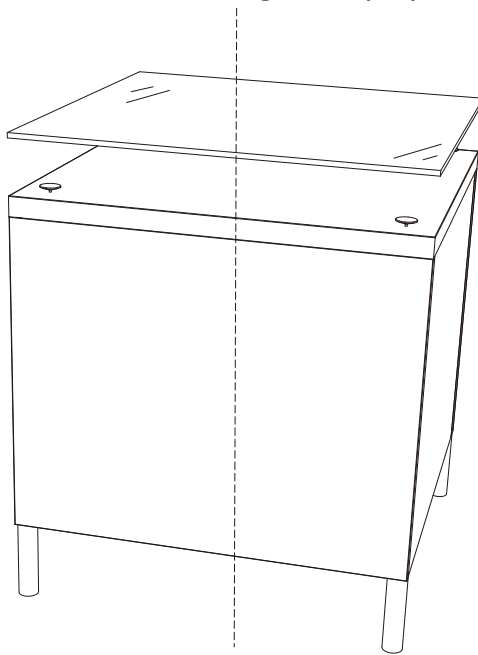

I1

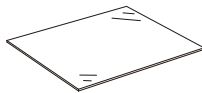

x1

# Installation steps

## How To Assemble The Long Coffee Table

**Step 1:** Connect the long coffee table tabletop(H2) to the long coffee table legs(F2).

**NOTE:** Do not tighten the screws all the way.

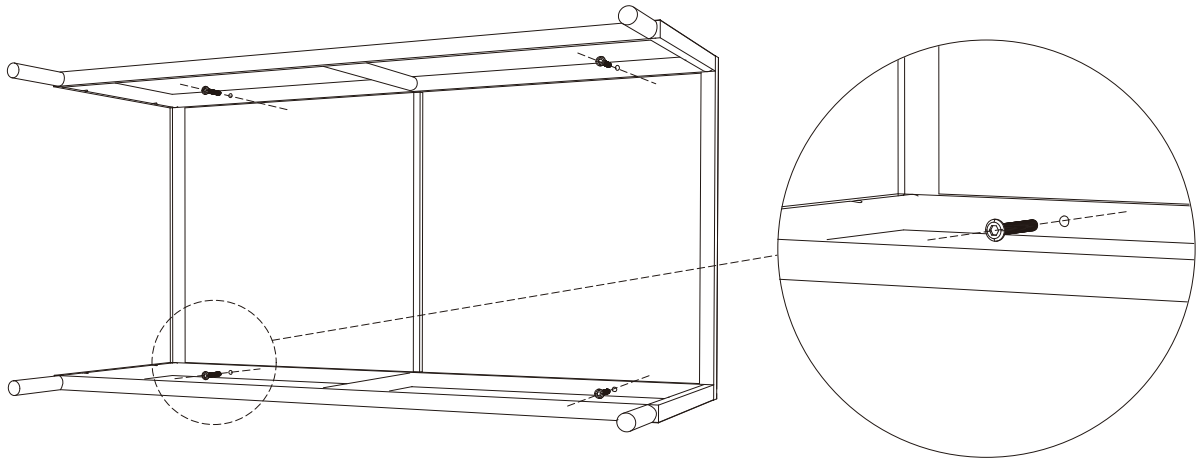

H2

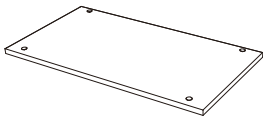

x1 F2

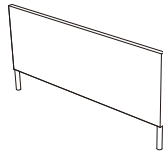

x2 Q4



M6x35

x4

**Step 2:** Install the long coffee table side panel(G2).

**NOTE:** Please tighten all screws.

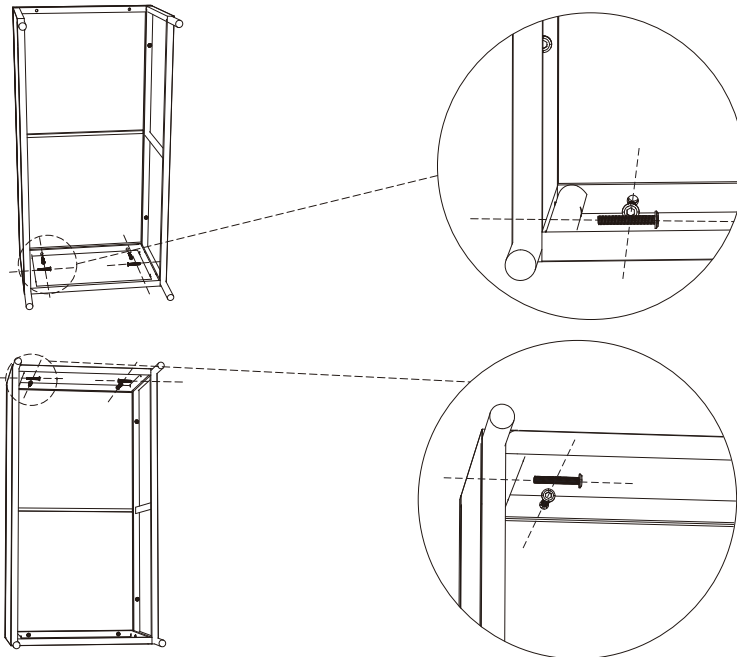

G2

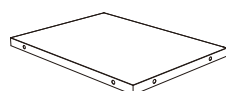

x2 Q4



M6x35

x8

## Installation steps

**Step 3:** Place the long coffee table glass(I2).

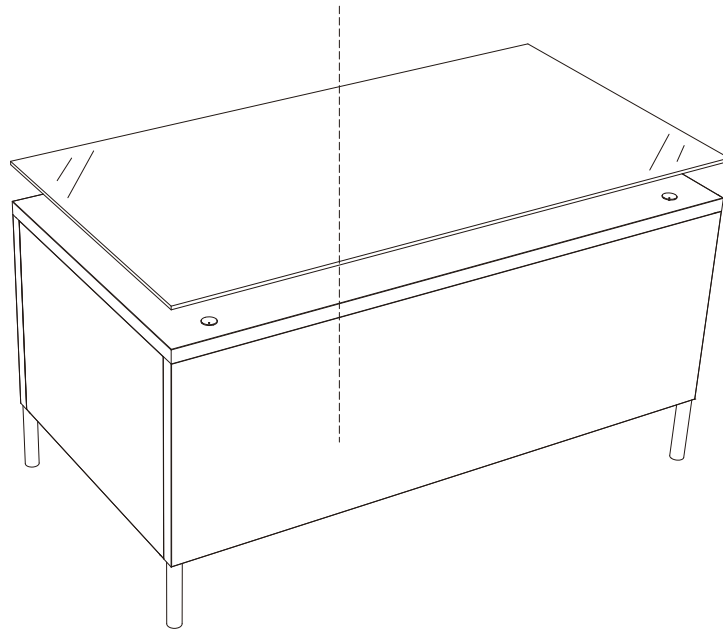

I2

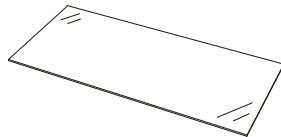

x1



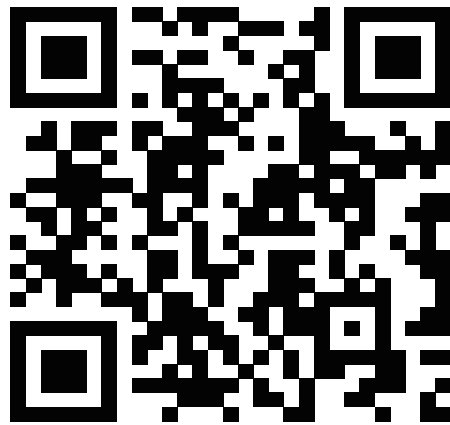

[www.alaulm.com](http://www.alaulm.com)

Make your life much better.