

Owner Manual

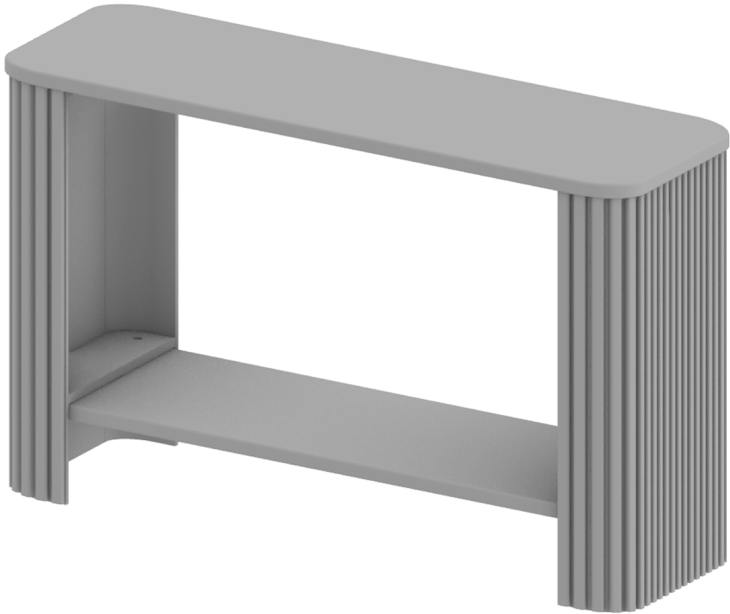

10 : 00

estimated assembly



2 or more

people required

Ok, let's
get started!



- Put on mood music!
- To prevent damage to product, use the clean side of package carton or rug as working surface.
- In the event of missing or damaged parts, delivery problems etc., please reach out to our team.
We will be happy to fix the problem!

care guide

- Clean regularly with a soft and dry cloth.
- To protect finish, avoid use of abrasive cleaners.
- Wipe up spills immediately. Please!



product parts



(A)
Table Top

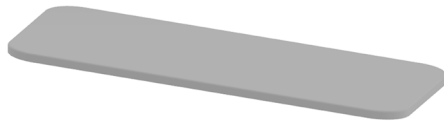

(B)
Shelve

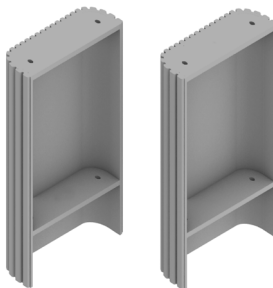

(C1,C2)
Table legs
x2

what's included



(D)- Plain Washer
(8x20mm)
x8



(E)- Lock Washer
(8x16mm)
x8



(F)- L Key Bolt
(8x25mm)
x8

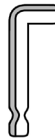

(G)- Allen Key
(5mm)
x1

OS

Orange sticker

GS

Green sticker

assembly instructions

Friendly Tip: Take a deep breath going in. This may be a tricky part, but nothing too overwhelming. Just follow these steps to the T and the outcome will be worth it!



- ⓘ While assembling the product, tighten the bolts up to 50%. Once all parts are in place, only then fully tighten the bolts.

step 1:

Start by placing the table top (A) sideways on a flat surface with the green sticker (GS) on the left side. Place the leg (C1) with the green sticker (GS) parallel to the table top.

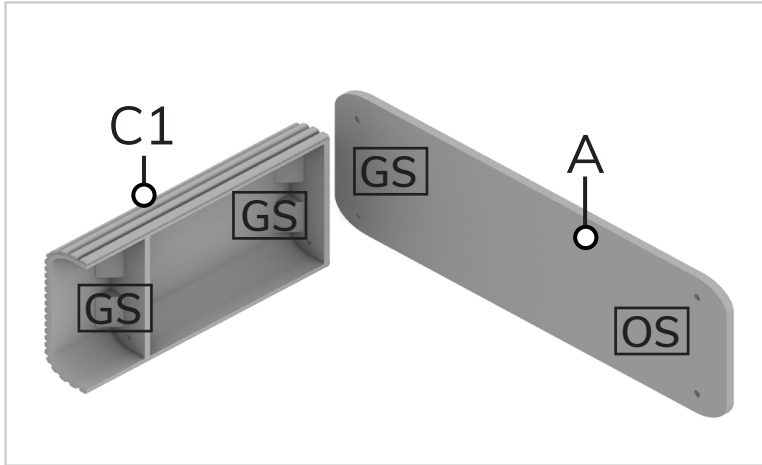

step 2:

Now align the slots on the table top (A) with the slots given on the leg (C1) top. Fix it in place by inserting washer (D), lock washer (E), and bolts (F) in the given slots. Tighten all the bolts up to 50% using allen key (G). Use the image below as reference.

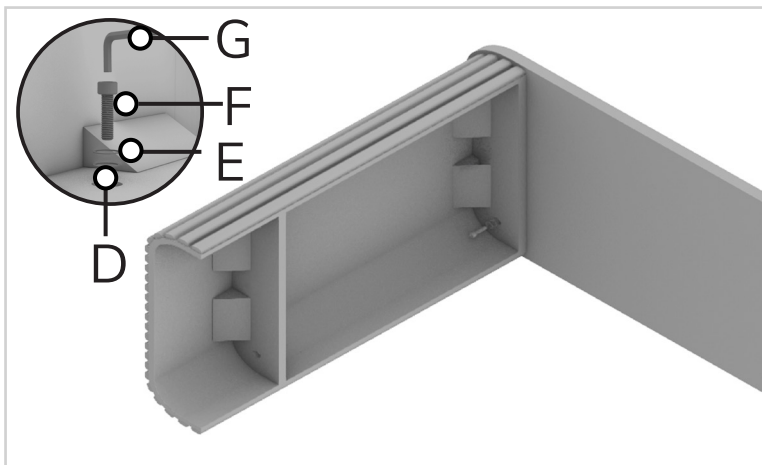

step 3:

Similarly, place the shelf (B) sideways and align the holes on the shelf (B) to the slots on the table leg (C1). Fix them in place by inserting washer (D), lock washer (E), and bolts (F) in the given slots. Tighten all the bolts up to 50% using allen key (G).

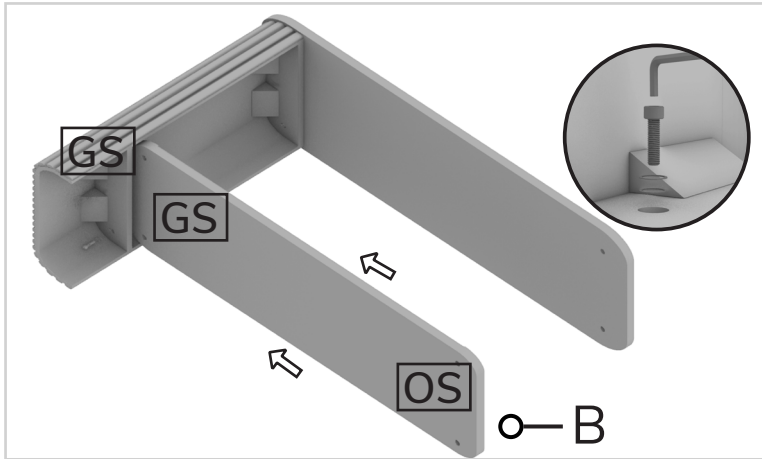

step 4:

When done, insert the leg (C2) on the right side of the table. Ensure the slots on the leg are aligned with the slots on the table top (A) & shelf (B). Fix it in place by inserting washer (D), lock washer (E), and bolts (F) in the given slots. Tighten all the bolts fully using allen key (G).

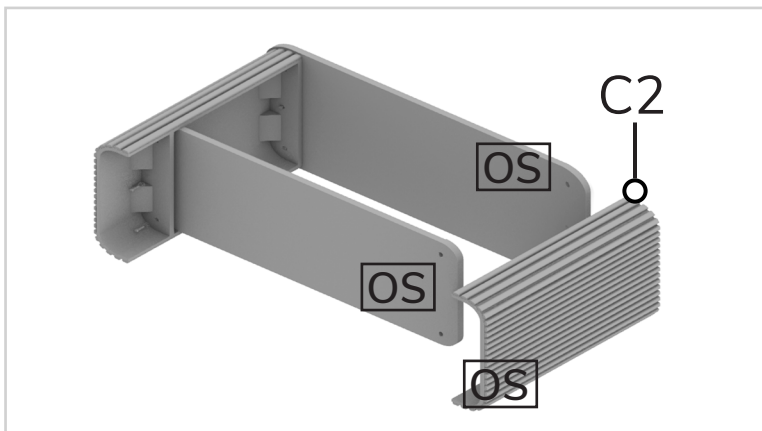

step 5:

Turn the table upright, as shown in the image.

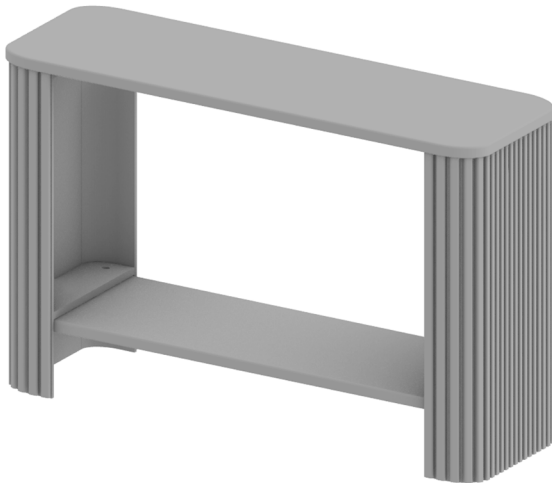
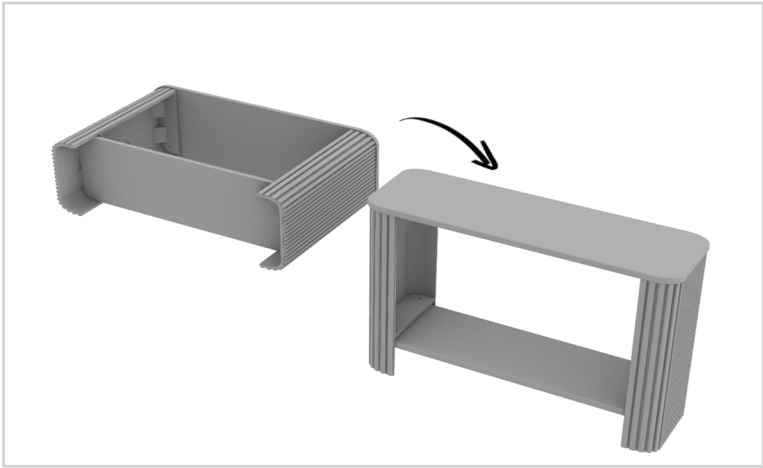

Your console table is now assembled and secure!