

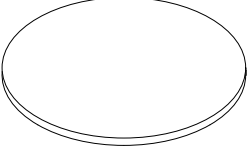

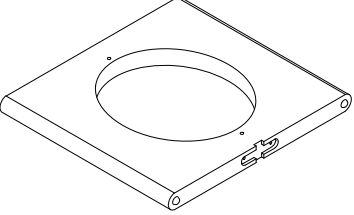

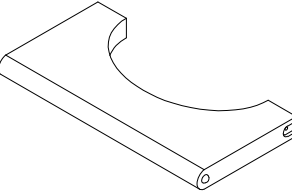

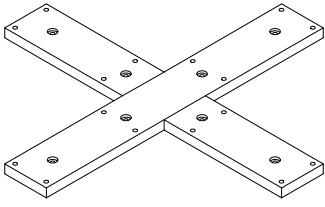

CVFVRD333-ASSEMBLY INSTRUCTIONS

PARTS LIST

No	Hardware List		Q'ty	A	B	C	D
1		Bolt 5/16"x40mm	28				
2		Lock washer 5/16"	28				
3		Flat washer 5/16"x19*2mm	28				
4		Allen key 4mm	1				
5		Metal Plate 150*150*2mm	1				

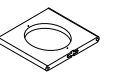
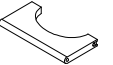
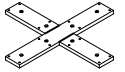
No	Parst List		Q'ty
A		Table Top	1
B		Leg B	1
C		Leg C	2
D		Mounting Plate	1

Step 1

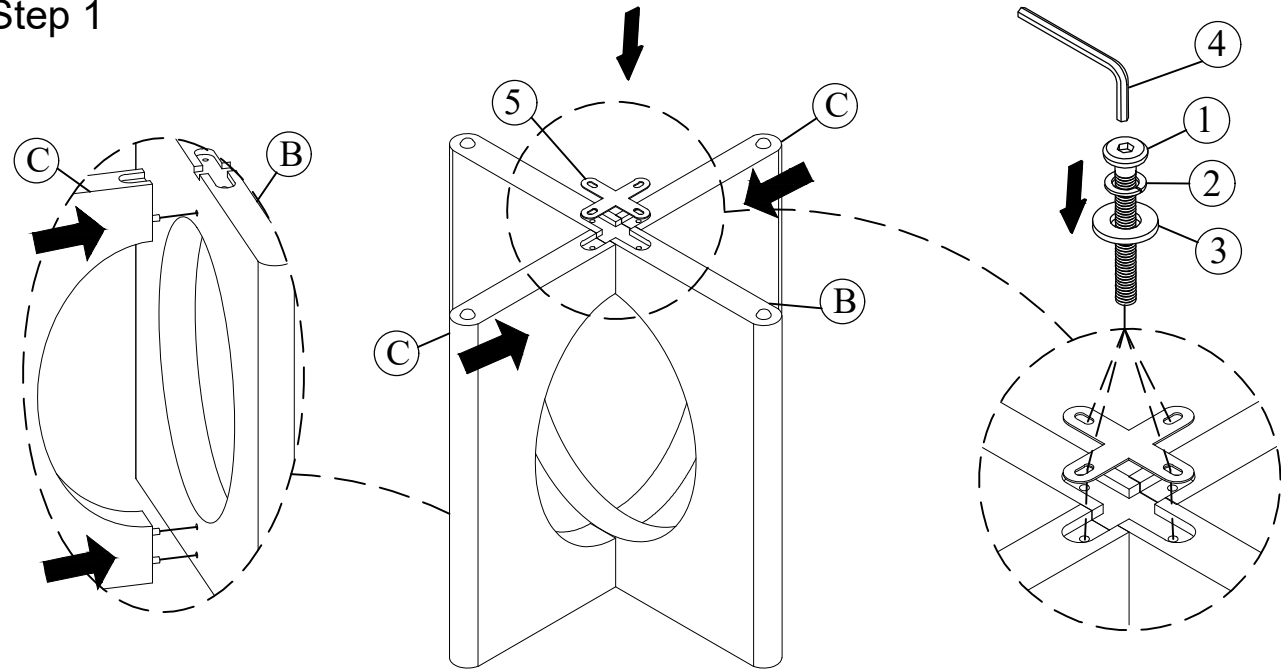

PLEASE TIGHTEN BOLTS



CVFVRD333-ASSEMBLY INSTRUCTIONS

Step 2

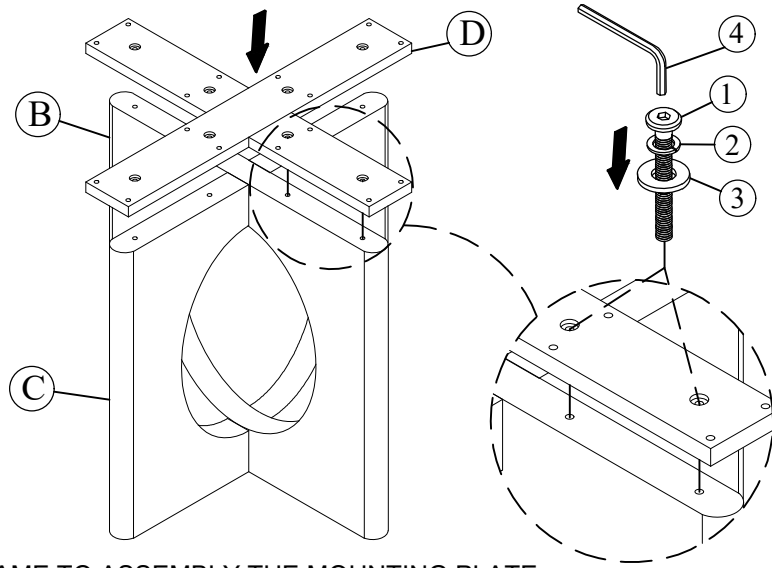

ROTATE THE BASE FRAME TO ASSEMBLY THE MOUNTING PLATE

Step 3

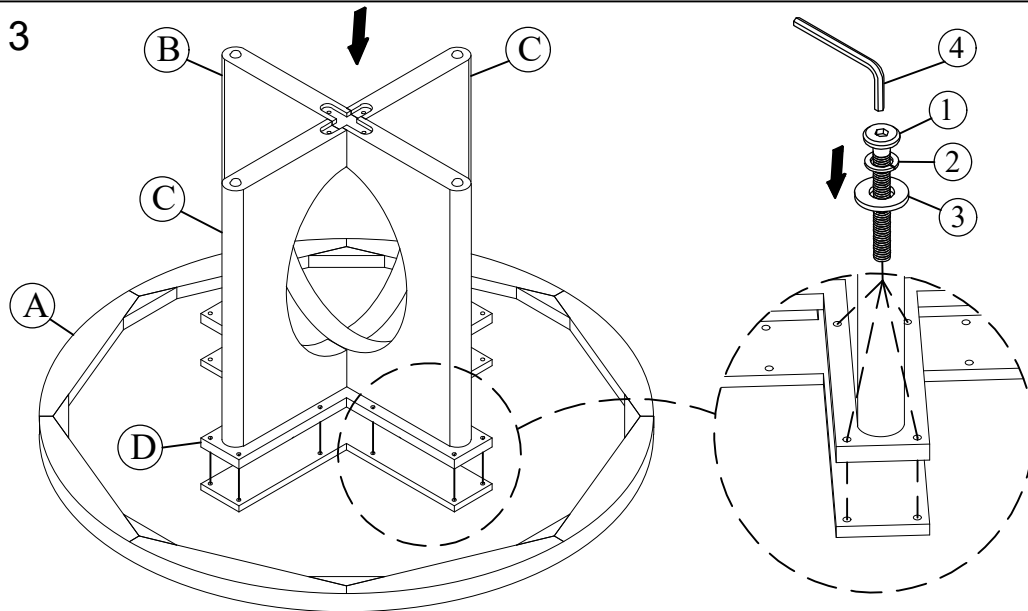

Step 4

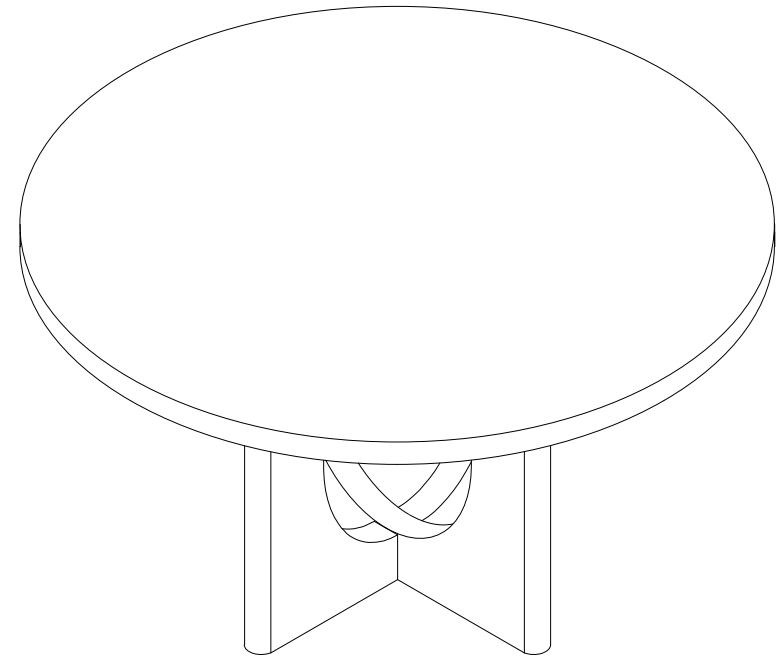

Leveler