

EN:

CAUTION:

* Before using the chair, check to ensure that all screws are fully tightened.

To remove odor, air the chair outdoors in shade for 1-2 days.



Periodically retighten all screws. Do not use an electric screwdriver.

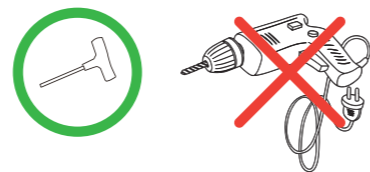

ES:

PRECAUCIÓN:

* Antes de usar la silla, Antes de usar la silla, compruebe que todos los tornillos estén completamente apretados.

Para eliminar el olor, airee la silla al aire libre, a la sombra, durante 1-2 días.



Reapriete periódicamente todos los tornillos. No utilice un atornillador eléctrico.

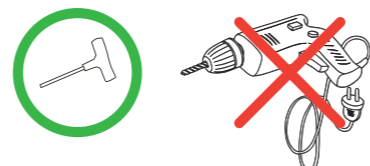

FR:

ATTENTION :

* Avant d'utiliser la chaise, vérifiez que toutes les vis sont complètement serrées.

Pour éliminer les odeurs, aérez la chaise à l'extérieur à l'ombre pendant 1 à 2 jours.



Resserrez périodiquement toutes les vis. N'utilisez pas de tournevis électrique.

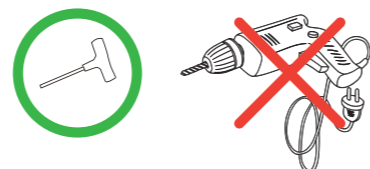







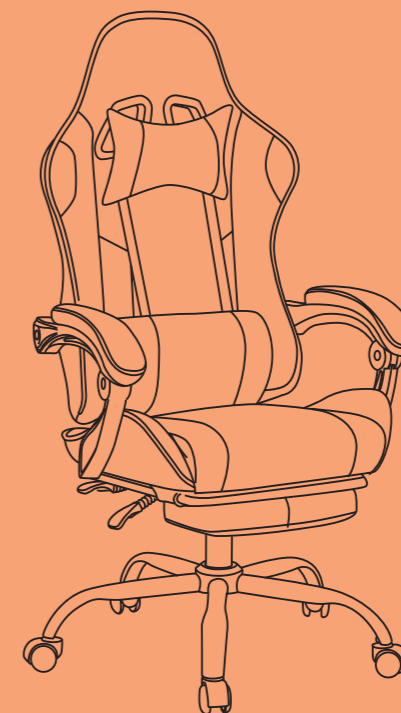





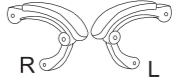



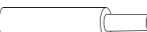

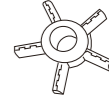
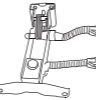
Safety Information / Información de seguridad / Informations Relatives à la Sécurité



**INSTRUCTION MANUAL
MANUAL DE INSTRUCCIONES
MANUEL D'INSTRUCTIONS**

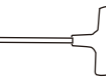

- | | | | | | |
|---|---|---|---|---|--|
| A x1
 | B x1
 | C x1
 | D x1
 | E x2
 | F x1
 |
| G x1
 | H x2
 | I x5
 | J x1
 | K x5
 | L1+L2 x1
 |
| M x1
 | N x1
 | O x6

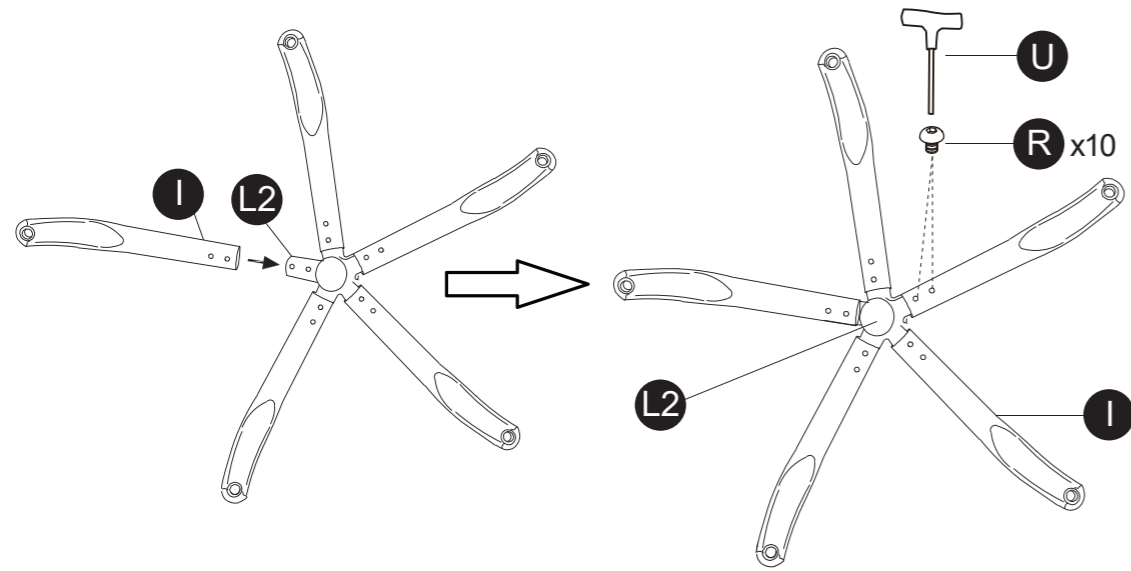
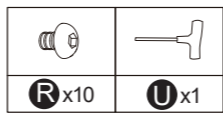
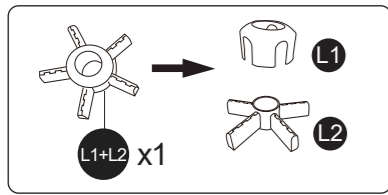
M6*25mm | P x4

M8*25mm | Q x8

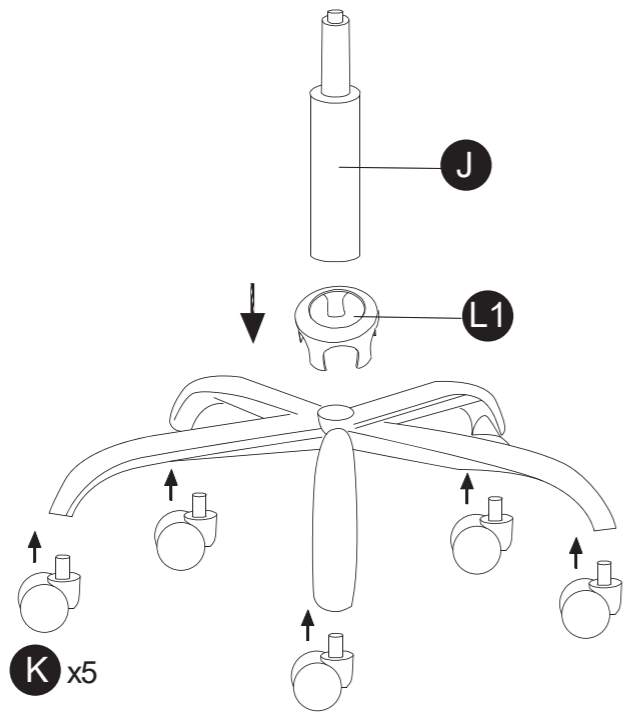
M8*20mm | R x10

M6*10mm |
| S x4

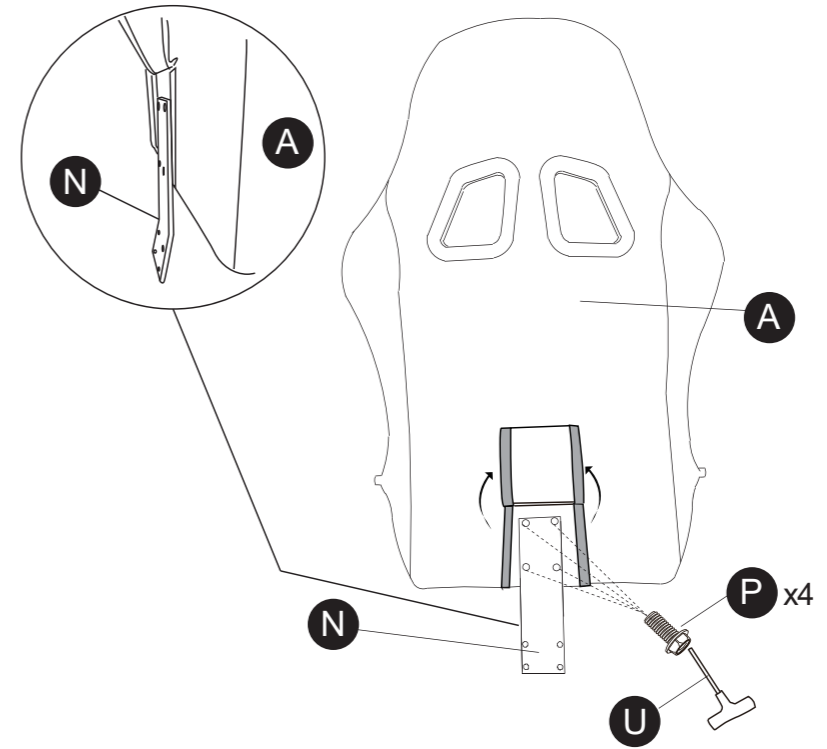
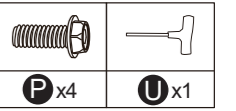
M8*40mm | T x1

M5*10mm | U x1
 | | | |



1





2

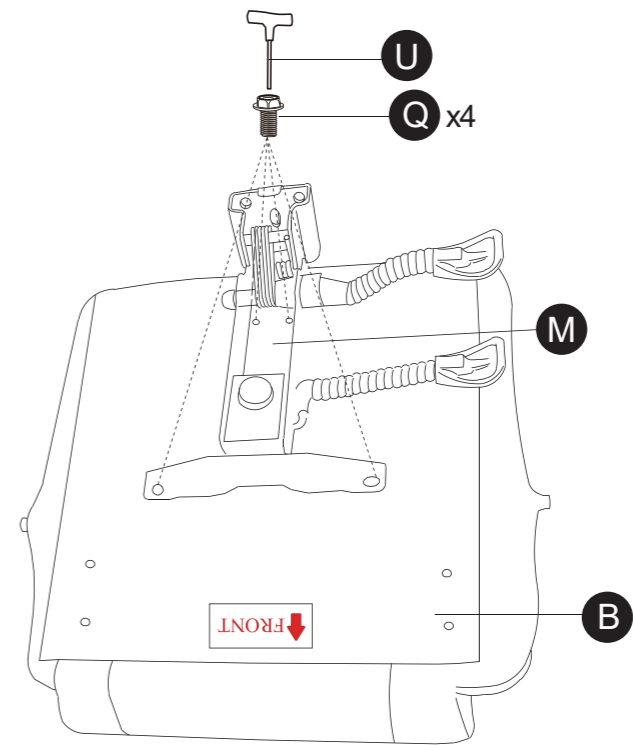
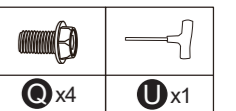

3



4

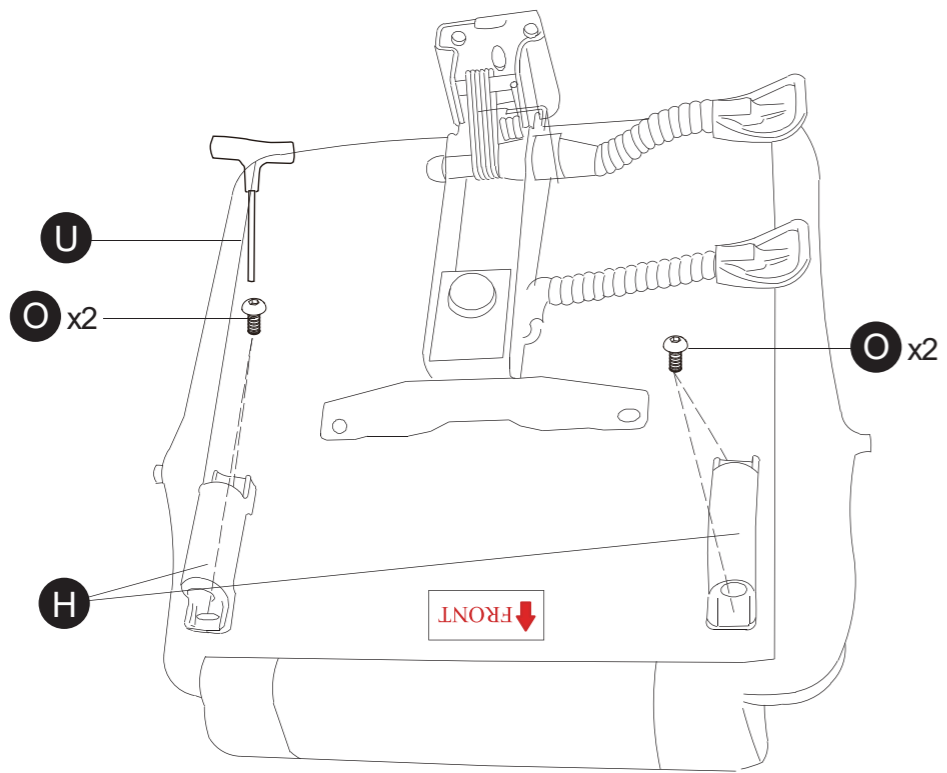

	
O x4	U x1

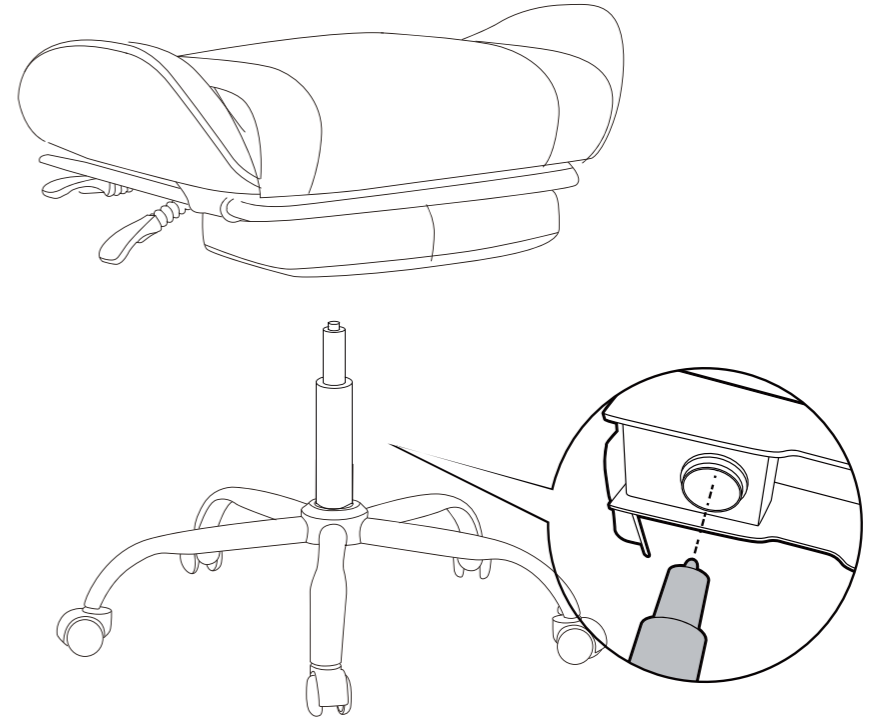

5



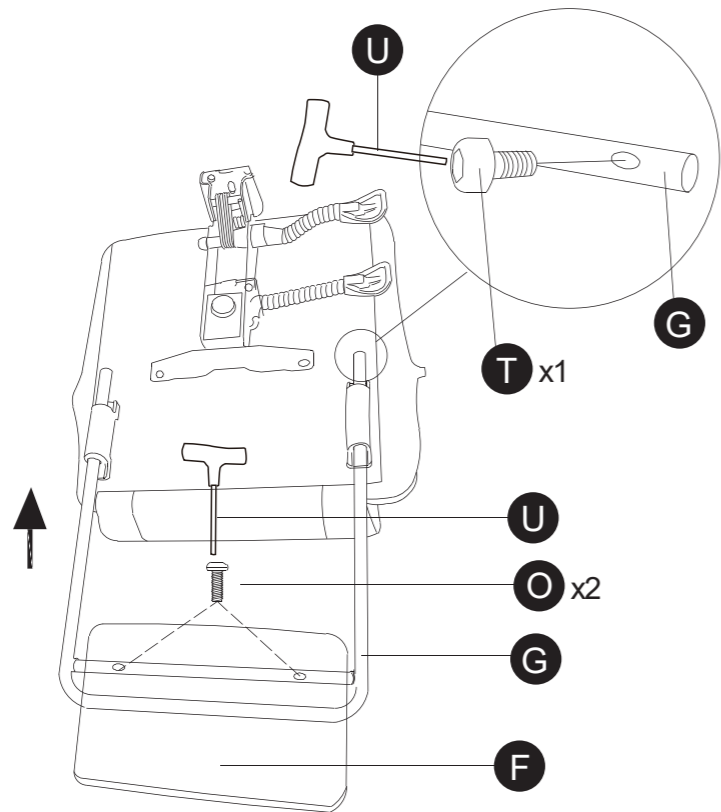

7

		
O x2	T x1	U x1



6

	
Q x4	U x1

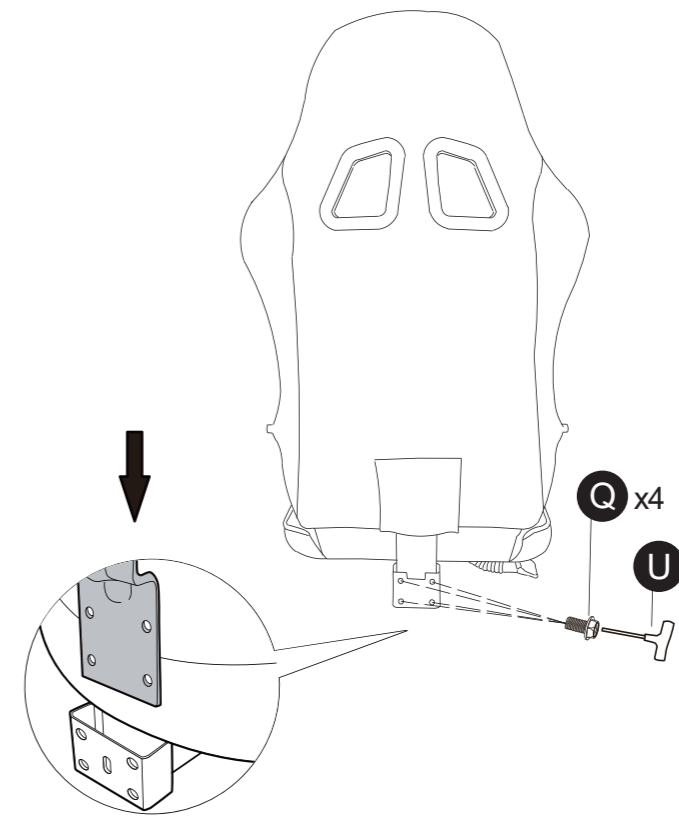

8

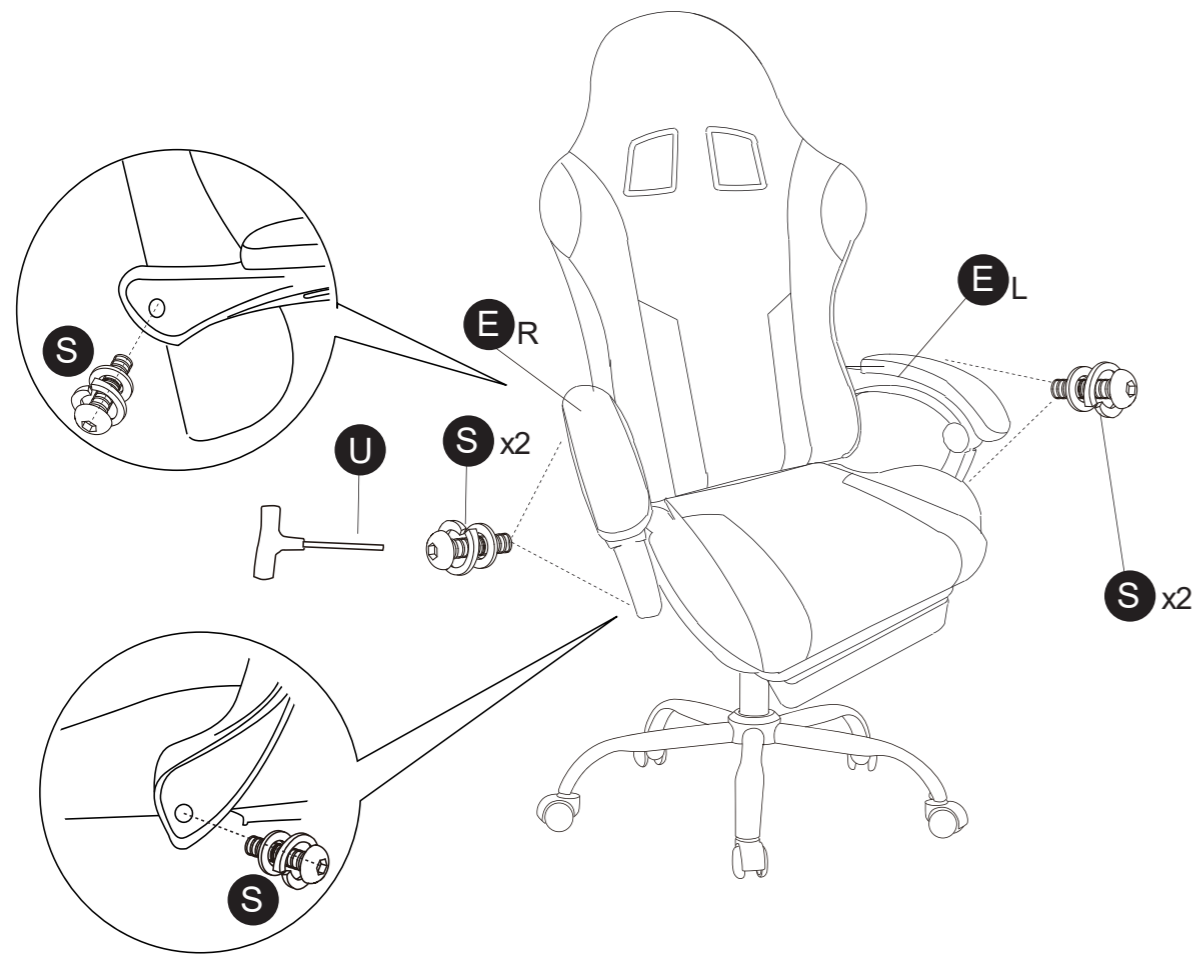
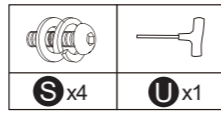

EN: **NOTE:** Do not fully tighten the screws until the assembly is complete.

ES: **NOTA:** No apriete los tornillos por completo hasta terminar el montaje.

9

FR: **REMARQUE :** Ne serrez pas complètement les vis avant que l'assemblage ne soit terminé.

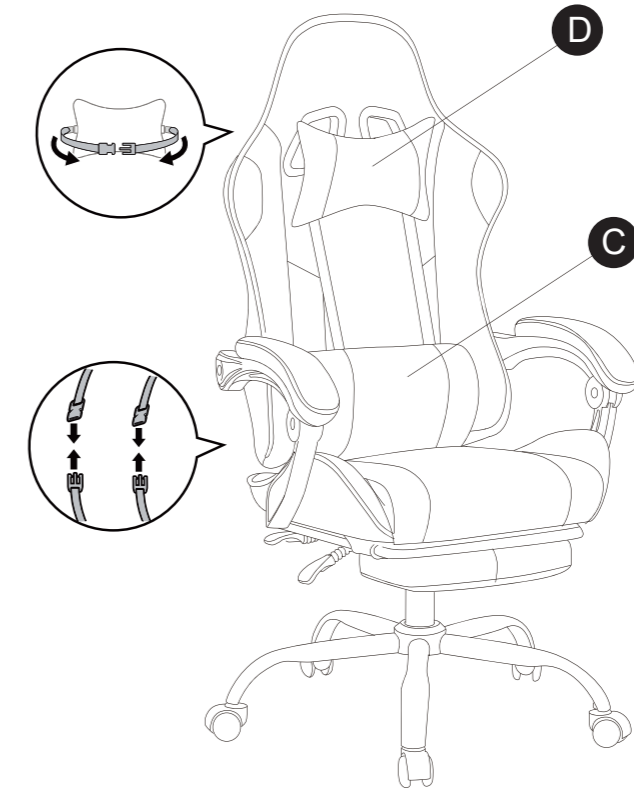

10

