

Upholstered Daybed With Trundle

Twin-Twin

Weight Limit:

Daybed: 400 LBS / 181 KG

Trundle: 250 LBS / 113 KG

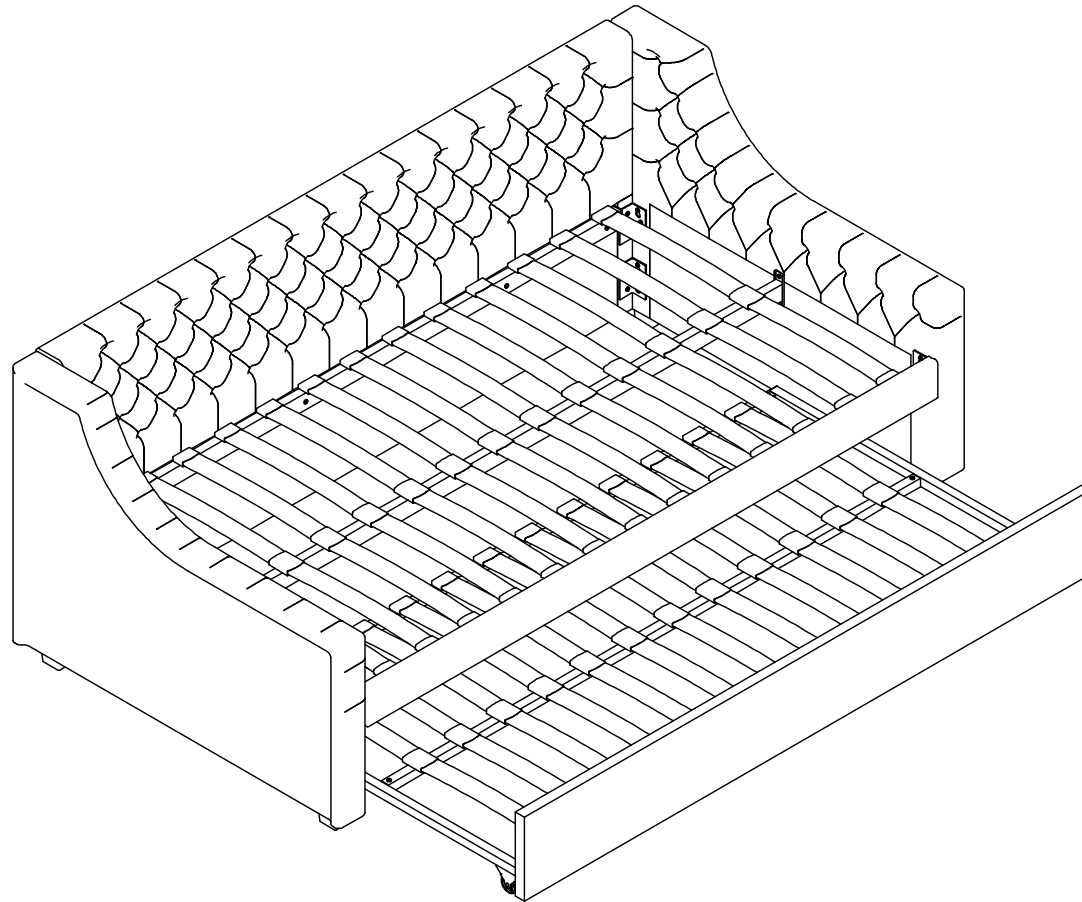

Version: 2025/12/2

PARTS

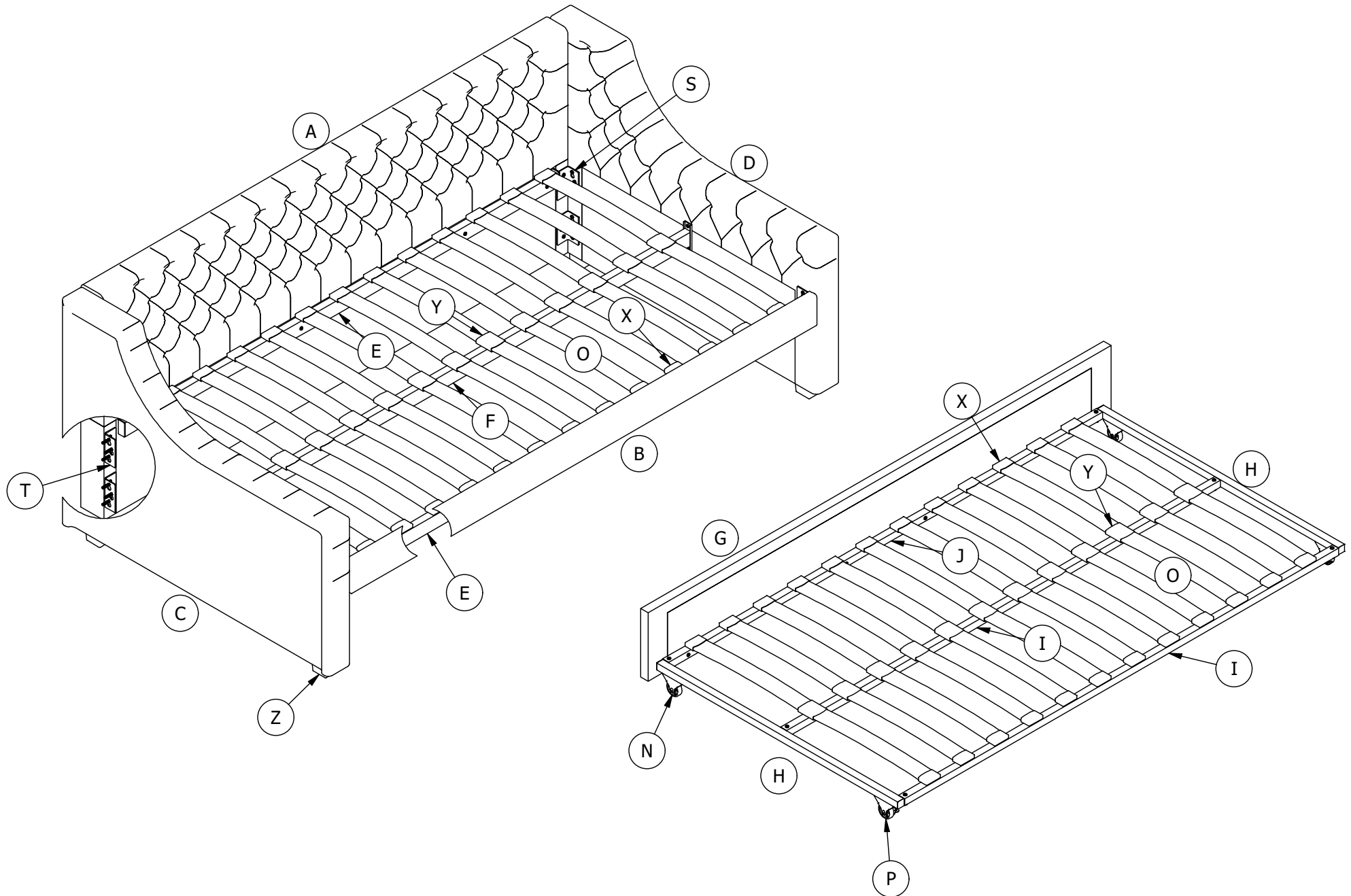

PARTS LIST - 1/2

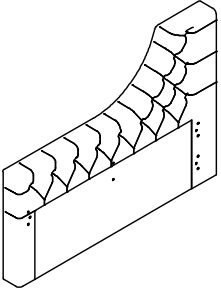
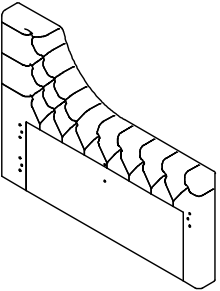
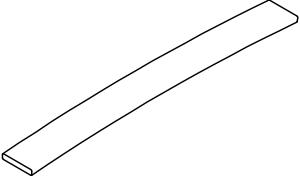
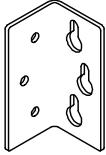
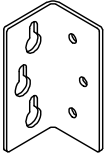
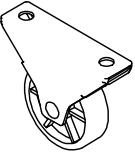
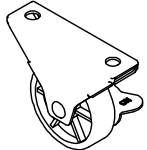
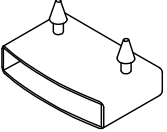
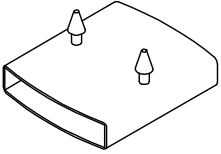
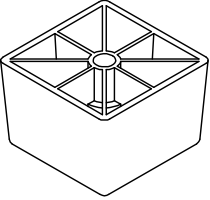
				
<p>Armrest 1 PC</p>	<p>Armrest 1 PC</p>	<p>Wooden Slat 50 PCS</p>	<p>Bracket 3 PCS</p>	<p>Bracket 3 PCS</p>
				
<p>Caster 2 PCS</p>	<p>Locking Caster 2 PCS</p>	<p>Single Slat Cap 50 PCS</p>	<p>Double Slat Cap 25 PCS</p>	<p>Leg 4 PCS</p>

PARTS LIST - 2/2

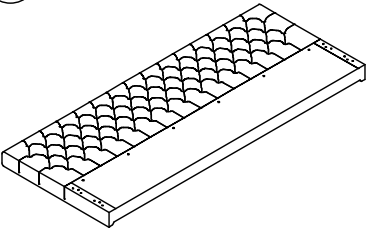
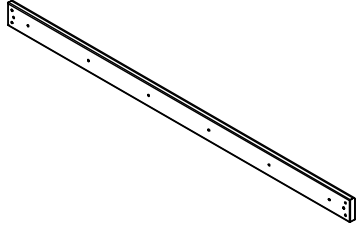
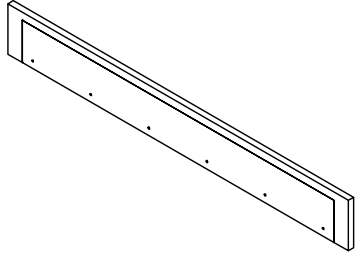
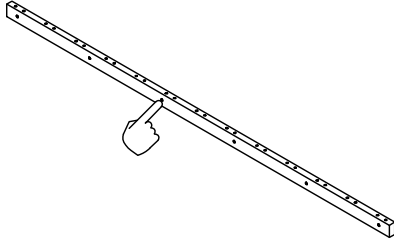
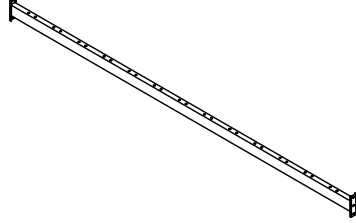
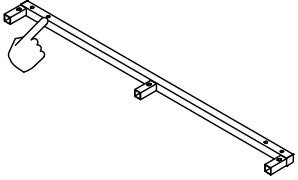
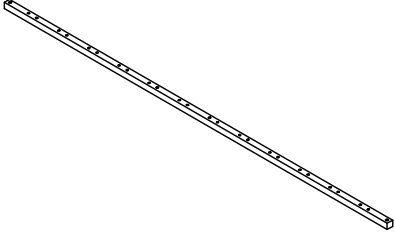
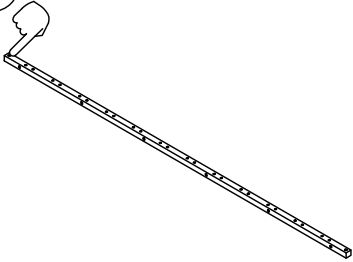
 <p>A</p>	 <p>B</p>	 <p>G</p>	 <p>E</p>	 <p>F</p>
<p>Back Rest 1 PC</p>	<p>Front Panel 1 PC</p>	<p>Front Panel 1 PC</p>	<p>Front / Rear Rail 2 PCS</p>	<p>Center Brace 1 PC</p>
 <p>H</p>	 <p>I</p>	 <p>J</p>		
<p>Side Rail 2 PCS</p>	<p>Rear Rail 2 PCS</p>	<p>Front Rail 1 PC</p>		

HARDWARE LIST

1

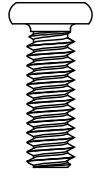

1/4" X 3/4"
Bolt
6 PCS

2

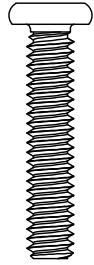

1/4" X 1 3/16"
Bolt
34 PCS

3

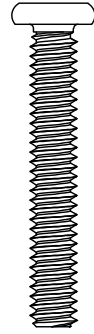

1/4" X 1 9/16"
Bolt
12 PCS

4

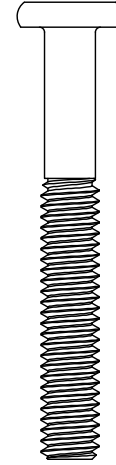

5/16" X 2 1/4"
Bolt
4 PCS

5

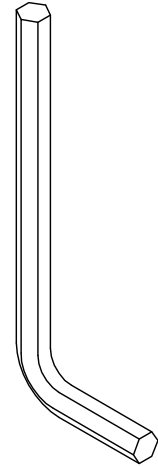

4mm
Allen Key
1 PC

HARDWARE LIST

1

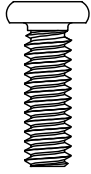

1/4" X 3/4"
Bolt
8 PCS

2

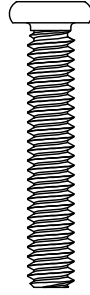

1/4" X 1 3/8"
Bolt
6 PCS

3

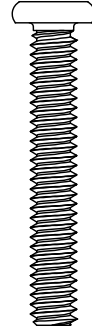

1/4" X 1 9/16"
Bolt
6 PCS

4

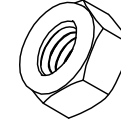

1/4"
Nut
6 PCS

5

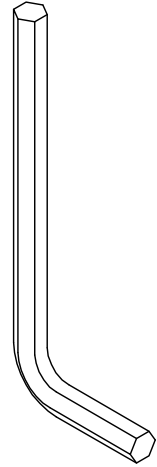

4mm
Allen Key
1 PC

6

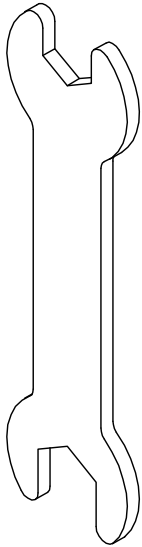

Wrench
1 PC

Step 1

The following instructions will illustrate how to assemble the Daybed from **Step 1** to **Step 6**. Please use the Daybed Hardware Pack: **T4144719LSA-01**

Attach **Z** x 4 to **C** and **D** with **4**.

Screw **2** to **C** and **D**, leave half of the thread exposed.

⚠ Do not completely tighten the Bolts, leave half of thread exposed.

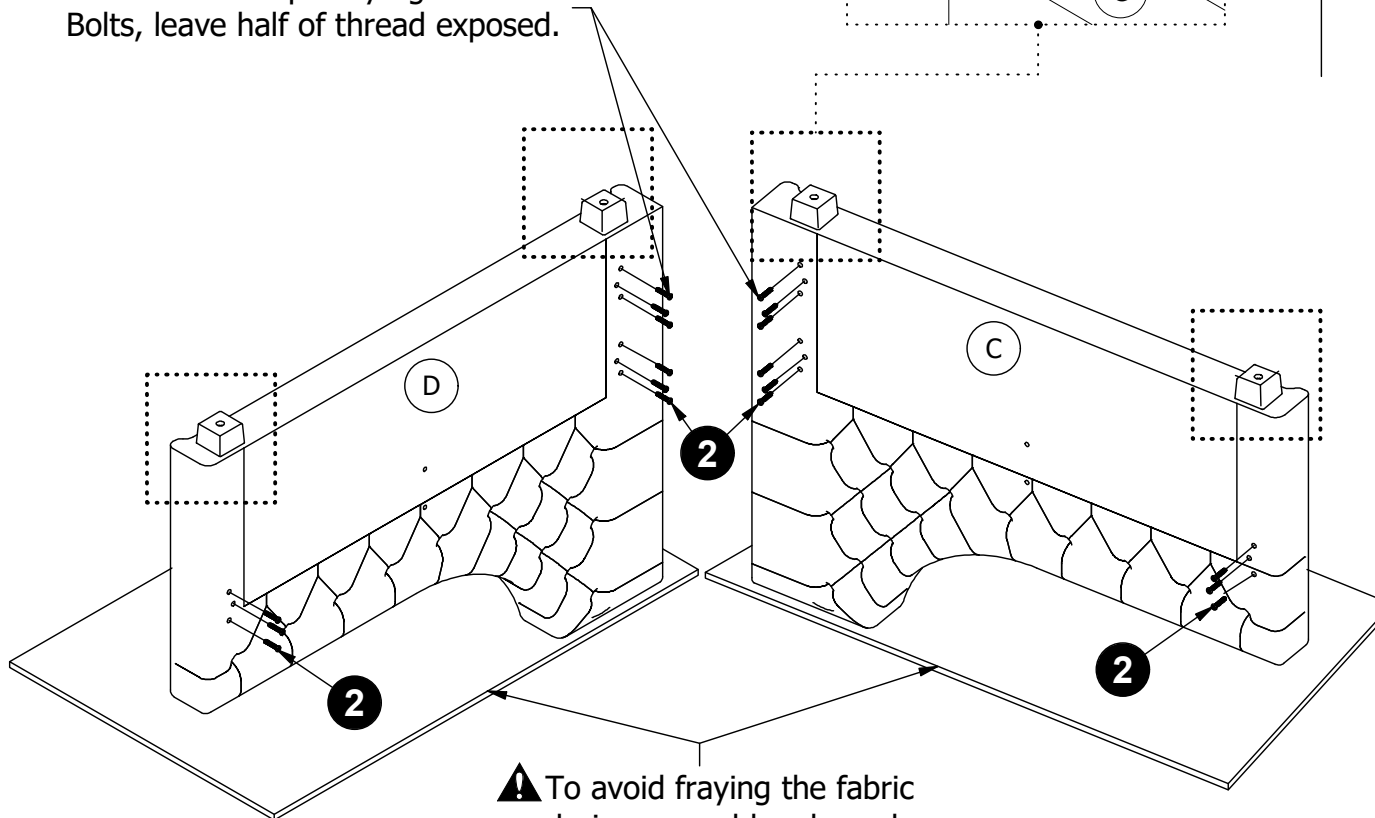
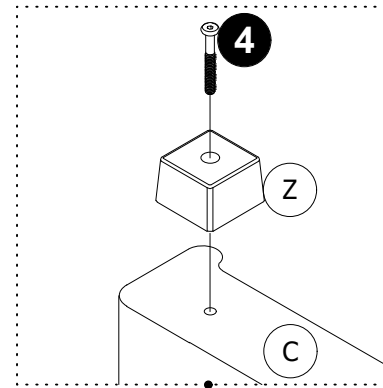

⚠ To avoid fraying the fabric during assembly, please lay the armrests **C** and **D** on a piece of cardboard.

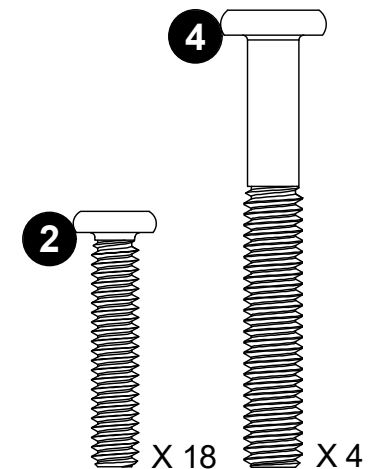

Step 2

Attach **S** x 2 and **T** x 2 and **A** with **2** .
Attach **S** and **T** to **B** with **1** .

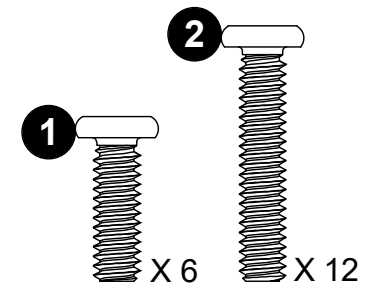
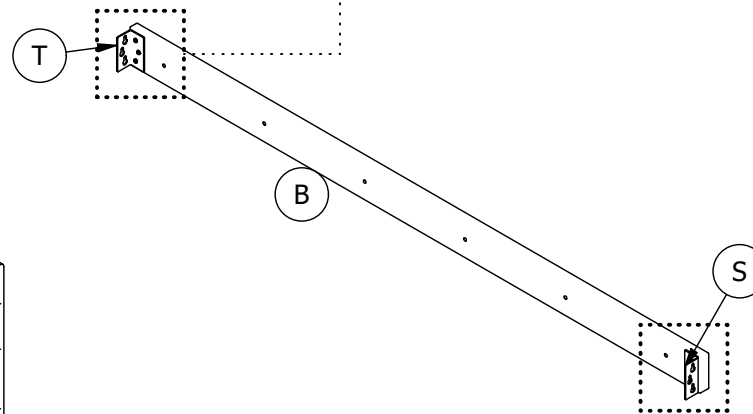
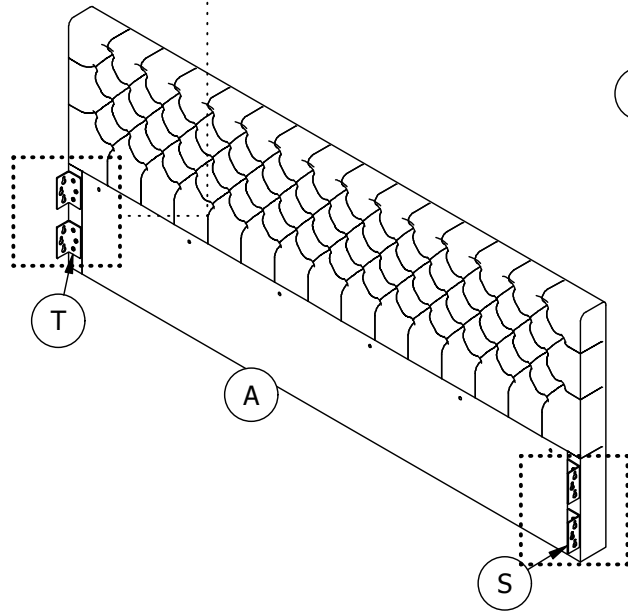
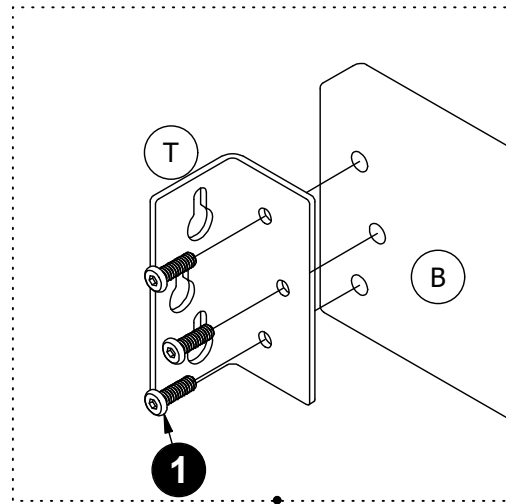
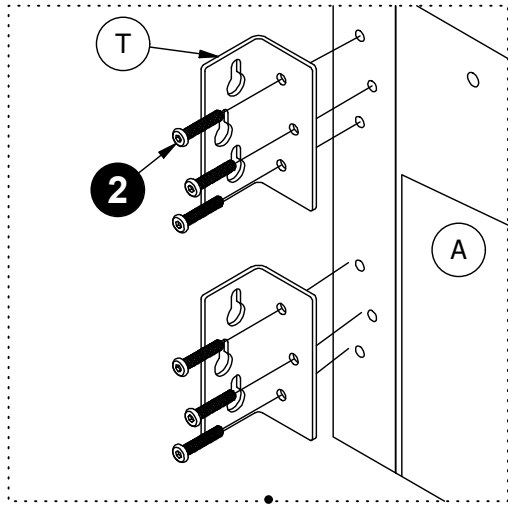

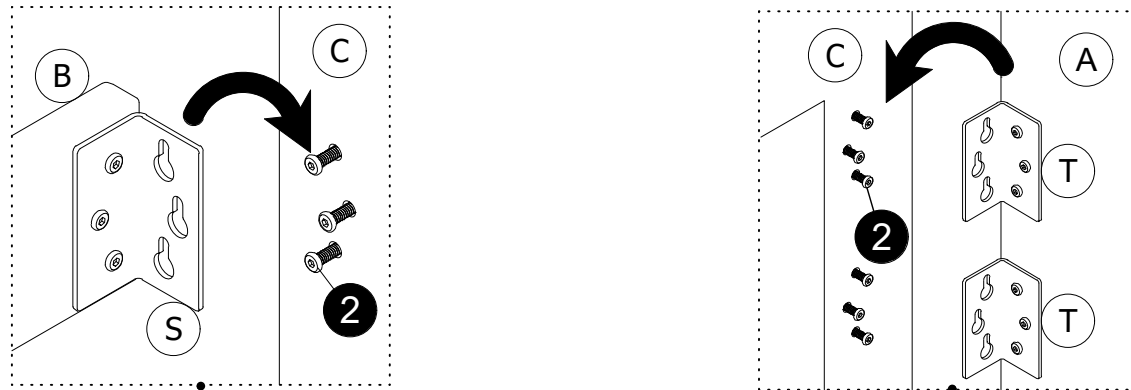

Step 3

Hang **A & B** on **C & D** as illustrated, don't completely tighten the bolts until **STEP 4** is complete.

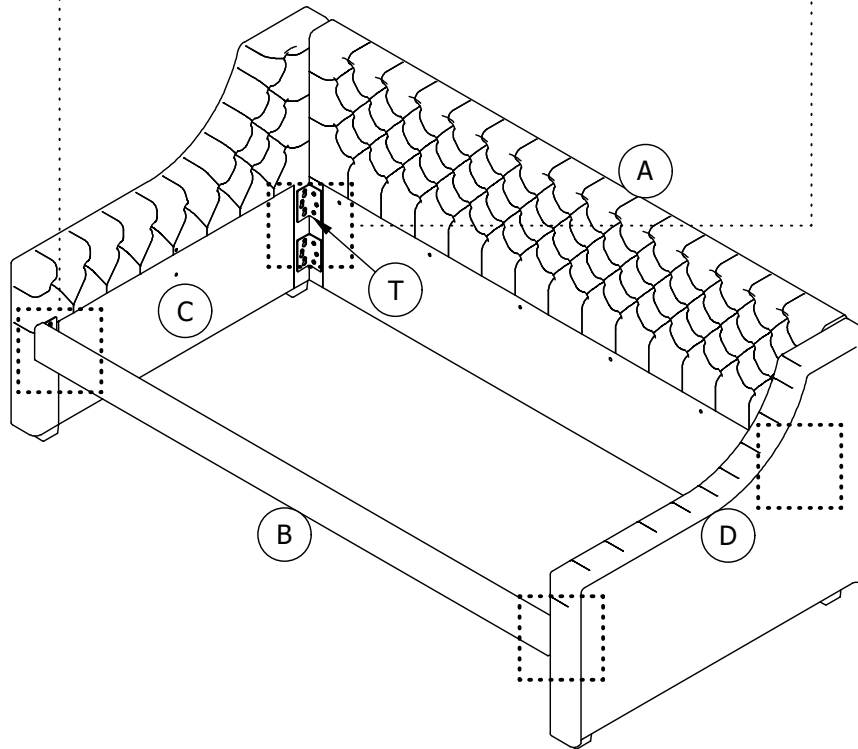

Step 4

Attach **F** to **C** and **D** with **2**.
Then properly tighten all the Bolts.

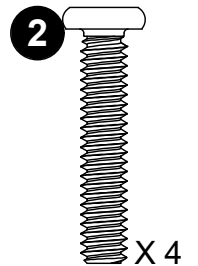
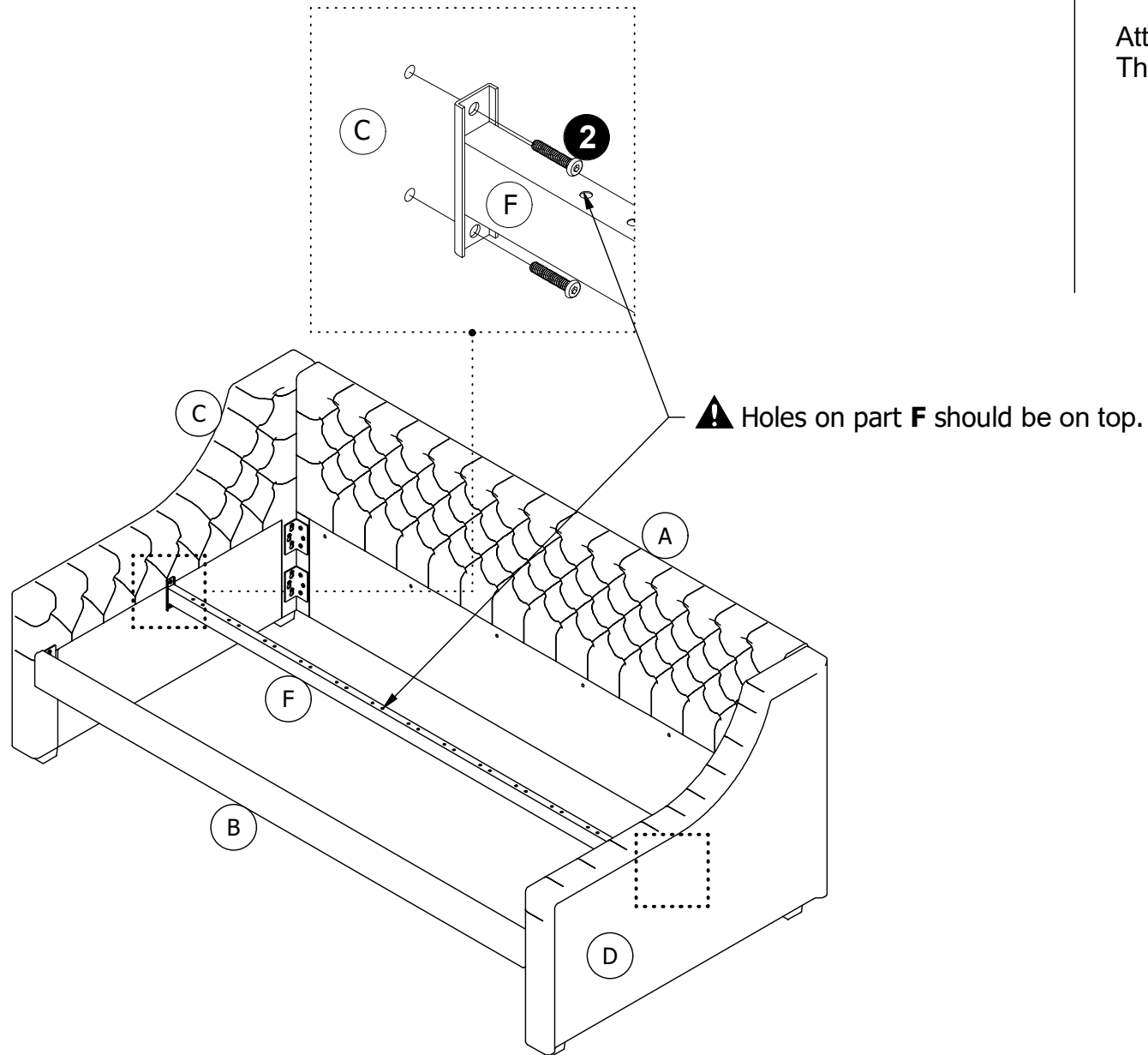

Step 5

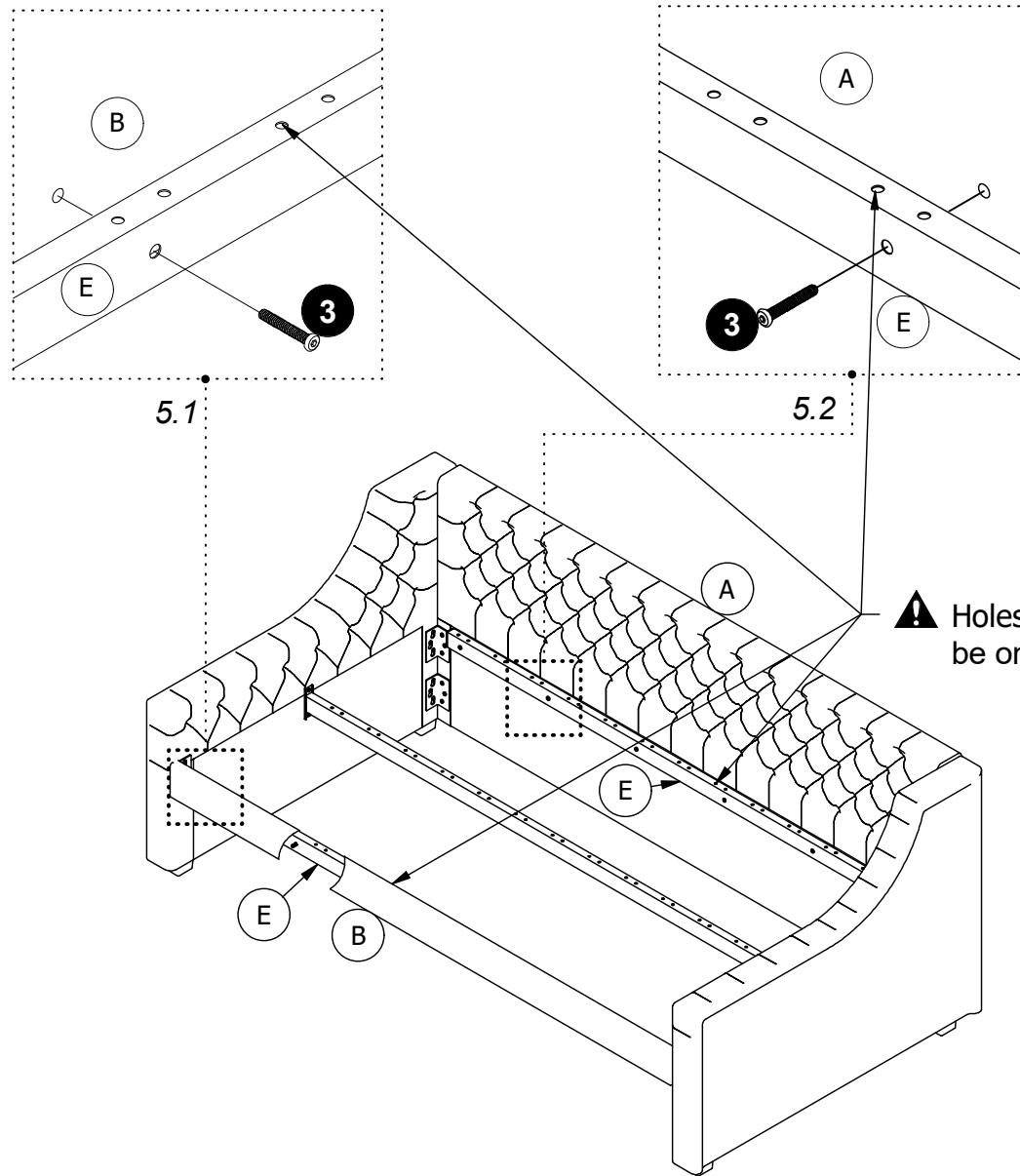

5.1 Attach one **E** to **B** with **3**.

5.2 Attach the other **E** to **A** with **3**.

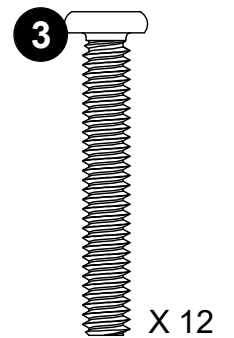

Step 6

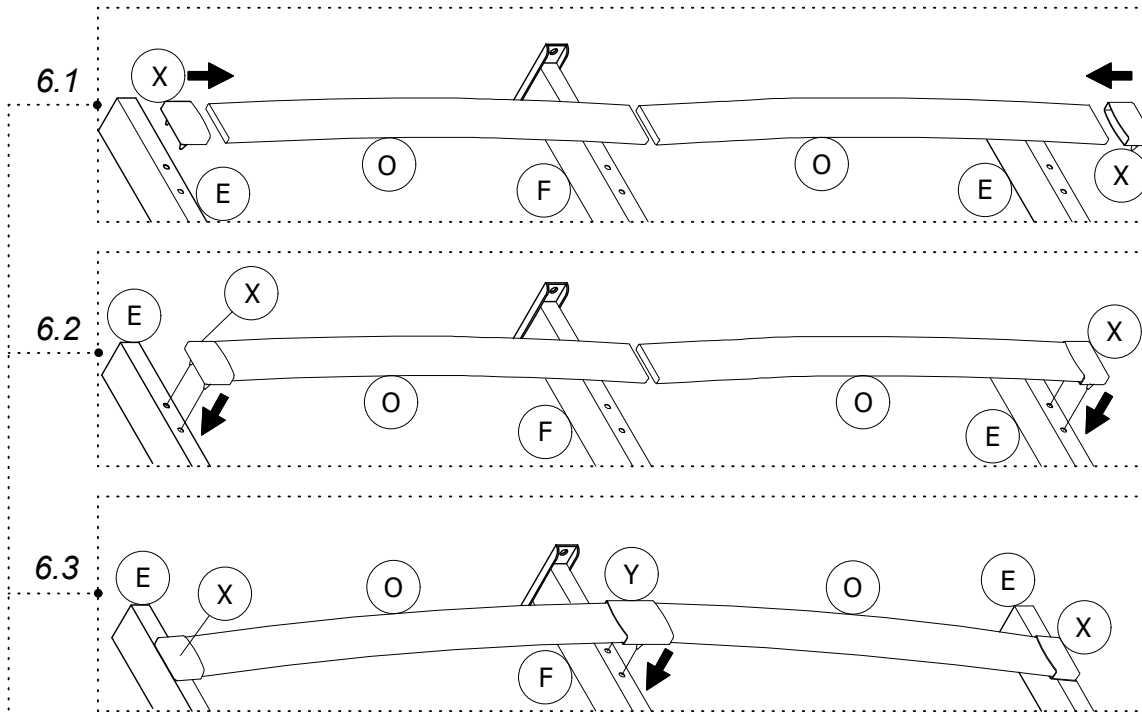

- 6.1 Insert **O** into **X**;
- 6.2 Press **X** into **E**, repeat the same procedure for the opposite side of the bed with a new **O** and **X** to press **X** into **E**.
- 6.3 Insert ends of both slat **O** into **Y**, then press **Y** into **F** as illustrated. Repeat the same procedures going backwards for every row of slats.

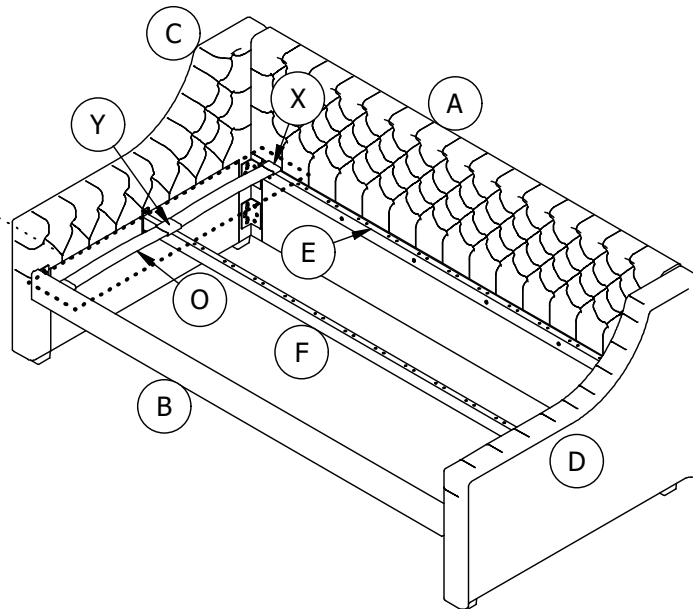

SLAT WARNING

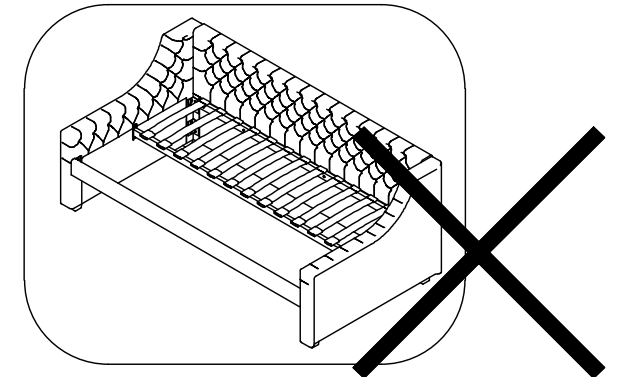
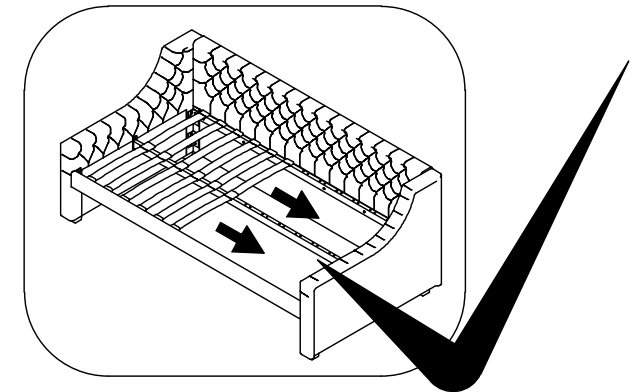
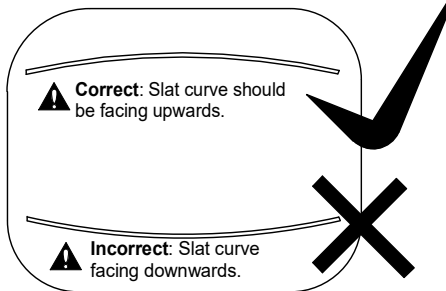

Step 7

⚠ Caster holes on **H** towards upward.

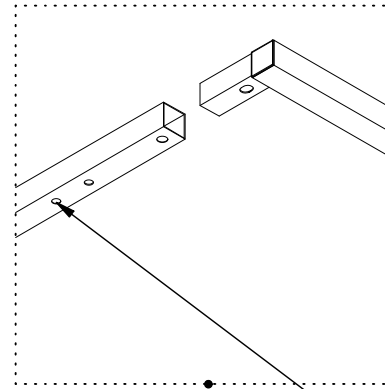
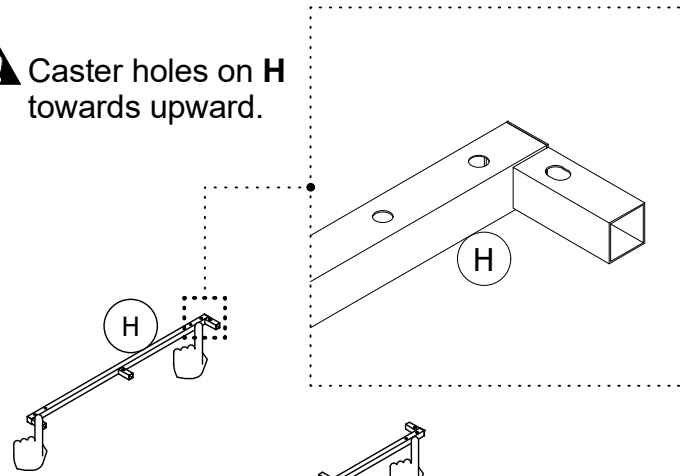

The following instructions will illustrate how to assemble the Trundle from **Step 7** to **Step 11**. Please use the Trundle Hardware Pack: **T4144719LS-02**.

7.1 Lay **H** x 2 on the floor with holes facing upward as illustrated.

7.2 Lay **J** and **I** x 2 with the slat holes facing downwards.

7.3 Insert **H** x 2 into **I** x 2 and **J** as illustrated.

⚠ Slat holes on part **I** and **J** towards floor as illustrated.

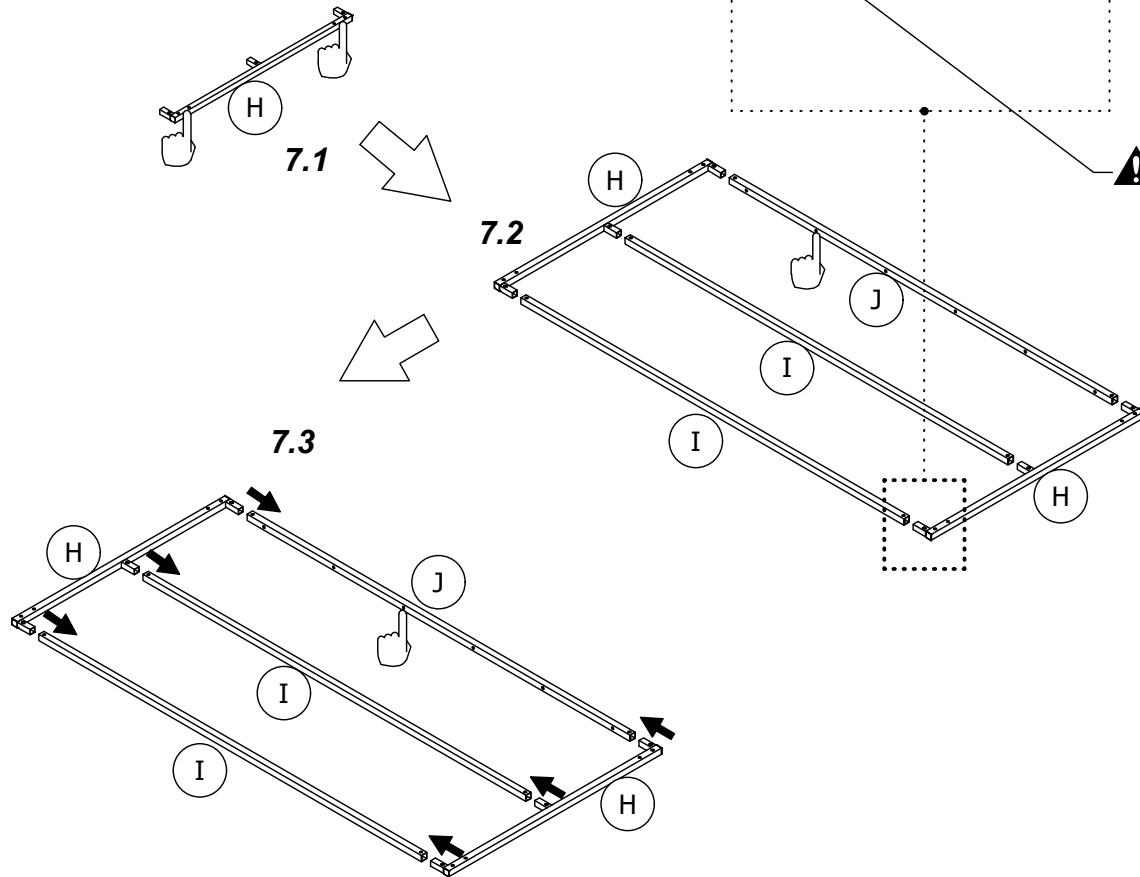

Step 8

Attach I x 2 & J to H x 2 with **2** using **5**
and **4** using **6**.

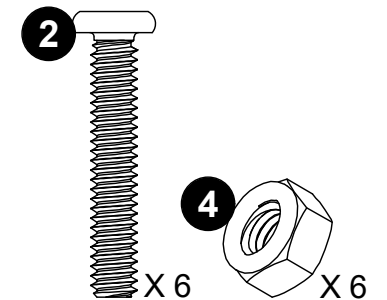
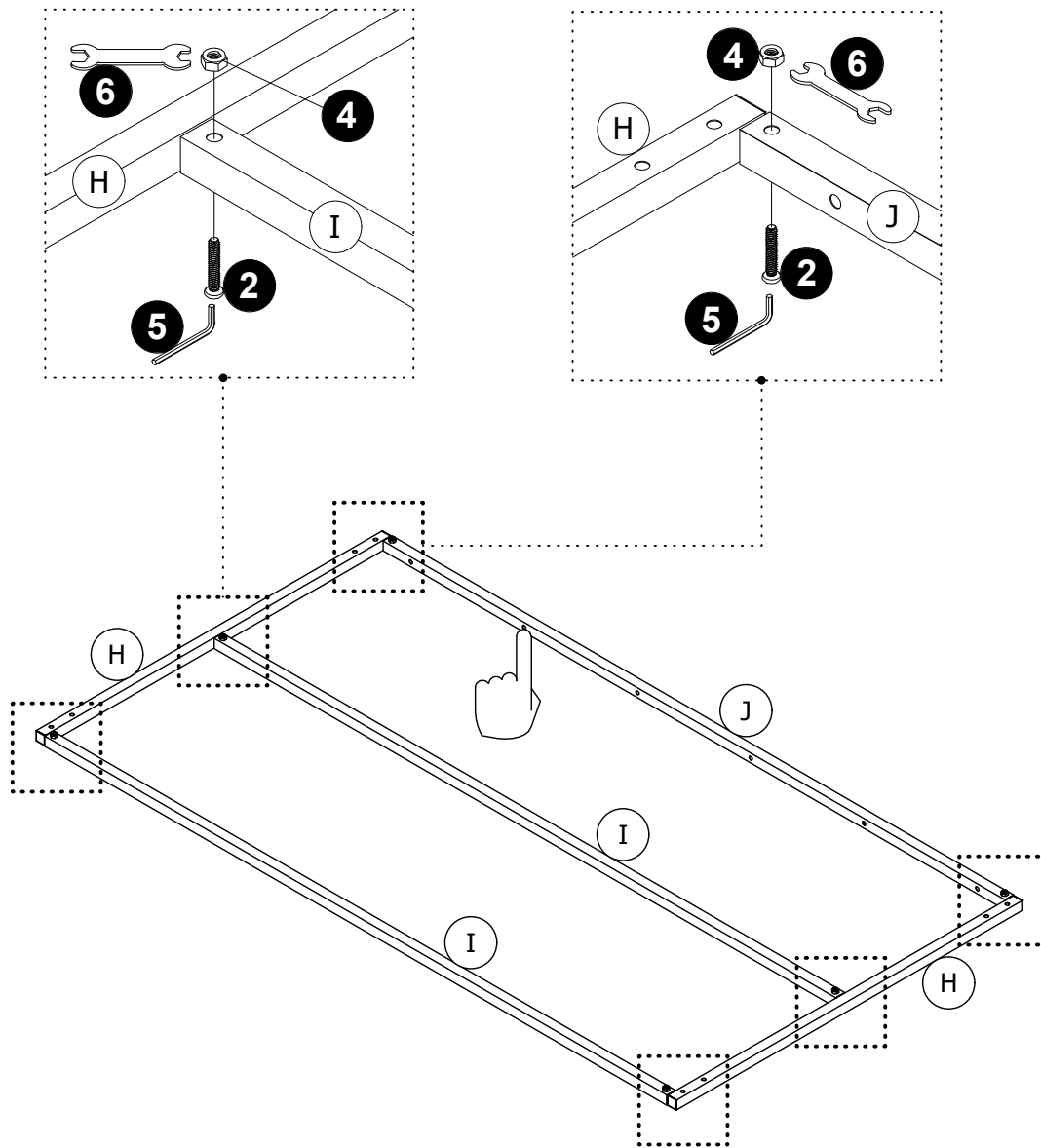

Step 9

Attach **P** x 2 & **N** x 2 to **H** x 2 with **1**.

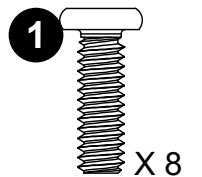
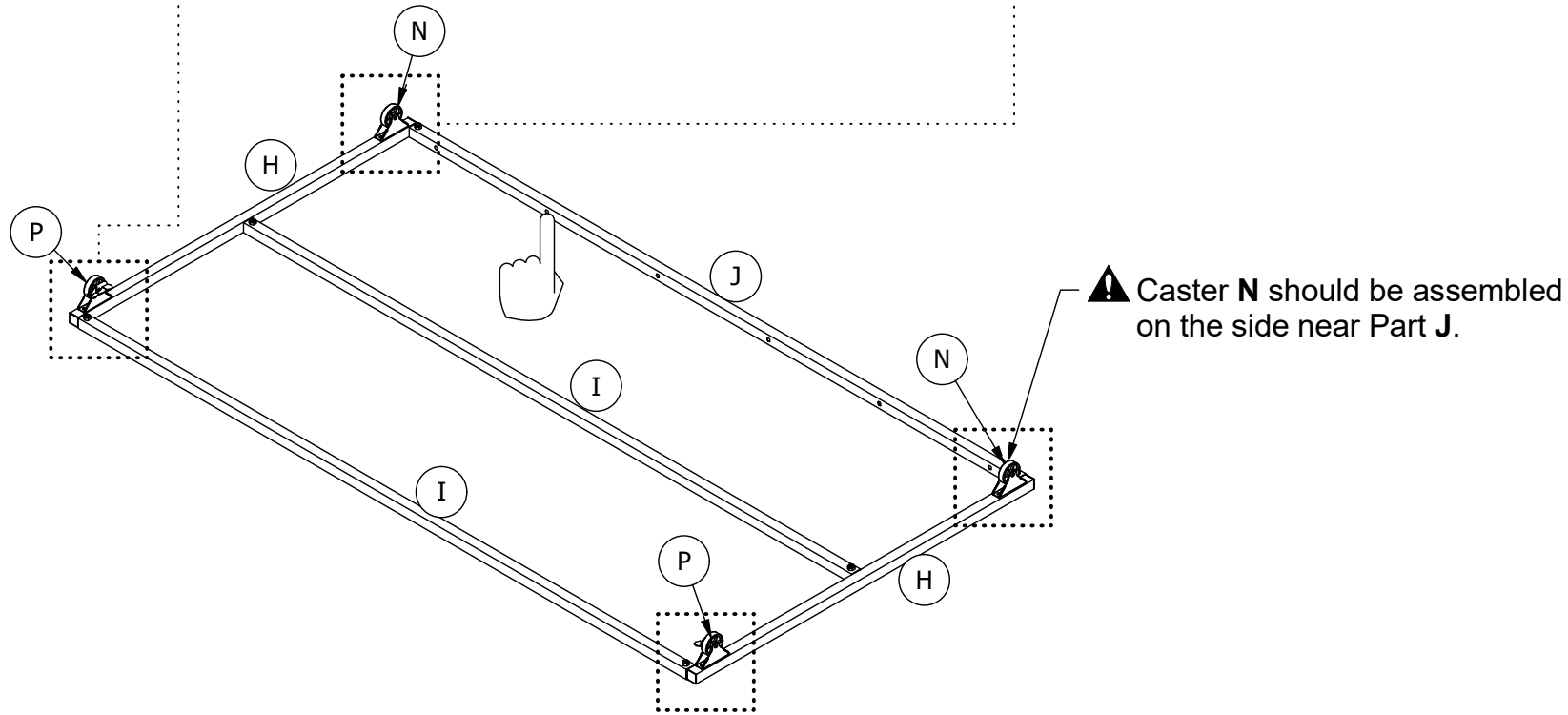
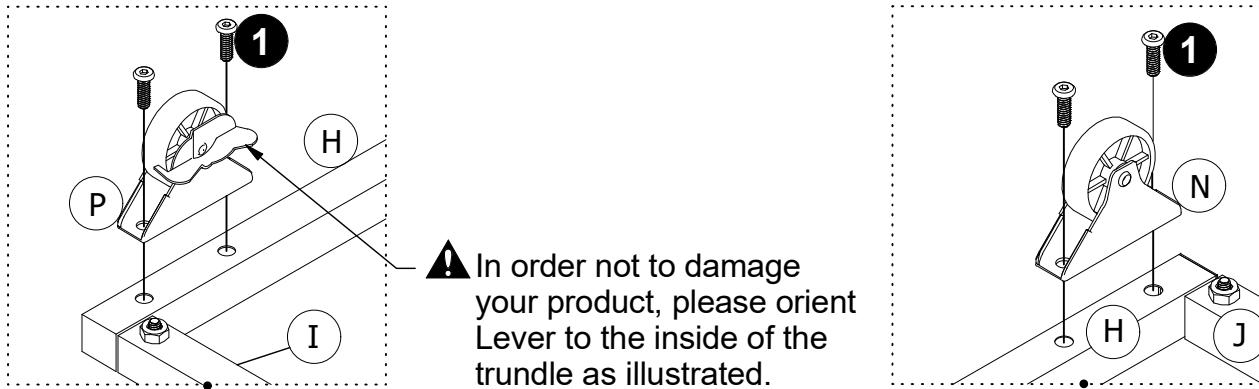

! Before assembling, please turn over the subassembly obtained from previous step with the caster on the floor.

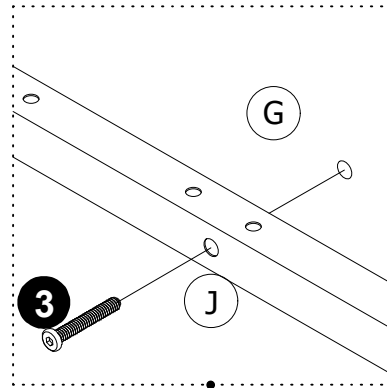

! Check if slat holes on I & J are all on the top side in this STEP.

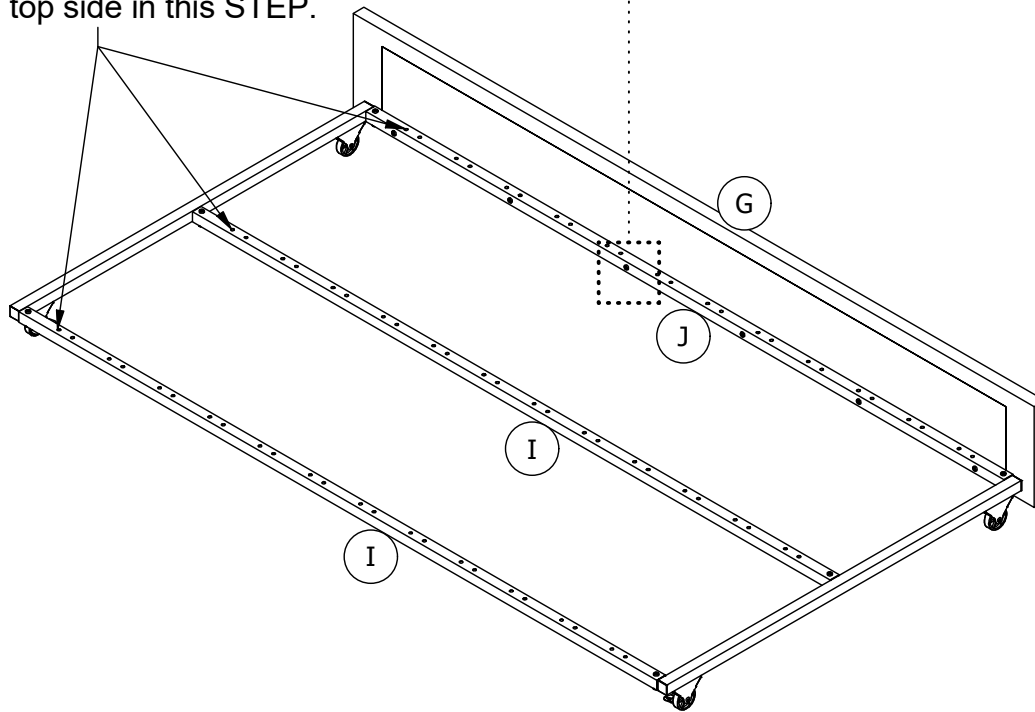

Step 10

Turn over the frame assembled from **STEP 9**.

Attach **G** to **J** with **3**.

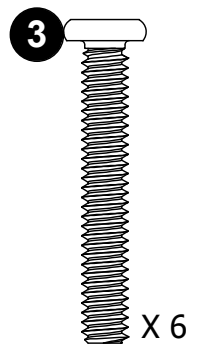

Step 11

11.1

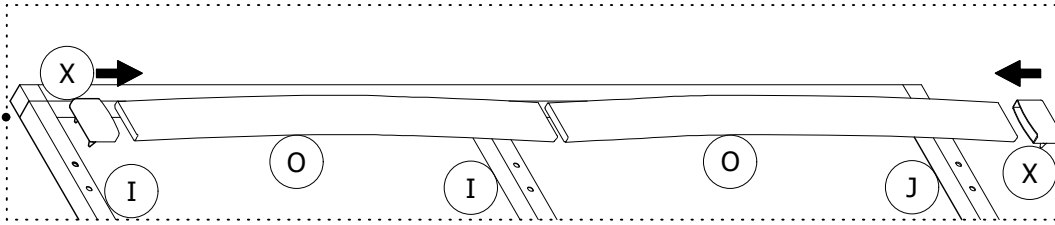

11.2

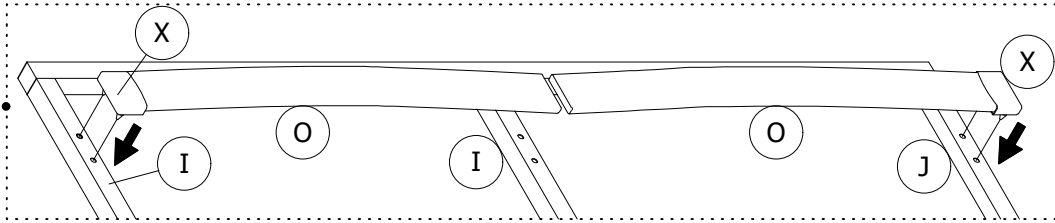

11.3

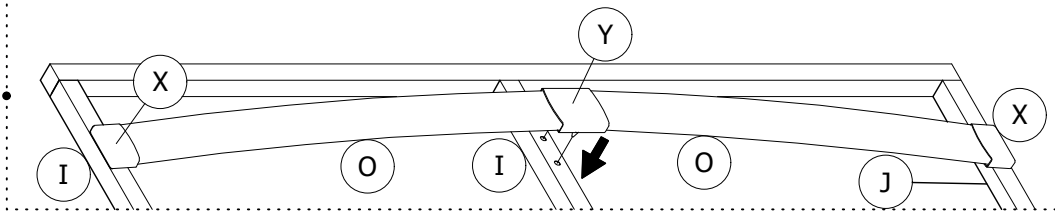

- 11.1 Insert one side of both **O** into **X** as indicated;
- 11.2 Press **X** into **I / J** on each side.
- 11.3 Insert the other free end of both slats **O** into **Y** where both **O** meet, then press **Y** into **I**.

Repeat the same procedure going backwards for every row of slats..

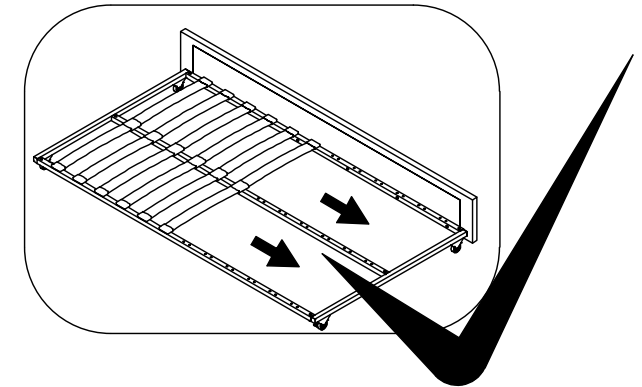

SLAT WARNING

▲ Correct: Slat curve should be facing upwards.

▲ Incorrect: Slat curve facing downwards.

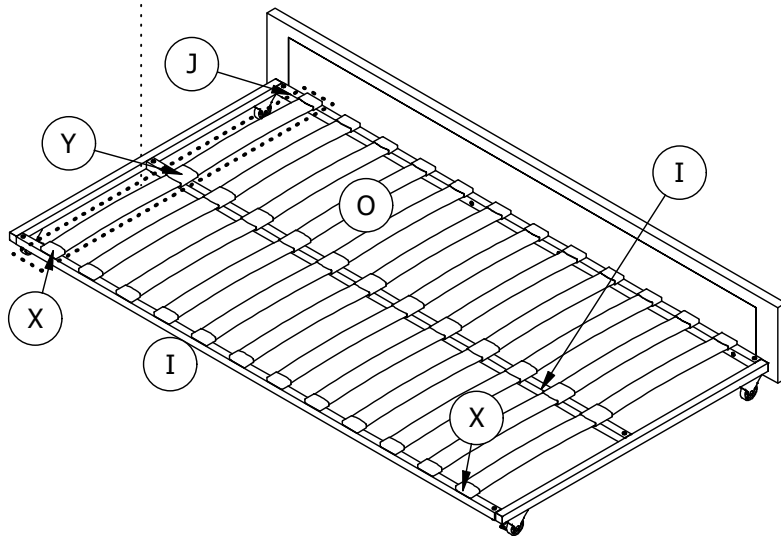
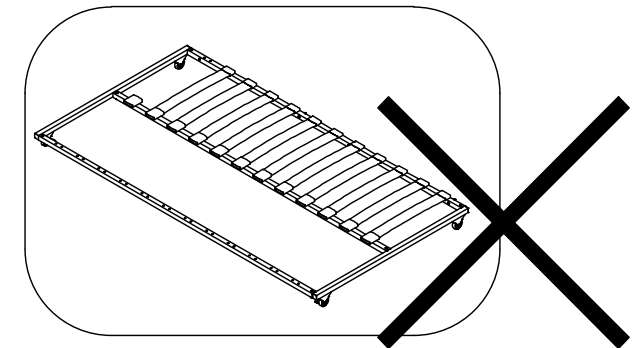

Helpful Hints

How to lock caster?

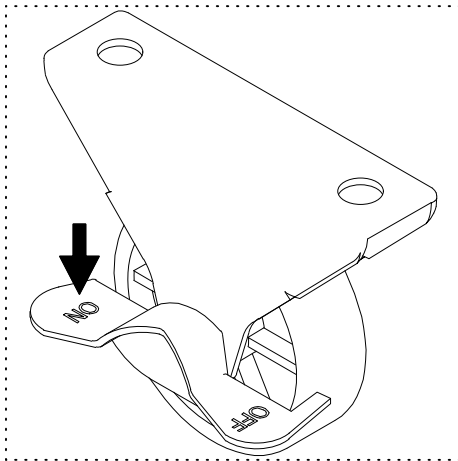

How to unlock caster?

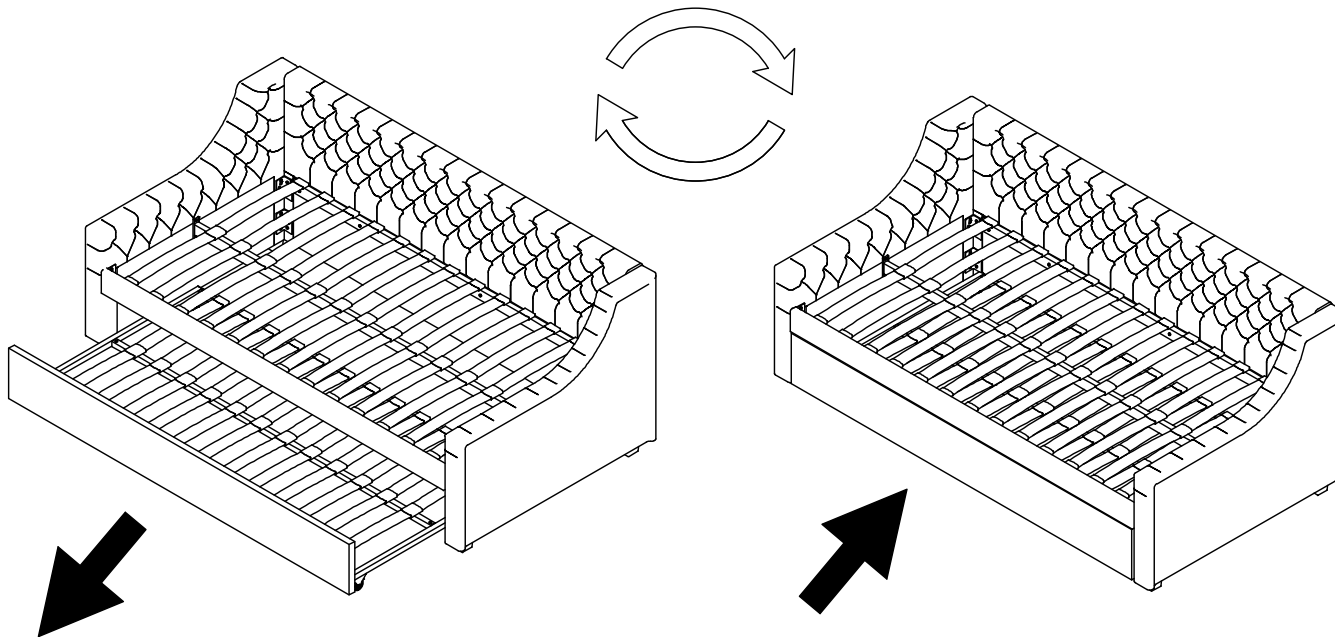
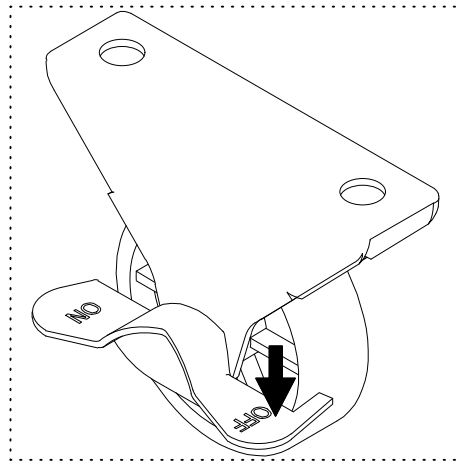

To use Trundle:

Pull out the trundle completely from underneath daybed. Once positioned, make sure casters are locked by pushing down the lever "ON" as illustrated "How to lock caster!".

To store Trundle:

Unlock the casters by pushing down the lever "OFF" as illustrated "How to unlock caster!" and push in the Trundle underneath the Daybed.

⚠ WARNINGS:

Keep casters in lock condition under normal use to prevent unintentional movement which may lead to instability and tipping.

⚠ CAUTION: This unit is intended for use only with the products and/or maximum weights indicated. Use with other products and/or products heavier than the maximum weights indicated may result in instability or cause possible injury.

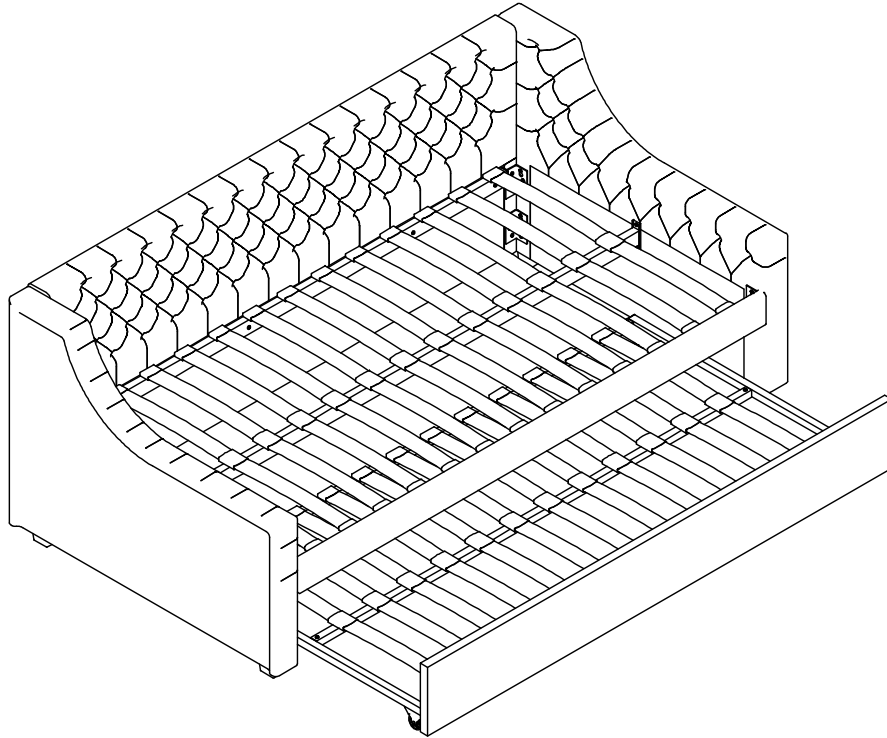

⚠ Weight Limit:
Daybed: 400 LBS / 181 KG
Trundle: 250 LBS / 113 KG

Helpful Hints

- Move your new furniture carefully, with two people lifting and carrying the unit to its new location.
- Your furniture can be disassembled and reassembled to move.
- Some parts have been pre-assembled for this item. They are illustrated on this page and available for replacement.
- Check bolts and nuts periodically and tighten if necessary.
- Clean the product with a soft damp cloth. DO NOT use harsh chemicals or abrasive cleaners.

WARNINGS:

For safety reasons and to prevent injuries:

- This bed is not intended for use by children under 4 years old.
- Prohibit jumping and horseplay on this bed.
- Only use a mattress which is 74" - 75" long and 37½" - 38½" wide.
- To optimize use of trundle, use a standard twin size mattress which is 74" - 75" long and 37½" - 38½" wide, no thicker than 6".
- Do not use risers under this bed.

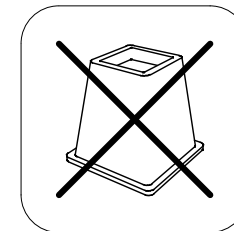

That's it ! You've finished assembling your **Upholstered Daybed With Trundle!**