

# **Smart Toilet**

## **Installation Manual**

- Thank you for choosing our products. Please read the instructions carefully before installation and keep it available for future maintenance or reference.
- The internal images in the manual are for reference only, and the actual product shall prevail.

## CONTENTS



<b>Installation</b>	<b>02</b>
Cautions And Warnings	02
Technical Specification	07
Packing List	08
Part List	09
Toilet Installation	10
Before Using	15
Function Description	16
<hr/>	
<b>Maintenance</b>	<b>19</b>
Daily Maintenance	19
<hr/>	
<b>Others</b>	<b>20</b>
Troubleshooting Guide	20
Warranty Instructions	21







## CAUTIONS AND WARNINGS

This appliance is not intended for use by persons (including children) with reduced physical, sensory or mental capabilities, or lack of experience and knowledge, unless they have been given supervision or instruction concerning use of the appliance by a person responsible for their safety.

Please read this statement thoroughly and ensure its proper use.  
Strictly adhere to all written cautions and warnings provided.

### Meaning of the Marks:

-  **DON'T:** This symbol indicates a prohibited use of the product.
-  **MUST:** This symbol is used to indicate a required step in the use of this product.

 	<p><b>Never disassemble, repair or alter. Do not use tools in places other than designated.</b></p> <ul style="list-style-type: none"> <li>• Doing so may cause fire, electrical shock, overheating, short circuit or breakdown.</li> </ul>
 	<p><b>Do not get any water or cleaning solution on the main unit or connection of power cord.</b></p> <ul style="list-style-type: none"> <li>• Doing so may cause fire, electrical shock, heat or short circuit.</li> <li>• Doing so may cause the product to crack resulting in injury or water damage.</li> </ul>
 	<p><b>Do not use the product if a malfunction occurs.</b></p> <ul style="list-style-type: none"> <li>• In case of breakdown or other problems, be sure to cut off power by flipping the power switch to OFF. Close the water shutoff valve to stop water supply.</li> </ul> <p><b>Possible malfunctions:</b></p> <ul style="list-style-type: none"> <li>• Water is leaking from a pipe or the main unit.</li> <li>• The product is cracked or broken.</li> <li>• The product makes a strange noise or emits a strange odor.</li> <li>• The product emits smoke.</li> <li>• The product is abnormally hot.</li> </ul>

## CAUTIONS AND WARNINGS

	<ul style="list-style-type: none"> <li>The toilet seat is out of place. Continued use of the product after a malfunction could result in fire, electrical shock, overheating, short circuit, injury, or water damage.</li> </ul>
DON'T	<ul style="list-style-type: none"> <li>Continued use of the smart toilet after a malfunction could result in fire, electrical shock, overheating, short circuit, injury, or water damage. Please contact professionals for assistance.</li> <li>The recommended service life of this smart toilet is 7 years. Please pay attention to the working conditions of the toilet after this period.</li> </ul>
	<p>Use tap water only.</p> <ul style="list-style-type: none"> <li>Using other types of water may cause irritation to the skin and malfunction of the product.</li> </ul>
	<p>Do not use a loose or unstable power socket.</p> <ul style="list-style-type: none"> <li>Doing so may cause fire or electrical shock.</li> </ul>
	<p>Please insert the power plug into an AC socket rated for 110V to 60Hz and 15A or above. Failure to do so may result in fire or electrical shock.</p> <ul style="list-style-type: none"> <li>If the power exceeds the socket's specification, it can cause the socket to overheat and start a fire.</li> </ul>
STOP	<p>Do not perform any actions that may damage the power plug. Avoid striking, yanking, twisting, excessively bending, damaging, altering, or heating the power cords. Additionally, do not place any heavy objects on, bind, or pinch the power cords.</p> <ul style="list-style-type: none"> <li>Using a damaged power cord may result in a fire, electrical shock, heat or short.</li> </ul>
	<p>This is an electrical product. Do not install it anywhere water is likely to get on the product or anywhere with humidity high enough that water is likely to form on the surface of this product. When using the product in a bathroom, install a fan or ventilation port and ensure good air flow through the bathroom.</p> <ul style="list-style-type: none"> <li>Failure to do so may cause fire or electrical shock.</li> </ul> <p>If the power cord is damaged, avoid danger by having the manufacturer's repair department or equivalent specialist replace it.</p>
MUST	

	<p>If the supply cord is damaged, it must be replaced by the manufacturer, its service agent or similarly qualified persons in order to avoid a hazard.</p>
MUST	<p>Children being supervised not to play with the appliance.the appliance is not to be used by persons (including children) with reduced physical, sensory or mental capabilities, or lack of experience and knowledge, unless they have been given supervision or instruction.</p> <ul style="list-style-type: none"> <li>To prevent from low-temperature burns, please do not sitting on the toilet for a long time.</li> </ul>
	<p>This appliance must be grounded.</p> <p>Connect this product only to a properly grounded power supply unit (device).</p> <ul style="list-style-type: none"> <li>Improper connection may cause electric shock.</li> </ul>
GROUND WIRE	
	<p>Do not raise the toilet seat or lid while objects are resting on top of the unit.</p> <ul style="list-style-type: none"> <li>Doing so may cause the main unit to come loose and fall, resulting in injury.</li> </ul> <p>Do not lean on cover when use this device to prevent product from damage.</p>
MUST OBEY	
	<p>Keep cigarettes and other open flames away from the product.</p> <ul style="list-style-type: none"> <li>Failure to do so may cause fire.</li> </ul>
NO FIRE	
	<p>Do not apply strong force, mechanical shock, step on or stand on the toilet seat, toilet lid or main unit. Also do not place any heavy objects on the toilet seat, toilet lid or main unit.</p> <ul style="list-style-type: none"> <li>Doing so may cause cracking or cause the main unit to come loose and fall, resulting in injury.</li> <li>Doing so may damage the product and cause injury or water damage.</li> </ul>
STOP	
	<p>Never obstruct the warm air openings of the product with fingers or any other items.Ensure that the warm air openings remain unobstructed to prevent electric shock, personal injury, or damage to the product.</p>

## CAUTIONS AND WARNINGS



STOP

Do not fold or crush the water supply hose; do not damage by cutting with a sharp object.

- Doing so may cause water leaks.

When maintaining the plastic parts (main unit etc.) or the water supply hose, use a neutral kitchen detergent diluted with water. Do not use any of the following: toilet cleaner, household cleaner, benzene, paint thinner, powdered cleanser, or nylon scrubbing brush.

- These items may damage or crack the plastic, potentially causing injury or malfunction.
- Additionally, these items could damage the water supply hose and result in a water leak.

To prevent a sudden water leak, never remove the water filter drain valve while the shutoff valve is open.

- Doing so will cause water to spurt out unexpectedly.

When installing the water filter drain valve, make sure that it is securely tightened in its proper position.

- Failure to securely tighten it may cause a water leak.

If a water leak occurs, always close the shutoff valve immediately.



MUST OBEY

When the ambient temperature is expected to drop to 32°F or below, take measures to prevent damage to the pipes and hoses due to freezing.

- Frozen water pipes can cause the main unit and connected pipes to crack, potentially resulting in a water leak.
- To avoid this, regulate the room temperature to ensure that the pipes and hoses do not freeze during cold months.
- Failure to properly secure and tighten connections may also cause a water leak.

- Avoid exposing the product to direct sunlight, as this may cause changes in color or malfunction.

- Do not urinate on the main unit, toilet seat, or wand, as this may result in failure or discoloration.



MUST OBEY

- Disconnect the power cord during thunderstorms.
- When the product will not be used for a long period of time, close the shutoff valve and then turn off the power to the product.
- When the product is not used for a long time, remove the battery in the 9V battery box to prevent the battery leakage from damaging the battery box.

- The required water pressure should be between 0.18MPa and 0.5MPa.
- Use the water supply hose provided with the product. Old water supply hoses cannot be used.

- During daily use of the remote control, keep it away from water to prevent water from getting inside the remote control. And please return it to the holder after each use.
- When the product has been used for a long period of time, replace the batteries in the remote control.

## TECHNICAL SPECIFICATIONS

Product Name	Smart Toilet
Rated Voltage	110-120V
Rated Frequency	60Hz
Rated Power	45W
Flush Volume	1.28GPF(4.8LPF)
Waterproof Level	IPX4
Heated Seat Temperature	4 levels (Room Temperature- 105°F)
Operating Temperature	41-104°F
Water Entry Temperature	33.8-95°F
Supply Water Pressure	26-73 PSI (0.18MPa-0.5MPa)
Minimum Water Pressure	26PSI, and the minimum water flow should be 5.3gpm
Codes/Standards	ASME A112.19.2-2018/CSA B45.1-18 ASME A112.4.2-2021/CSA B45.16:21

- Maximum temperature of the water supplied by the product for hygiene purposes: 107°F.
- No further notice will be provided if any technical specifications change due to product improvement or technical updates. All actual technical specifications are subject to the final product.

## PACKING LIST

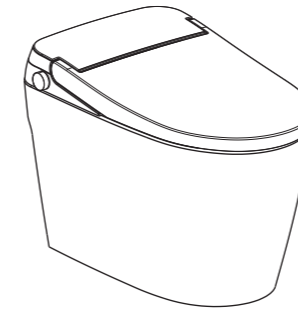

Main Unit



9V Battery Box (No battery included)

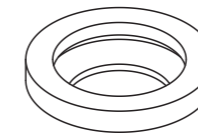

Wax Ring



1/2 inch-to-9/16  
inch Adapter



Installation Manual and  
Certificate Of Competency

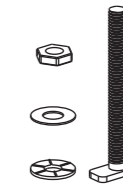

T-bolts

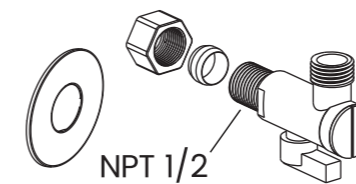

Angle Valve



Flow Regulator



1/2 inch-to-3/4  
inch Adapter

## PART LIST

### Left side

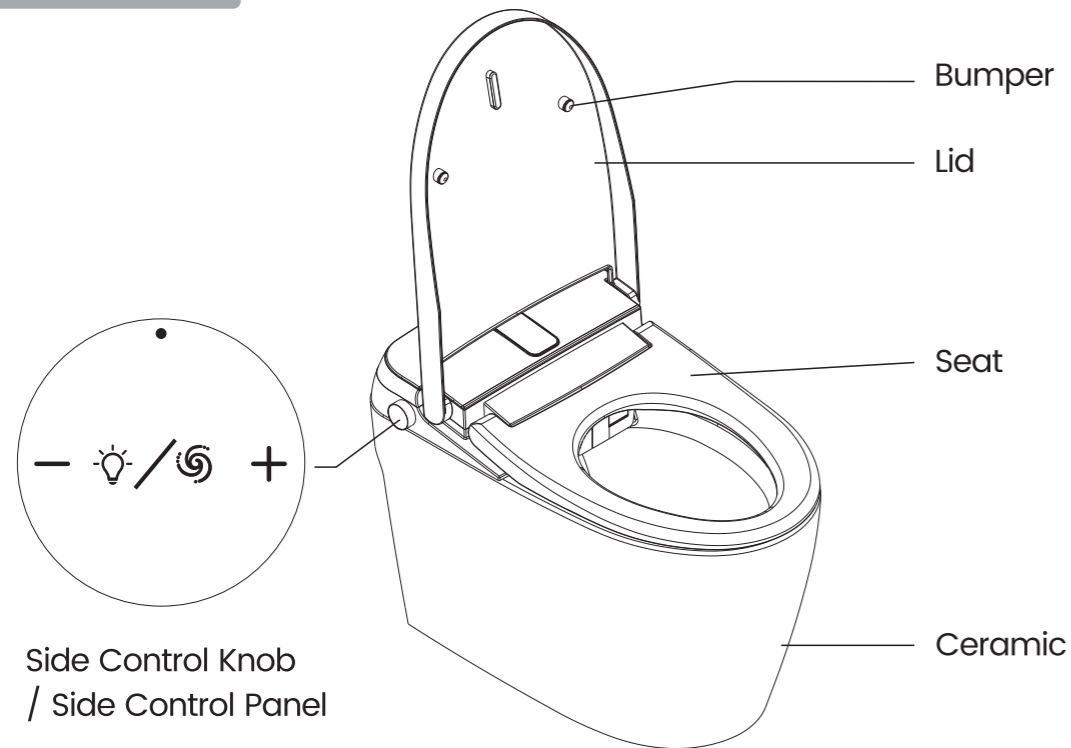

### Right side

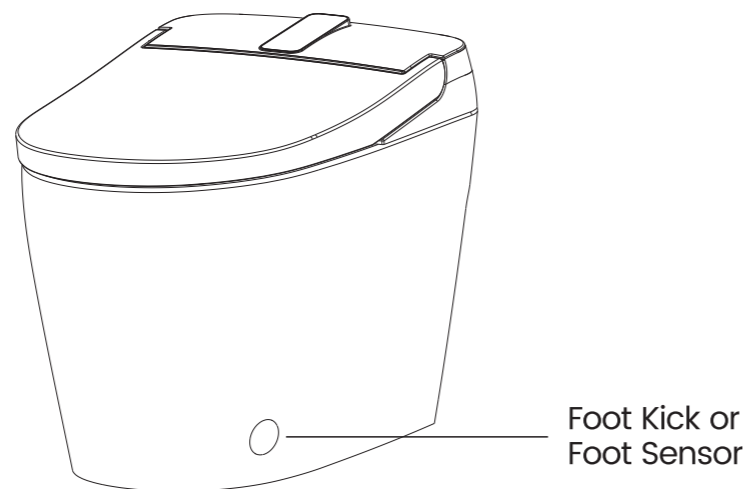

- The product drawing is for reference only, and we reserve the right to modify the appearance of the product. If the appearance of the product is changed, the actual product shall prevail.

## TOILET INSTALLATION

### Required Tools:



### Installation Diagram:

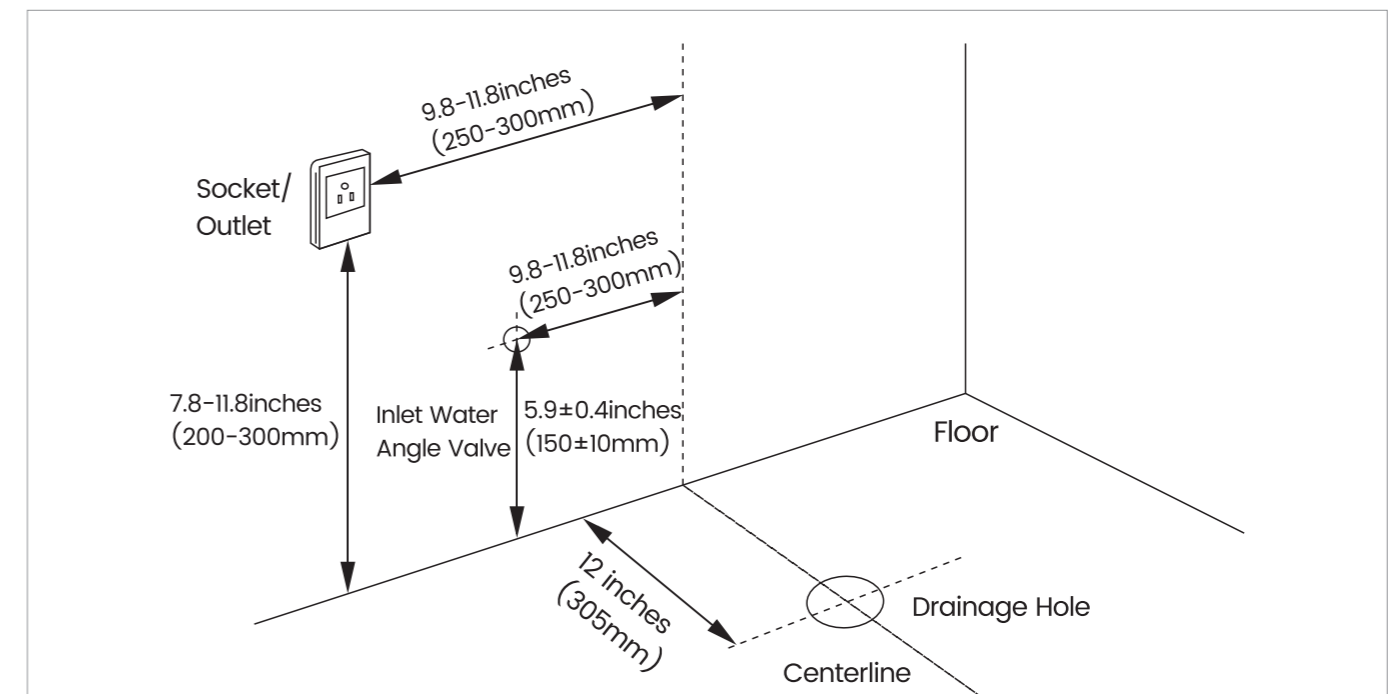

### ⚠ WARNING

#### Power Outlet Installation Instructions:

- Please ensure that the chosen power outlet has been properly grounded in accordance with the relevant protocols.
- The power cord should have a length of 1.5 meters. The location of the power outlet should be in close proximity to facilitate the installation and disassembly of this product, while also maintaining a safe distance from the bathtub area.
- It is strongly recommended to select a waterproof-type outlet. Avoid utilizing extension cords to connect the product. Failure to adhere to these instructions could potentially result in fire hazards or electrical shock.

# TOILET INSTALLATION

## Pre-Installation Precautions:

- **Water Pressure Test:** Ensure that water flow exceeds 1.32 gallons within 15 seconds.
- Before installation, drain water through the pipe for 1 minutes to avoid impurities remaining in the pipeline.

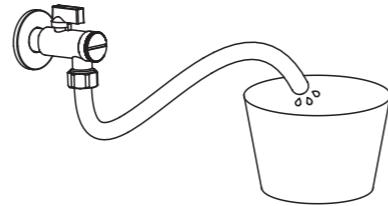

## Installation Steps:

### 1. For a newly installed toilet in the bathroom, a flange plate needs to be added. (Purchase flange plates by oneself)

- Place the flange plate into the drainage hole, aligning the arrow on the flange plate with the dashed line on the vertical wall.
- Use a marker to indicate the positions of the four installation holes on the flange plate.
- Use an electric drill to create four  $\varnothing 6\text{mm}$  installation holes on the flange plate. Insert four corresponding plastic anchors.
- Secure the flange plate in place using the provided four screws.

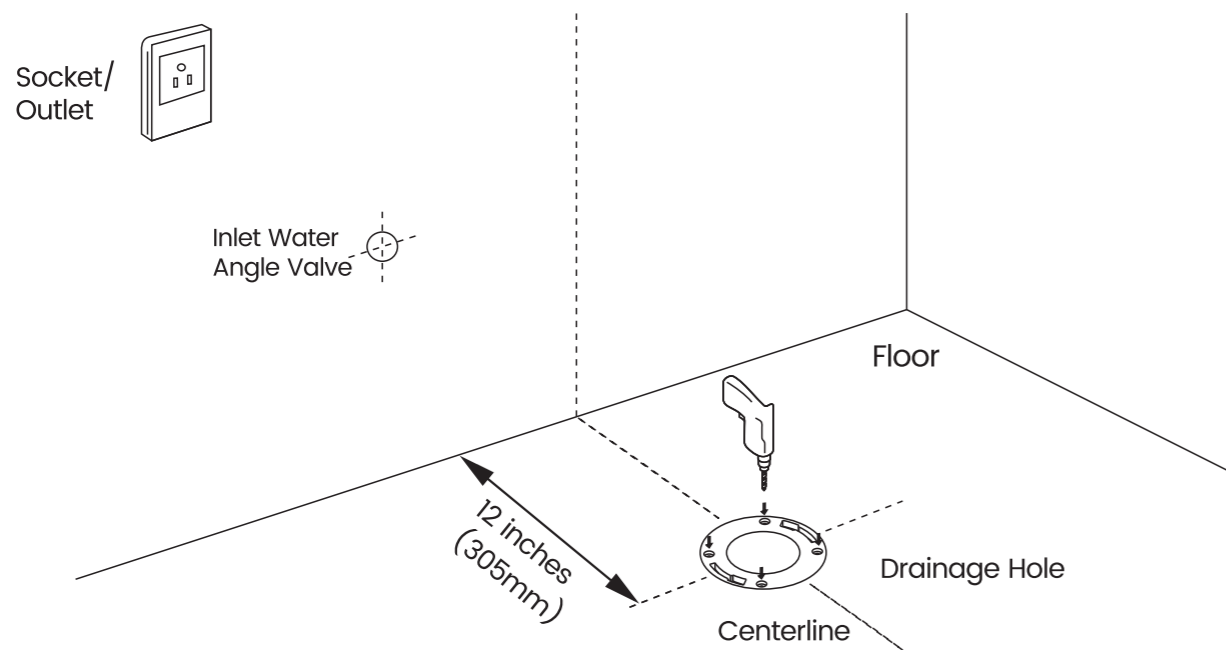

### 2. Insert the T-bolts into the flange. Then, place the plastic gasket.

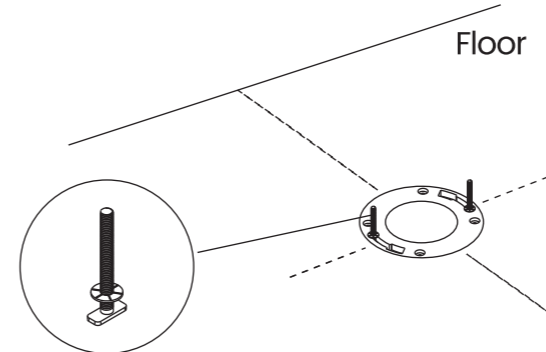

### 3. Lift the toilet seat from the toilet.

**Note:** When lifting the toilet seat, lift it carefully from the inside and avoid pulling it too forcefully.

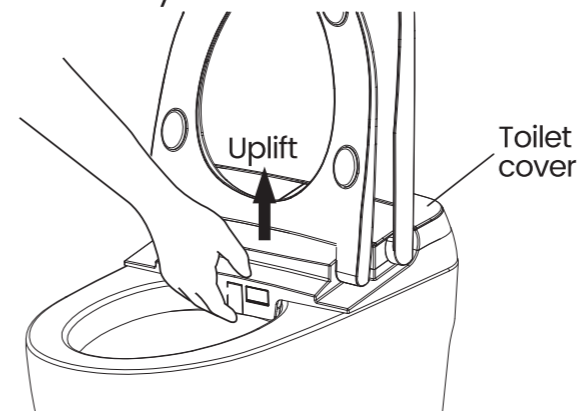

### 4. Place a flange ring under the toilet.

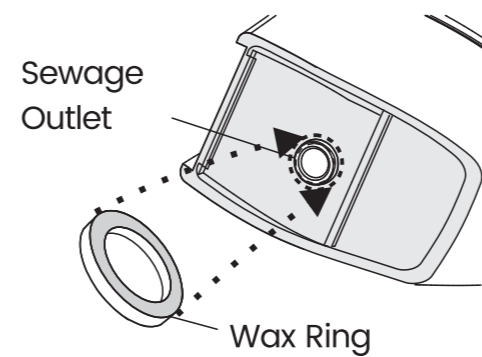

### 5. Insert the T-bolts into the ceramic lock screw holes, place flat washers on the T-bolts, and then tighten with nuts.

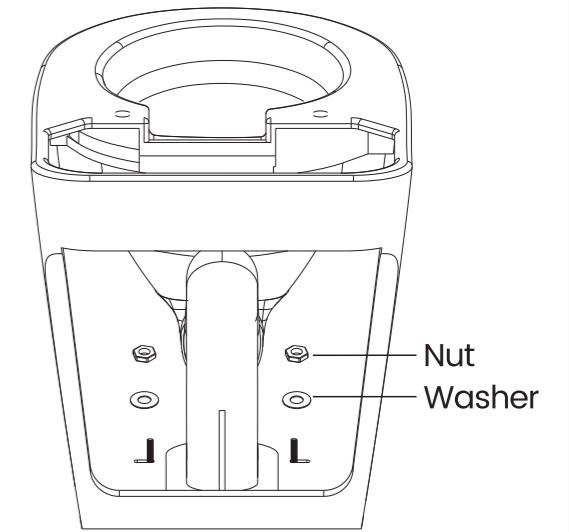

### 6. Installation of Battery box

Use supplied external battery box for flushing when there is out of power. Connect DC connector on the battery box to the wire cable from toilet. Place external battery box at the bottom of the toilet.

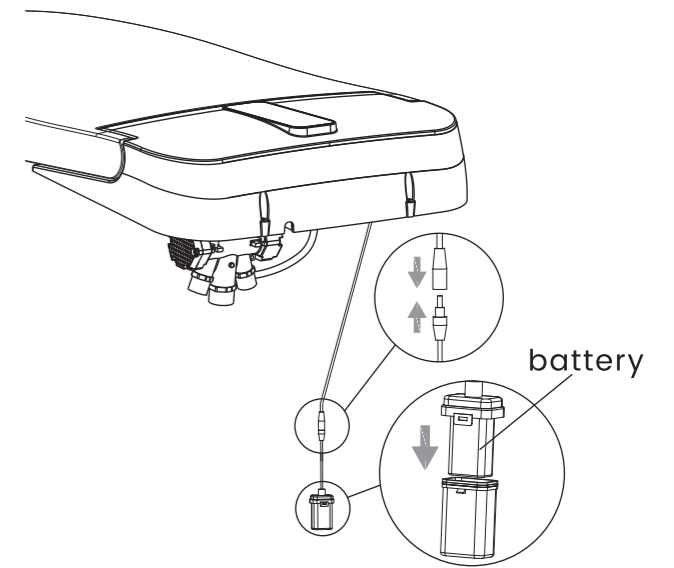

**Note:** Use 9V battery for external battery box.

# TOILET INSTALLATION

**7. Install the toilet seat onto the toilet body. Align the toilet seat's positioning holes with the ceramic body's positioning pins. Press the back part of the toilet seat firmly with both hands in a horizontal position, ensuring the positioning holes are securely fitted onto the ceramic pins.**

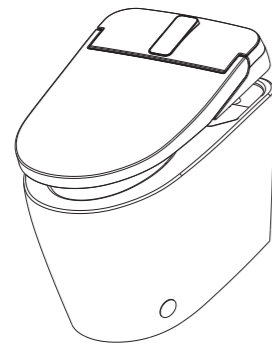

## 8. Install angle valve

### 8.1 Installation Method 1:

8.1.1 Insert the water-saving insert and flat gasket into the G1/2-G3/4 adapter.

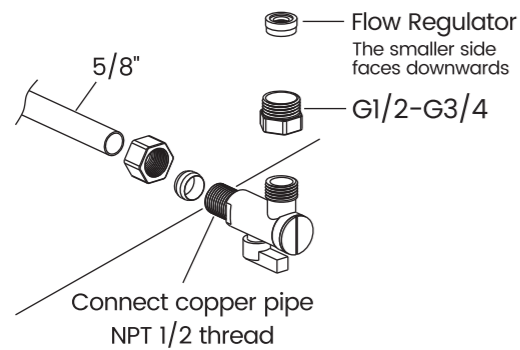

8.1.2 Screw the G1/2-G3/4 connector into the angle valve and connect the angle valve to the copper pipe.

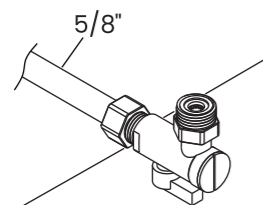

### 8.2 Installation Method 2:

8.2.1 Insert the water-saving insert and flat gasket into the G1/2-G3/4 adapter.

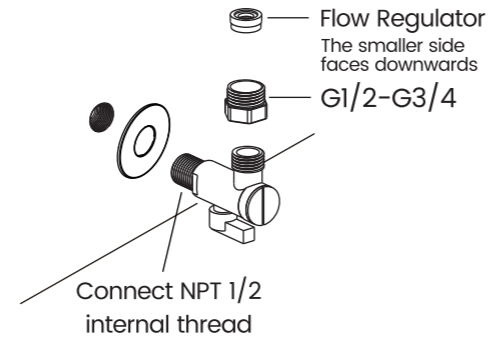

8.2.2 Screw the G1/2-G3/4 connector into the angle valve, and then screw the angle valve into the water inlet.

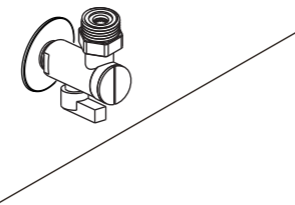

### 8.3 Installation Method 3:

8.3.1 Wrap sealing tape around the NPT 9/16 thread of the valve and screw the end of NPT 9/16 onto the valve.

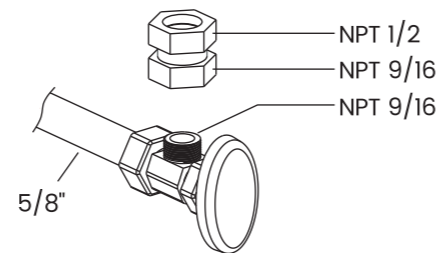

8.3.2 Remove the copper sleeve and nut from the NPT 1/2 valve.

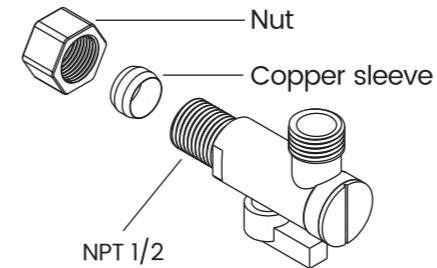

8.3.3 Wrap sealing tape around the NPT 1/2 thread of the valve, and then tighten the valve joint NPT 1/2 location.

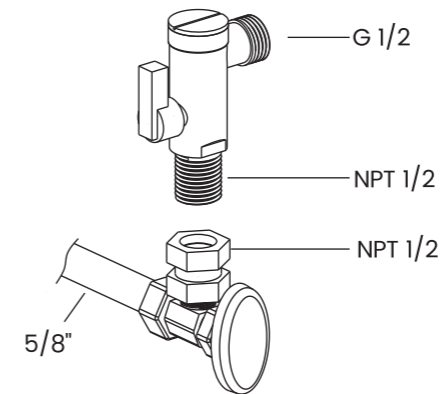

8.3.4 Twist the G 1/2-G3/4 variable diameter joint G 1/2 end onto the valve G 1/2. Then place the water-saving device into the variable diameter joint G3/4.

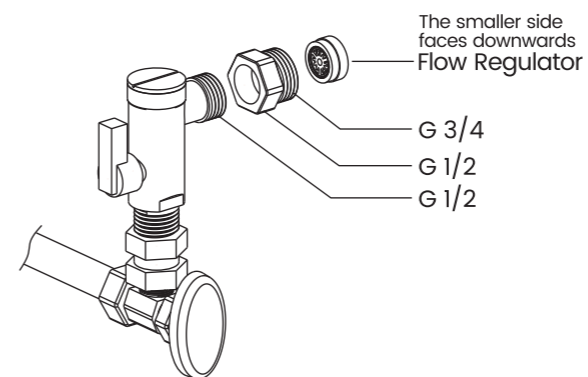

8.3.5 Connect the water inlet hose and open the valve.

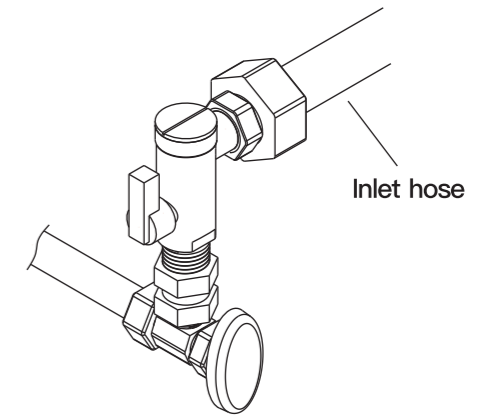

8.4 Apply a circle of anti-mold sealing silicone at the junction between the toilet and the floor. After the silicone sealant has solidified, plug in the power and slowly open the angle valve. Adjust the water pressure to be within 80 PSI and inspect the seals of all connection points.

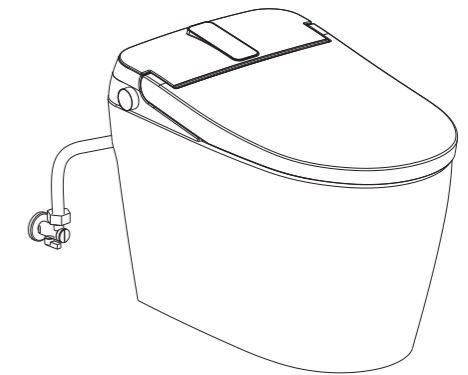

## BEFORE USING

### 1. Turn on the angle valve

- Check the threaded connection to ensure there are no leaks.
- Unscrew the angle valve counterclockwise to fully open it.

(Tips: When opening the angle valve for the first time, the handle may require more torque.)

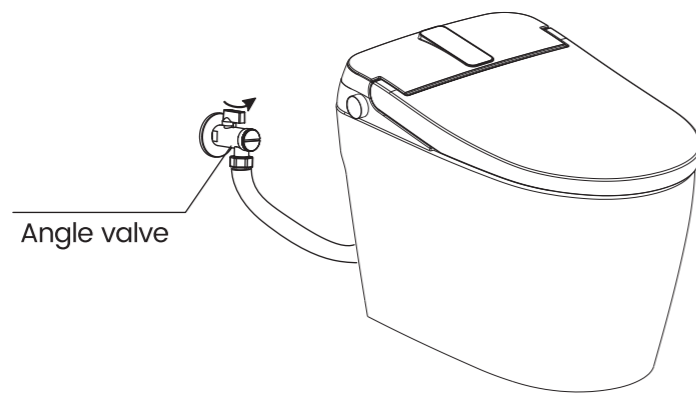

### 2. Power Connection

Insert the leakage protection plug into the power socket. Press the reset switch. The plug indicator lights up, indicating that the power is on.

#### Tips:

- Before usage, press the electric leakage test button. The reset switch should pop up, indicating that the leakage protection function is normal.
- Press the TEST button (then the RESET button) every month to ensure proper operation.

**Note:** Only applicable for models equipped with a leakage protection plug. Please refer to the actual product for details.

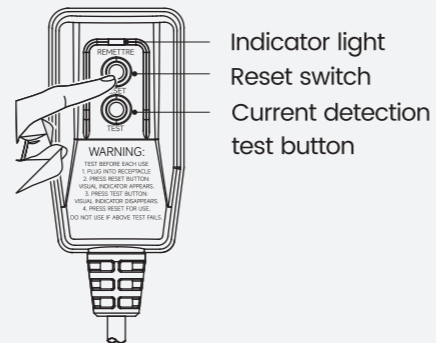

### 3. Self-inspection

- The main unit buzzer rings "beep".
- After another "beep" from the buzzer, self-inspection is complete.
- Proceed to normal function mode for regular usage.

## FUNCTION DESCRIPTION

### Microwave Flip Cover

(This feature is unique to the automatic flip toilet)

- Microwave flip cover Open and close the seat cover by identifying the proximity/presence/ departure of the human body;
- When the human body is approximately 30-60cm away from the toilet, the cover will automatically open.
- When the cover is opened, it will automatically close 30 seconds after the human body departs.
- When the seat is lifted, both the seat and the toilet cover will automatically close and initiate a water flush upon the departure of the human body.
- If the flushing function has already been activated during use, no additional flushing will occur after the cover is closed.

### Foot Kick Flip the Cover And the Seat

(This feature is unique to the automatic flip toilet)

- When the cover is closed, kick the foot kick, it will automatically open the cover;
- When the cover is opened/the seat is closed, kick the foot kick, it will automatically open the seat;
- When the seat is opened, kick the foot kick, it will automatically close the cover, the seat and then flush.

### Automatic Flush After Leave

When the human body is seated for at least five seconds, it will automatically flush after leaving the seat.

### Power Outage Flushing

The toilet can be equipped with a backup battery. In the event of a power outage, short press the knob to activate the flushing function.

### Energy Saving Mode

When the intelligent toilet is not used for 1 hour, it will automatically enter energy-saving mode, and the seat temperature will automatically adjust to 91°F, entering a low-temperature setting. Upon being seated, it will reheat to the preset temperature.

## FUNCTION DESCRIPTION

### Side Buttons:

There are 2 buttons on the side: **[Flush]**, **[Seat temperature adjustment]**.

- Short press "Flush" to start flushing.
- Short press "Seat Temperature" to adjust seat temperature.
- Long press "Seat Temperature" for 5 seconds to open/close night light.
- Long press "Flush" for 5 seconds to open/close the toilet.

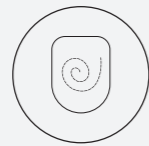

Flush



Seat temperature adjustment

\*The above is for reference only. Please select the corresponding function description based on the actual toilet model.

### Control Knob:

There are 4 functions of the side control knob: **[Flush]**, **[Increasing seat temperature]**, **[Decreasing seat temperature]**, **[Stop]**.

- Rotate the knob clockwise to increase the seat temperature.
- Rotate the knob counterclockwise to decrease the seat temperature.
- Press the knob to flush.
- Press and hold the knob for 3 seconds to power on/off the toilet.
- Rotate the knob clockwise for 3 seconds to turn on/off the night light.

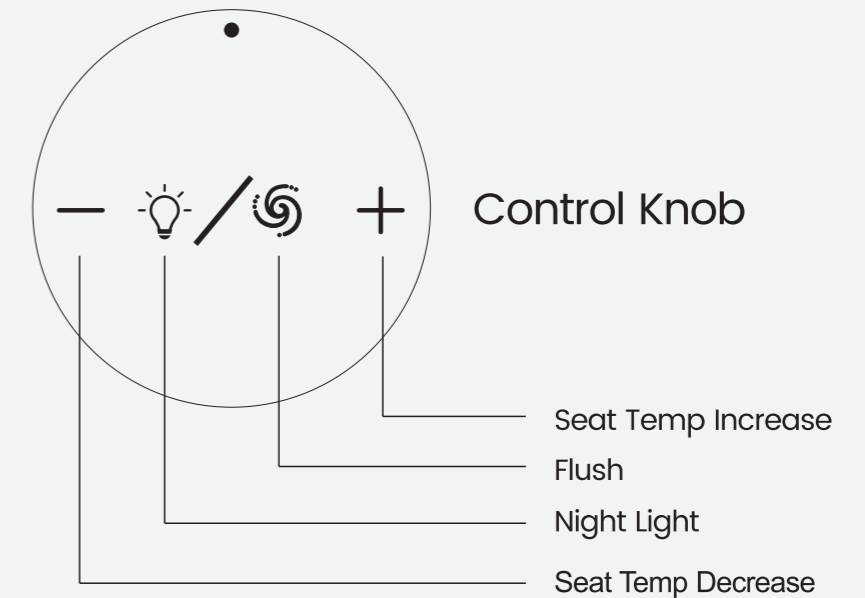

\*The above is for reference only. Please select the corresponding function description based on the actual toilet model.

## DAILY MAINTENANCE

### Main unit care and maintenance

1. Shut off power supply before doing maintenance.

2. Wipe the stain with a soft damp cloth.

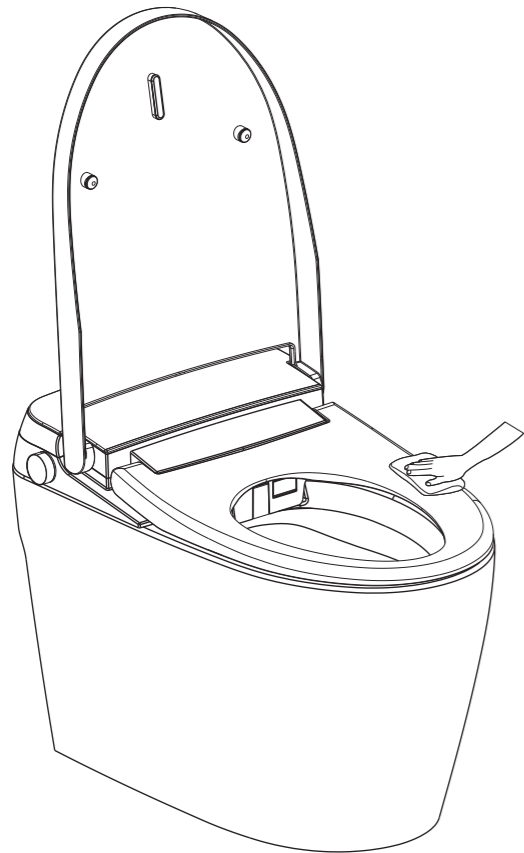

3. After cleaning, re-connect the toilet with the power supply.

### Maintenance of filter net

Maintenance is required when the system is under normal water pressure but experiencing poor flush performance.

1. Turn off power and the angle valve.

2. Unscrew angle valve nut.

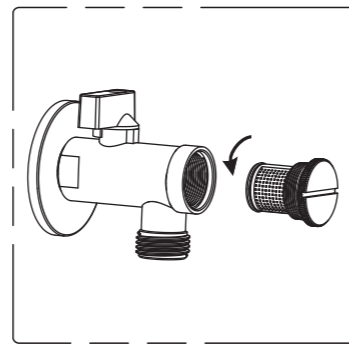

3. Use a brush to clean filter net.

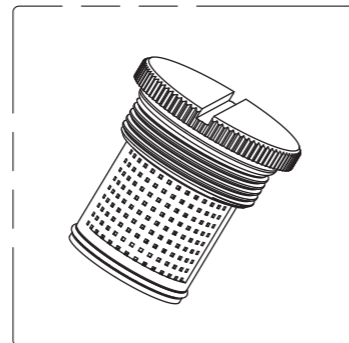

4. Reinstall filter net.

5. Turn on the angle valve and connect power, then it can work normally after self inspection.

## TROUBLESHOOTING GUIDE

Problem	Cause	Solution
Low seat temperature	The seat temperature is set on normal temperature level	Reset the seat temperature
Toilet leaking	Close the angle valve, inspect all water pipes, and contact a professional.	
 <b>Caution</b>	If the problems cannot be resolved using the methods above, please shut off the power and contact service providers for maintenance.	
	If the leakage circuit breaker frequently trips, indicating electrical leakage, shut off the power and contact the service provider for maintenance.	

## Warranty Instructions

### UNIKOO® One-Year Limited Warranty

At UNIKOO®, we take pride in the quality and durability of our products. Every UNIKOO toilet is manufactured with high-quality materials and workmanship to ensure lasting performance.

#### Warranty Coverage

UNIKOO warrants to the **original purchaser** that its toilets will be free from defects in materials and workmanship during **normal residential use for one (1) year from the date of purchase**. During this period, UNIKOO will, at its option, provide replacement parts or repair the product free of charge.

This warranty applies only to UNIKOO toilets purchased from an authorized UNIKOO retailer or distributor and properly installed in accordance with installation instructions. Proof of purchase (sales receipt or invoice) is required for all warranty claims.

#### Warranty Exclusions

This warranty does **not** cover:

1. Damage caused by improper installation, misuse, abuse, negligence, accident, or alteration.
2. Damage caused by self-repair attempts or service performed by unauthorized repair personnel.
3. Damage due to improper maintenance, including use of harsh or abrasive cleaners or chemicals.
4. Normal wear and tear, such as surface scratches, fading, or gloss reduction.
5. Damage caused by acts of nature (fire, flood, earthquake, etc.) or external factors (power surges, water pressure above local code limits, etc.).
6. Damage from transportation, handling, or storage after the product leaves UNIKOO's facilities.
7. Any incidental or consequential damages, including labor, removal, reinstallation, or property damage.

#### Limitation of Liability

This limited warranty is the **exclusive remedy** for the original purchaser. UNIKOO shall not be liable for incidental, consequential, or special damages of any kind, including but not limited to labor costs, installation, removal, transportation, lost profits, or property damage. In no event will UNIKOO's responsibility exceed the purchase price of the product.

Return shipping costs are **not covered** under this warranty.

Some states do not allow the exclusion or limitation of incidental or consequential damages, so these limitations may not apply to you. This warranty gives you specific legal rights, and you may also have other rights which vary from state to state.

#### Warranty Service

To obtain warranty service:

1. Stop using the product immediately if a malfunction occurs.
2. Contact UNIKOO's nationwide after-sales service team by phone at **888-404-5533** or by email at **info@unikoo.com**.
3. Provide proof of purchase and the product's serial number when making a claim.
4. UNIKOO may request photos or inspection to verify the issue before approving service.

**Important:** Warranty claims may be denied if installation was not performed according to UNIKOO's instructions or if the product has been serviced by an unauthorized provider.