

Assembly Guide

Contents

English ————— 01-06

German ————— 07-12

French ————— 13-18

Components

01 x2

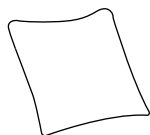

02 x2

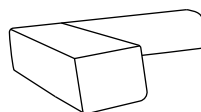

03 x2

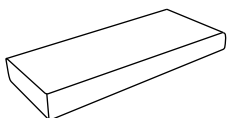

04 x2

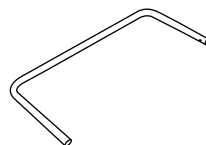

05 x2

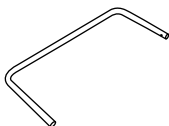

06 x2



07 x2



08 x4

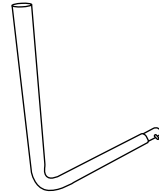

09 x4

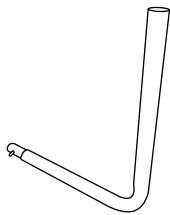

Installation

The installation steps are as follows:

Step 1 Wait 72 hours for rebound

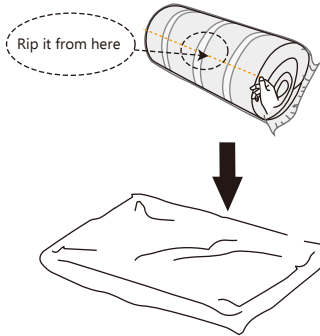

Step 2

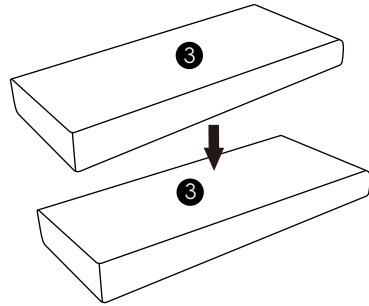

Step 3

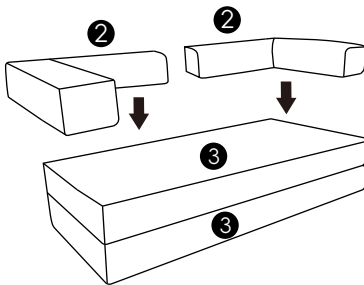

Step 4

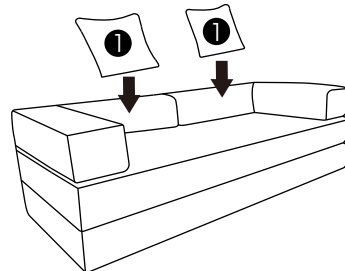

Step 5

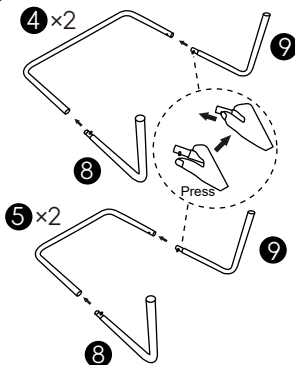

Step 6 Insert parts (F) and (G) into the marked position.

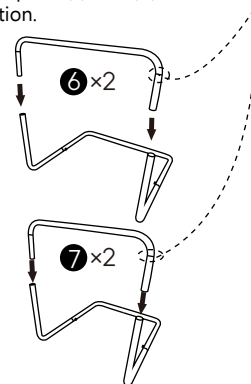

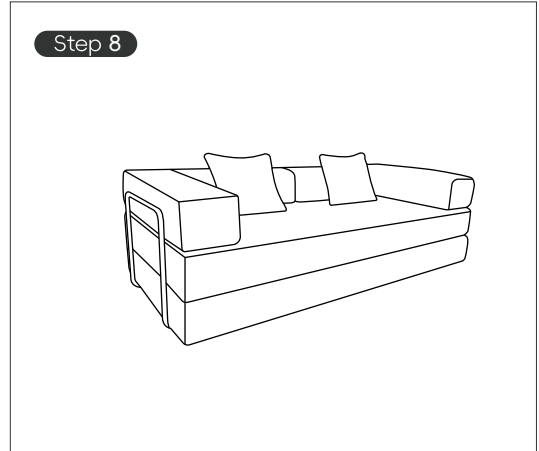
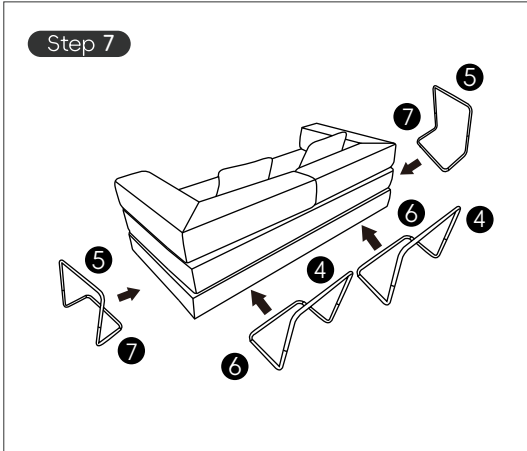

All Done!

Go ahead, try it out. You may experience what we call an "ahhh" sensation.

That's completely normal. You're now well equipped for whatever the workday throws at you.

Now, don't be shy. Show us how us how it looks!

Sofa Care

To keep your sofa looking great and extend its lifespan:

- Vacuum regularly with a soft brush attachment to remove dust and debris.
- Clean spills immediately with a clean cloth—do not rub forcefully.
- Wipe clean with a damp cloth. Use only mild fabric-safe cleaners. Test first on a hidden area.
- Avoid direct sunlight to prevent fading.
- Realign modules regularly to prevent shifting or gaps.
- Fluff and rotate cushions to maintain shape and comfort.
- Keep sharp objects away from the surface of the sofa.

Cushion Cover Care

- Wipe clean with a damp cloth.
- Do not wash.
- Do not bleach.
- Do not tumble dry.
- Do not iron.
- Do not dry clean.

Komponenten

01 x2

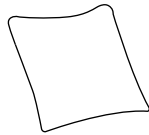

02 x2

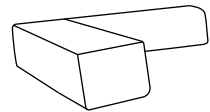

03 x2

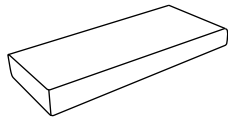

04 x2

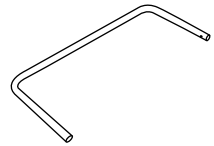

05 x2

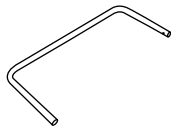

06 x2



07 x2



08 x4

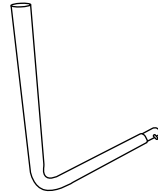

09 x4

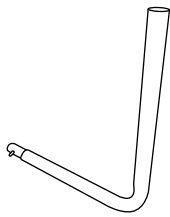

Montageanleitung

Die Installationschritte sind wie folgt:

Schritt 1 72 Stunden für die Rückformung warten.

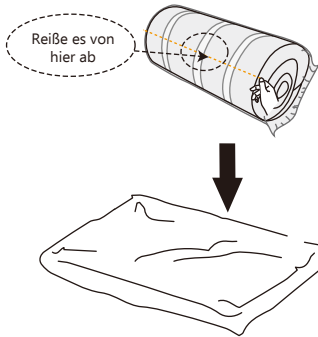

Schritt 2

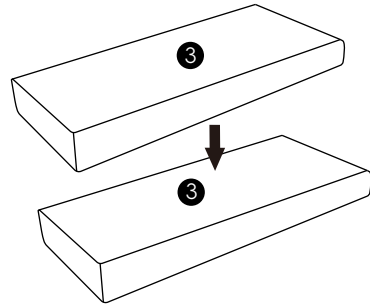

Schritt 3

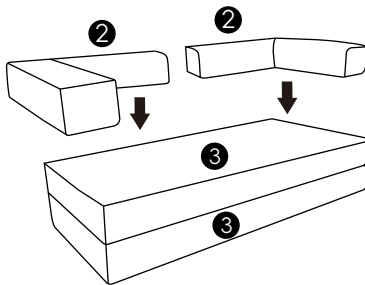

Schritt 4

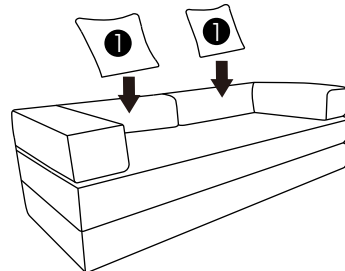

Schritt 5

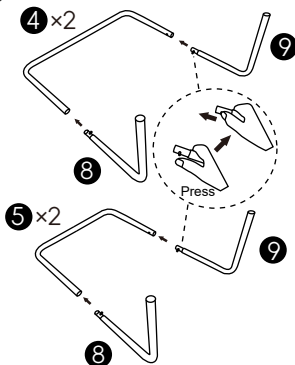

Schritt 6 Teile (F) und (G) an der markierten Stelle einsetzen.

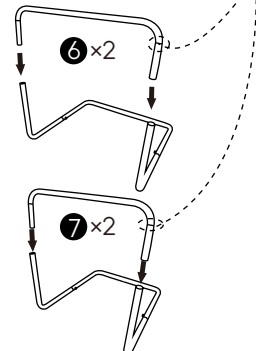

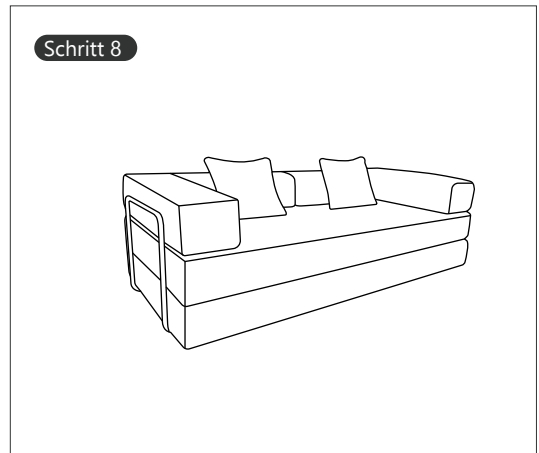
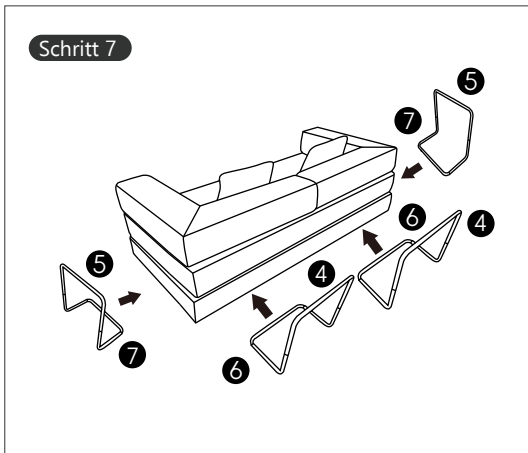

eschafft!

Probieren Sie es aus, Sie werden vielleicht ein „ahhh“ - Gefühl verspüren.

Das ist völlig normal. Sie sind jetzt gut gerüstet für alles, was der Arbeitstag Ihnen abverlangt.

Seien Sie nicht schüchtern, lassen Sie uns sehen, wie es aussieht!

Sofapflege

To keep your sofa looking great and extend its lifespan:

- Vacuum regularly with a soft brush attachment to remove dust and debris.
- Clean spills immediately with a clean cloth—do not rub forcefully.
- Wipe clean with a damp cloth. Use only mild fabric-safe cleaners. Test first on a hidden area.
- Avoid direct sunlight to prevent fading.
- Realign modules regularly to prevent shifting or gaps.
- Fluff and rotate cushions to maintain shape and comfort.
- Keep sharp objects away from the surface of the sofa.

Pflege der Kissenbezüge

- Mit einem feuchten Tuch abwischen. Nicht waschen.
- Nicht waschen.
- Nicht bleichen.
- Nicht im Trockner trocknen.
- Nicht bügeln.
- Nicht chemisch reinigen.

Com osants

01 x2

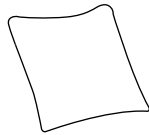

02 x2

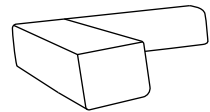

03 x2

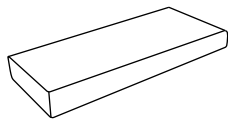

04 x2

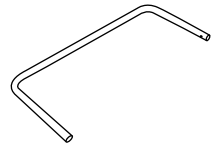

05 x2

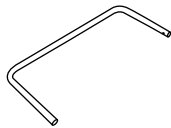

06 x2



07 x2



08 x4

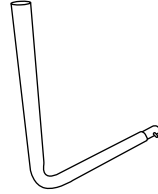

09 x4

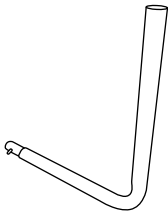

Montageanleitung

Les étapes d'installation sont les suivantes :

Étape 1 Attendre 72 heures pour le rebond.

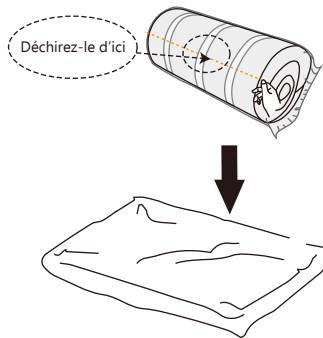

Étape 2

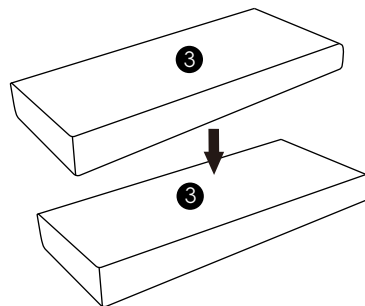

Étape 3

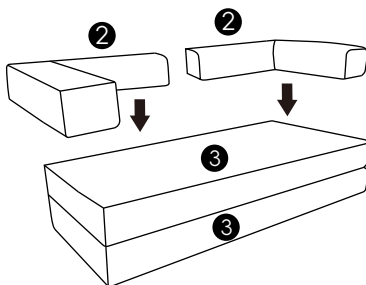

Étape 4

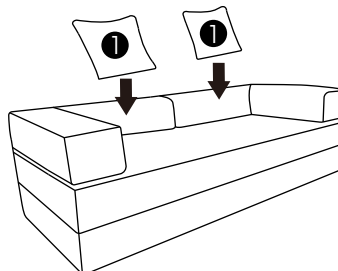

Étape 5

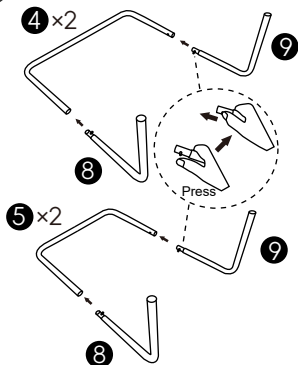

Étape 6 Insérer les pièces (F) et (G) dans l'emplacement marqué

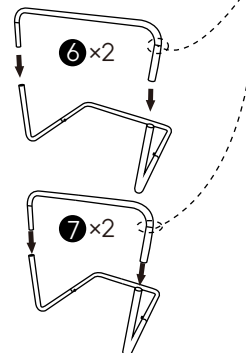

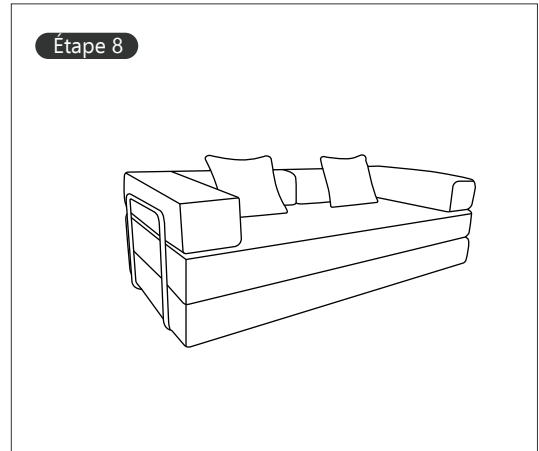
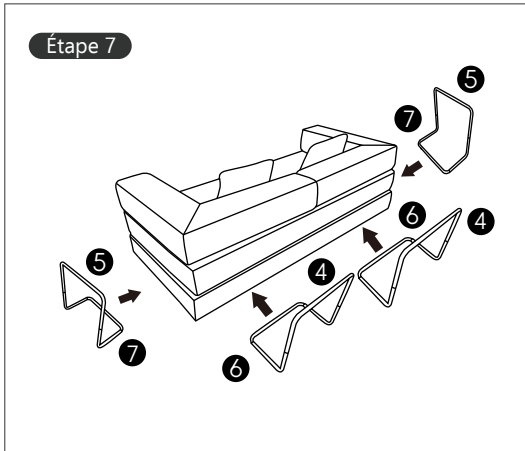

C'est terminé !

Allez-y, essayez-le. Vous pourriez ressentir ce que nous appelons une sensation d'"ahhh".

C'est tout à fait normal. Vous êtes maintenant parfaitement équipé pour affronter n'importe quoi que la journée de travail puisse vous proposer.

Seien Sie nicht schüchtern, lassen Sie uns sehen, wie es aussieht!

Soins cana é

To keep your sofa looking great and extend its lifespan:

- Vacuum regularly with a soft brush attachment to remove dust and debris.
- Clean spills immediately with a clean cloth—do not rub forcefully.
- Wipe clean with a damp cloth. Use only mild fabric-safe cleaners. Test first on a hidden area.
- Avoid direct sunlight to prevent fading.
- Realign modules regularly to prevent shifting or gaps.
- Fluff and rotate cushions to maintain shape and comfort.
- Keep sharp objects away from the surface of the sofa.

Entretien de la housse de coussin

- Essuyer avec un chiffon humide. Ne pas laver.
- Ne pas laver.
- Ne pas utiliser d'eau de Javel.
- Ne pas sécher au sèche-linge.
- Ne pas repasser.
- Ne pas nettoyer à sec.