

STORAGE CABINET

Assembly Instructions - Please keep for future reference

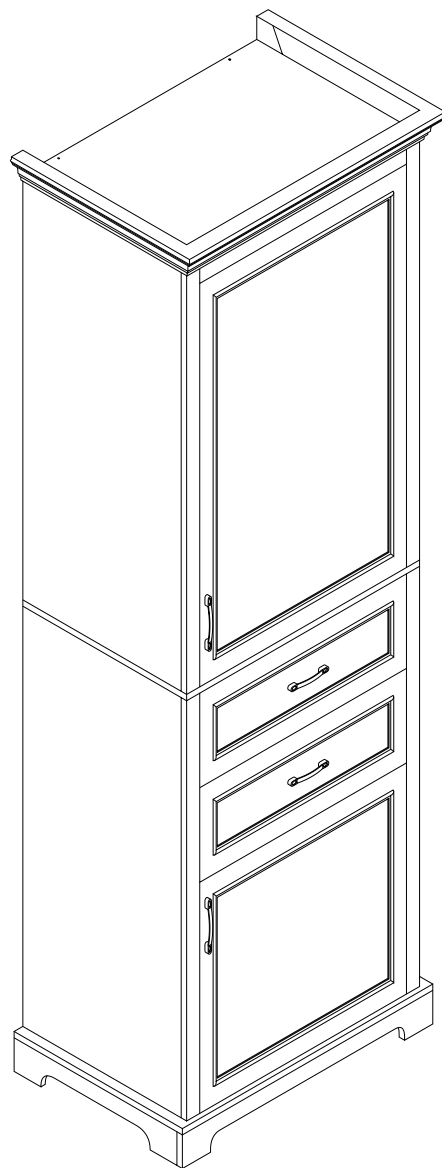

Important – Please read these instructions fully before starting assembly



Safety and Care Advice

Important – Please read these instructions fully before starting assembly

- Check you have all the components and tools listed on the following pages.
- Remove all fittings from the plastic bags and separate them into their groups.
- Keep children and animals away from the work area, small parts could choke if swallowed.
- Make sure you have enough space to layout the parts before starting.

- During assembly do not stand or put weight on the product, this could cause damage.
- Assemble the item as close to its final position (in the same room) as possible.
- Assemble on a soft level surface to avoid damaging the unit or your floor.
- Parts of the assembly will be easier with 2 people.



power drill is set on a low torque setting.

- To reduce the likelihood of damaging your product please ensure that your

Care and maintenance

• Only clean using a damp cloth and mild detergent, do not use bleach or abrasive cleaners.

• From time to time check that there are no loose screws on this unit.

• This product should not be discarded with household waste. Take to your local authority waste disposal centre.

Handy Hints

• Assemble all parts and bolts loosely during assembly, only once the product is complete should you fully tighten the bolts

• Regularly check and ensure That all bolts and fittings are tightened properly.

WARNING
In order to help prevent overturning – please follow these instructions









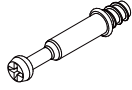

To help prevent product toppling over please follow the below steps:-

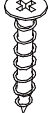
- Use the anti tip stop or wall fixing method provided (if applicable)
- Do not allow children to climb or hang on the furniture
- Do not open more than one drawer at a time
- Do not place heavy items in the top drawers
- Do not place heavy items on top of the furniture, unless the furniture has been designed for this purpose

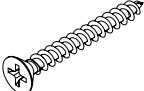
Components - Fittings

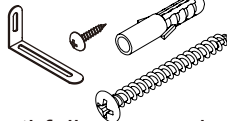
Please check you have all the panels listed below

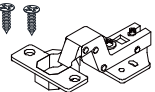
Note: The quantities below are the correct amount to complete the assembly. In some cases, more fittings may be supplied than required.

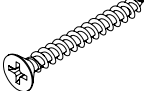
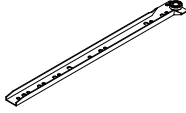
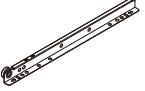
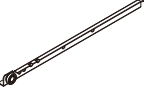
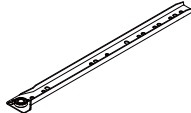
<p>(A)</p>  <p>Cam Bolt x 48</p>	<p>(B)</p>  <p>6*30mm Dowel x 53</p>	<p>(C)</p>  <p>Cam lock x 48</p>	<p>(D)</p>  <p>4*25mm Screw x 4</p>
<p>(E)</p>  <p>6*50mm Dowel x 4</p>	<p>(F)</p>  <p>4*40mm Screw x 50</p>	<p>(G)</p>  <p>4*20mm Handle x 2SET</p>	<p>(H)</p>  <p>3*12mm Screw x 16</p>
<p>(I)</p>  <p>Anti-fall accessories x2</p>	<p>(J)</p>  <p>Shelf support pin x 4</p>	<p>(K)</p>  <p>4*14mm Straight bend hinge x 4set</p>	<p>(L)</p>  <p>4*10mm Handle x 2SET</p>
<p>(M)</p>  <p>4*35mm Screw x 4</p>	<p>(CR)</p>  <p>300mm runner x 2</p>	<p>(DR)</p>  <p>300mm runner x 2</p>	<p>(DL)</p>  <p>300mm runner x 2</p>
<p>(CL)</p>  <p>300mm runner x 2</p>			

Using Camlocks

Step 1

Connect the male camlock as directed in the assembly instructions using a screwdriver.

1

DO NOT OVER TIGHTEN.
NE PAS SERRER EXCESSIVEMENT.

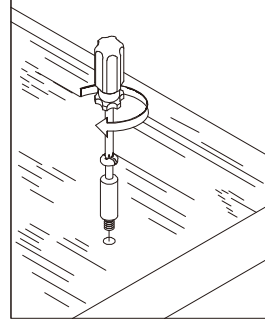

Step 2

Push the male camlock into the entry hole.

2

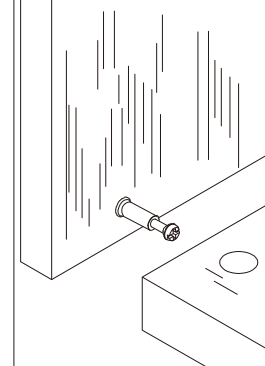

Step 3

Insert the female camlock as shown in the instruction.

Note : ensure that the arrow on the top of the camlock points towards the entry hole for the male camlock.

3

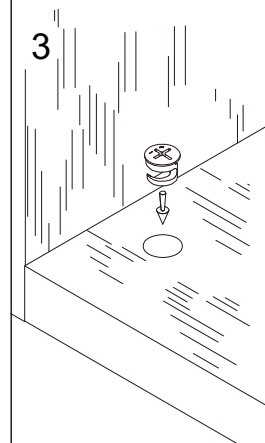

Step 4

Turn the female camlock clockwise with a screwdriver.

You should feel a click when the camlock is locked in place.

The joint is now secure.



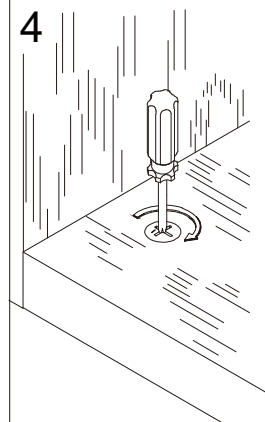



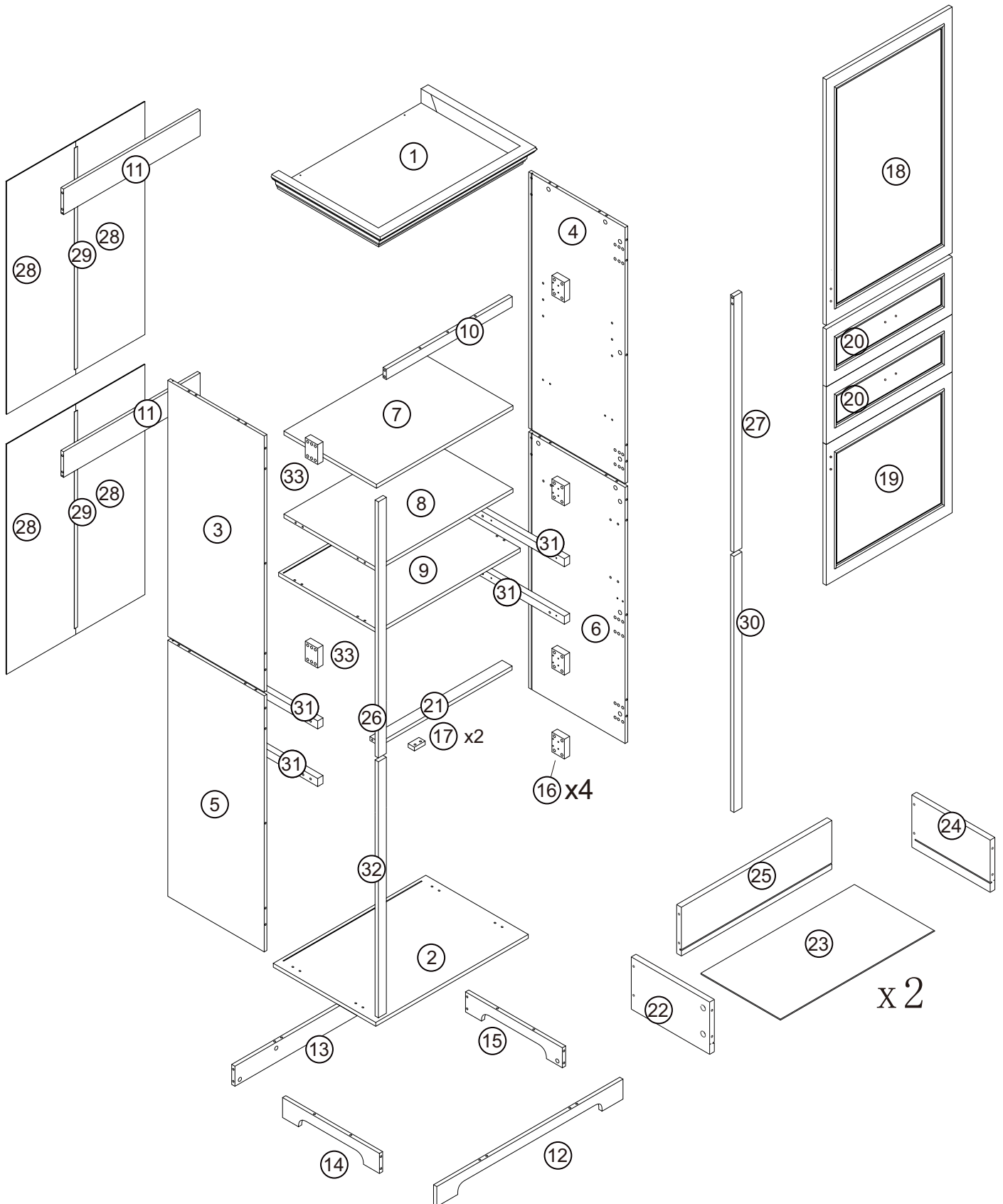

4

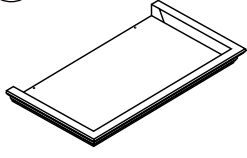
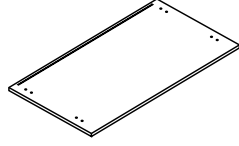

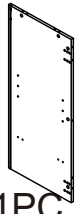
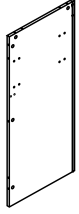

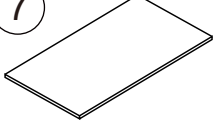
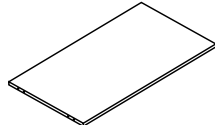
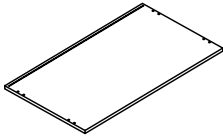
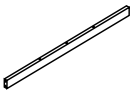
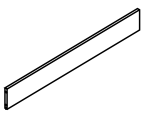
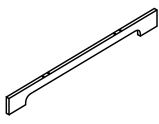
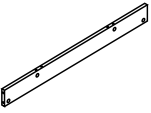



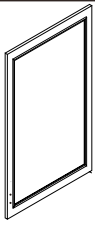
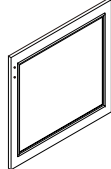
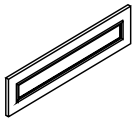
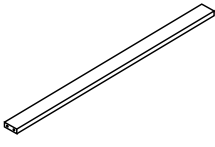

Assembly Instructions

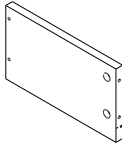
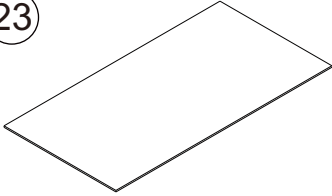
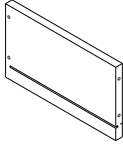
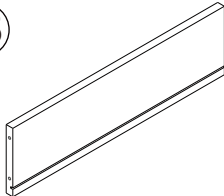

Assembly Instructions

<p>1</p>  <p>1PC</p>	<p>2</p>  <p>1PC</p>	<p>3</p>  <p>1PC</p>
<p>4</p>  <p>1PC</p>	<p>5</p>  <p>1PC</p>	<p>6</p>  <p>1PC</p>
<p>7</p>  <p>1PC</p>	<p>8</p>  <p>1PC</p>	<p>9</p>  <p>1PC</p>
<p>10</p>  <p>1PC</p>	<p>11</p>  <p>2PC</p>	<p>12</p>  <p>1PC</p>
<p>13</p>  <p>1PC</p>	<p>14</p>  <p>1PC</p>	<p>15</p>  <p>1PC</p>
<p>16</p>  <p>4PC</p>	<p>17</p>  <p>2PC</p>	<p>18</p>  <p>1PC</p>
<p>19</p>  <p>1PC</p>	<p>20</p>  <p>2PC</p>	<p>21</p>  <p>1PC</p>

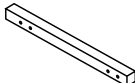
Assembly Instructions

<p>22</p>  <p>2PC</p>	<p>23</p>  <p>2PC</p>	<p>24</p>  <p>2PC</p>
<p>25</p>  <p>2PC</p>	<p>26</p>  <p>1PC</p>	<p>27</p>  <p>1PC</p>
<p>28</p>  <p>4PC</p>	<p>29</p>  <p>2PC</p>	<p>30</p>  <p>1PC</p>
<p>31</p>  <p>4PC</p>	<p>32</p>  <p>1PC</p>	<p>33</p>  <p>2PC</p>

Assembly Instructions

Step 1

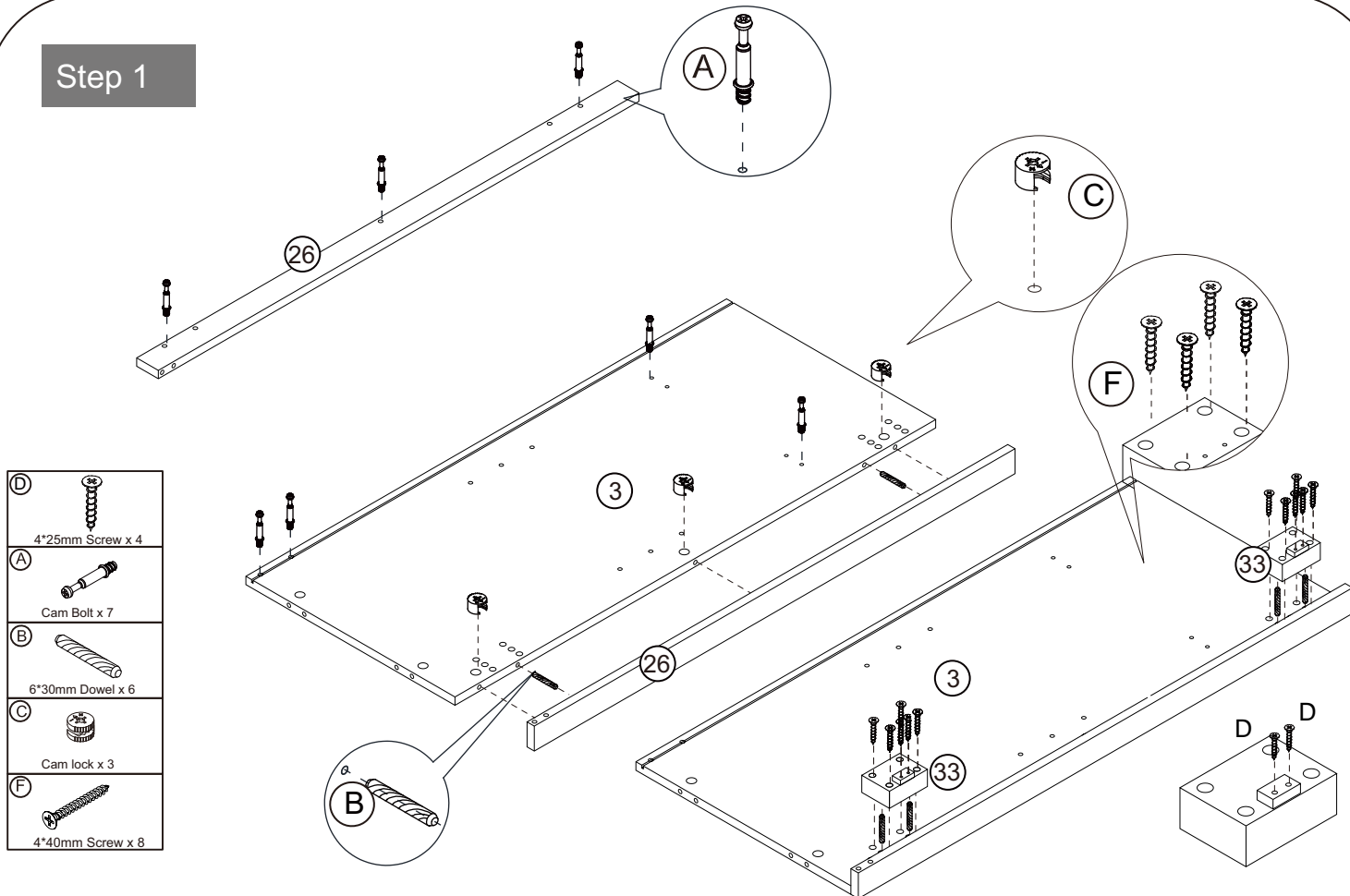

Step 2

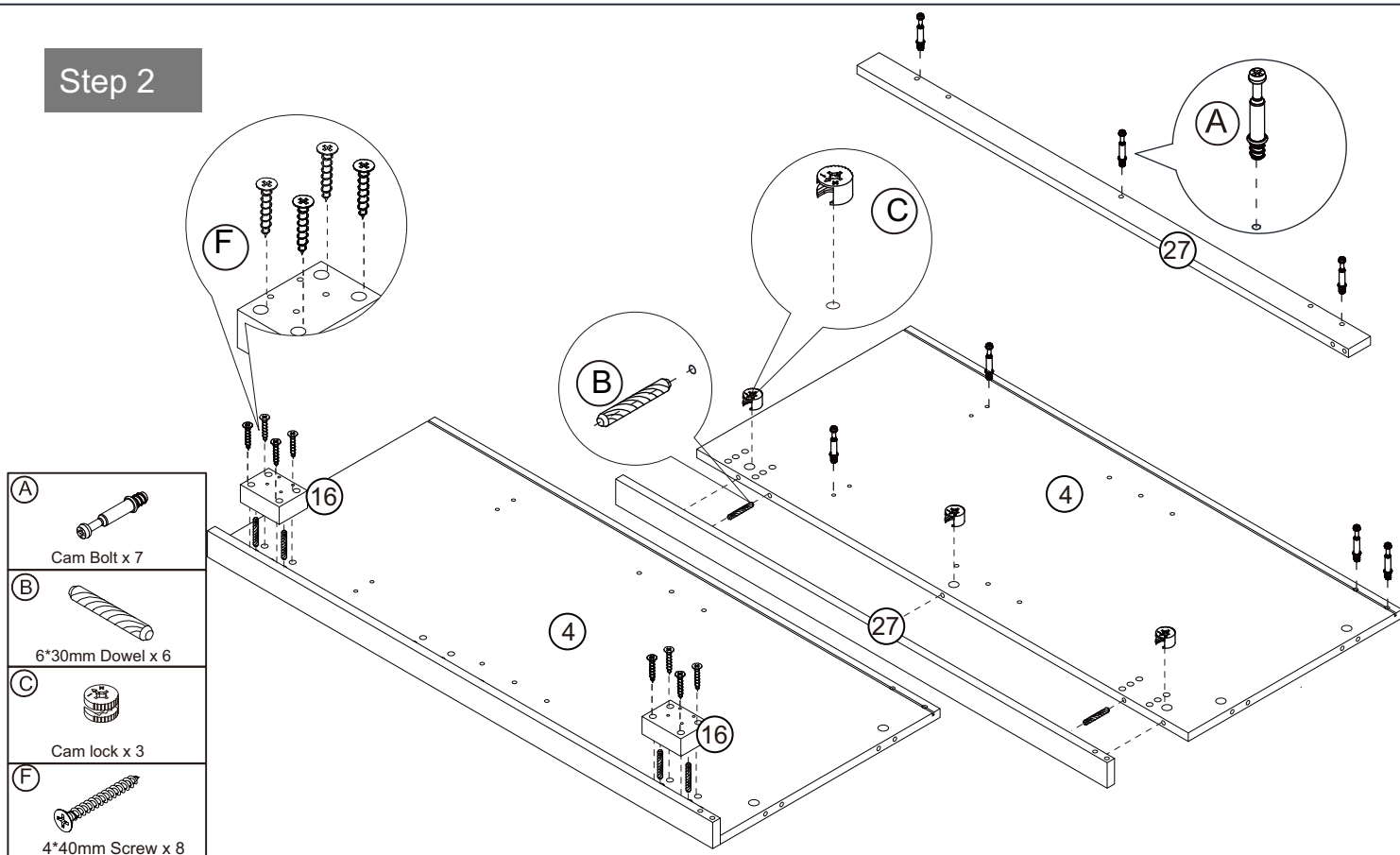

Assembly Instructions

Step 3

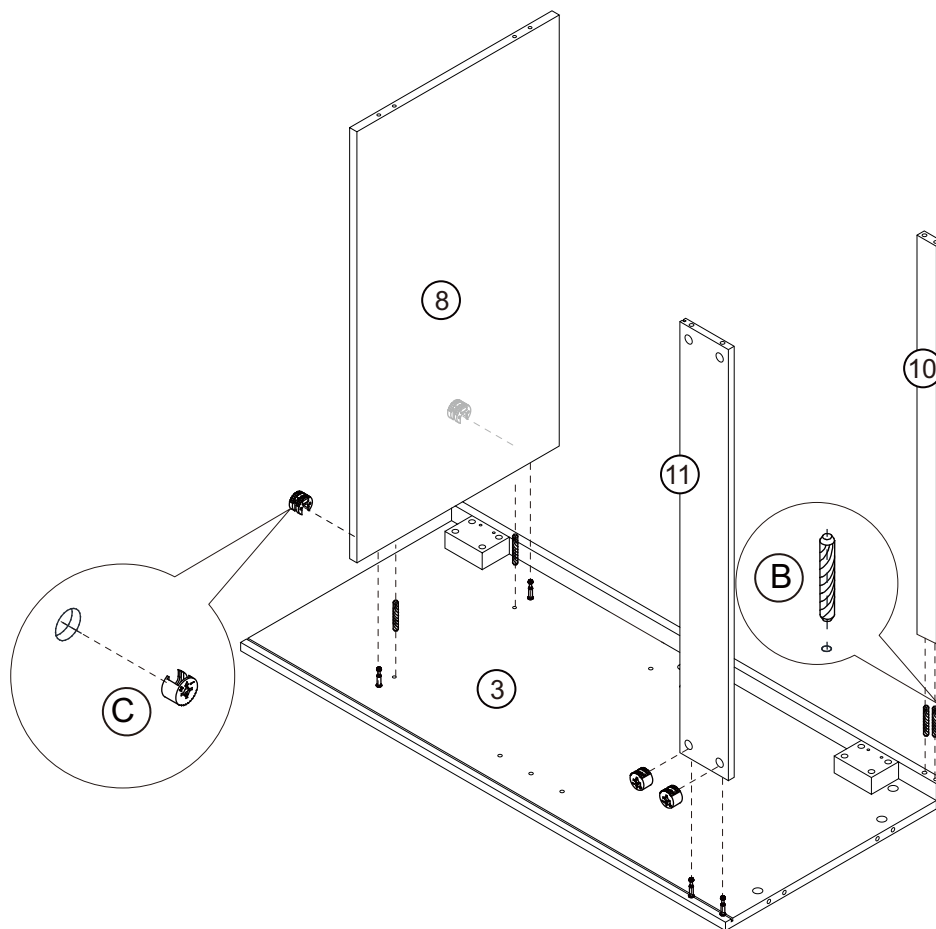
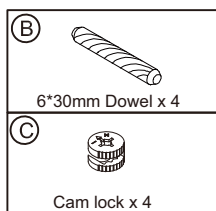



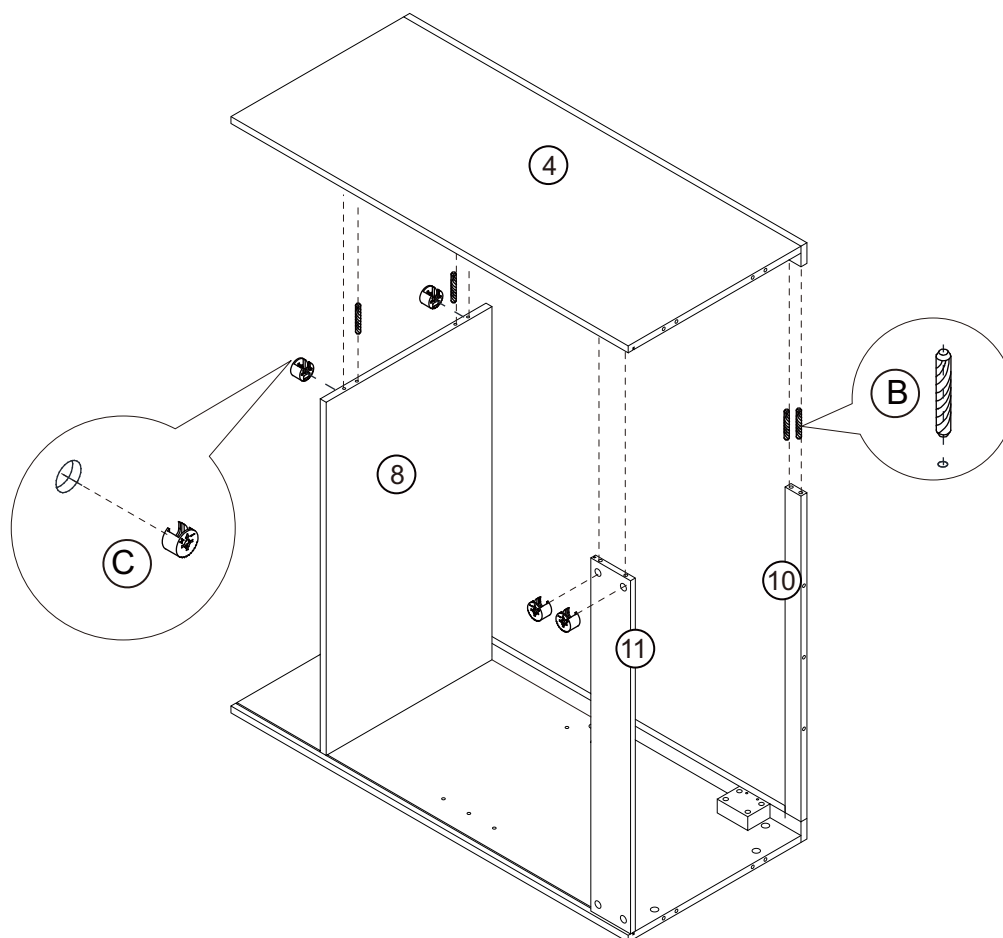
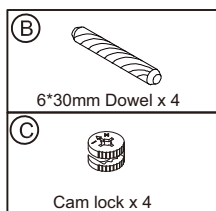

Step 4

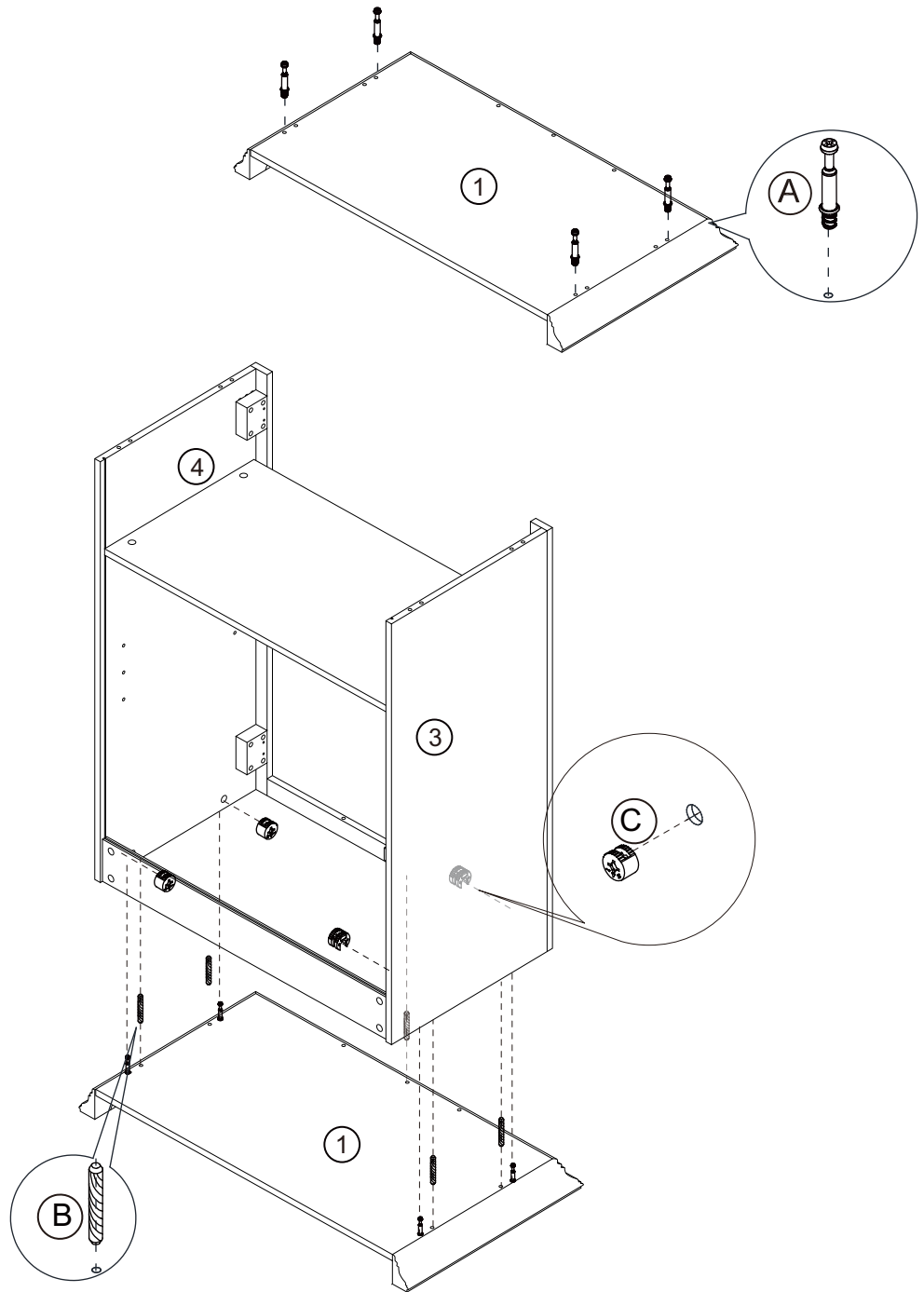

Assembly Instructions

Step 5



(A)	
Cam Bolt x4	
(B)	
6*30mm Dowel x 5	
(C)	
Cam lock x 4	

Assembly Instructions

Step 6

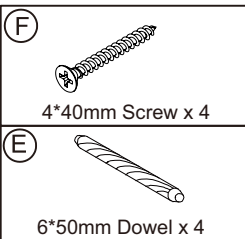
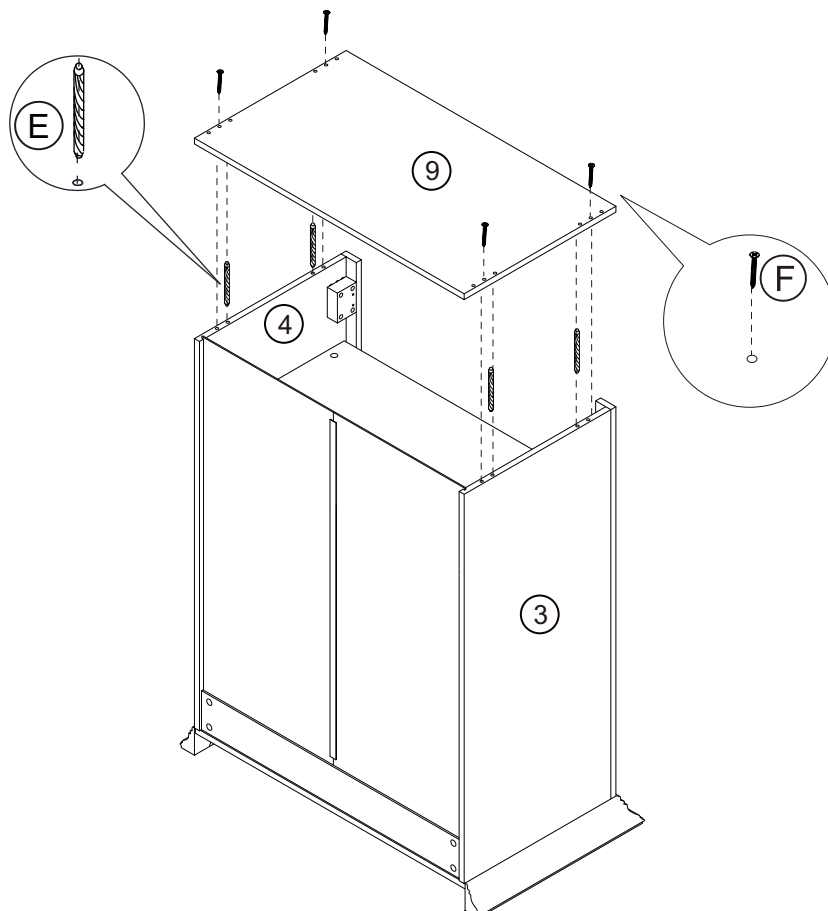
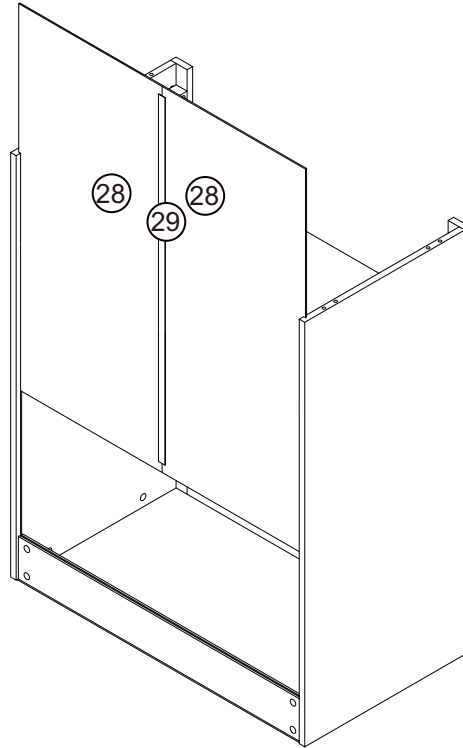

Assembly Instructions

Step 7

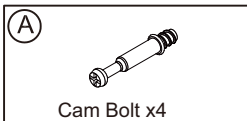
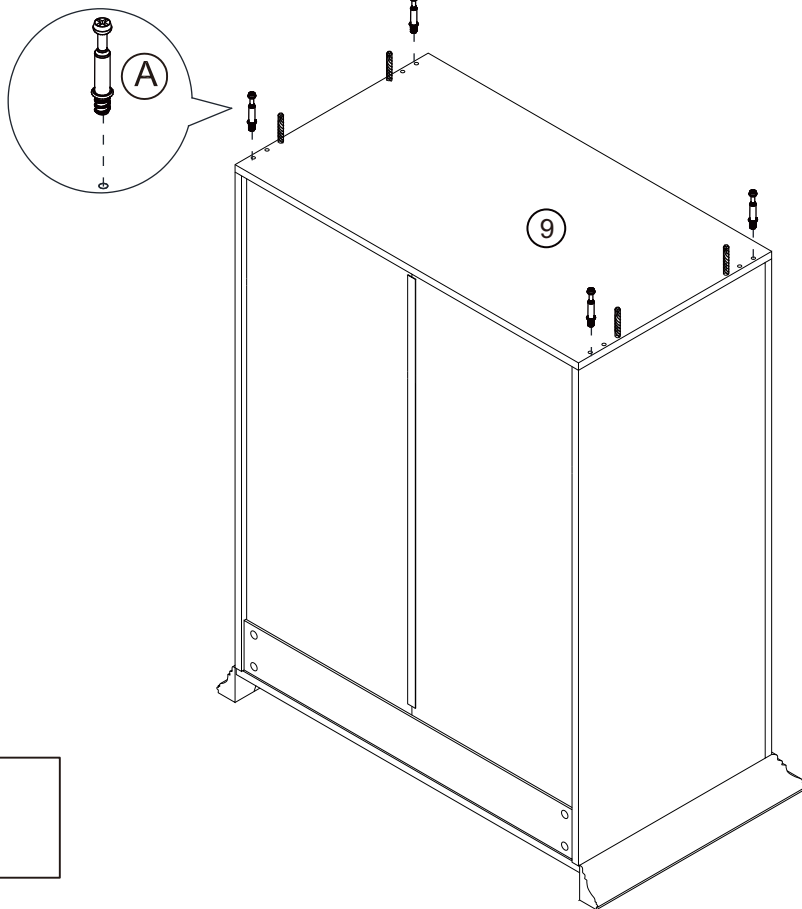



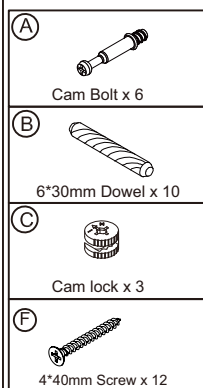
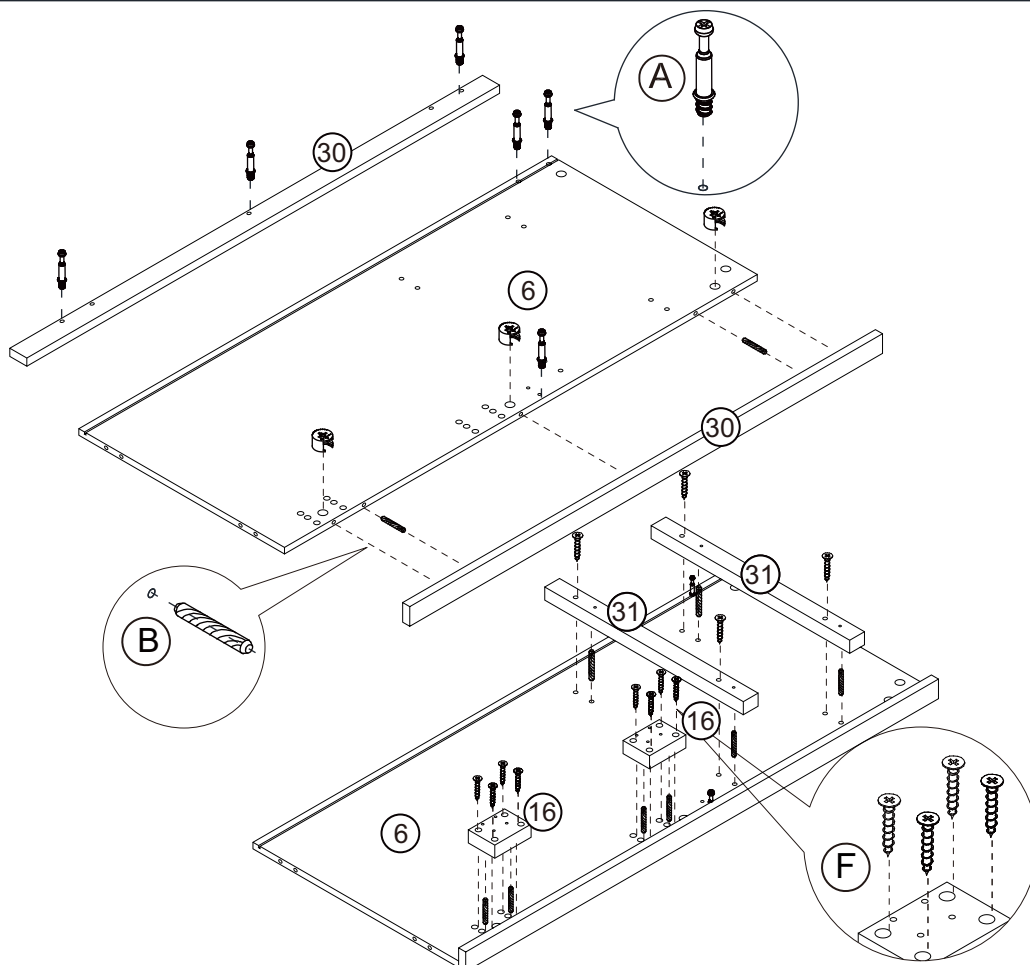

Step 8

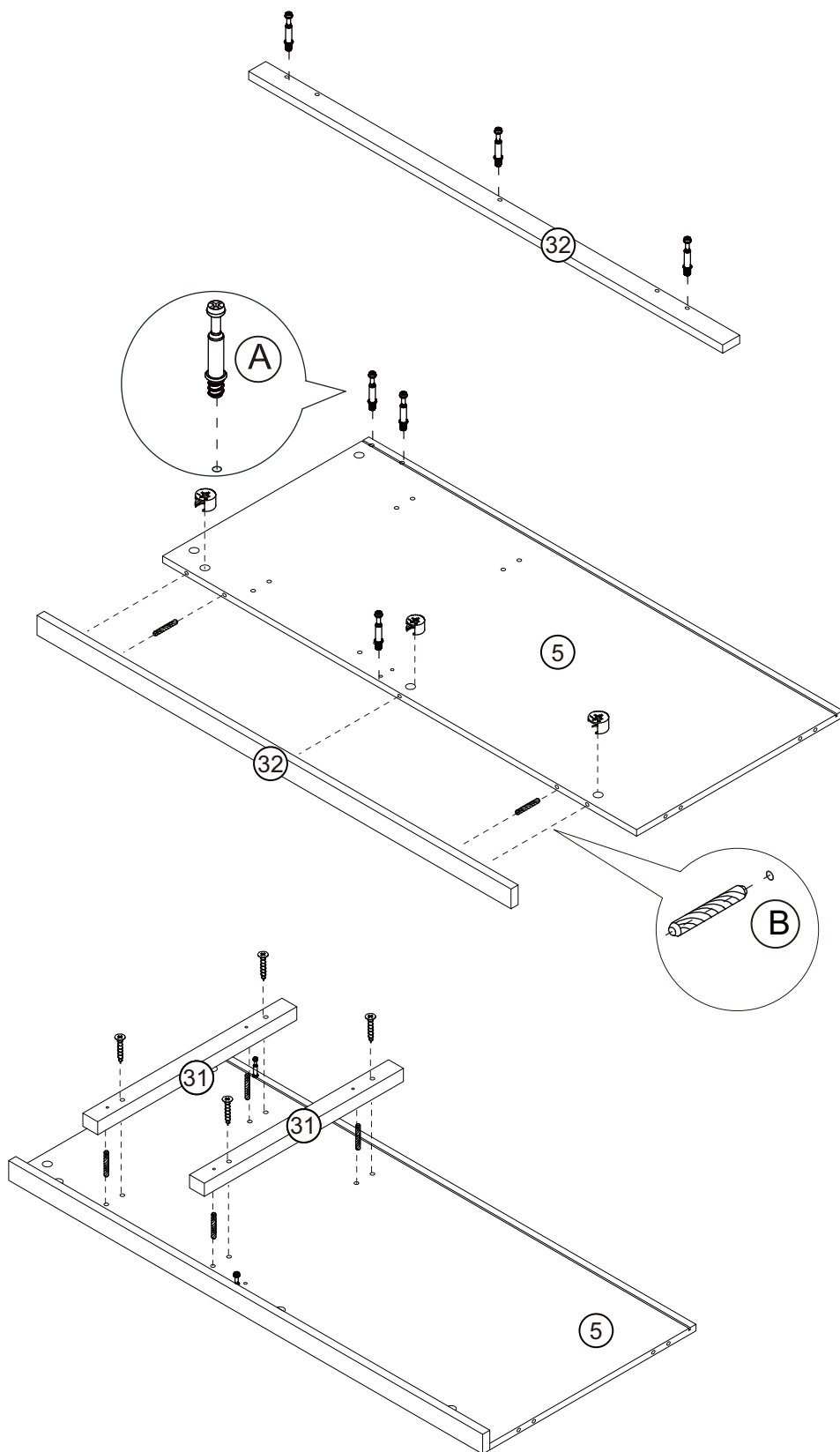

Assembly Instructions

Step 9



(A)	
(B)	
(C)	
(F)	

Assembly Instructions

Step 10

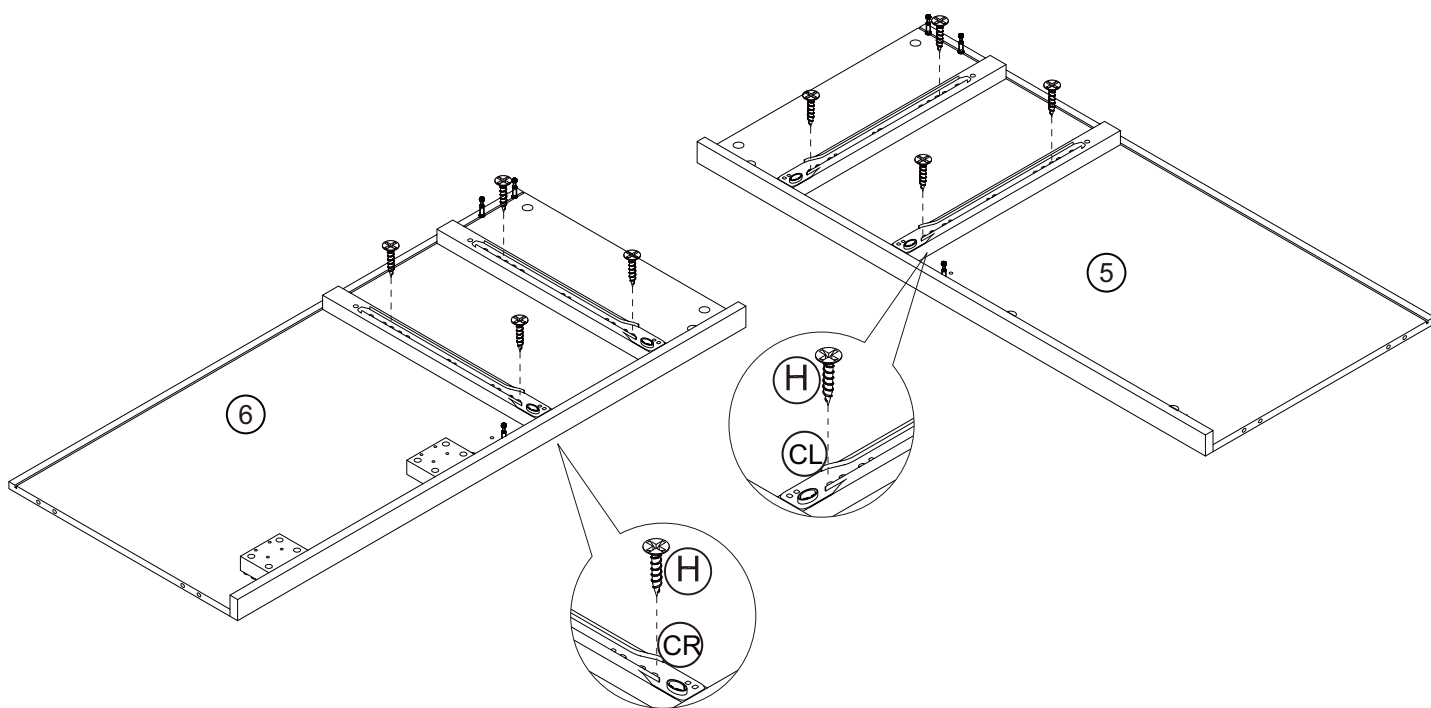
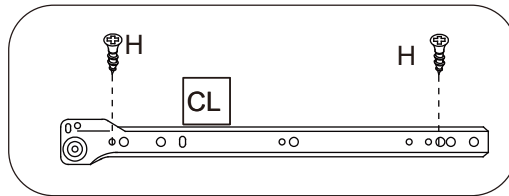
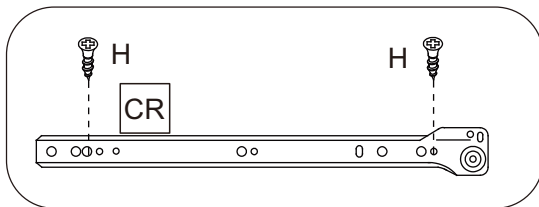

- | | |
|------|------------------|
| (H) | |
| | 3*12mm Screw x 8 |
| (CR) | |
| | 300mm runner x 2 |
| (CR) | |
| | 300mm runner x 2 |
| (B) | |
| | 6*30mm Dowel x 1 |
| (C) | |
| | Cam lock x 3 |

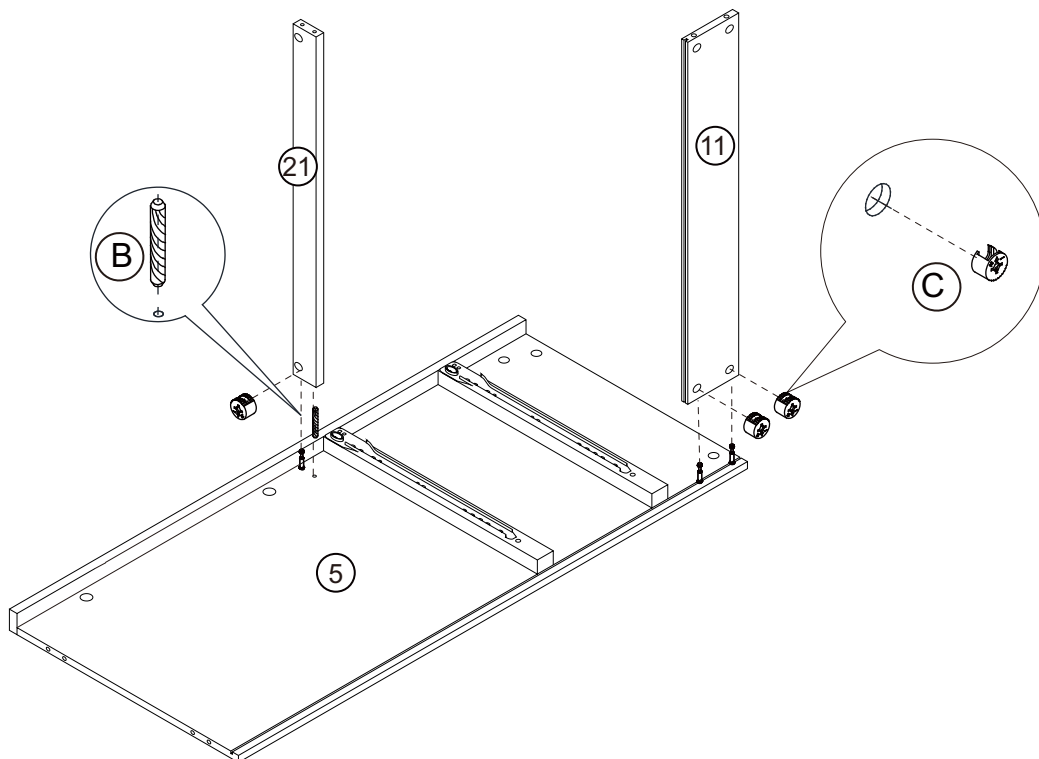

Assembly Instructions

Step 11

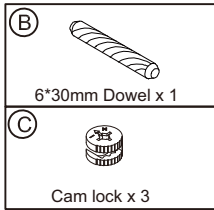
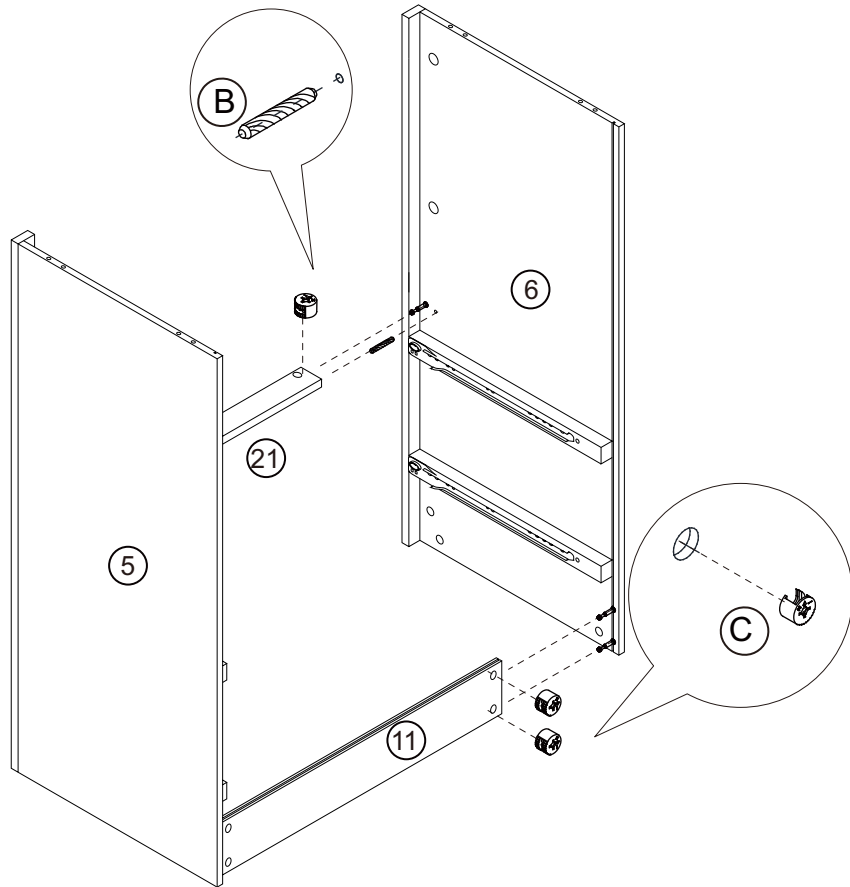

Step 12

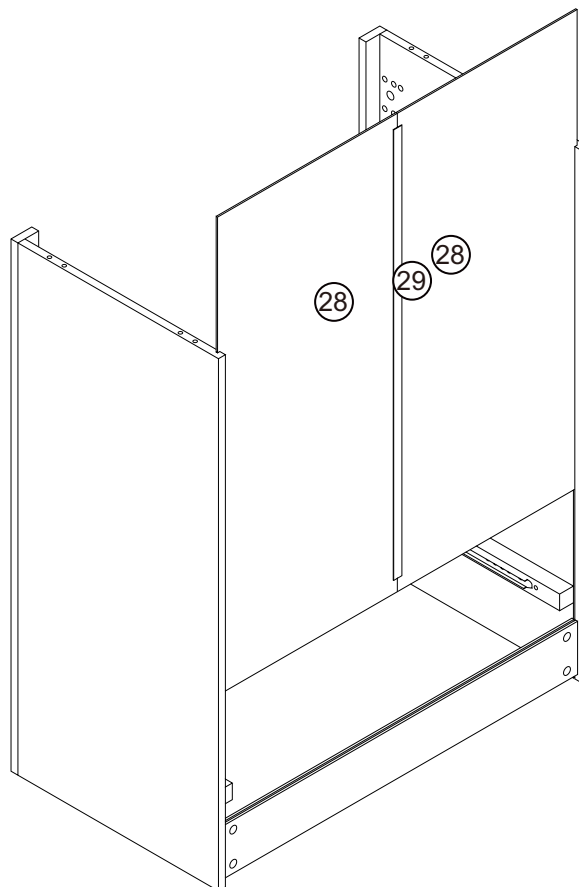

Assembly Instructions

Step 13

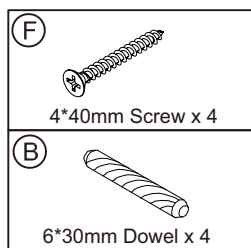
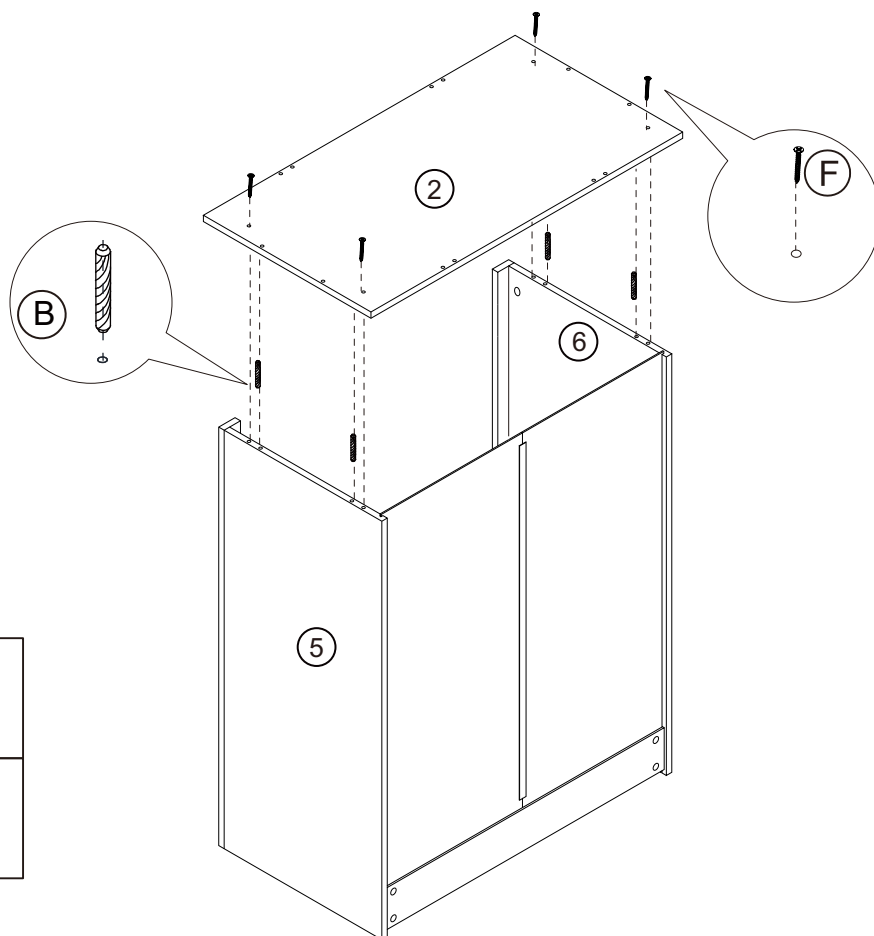

Step 14

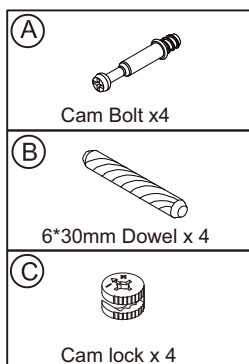
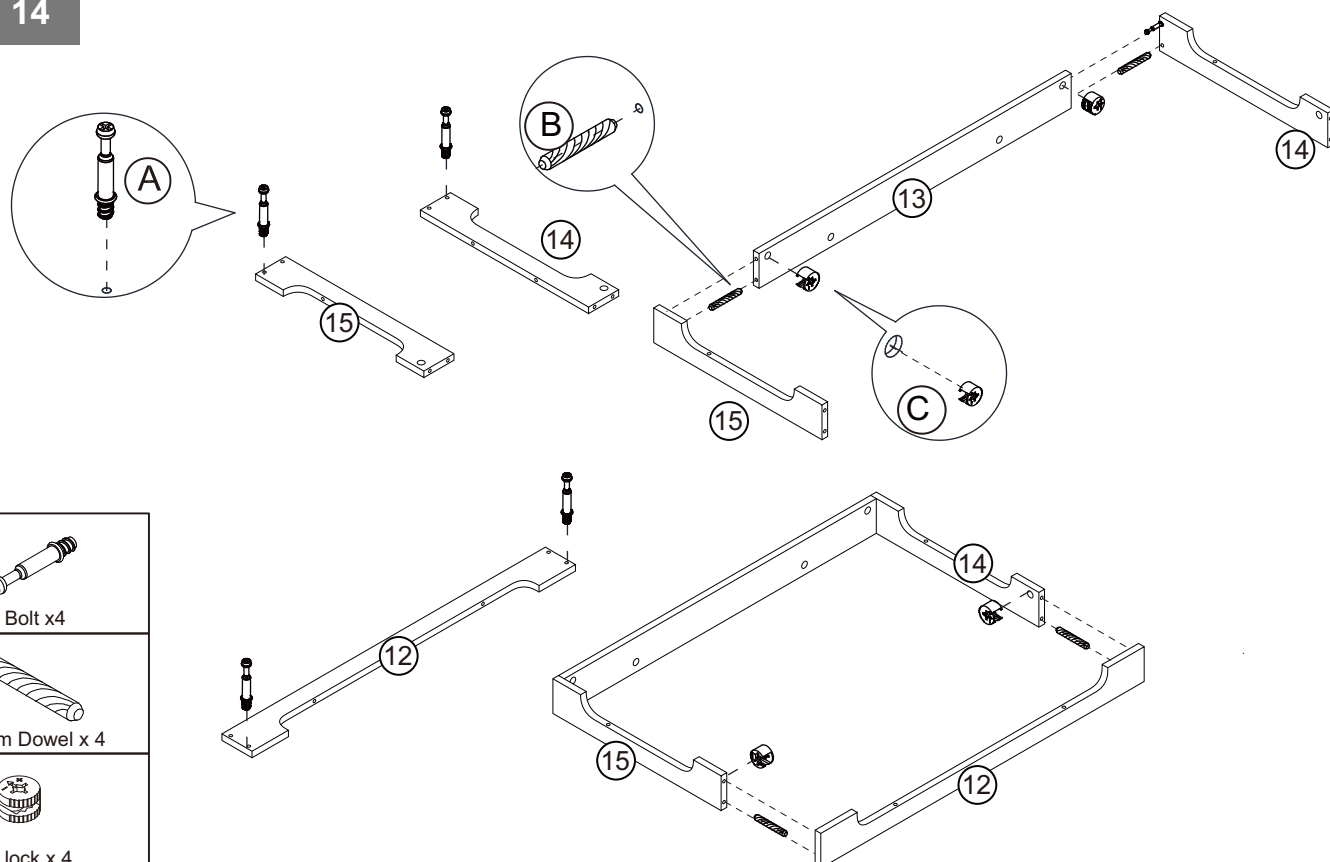

Assembly Instructions

Step 15

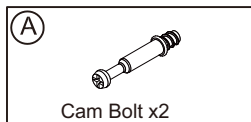
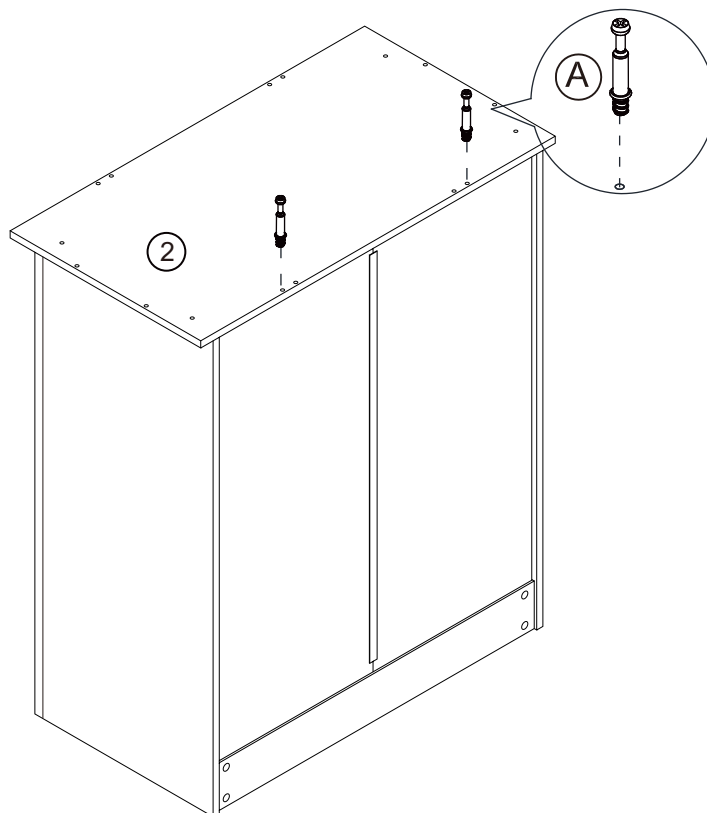

Step 16

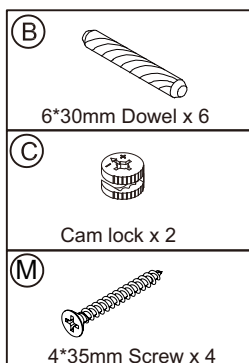
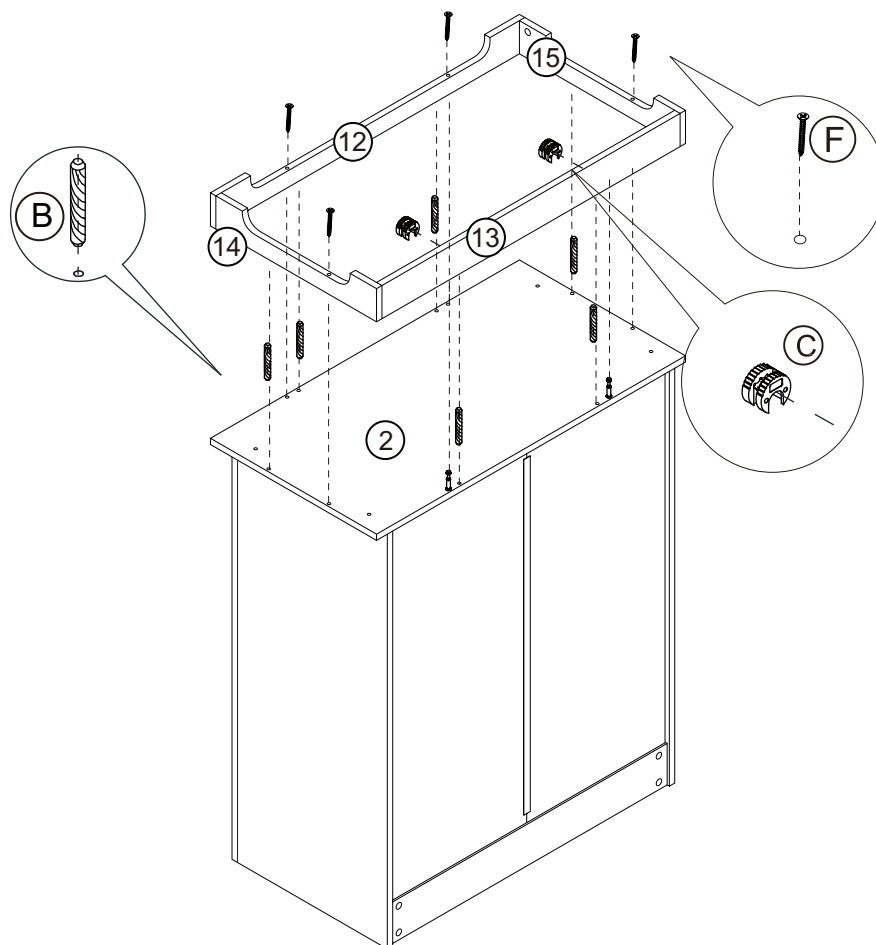

Assembly Instructions

Step 17

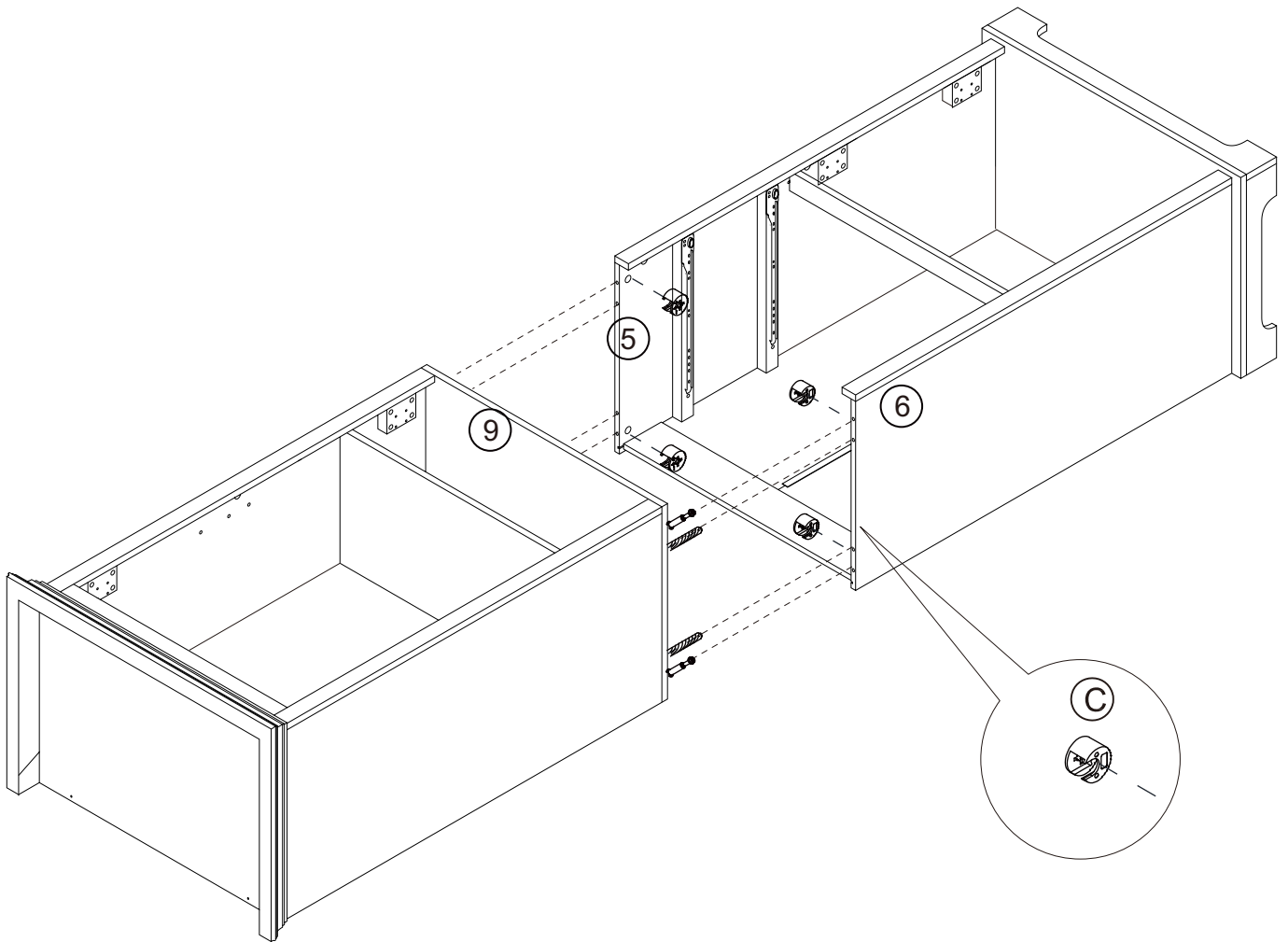

Assembly Instructions

Step 17

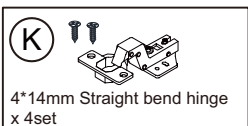
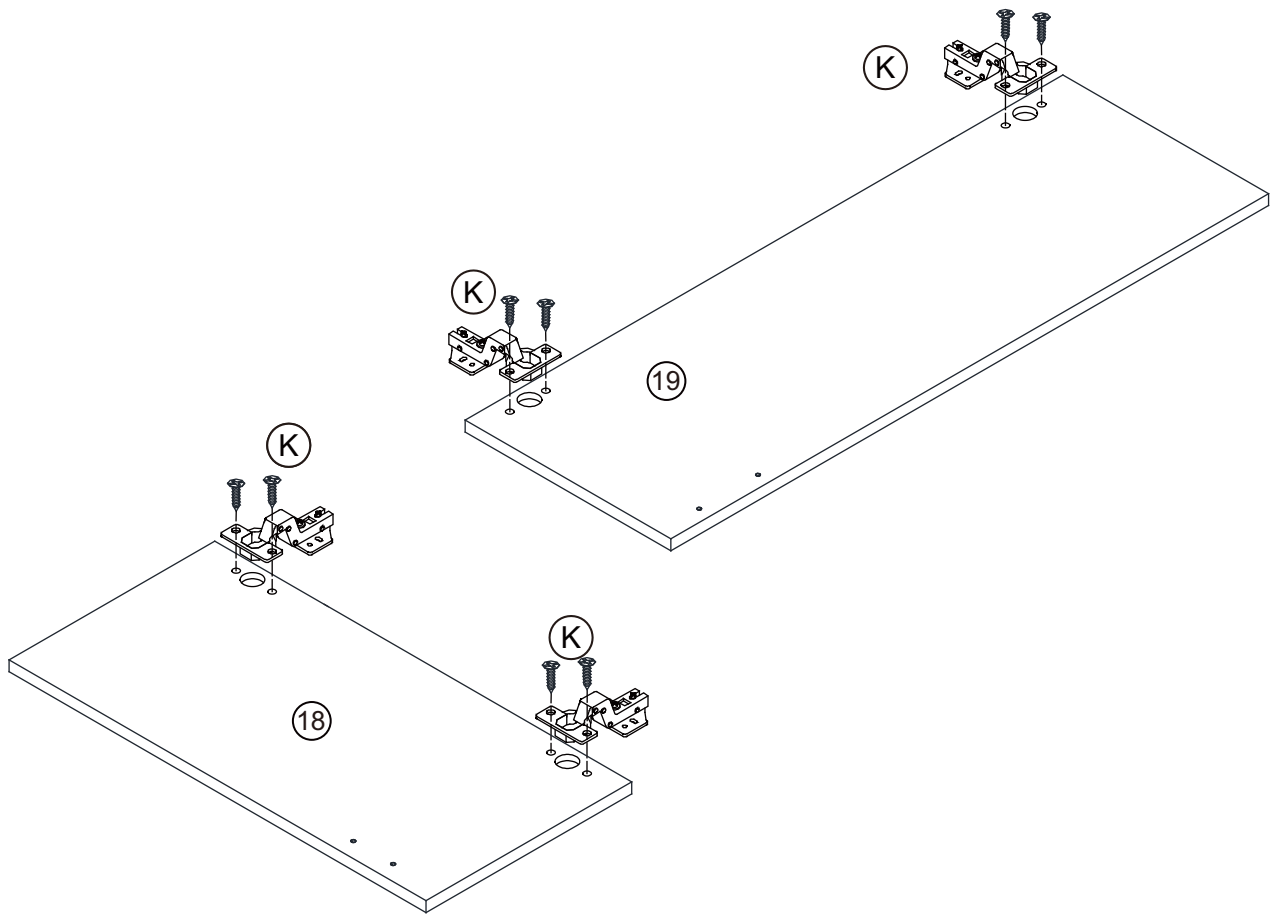

Assembly Instructions

Step 19

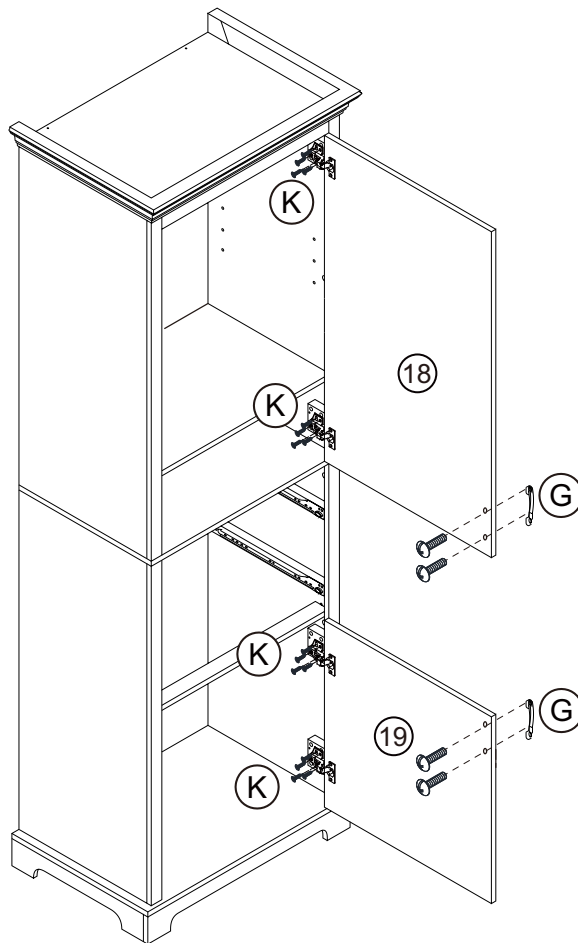

Step 20

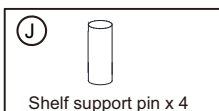
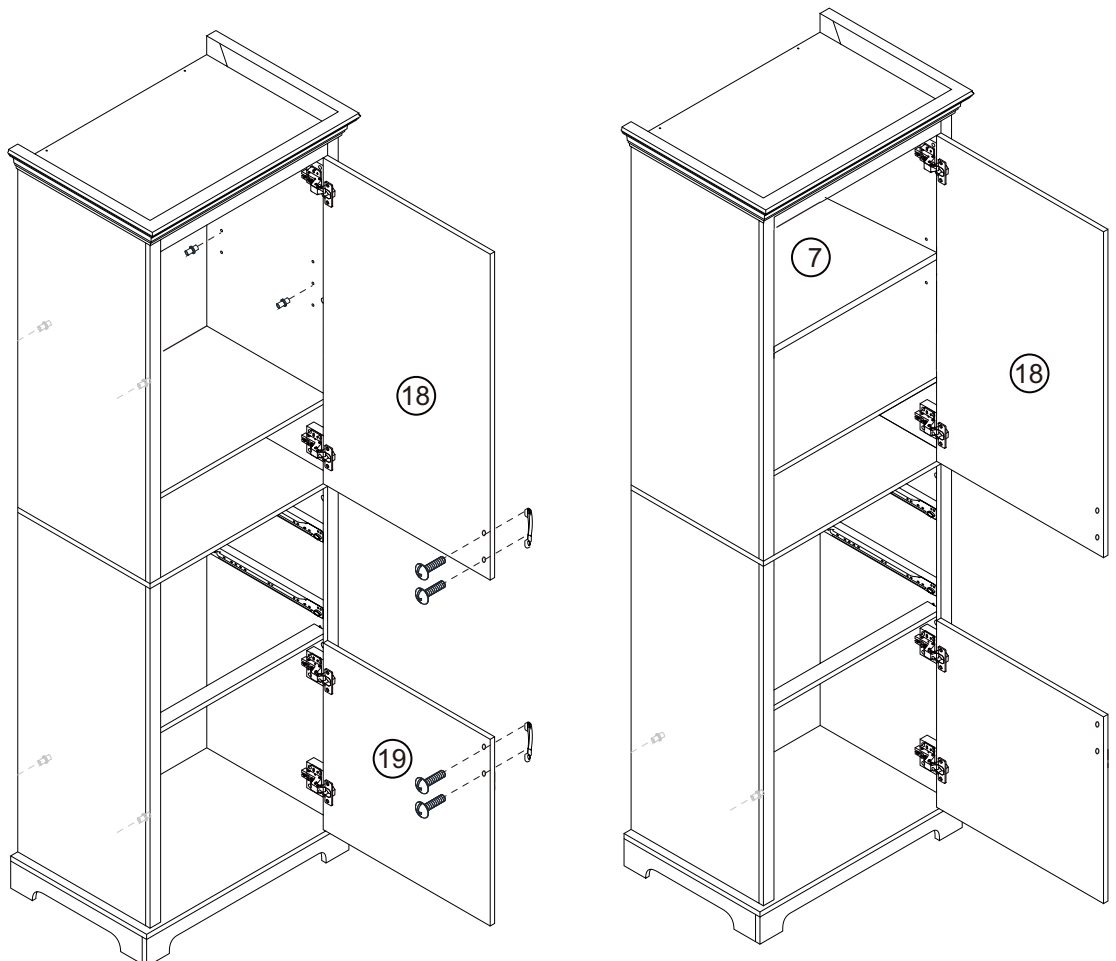

Assembly Instructions

Step 21

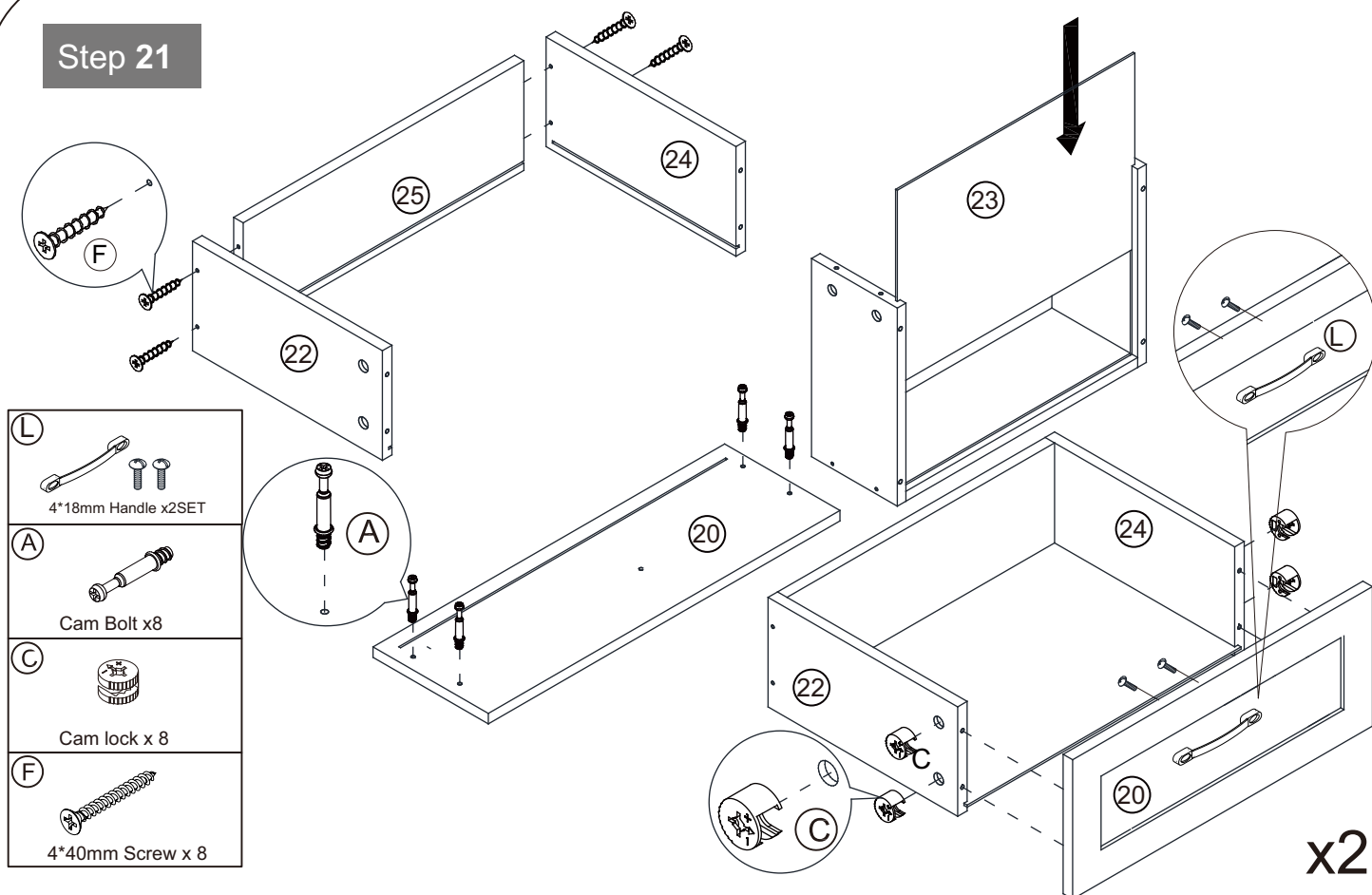

Step 22

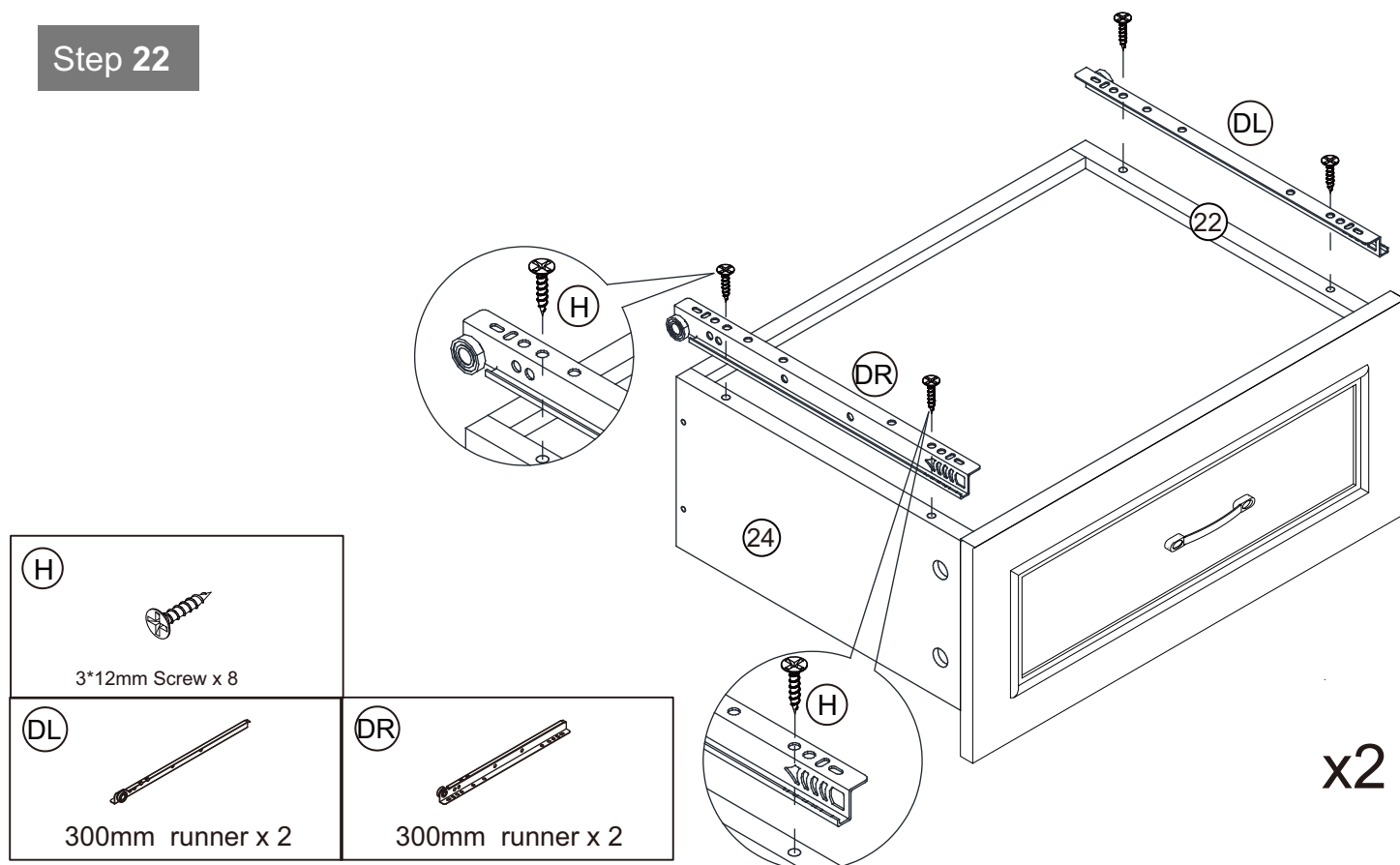

Assembly Instructions

Step 23

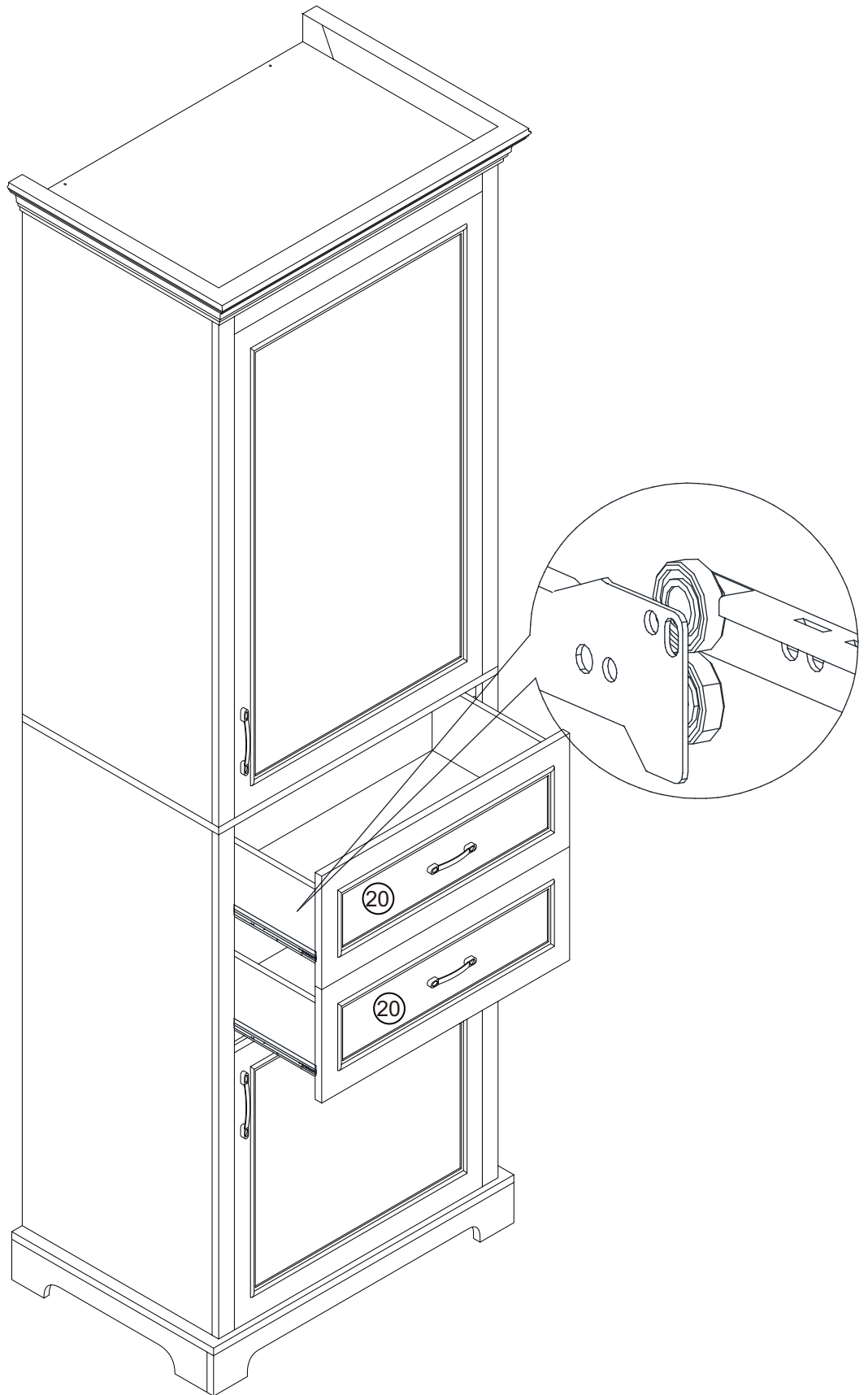

Assembly Instructions

Step 24

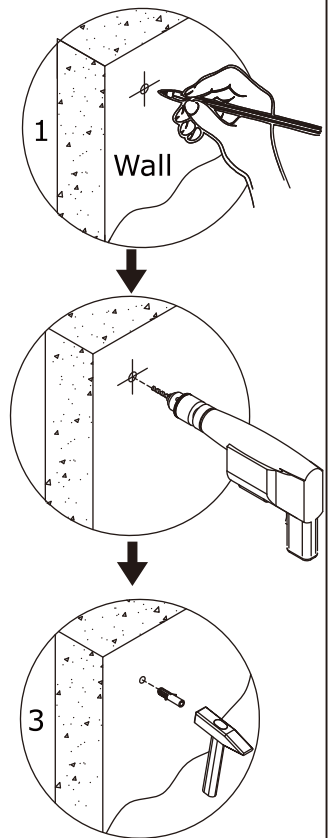
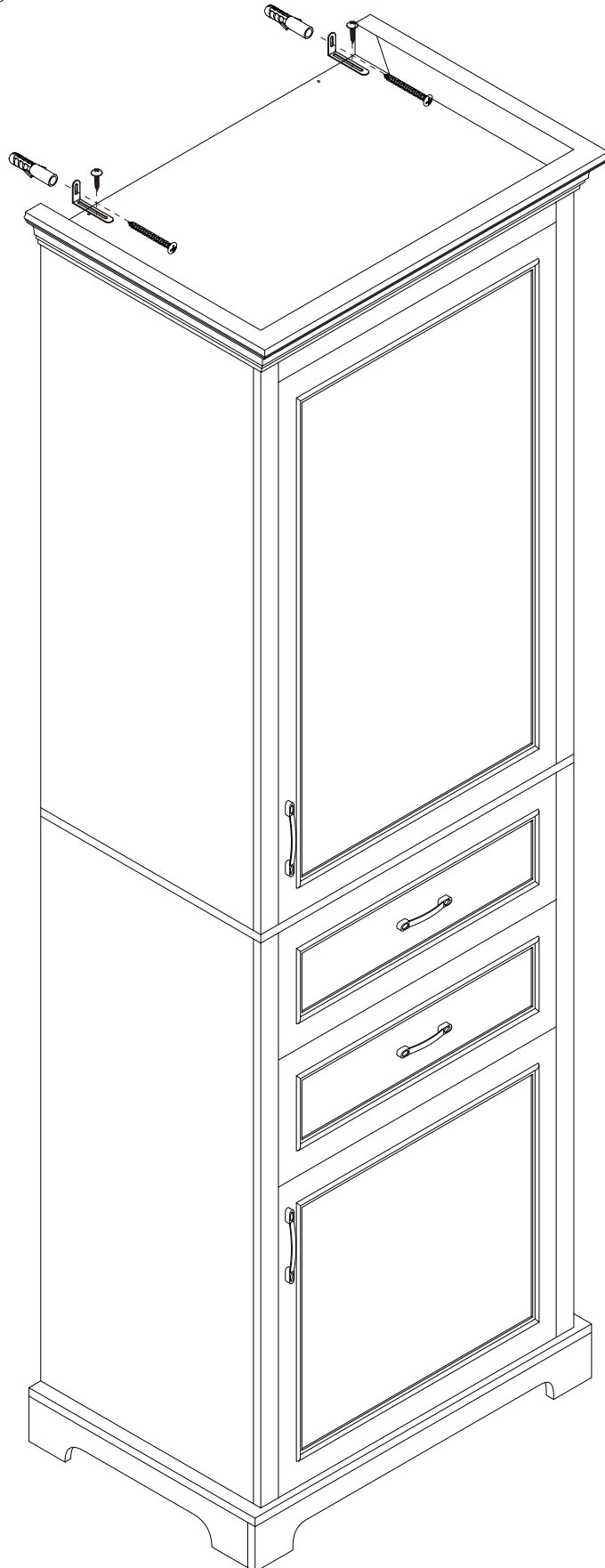

Anti-fall accessories x2