

# Aluminum Cantilever Umbrella

*Assembly and Operation Guide*

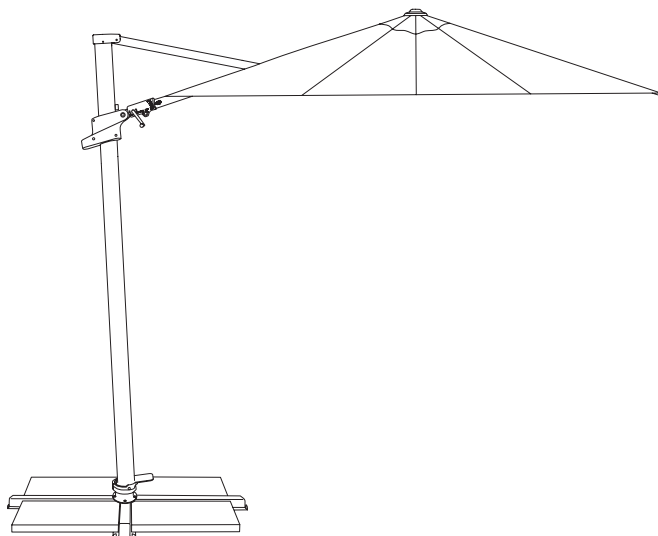

**11' Octagon**

Please remove all contents from the package, inspect and review checklist.

*Some parts may be included in the styrofoam packaging.  
Do not discard any packaging or box until assembly is complete.*

## CHECKLIST

- |                         |   |
|-------------------------|---|
| A - (2) Cross Bars      | F - (1) Crank Handle                          |
| B - (1) Rotation Hub    | G - (1) Canopy                                |
| C - (1) Main Frame      | H - (1) Light Adapter (light sold separately) |
| D - (1) Grip Handle     | I - (1) Hardware Assembly                     |
| E - (1) Crank Mechanism | J - (1) Protective Cover                      |

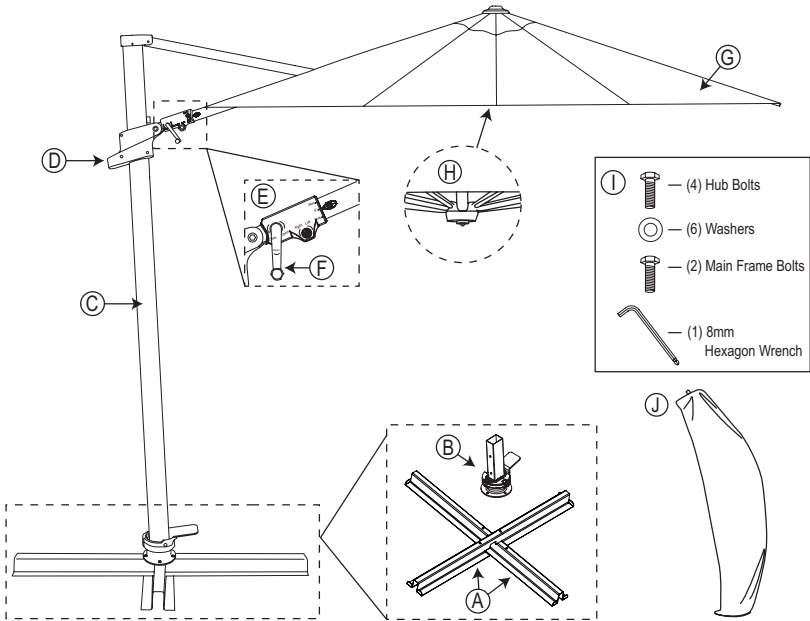

### REQUIRED FOR ASSEMBLY:

- Four (4) 50 lb. weights - square stones or concrete weights. (200 lb. total weight needed for support - **weights not included**) Stones & weights, standard sizes can be used up to 18" L x 18" W x 1.5" H.

**NOTE:** Using the cross bar stand without weights will damage your umbrella and may cause injury.

## STEP 1 Assemble Cross Bar Stand

---

### IMPORTANT:

Prior to assembly it is important to decide on the location of the umbrella.

- Allow ample height to avoid damage to your umbrella during assembly and usage.
- Choose a location that is level and sturdy.
- Avoid any sloping or soft ground.
- Consider a location that will maximize the umbrella's 360° rotating function. Placing the umbrella between two entertaining areas is idea.

- 
- Remove rotation hub from the main frame (Fig. 1).
  - Set cross bars in a cross position (Fig. 2).
  - Place rotation hub on cross bar stand and attach (4) supplied hub bolts and (4) washers with 8mm hexagon wrench (Fig. 3 and Fig. 4).
  - Secure cross bar stand with (4) 50 lbs. square stones or concrete weights (not included) (Fig. 5).

### IMPORTANT:

- Cross bar stand will not support umbrella without proper weights. Using the stand without weights will damage your umbrella.

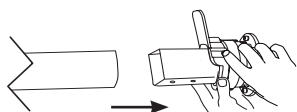

(Fig. 1)

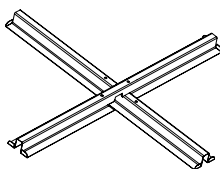

(Fig. 2)

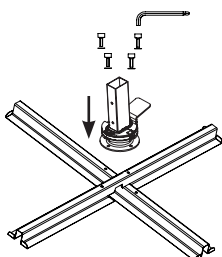

(Fig. 3)

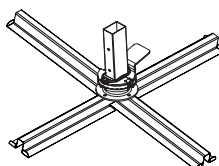

(Fig. 4)

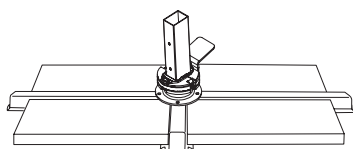

(Fig. 5)

Stone / Pavers  
(not included)

## STEP 2 Assemble Frame

---

- Using a two person team, lift umbrella and slide umbrella over rotation hub (Fig. 6).
- Secure umbrella to rotation hub with (2) main frame bolts and (2) washers using 8mm hexagon wrench (Fig. 7).
- Insert crank handle fully into “open/close” socket (Fig. 8). Crank handle will snap into place.

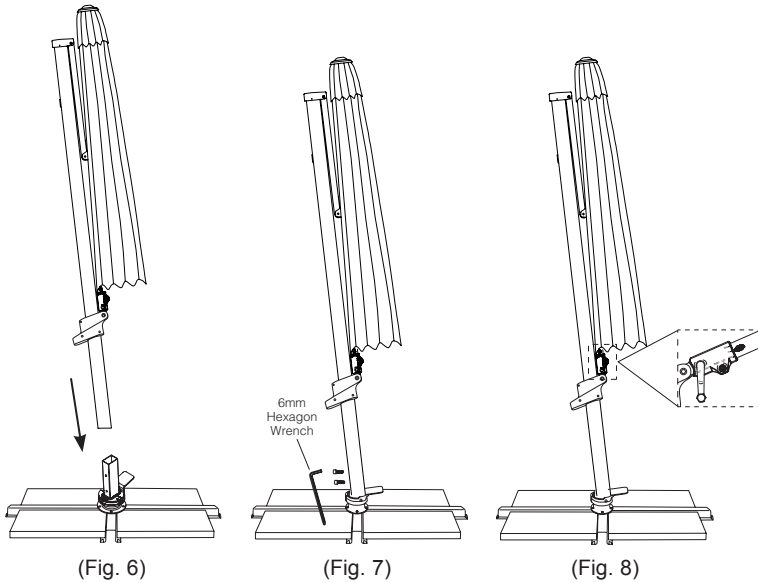

### STEP 3 Opening Umbrella

---

- Position yourself behind umbrella.
- Squeeze the grip handle and slide handle midway up main frame. Release grip handle to lock into place.
- Slowly turn the crank handle clockwise to open umbrella (Fig. 9).
- Once fully opened, squeeze the grip handle to release lock and continue to slide handle upward until desired height is reached (Fig. 10).

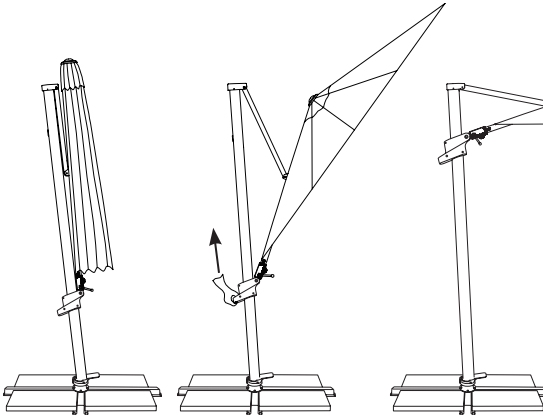

(Fig. 9)

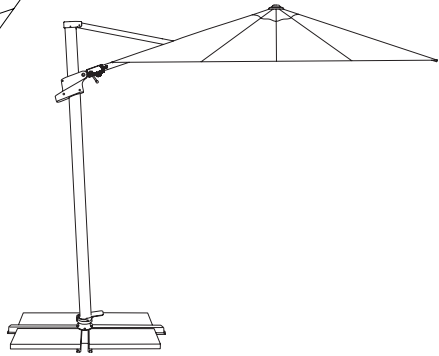

(Fig. 10)

## STEP 4 Tilting Umbrella

---

### **IMPORTANT: PRIOR TO USING TILT FEATURE.**

To avoid personal injury or damage to the umbrella, make sure the area behind you is clear and free from any furniture or structure.

### **To Tilt Canopy Vertically:**

- Position yourself behind umbrella. Make sure canopy is in open position.
- Squeeze grip handle to disengage from track and guide grip down main frame until desired degree of vertical shade is reached (Fig. 11).
- Release grip handle to lock into place.

### **WARNING:**

- Make sure tilt is secure in track. Do not tilt umbrella past the track.
- Keep hands free of main frame while moving grip handle up and down.
- Do not use tilt functions during winds.

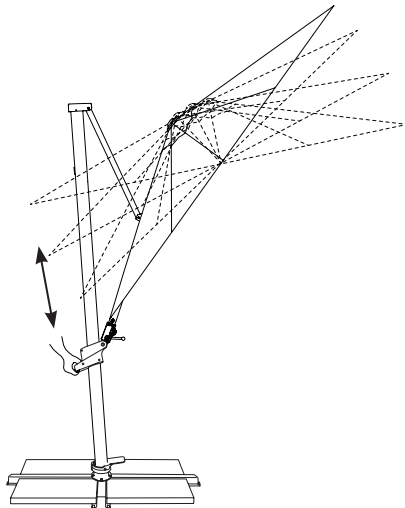

(Fig. 11)

**To Tilt Canopy Horizontally:**

- Position yourself behind umbrella. Make sure canopy is in open position.
- Insert crank handle into “Right/Left” socket in crank mechanism (Fig 12).
- To tilt canopy right, turn crank handle counter clockwise.
- To tilt canopy left, turn crank handle clockwise.

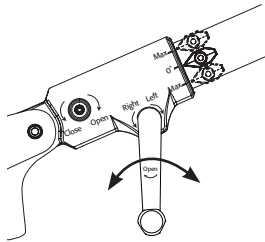

(Fig. 12)

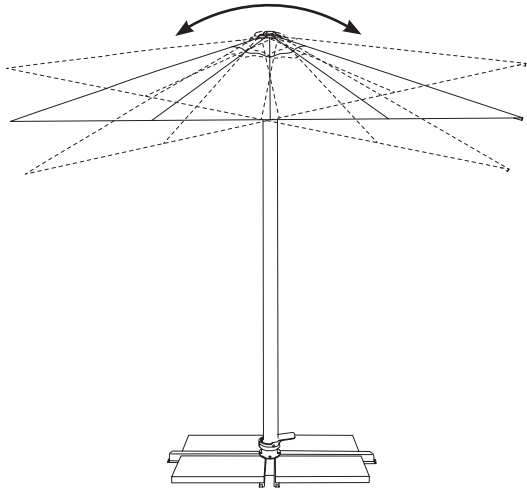

## STEP 5 Rotating Umbrella

---

- Place your foot on the foot pedal of the rotation hub and step-on the foot pedal to release rotating lock (Fig. 13).
- Place hands on the main frame and rotate the umbrella frame in either direction until desired position is reached.
- Step off the foot pedal to engage rotating lock and lock position (you will hear the pedal click, as it reaches the next available lock position).

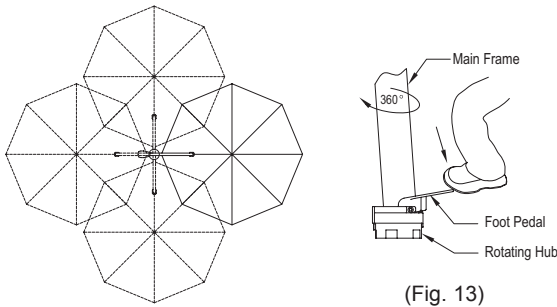

## STEP 6 Light Adapter Feature

---

### To Attach Umbrella Light: *(light sold separately)*

- Loosen the light adapter built into the umbrella runner by turning counter-clockwise (Fig. 14).
- Pull down light adapter post to attach the umbrella light (sold separately) (Fig. 15).

### To Remove Umbrella Light and Close Light Adapter:

- Remove umbrella light from light adapter post.
- Gently push up the light adapter post back into umbrella runner and tighten turning clockwise (Fig. 14).

### Note:

- It may be necessary to lower umbrella to a reachable height to pull light adapter down and attach umbrella light.

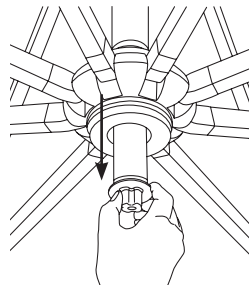
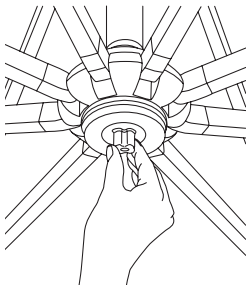

## STEP 7 Closing Umbrella

---

**IMPORTANT:** When closing the umbrella, the canopy must be in a horizontal position, or damage to umbrella may occur.

- Insert crank handle into “Close/Open” socket in crank mechanism.
- Turn crank handle counter clockwise until the canopy is closed (Fig. 16).
- Squeeze grip handle and slide handle down until umbrella has fully closed (Fig. 17).
- Tie string around canopy to secure canopy.
- Cover umbrella with provided protective cover when not in use (Fig. 18).

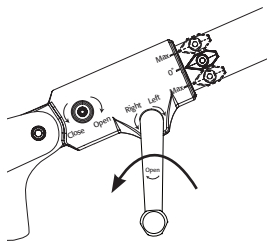

(Fig. 16)

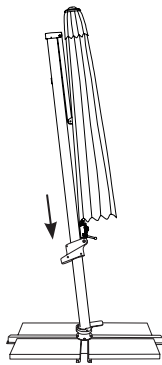

(Fig. 17)

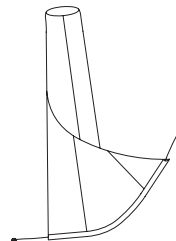

(Fig. 18)

## CARE AND MAINTENANCE

- When not in use, close and cover umbrella with provided protective cover.
- Allow a wet canopy to dry while in open position, but do not leave unattended.
- If necessary, clean the fabric with lukewarm water, mild detergent, and a sponge.
- Wipe sliding marks on the aluminum poles with a damp cloth.

### Winter Storage:

- Store in a dry place.

### After the Winter:

- Check the condition and function of the umbrella. Any defects must be repaired by a professional.

### TO PROPERLY FOLD CANOPY:

The canopy will last longer if you fold it as it was packed and shipped. This technique is similar to the way a parachute is folded and is especially important when folding the canopy for seasonal storage or when left in the closed position for an extended period of time.

Using this technique at all times will significantly extend the life of the canopy.

- When the umbrella has been fully closed, stand in front of the canopy structure and begin the folding process by pulling out two panels opposite the cantilever pole. Pull the two panels together and roll tight into the canopy.
- Once rolled tight, pull adjacent panels out one at a time and fold to the center, alternating sides until all the panels have been pulled out from the arms and folded into the center.
- Tie string around canopy and cover umbrella with protective cover.

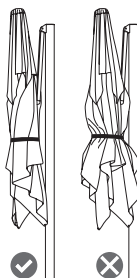

## SAFETY PRECAUTIONS

- To reduce risk of personal injury in which a person is injured or harmed, and/or damage to personal property, read and follow the Assembly Guide prior to assembling and operating umbrella and base.
- Close and store the umbrella in windy conditions or when a storm approaches. Never allow the umbrella to flap in the wind; this could cause personal injury, damage to personal property, damage to umbrella and/or umbrella canopy. Do not use tilting function during windy conditions.
- Keep umbrella secured to umbrella base at all times.
- Do not leave open umbrella unattended. If damage occurs, this is not covered by the warranty.
- When adjusting the umbrella, make sure that no person(s), item(s) or personal property are close to the umbrella. This is important to prevent injury or material damage.
- Do not allow children to play on or with umbrella or umbrella base.
- When adjusting or assembling the umbrella or umbrella base, make sure fingers, toes or any other parts of the body are clear from moving parts. Failing to do so may result in serious injury.

