

As this item contains many parts, please read the installation instruction carefully before installation . Please use tools properly and carefully. If you have any questions about the product and installation, please contact us.

Our professional after-sales team will serve you online all day.

Before You Start

- ✓ Read through each step carefully and follow the proper order
- ✓ Separate and count all your parts and hardware
- ✓ Give yourself enough room for the assembly process

Helpful Hints

PEOPLE NEEDED FOR ASSEMBLY: 1-2

- Open your item in the area you plan to keep it to avoid excessive heavy lifting.
- Identify, sort and count the parts before attempting assembly.
- Do NOT use harsh chemicals or abrasive cleaners on this item.
- Never push, pull, or drag your furniture.



Part List

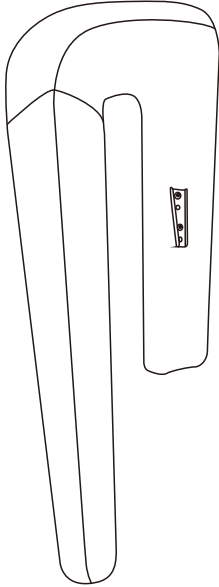

Ⓐ LEFT ARMREST
QTY:1

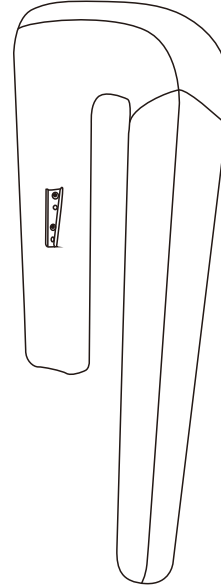

Ⓑ RIGHT ARMREST
QTY:1

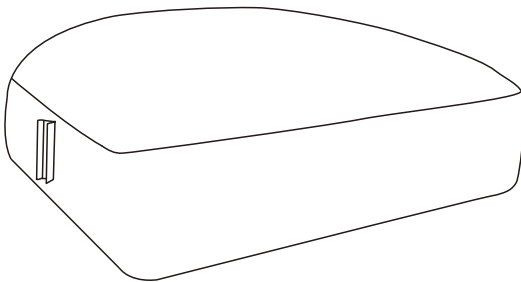

Ⓒ SEAT
QTY:1

STEP1

Place the seat(C) upside down on a clean bench.

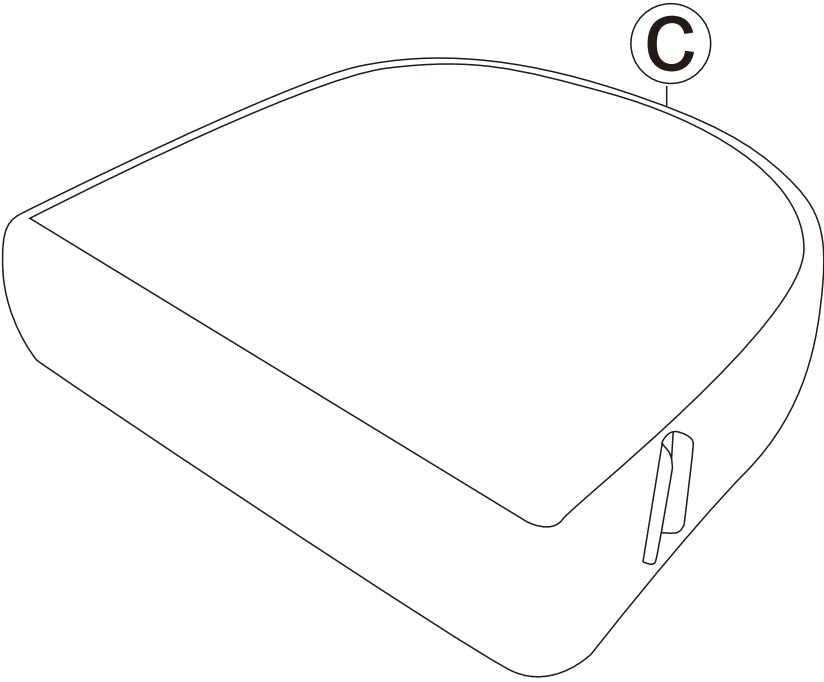

STEP2 Carefully align male and female metal brackets on both sides then push the left armrest(A) to seat (C) all the way down to secure.

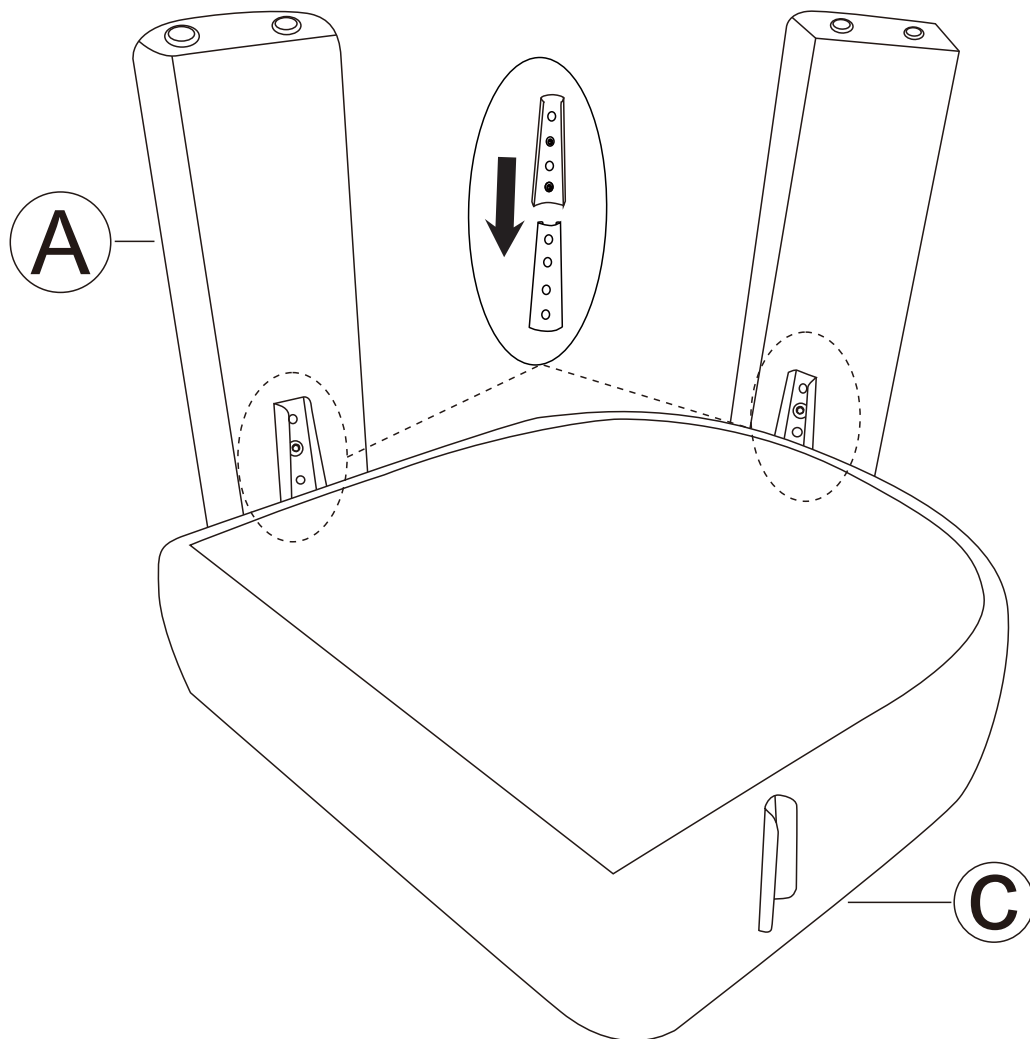

STEP 3 Carefully align male and female metal brackets on both sides then push the right armrest(B) to seat (C) all the way down to secure.

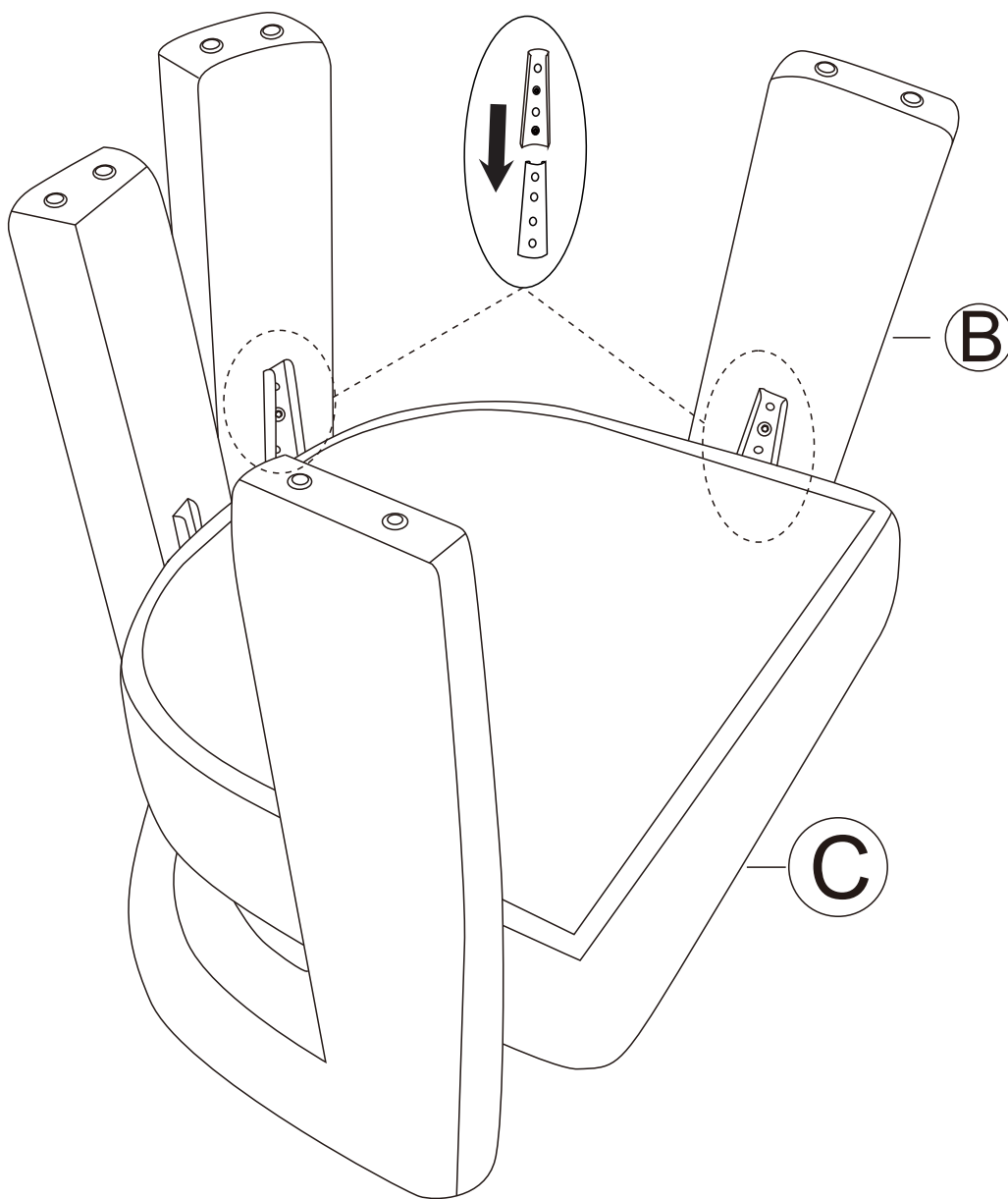

STEP 4 Turn the assembled seat upright.
If you find the chair not level, please adjust by rotating the feet pads on the legs.

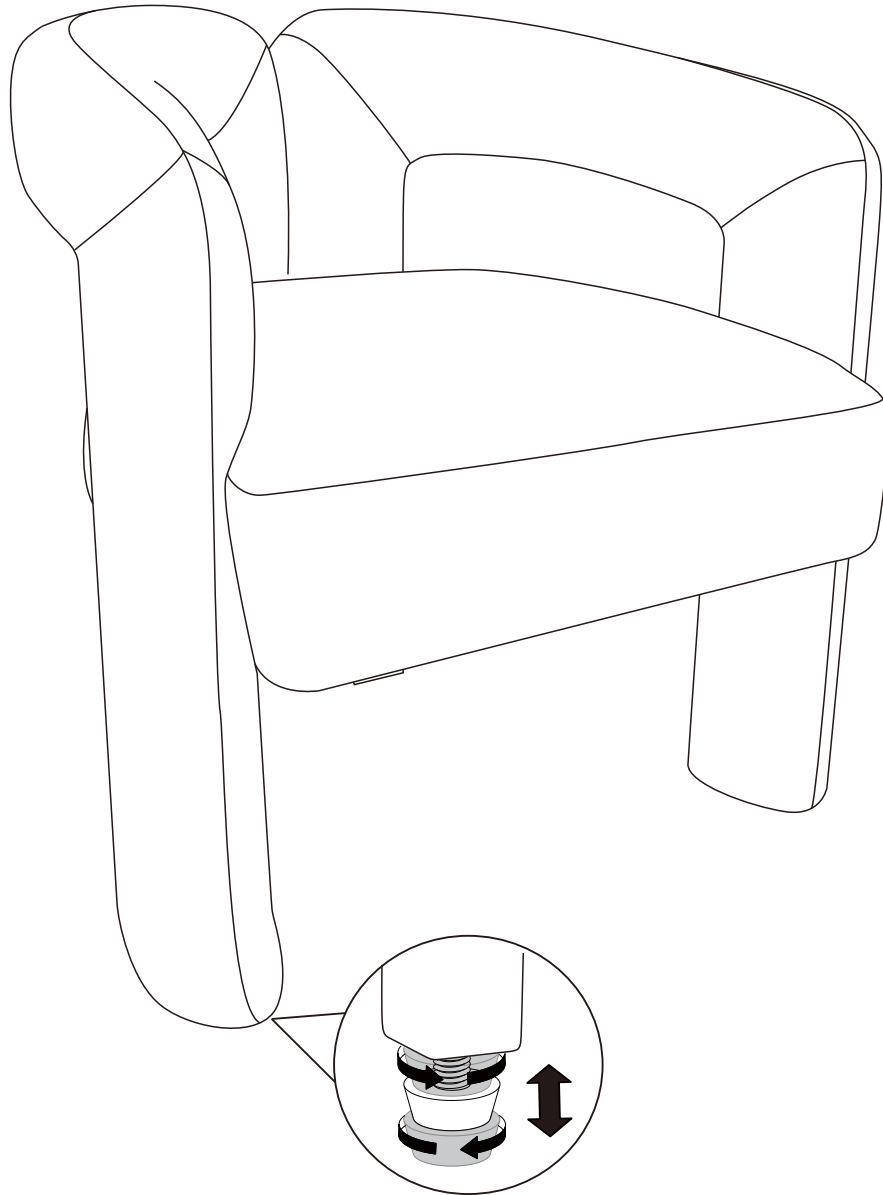

STEP5 Assembly completed.

