

F06L572&F06L573&F06L574
6-Piece Wicker Sectional Sofa Wedge Set

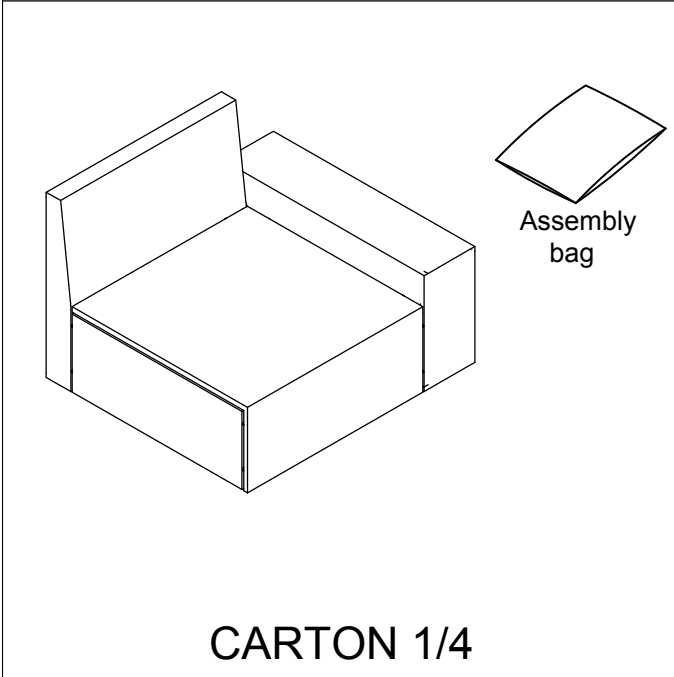

CARTON 1/4

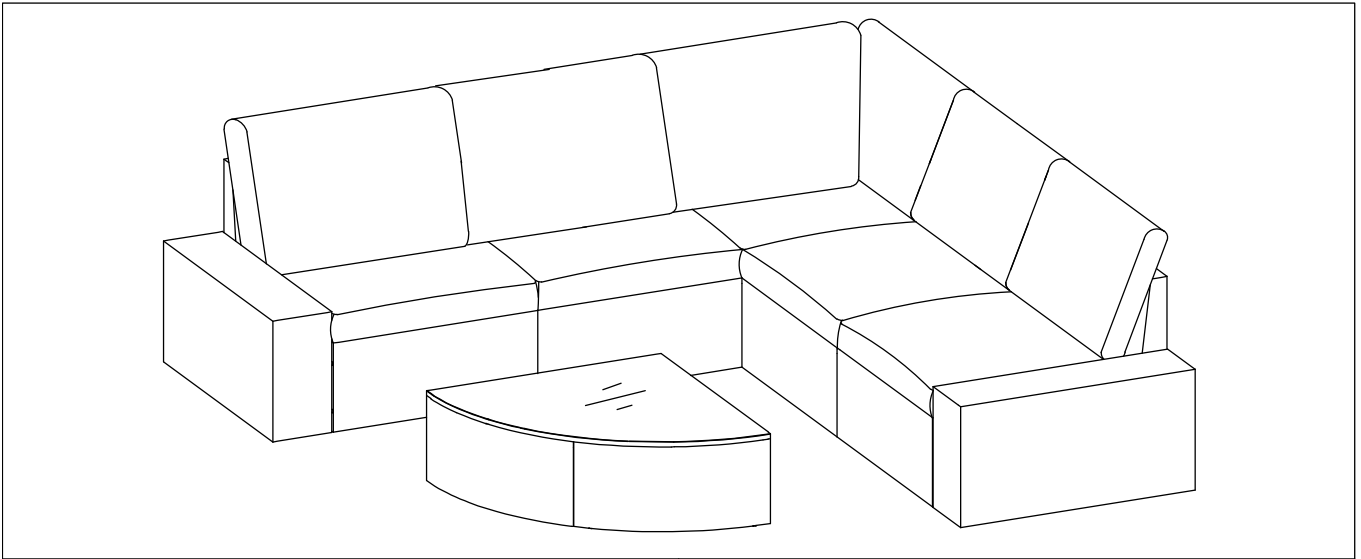
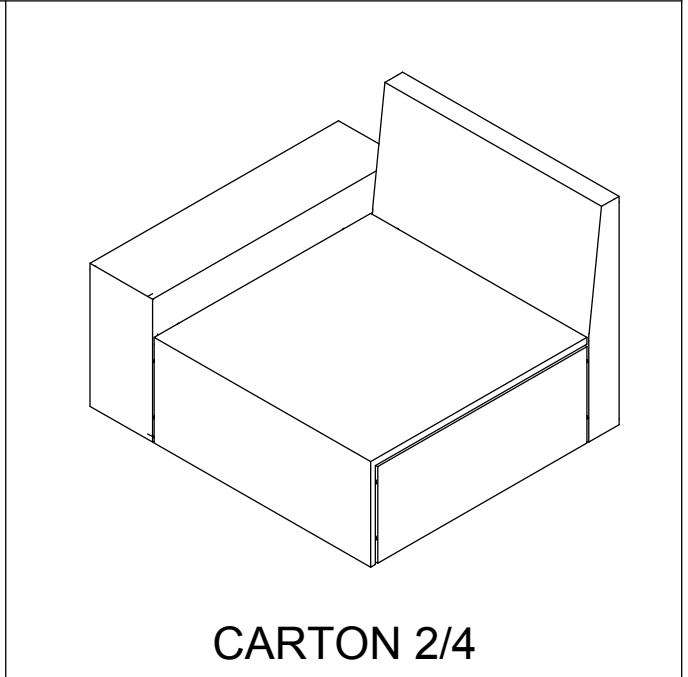

CARTON 2/4

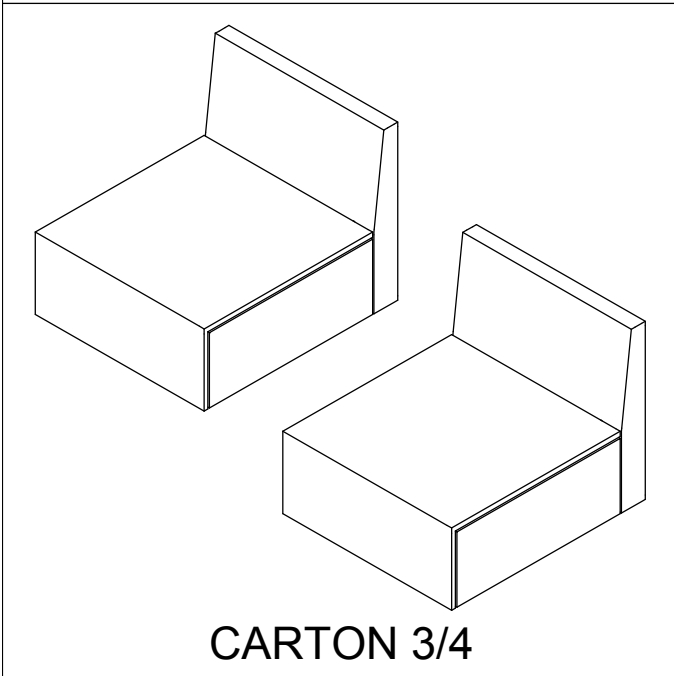



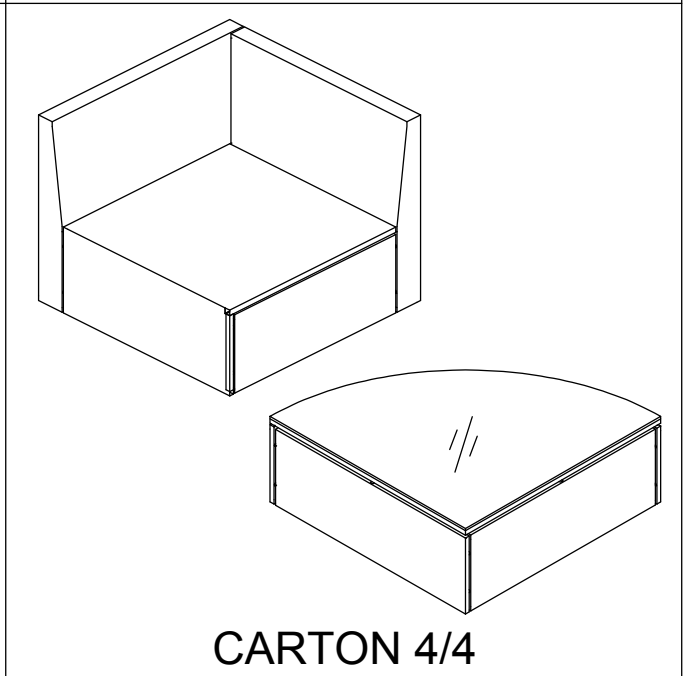

CARTON 3/4

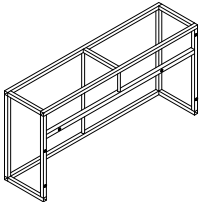
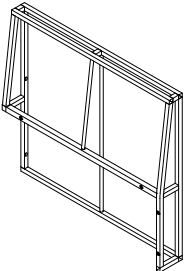
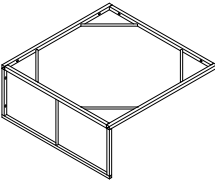
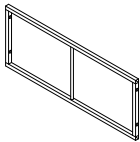

CARTON 4/4

F06L572&F06L573&F06L574

Right End Seat

Item no.	Reference Image	Description	Qty.
A		Right Arm Rest	1
B		Seat Back	1
C		Seat Base	1
D		Side Panel	1
K		M6 x 35 Socket Head Cap Screw	4
L		M6 x 30 Socket Head Cap Screw	7
G		Flat Washers	11
I		4-mm Allen Key	1

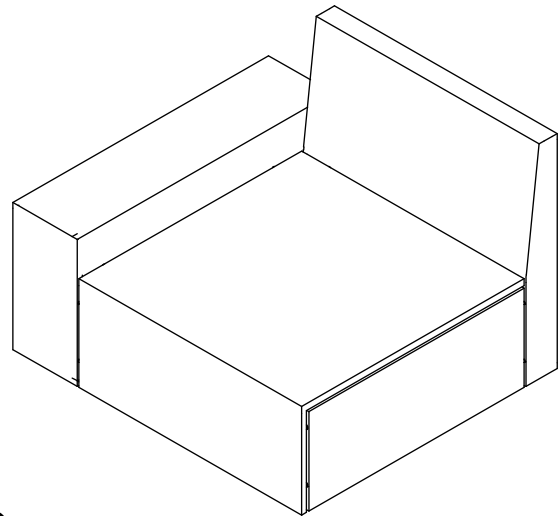

1

Attach the right arm rest (A) and the seat back (B) using a M6 x 30 socket head cap screw (L) with a flat washer (G). Do this in two places.

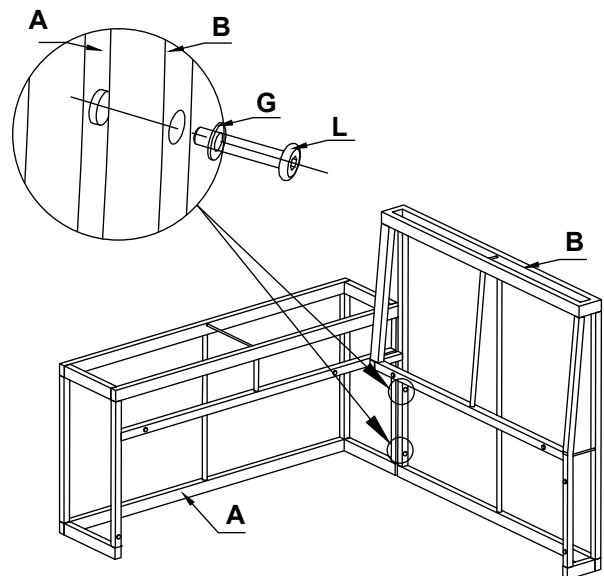

2

Flip the assembly upside down. Attach the seat base (C) to the assembly (A/B) using a M6 x 30 socket head cap screw (L) with a flat washer (G).

Secure the side and back holes with M6 x 35 socket head cap screws (K) with flat washers (G). Do this in four places.

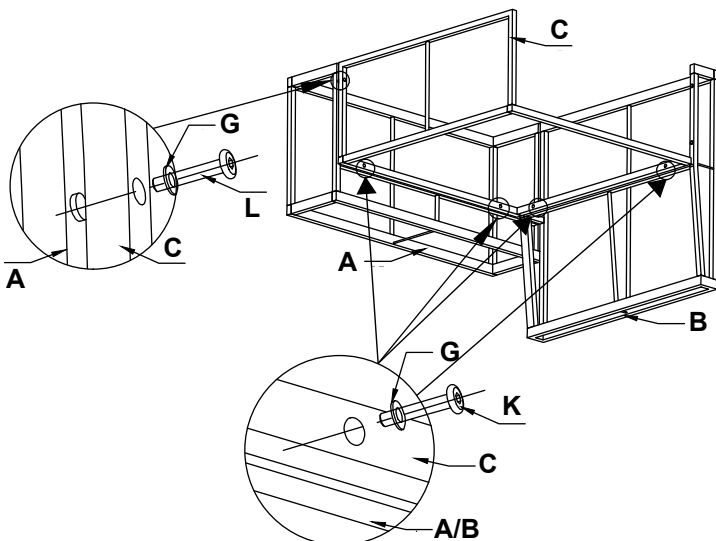

F06L572&F06L573&F06L574**Right End Seat****3**

With the assembly still flipped over, attach the side panel frame (D) using M6 x 30 socket head cap screws (L) with flat washers (G). Do this in four places.

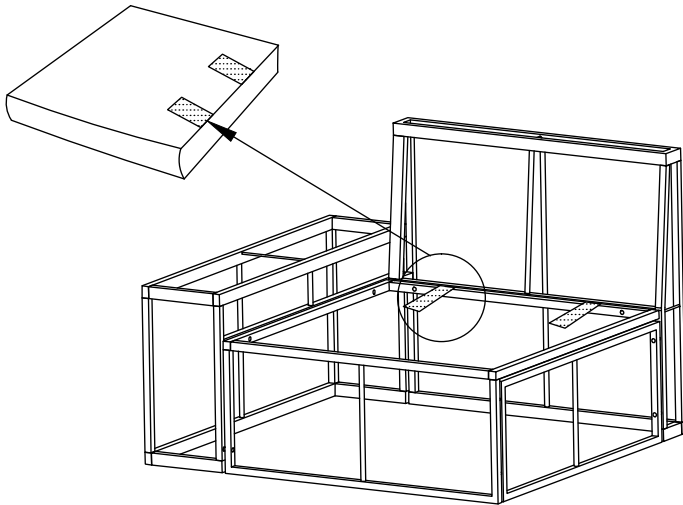
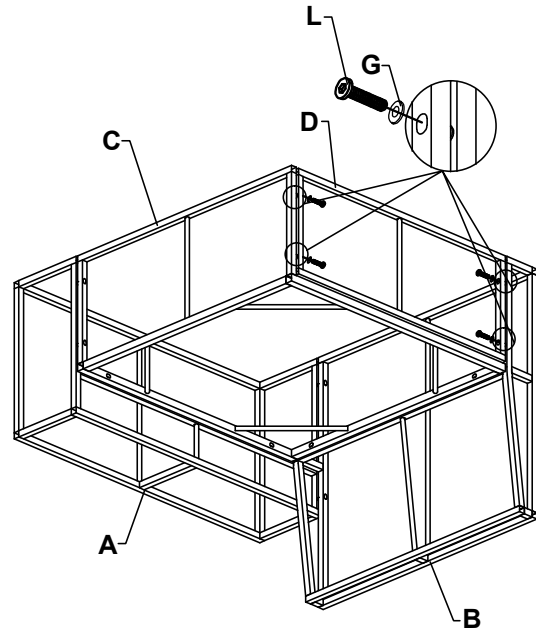



**4**

Flip the assembly back then place the seat cushion on it.

Tips: Do not tighten all screws fully before the item is well assembled.

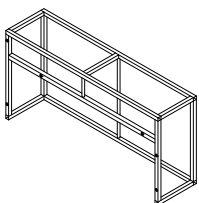
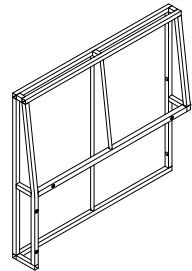
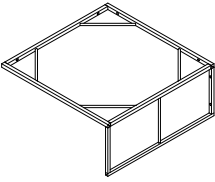
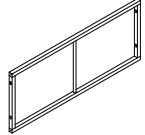
F06L572&F06L573&F06L574

Left End Seat

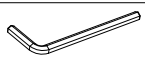
Item no.	Reference Image	Description	Qty.
A		Left Arm Rest	1
B		Seat Back	1
C		Seat Base	1
D		Side Panel	1
K		M6 x 35 Socket Head Cap Screw	4
L		M6 x 30 Socket Head Cap Screw	7
G		Flat Washers	11
I		4-mm Allen Key	1

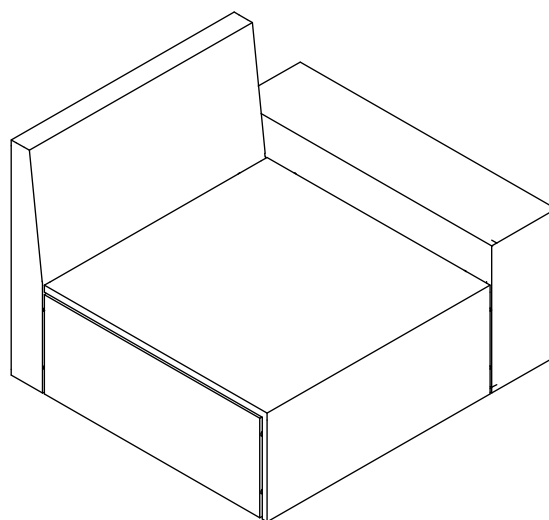

1

Attach the left arm rest (A) and the seat back (B) using a M6 x 30 socket head cap screw (L) with a flat washer (G). Do this in two places.

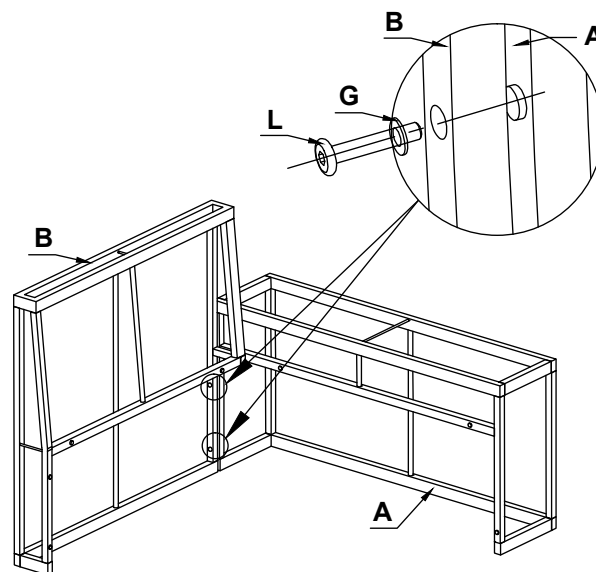

2

Flip the assembly upside down. Attach the seat base (C) to the assembly (A/B) using a M6 x 30 socket head cap screw (L) with a flat washer (G).

Secure the side and back holes with M6 x 35 socket head cap screws (K) with flat washers (G). Do this in four places.

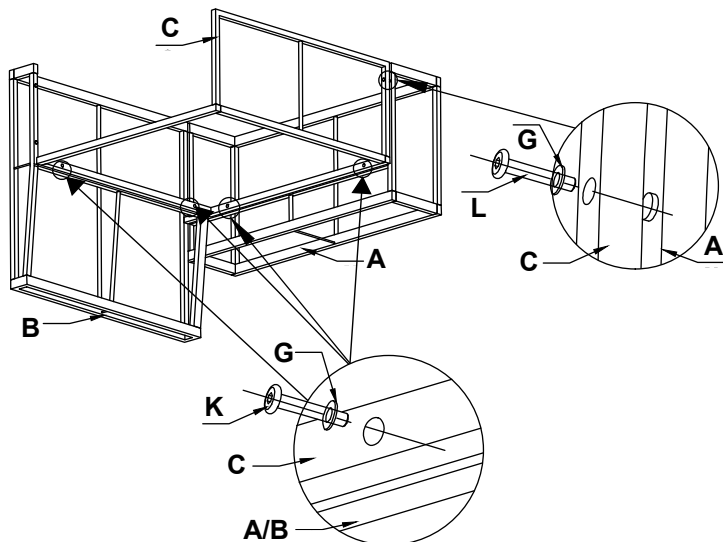

F06L572&F06L573&F06L574**Left End Seat****3**

With the assembly still flipped over, attach the side panel frame (D) using M6 x 30 socket head cap screws (L) with flat washers (G). Do this in four places.

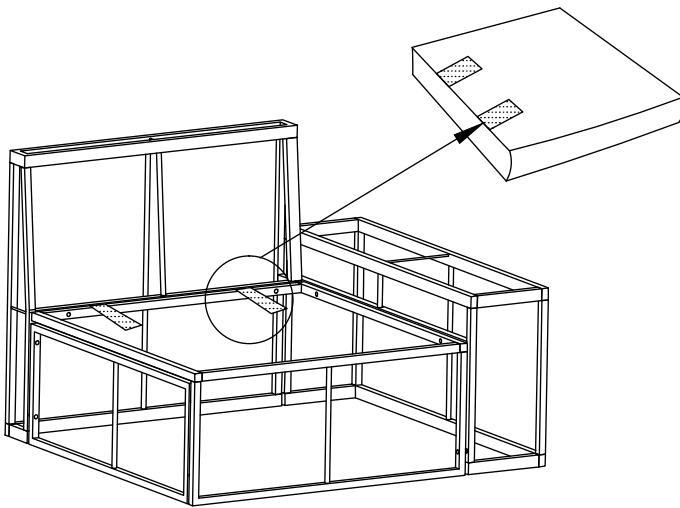
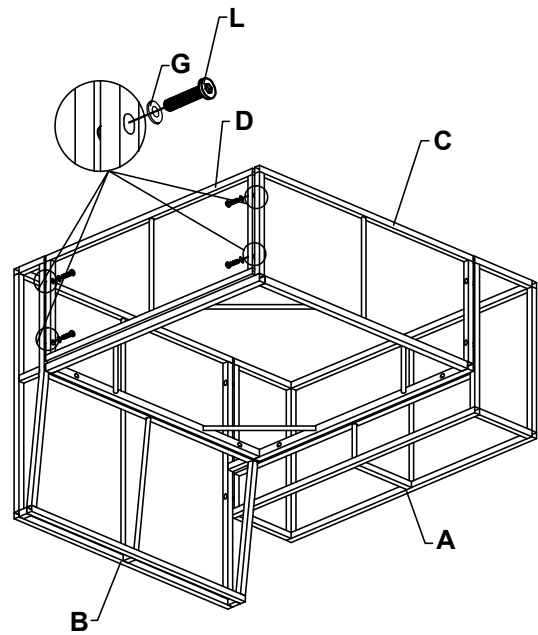



**4**

Flip the assembly back then place the seat cushion on it.

Tips: Do not tighten all screws fully before the item is well assembled.

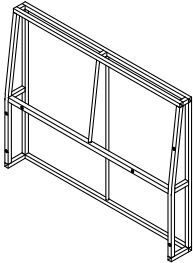
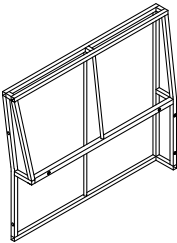
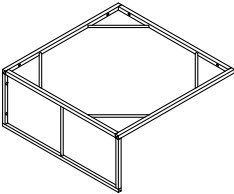
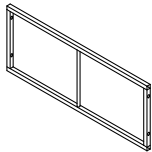
F06L572&F06L573&F06L574

Corner Seat

Item no.	Reference Image	Description	Qty.
A		Right Seat Back	1
B		Left Seat Back	1
C		Seat Base	1
D		Side Panel	1
K		M6 x 35 Socket Head Cap Screw	4
L		M6 x 30 Socket Head Cap Screw	7
G		Flat Washers	11
I		4-mm Allen Key	1

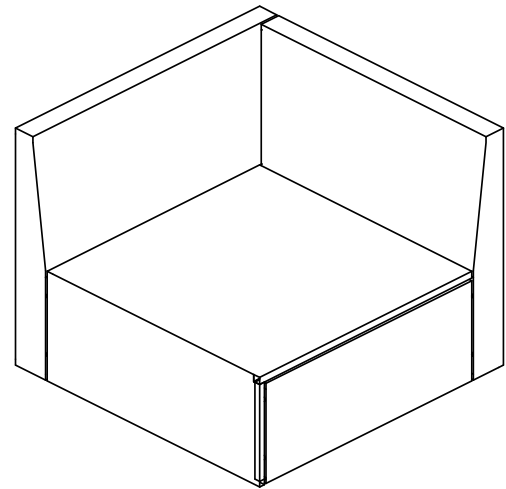

1

Attach the right seat back (A) and the left seat back (B) using a M6 x 30 socket head cap screw (L) with a flat washer (G). Do this in two places.

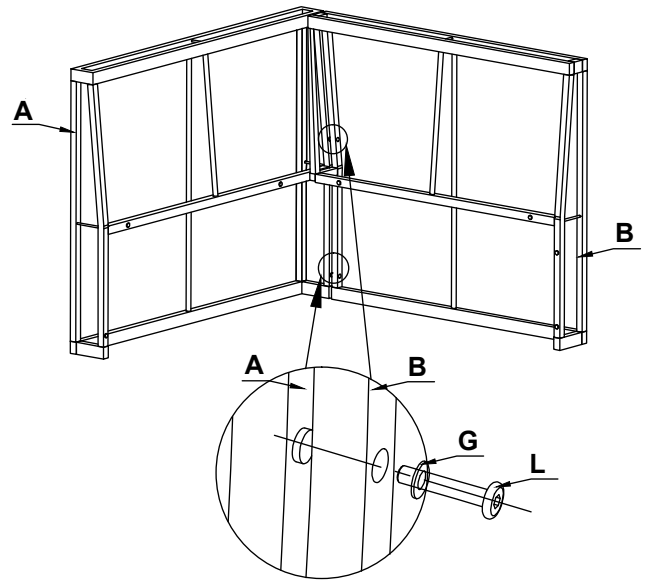

2

Flip the assembly upside down. Attach the seat base (C) to the assembly using M6 x 35 socket head cap screws (K) with flat washers (G). Do this in four places.

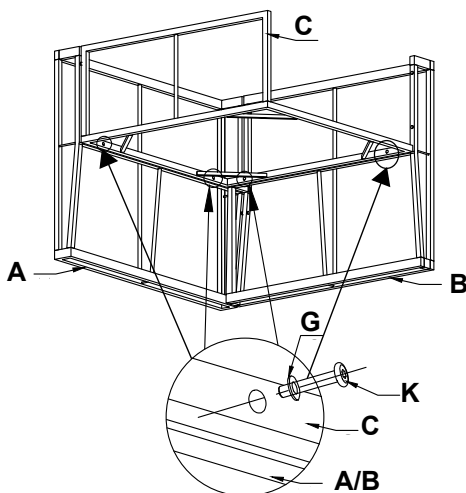

F06L572&F06L573&F06L574**Corner Seat****3**

With the assembly still flipped over, attach the side panel frame (D) using M6 x 30 socket head cap screws (L) with flat washers (G). Do this in four places.

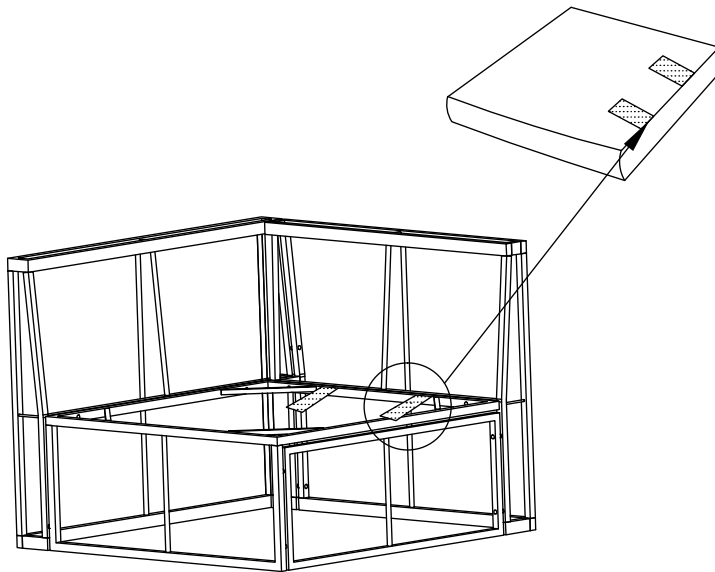
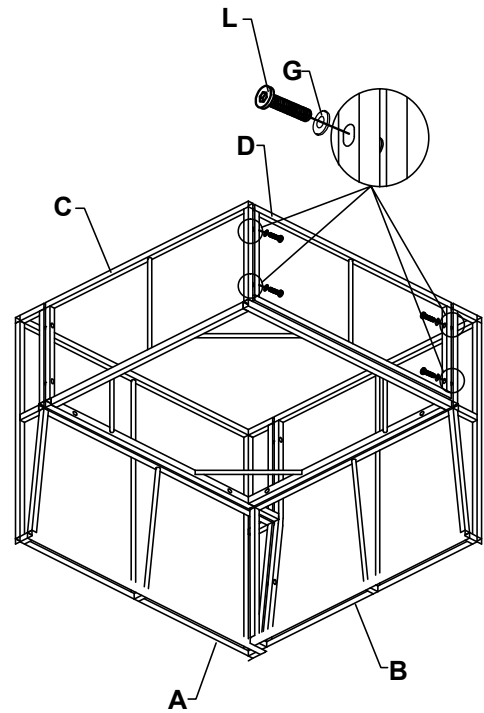
**4**

Flip the assembly back then place the seat cushion on it.

Tips: Do not tighten all screws fully before the item is well assembled.

F06L572&F06L573&F06L574

Middle Seat

(DO THIS TWO TIMES)

Item no.	Reference Image	Description	Qty.
A		Seat Back	1
B		Seat Base	1
C		Side Panel	2
K		M6 x 35 Socket Head Cap Screw	2
L		M6 x 30 Socket Head Cap Screw	8
G		Flat Washers	10
I		4-mm Allen Key	1

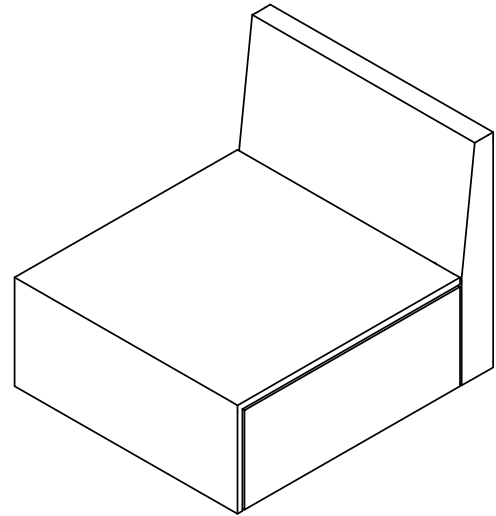

1

Flip the assembly upside down. Attach the seat back (A) and the seat base (B) using M6 x 35 socket head cap screws (K) with flat washers (G). Do this in two places.

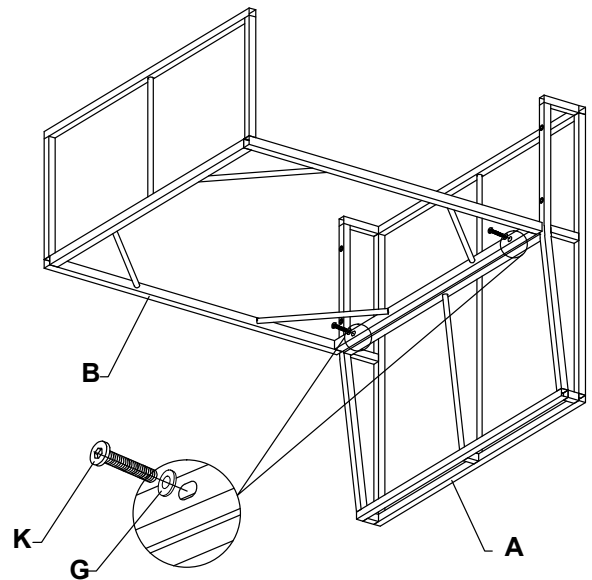

2

With the assembly still flipped over, attach the side panels (C) to the assembly using M6 x 30 socket head cap screws (L) with flat washers (G). Do this in eight places.

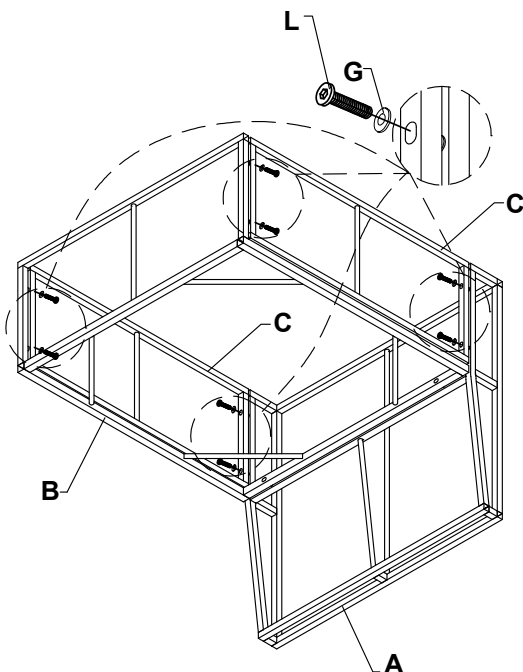

F06L572&F06L573&F06L574
Middle Seat
(DO THIS TWO TIMES)





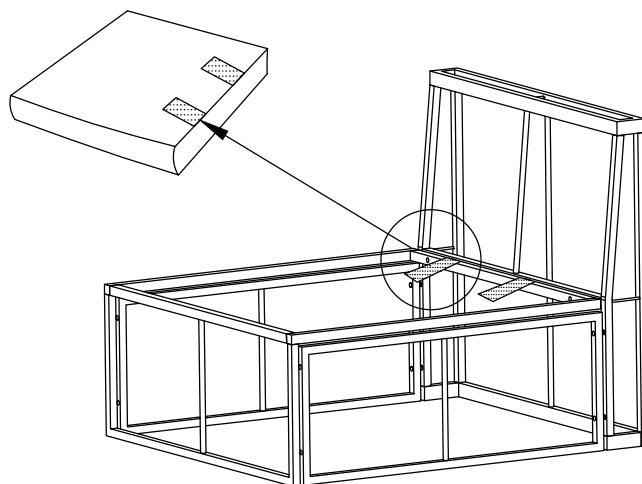

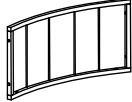
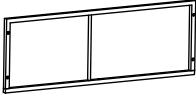
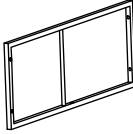

3

Flip the assembly back then place the seat cushion on it.



Tips:Do not tighten all screws fully before the item is well assembled.

F06L572&F06L573&F06L574 Coffee Table

Item no.	Reference Image	Description	Qty.
A		Table Base	1
B		Back Panel Frame	2
C		Right Side Panel	1
D		Left Side Panel	1
L	 M6*30	M6 x 30 Socket Head Cap Screw	12
F	 M6*45	M6 x 45 Socket Head Cap Screw	2
G	 Φ 13*Φ 6.5*1	Flat Washer	16
H	 M6	Nut	2
I	 S=4	4-mm Allen Key	1
J	 S=10	Wrench	1
M		Glass Top	1

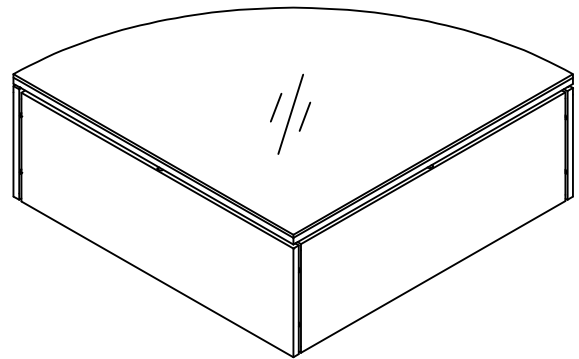

1

Attach the two back panels (B) using M6 x 45 socket head cap screws (F) with flat washers (G) and secure it with a washer (G) and a nut (H). Do this in two places.

Flip the assembly upside down. Secure the back panel assembly to the table base (A) using M6 x 30 socket head cap screws (L) with flat washers (G). Do this in four places.

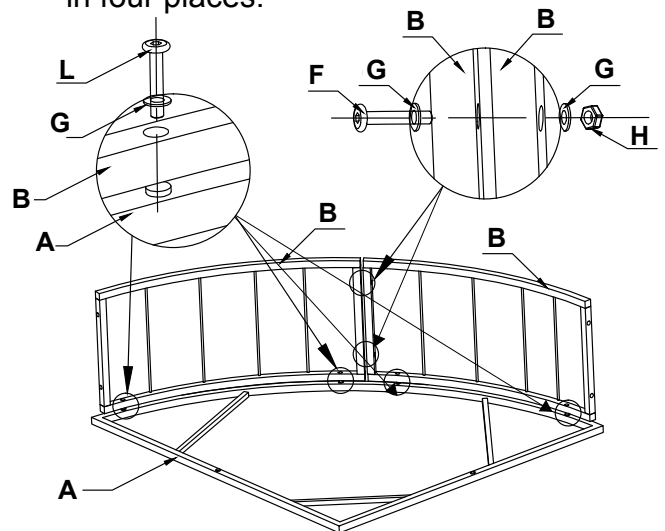

2

With the assembly still flipped over, attach the right side panel (C) using M6 x 30 socket head cap screws (L) with flat washers (G). Do this in three places.

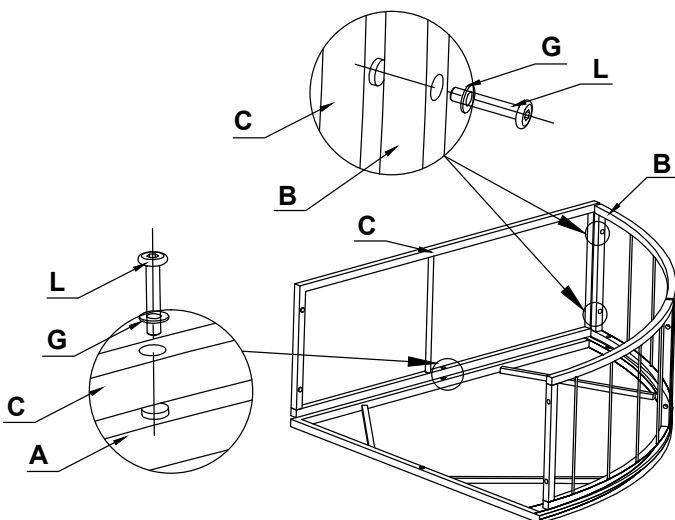

F06L572&F06L573&F06L574

Coffee Table

3

With the assembly still flipped over, attach the left side panel (D) using M6 x 30 socket head cap screws (L) with flat washers (G) to the table base (A). Attach the left side panel (D) using M6 x 30 socket head cap screws (L) with flat washers (G) to the front panel (B) and right side panel (C). Do this in five places.

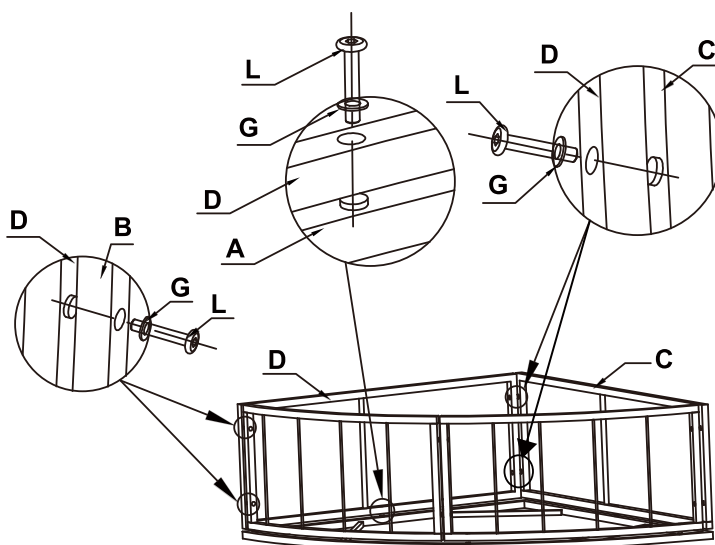

Tips: Do not tighten all screws fully before the item is well assembled.

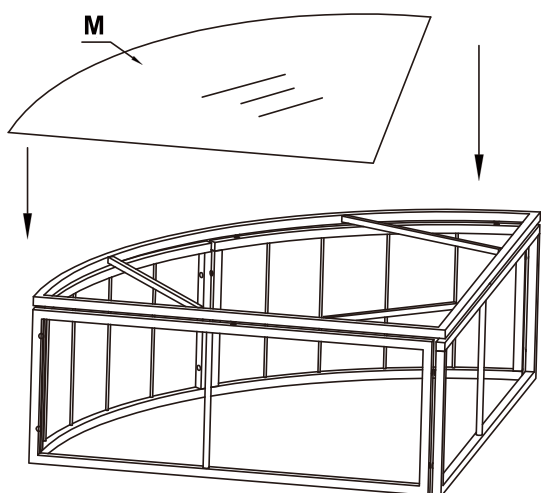

4

Flip the assembly back then place the glass top (M) on it.

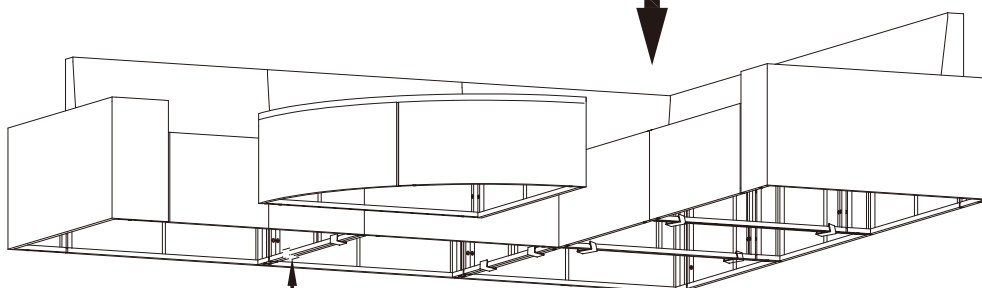
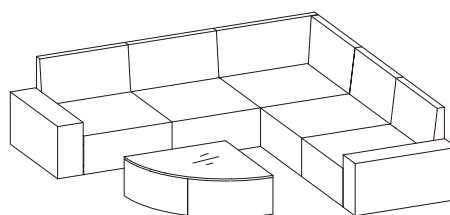

8PCS

After finishing all assembling, please use plastic clips to connect each sofa.