

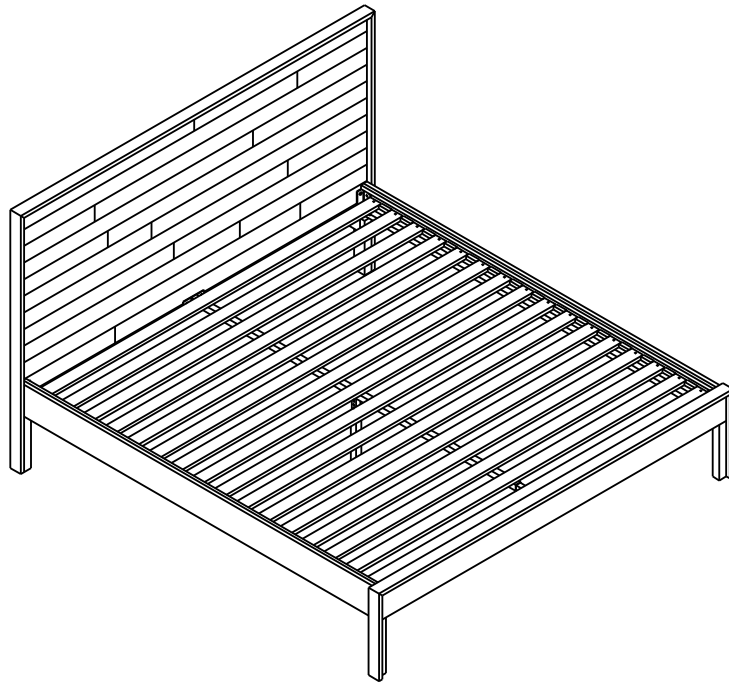





ASSEMBLY INSTRUCTIONS.













THANK YOU FOR YOUR PURCHASE!

PARTS AND HARDWARE.

PARTS LIST

NO.	DESCRIPTION	IMAGE	Q'TY
P1	HEAD BOARD		1
P2	FOOT BOARD		1
P3	SIDE RAIL		2
P4	CENTER RAIL		1
P5	SLATS		16

HARDWARE LIST

No.	DESCRIPTION	IMAGE	QTY
H1	BOLT M10x60		6
H2	FLAT WASHER M10		12
H3	HEX NUT M10		6
H4	SPANNER 17MM		1
H5	BOLT M10x30		6
H6	SCREW		32
H7	SPRING WASHER		12
H8	BOLT M8x20		1
H9	BOLT M8x40		1
H10	NUT M8		1
H11	SPANNER 13MM		1

NOTES.

Thank you for purchasing this quality product! Be sure to check all packing material carefully for small part that may have come loose inside the carton during shipping.

CAUTION: The item is heavy, assembly should be performed by two people.

STEP 1.

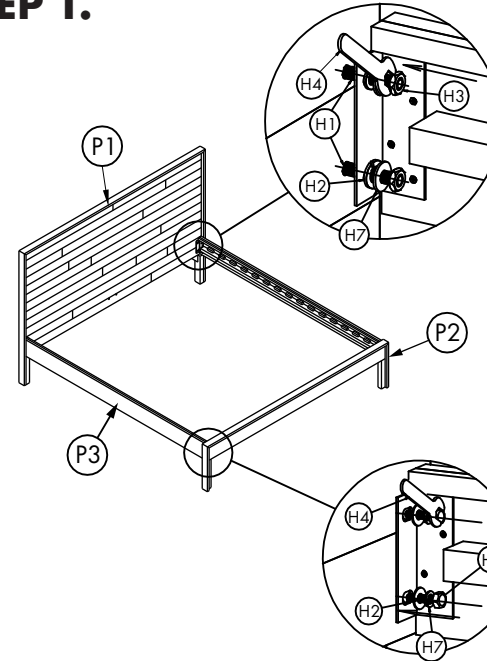

STEP 2.

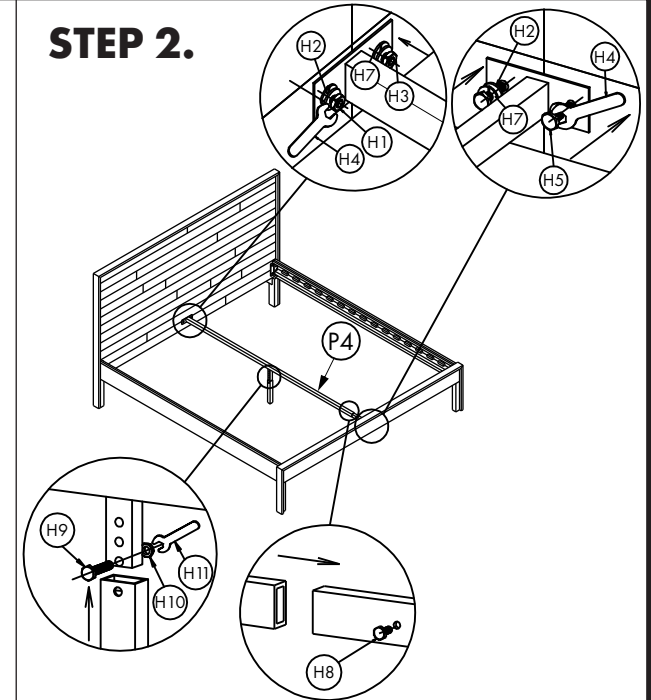

STEP 3.

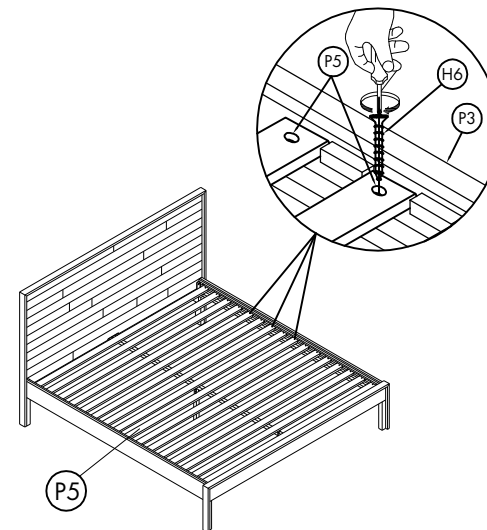

STEP 4.

