

# ASSEMBLY INSTRUCTIONS

## COUNTER TABLE COUNTER CHAIR (SET INCLUDES 4 CHAIRS)

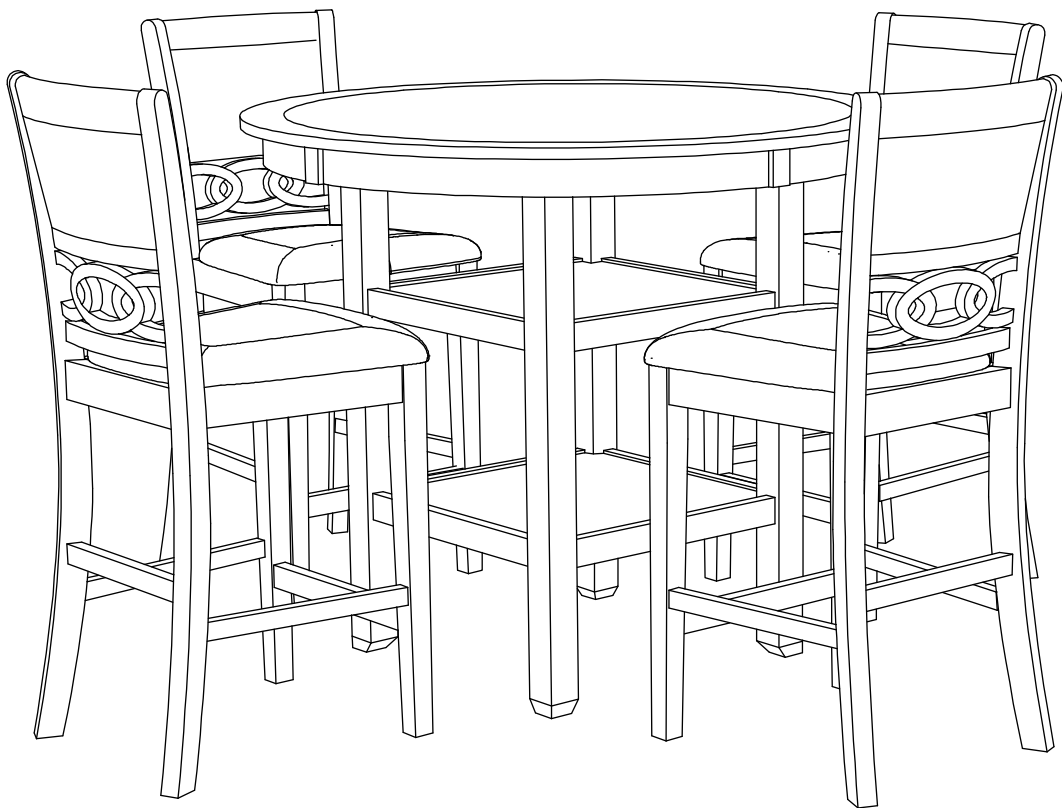

This page lists all the contents included in the Box. Please take time to identify the hardware as well as the individual components to this product. As you unpack and prepare for assembly, place the contents on a carpeted or padded area to protect them from damage.

### Cleaning & Care

Treat the surface with care, clean it with a dry or damp soft cloth.  
Do not use abrasive cleaners. Hardware may be loosen over time.  
Periodically check that all connections are tight.  
A Phillips screwdriver is necessary for assembly.

## GENERAL INFORMATION, TIPS & TRICKS

1. Please read the assembly instructions prior to assembling this product.
2. To avoid damages, assemble this product on a non-abrasive surface such as a carpet.
3. Make sure all bolts and nuts are tightly fastened before the product is used.
4. Not for commercial use.
5. Care: Wipe with a damp cloth. Use furniture polish or lemon oil on the wood as needed. Avoid prolonged exposure to moisture.

---

Please make sure you have all parts before beginning assembly. Please wait until all steps are completed before tightening bolts. We recommend two people to assemble.

---

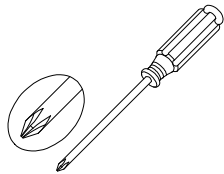

A Phillips screwdriver is necessary for assembly.



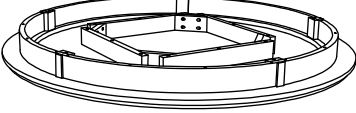
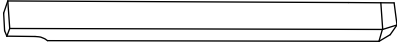
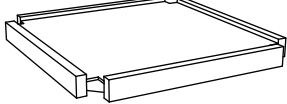

---

Do not put hot pots or objects which are more than 80 degrees Fahrenheit directly on the table.

## TABLE PART LIST

A. Table Top	B. Table Legs	C. Table Shelves
		
QTY: 1 PC	QTY: 4 PCS	QTY: 2 PCS

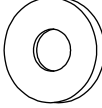
## TABLE HARDWARE LIST

1. ALLEN BOLTS	2. SPRING WASHERS	3. FLAT WASHERS	4. ALLEN WRENCH
			
SIZE: 5/16" x 2 1/2"	SIZE: 5/16" DIA	SIZE: 5/16" DIA	SIZE: 1/4" DIA
QTY: 12 PCS	QTY: 12 PCS	QTY: 12 PCS	QTY: 1 PC

# TABLE ASSEMBLY INSTRUCTIONS

## STEP 1

Attach the Table Shelves (C) to the Table Legs (B) by using Allen Bolts (1), Spring Washers (2) and Flat Washers (3). Do not tighten all bolts at this step.

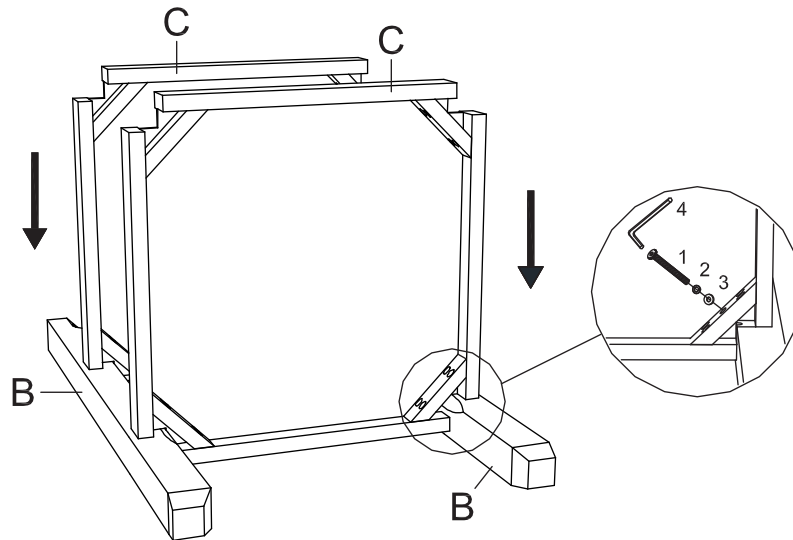

## STEP 2

Attach the Table Legs (B) to the Table Shelves (C) by using Allen Bolts (1), Spring Washers (2) and Flat Washers (3). Do not tighten all bolts at this step.

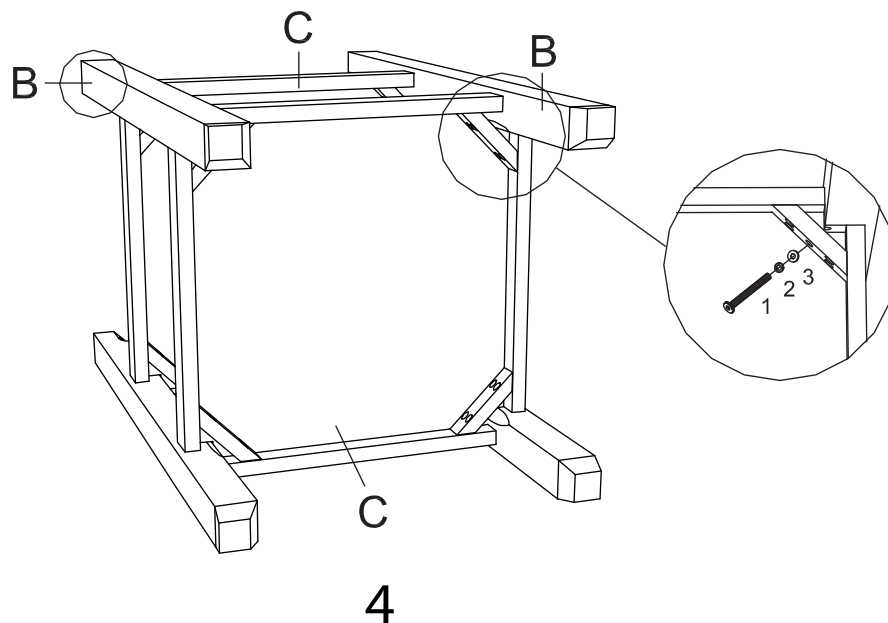

# TABLE ASSEMBLY INSTRUCTIONS

## STEP 3

Turn the assembly upright. Place the Table Top (A) down to the assembly unit as shown. Ensure the Table Legs (B) are secured to the Table Top (A)

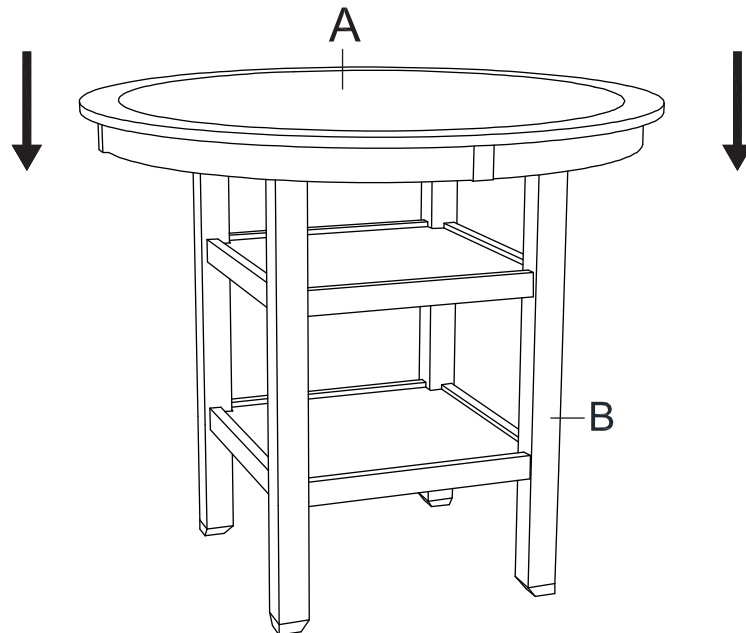



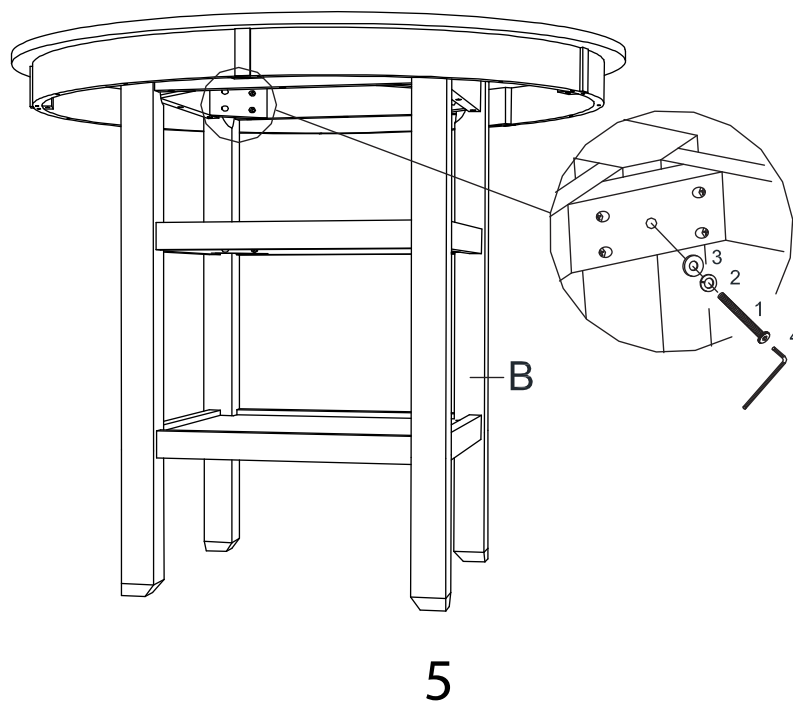

## STEP 4



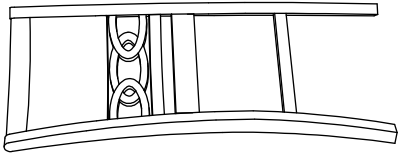
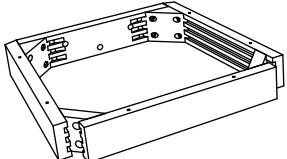

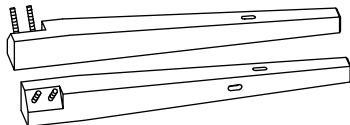
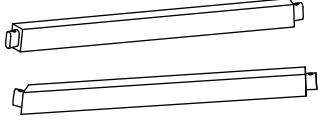
Attach the Table Legs (B) to the Table Top (A) using Allen Bolts (1), Spring Washers (2) and Flat Washers (3). Make sure the table is level, and tighten all bolts by using Allen Wrench (4).

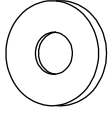

# CHAIR PART LIST

A. Back Legs	B. Seat Frames	C. Cushion Seats
		
QTY: 4 PCS	QTY: 4 PCS	QTY: 4 PCS
D. Front Legs(Left - Right)	E. Side Stretchers (Left - Right)	F. Front Stretchers
		
QTY: 8 PCS	QTY: 8 PCS	QTY: 4 PCS

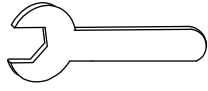
# CHAIR HARDWARE LIST

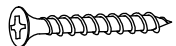
1. FLAT WASHERS	2. SPRING WASHERS	3. NUTS	4. ALLEN WRENCH
			
SIZE: 5/16" DIA	SIZE: 5/16" DIA	SIZE: 5/16" DIA	SIZE: 5/16" DIA
QTY: 44 PCS	QTY: 44 PCS	QTY: 16 PCS	QTY: 1 PC
5. SHORT BOLTS	6. LONG BOLTS	7. WOOD SCREWS	
			
SIZE: 1/4" x 1 3/4"	SIZE: 1/4" x 3"	SIZE: #8 x 1 1/2" L	
QTY: 12 PCS	QTY: 16 PCS	QTY: 48 PCS	

# CHAIR ASSEMBLY INSTRUCTIONS

## STEP 1

Put the Back Leg (A) and the Seat Frame (B) upside down on the soft and smooth surface. Then insert Long Bolts (6), Short Bolts (5), Spring Washers (2), and Flat Washers (1) into the predrilled holes of each corner, by using Allen Wrench (4).

Take the Allen Wrench, and turn the bolts until the legs are secure. **DO NOT TIGHTEN COMPLETELY.** Stop when you feel you are adding force to tighten the bolts.

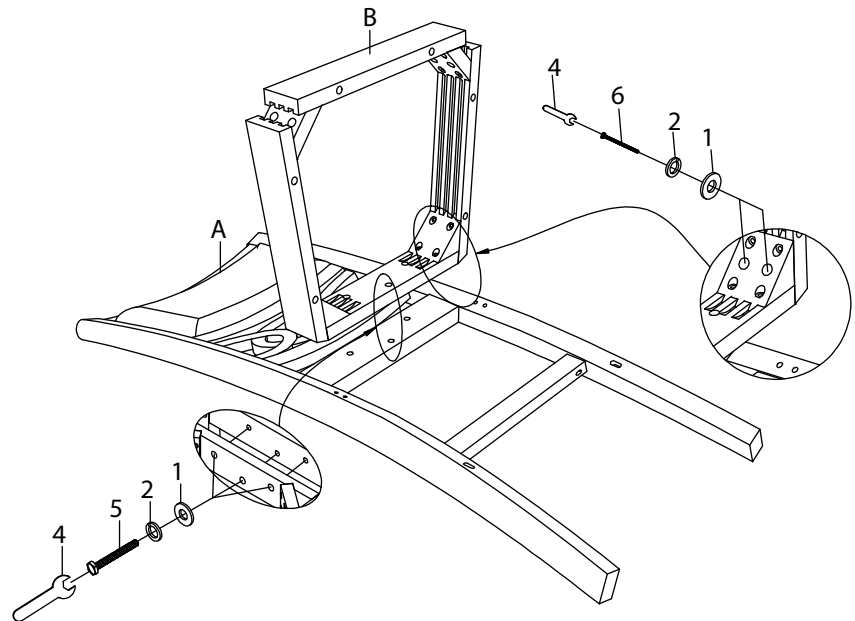

## STEP 2

Insert Side Stretchers (E) into the holes of the Back Leg(A) with Wood Screws (7) by using Screwdriver (not included). Do not fully tighten all screws in this step.

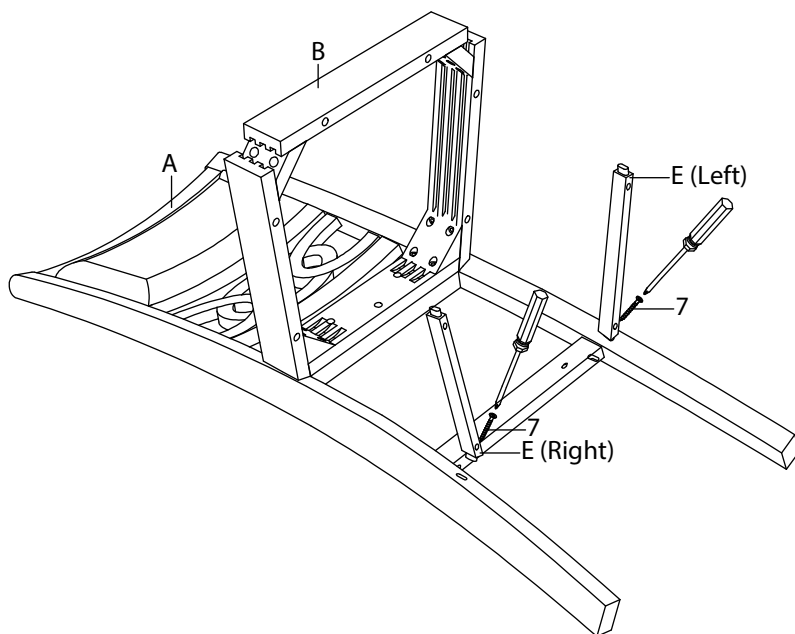

# CHAIR ASSEMBLY INSTRUCTIONS

## STEP 3

First, insert the Front Stretcher (F) into the holes of the Front Legs (D) by using Wood Screws (7). Attach the Front Legs (D) to the Side Stretchers (E) and the corner of Seat Frame (B). Insert Flat Washers (1), Spring Washers (2), and Nuts (3), by using Allen Wrench (4). Tighten all Wood Screws (7) in this step.

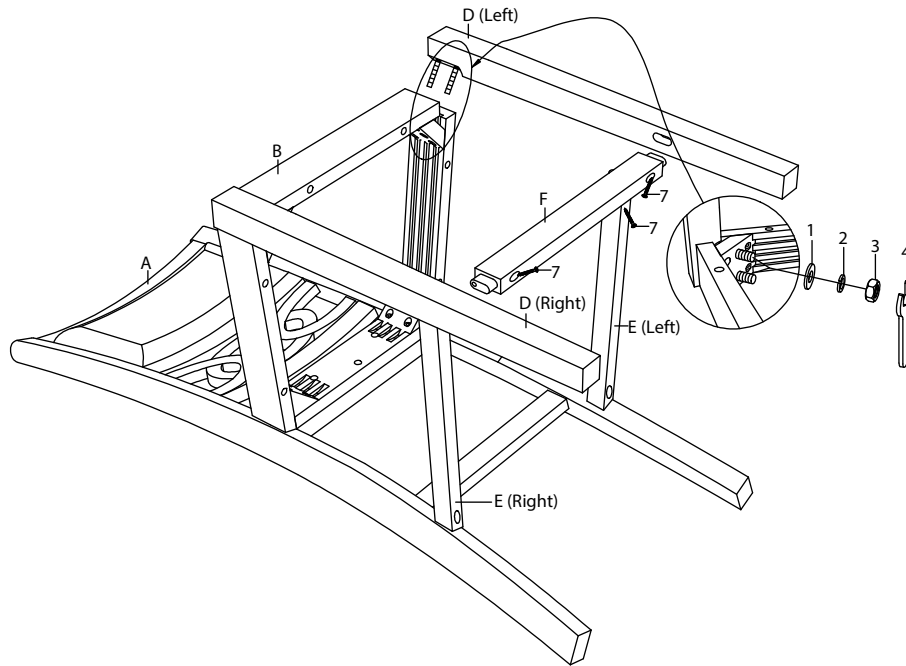

## STEP 4

Attach the Cushion Seat (C) onto the Seat Frame (B) with Wood Screws (7) by using Screwdriver (not included).

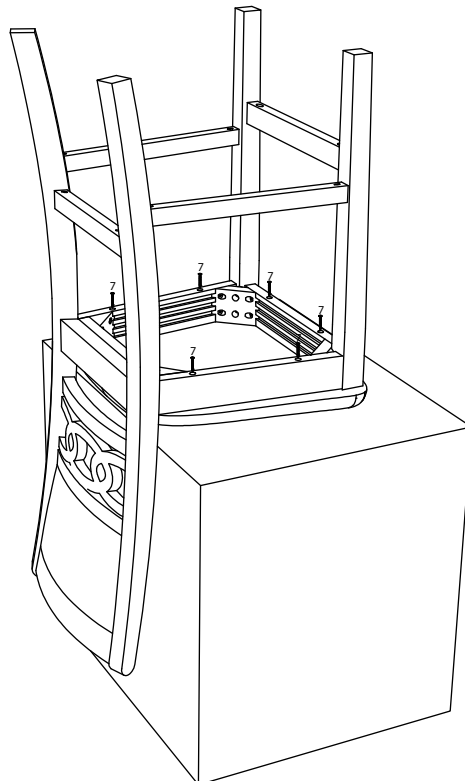

# CHAIR ASSEMBLY INSTRUCTIONS

## STEP 5

Turn the assembled chair to the upright position carefully. Make sure the chair is level, and then securely tighten all bolts at this stage. Assembly is now completed.

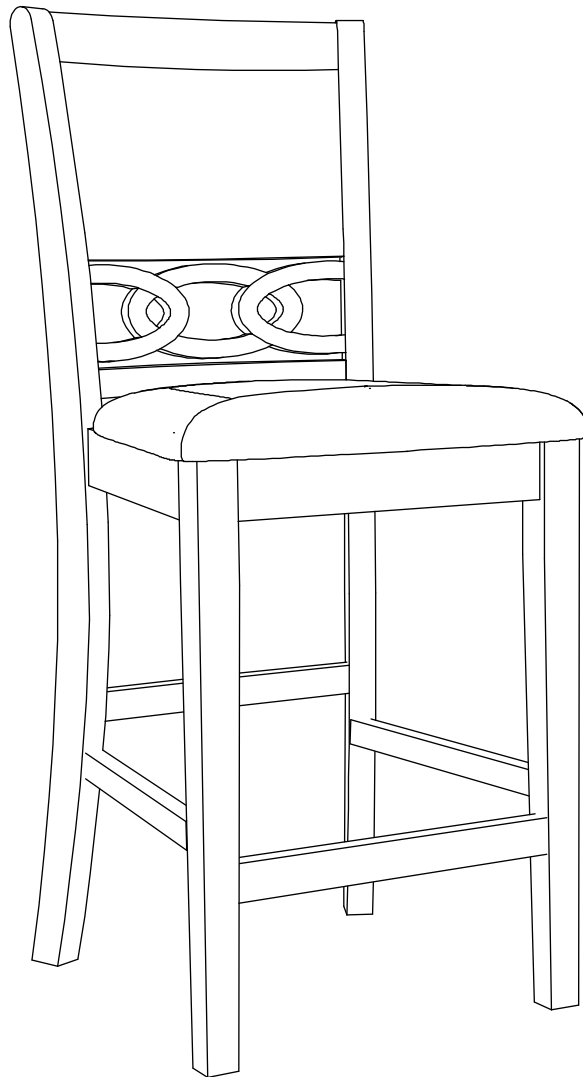

Printed in Vietnam