

READ AND SAVE THIS INSTRUCTIONS FOR USE

**AMG005158-US**

# ASSEMBLY & INSTRUCTION MANUAL

MADE IN CHINA

# Before You Start

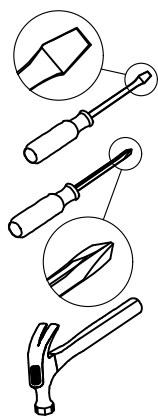

- ✓ Read through each step carefully and follow the proper order
- ✓ Separate and count all your parts and hardware
- ✓ Give yourself enough room for the assembly process
- ✓ Have the following tools: Flat Head Screwdriver, #2 Phillips Head Screwdriver and Hammer
- ✓ Caution: If using a power drill or power screwdriver for screwing, please be aware of to slow down and stop when screw is tight. Failure to do so may result in stripping the screw. (Assembly speed can be increased by using electric screwdriver)

# Helpful Hints

## PEOPLE NEEDED FOR ASSEMBLY: 1-2

- Open your item in the area you plan to keep it to avoid excessive heavy lifting.
- Identify, sort and count the parts before attempting assembly.
- Compression dowels are lightly tapped in with a hammer.
- Slides are labeled with an **R** (right) and **L** (left) for proper placement.
- Make sure to always face the point on the top of the Cam Lock towards the outer edge.
- If there is a back panel in the package, please install it to make sure your unit is complete and sturdy.
- Please fix all the screws provided for the back panel which can enhance product stability. If it is difficult to fix it when tightening, it can be fixed with the help of a hammer and then tightened.
- Do NOT use harsh chemicals or abrasive cleaners on this item.
- Never push, pull, or drag your furniture.

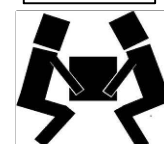
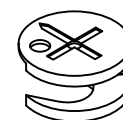



---

# Board Identification

Not actual size

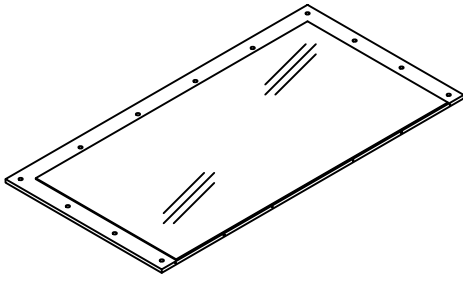

(A)

DRESSING MIRROR

Qty:1

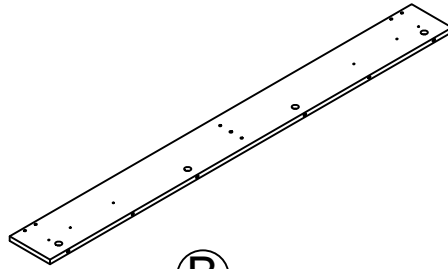

(B)

TOP PANEL

Qty:1

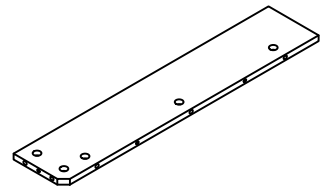

(C)

UPPER PARTITION PANEL

Qty:1

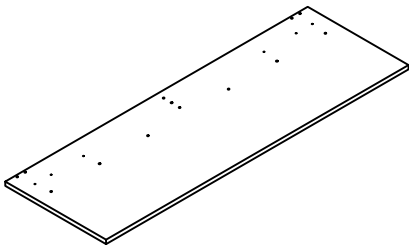

(D)

FRONT PANEL

Qty:1

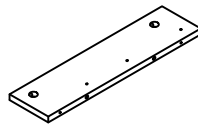

(E)

LOWER PARTITION PANEL

Qty:2

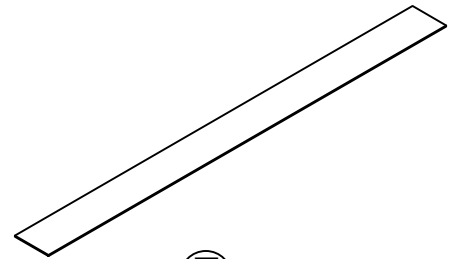

(F)

UPPER BACK PANEL

Qty:1

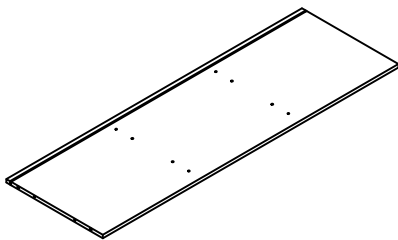

(G)

MIDDLE PANEL

Qty:1

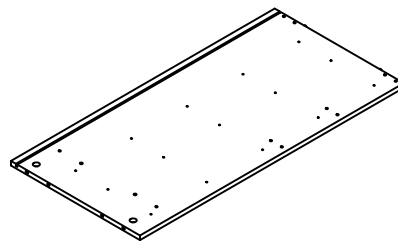

(H)

LOWER LEFT SIDE PANEL

Qty:1

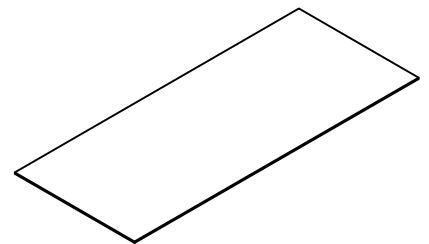

(I)

LOWER LEFT BACK PANEL

Qty:2

---

# Board Identification

Not actual size

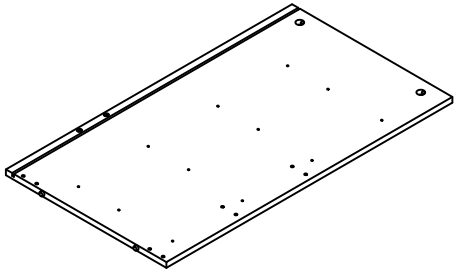

ⓐ

LOWER LEFT PARTITION

Qty:1

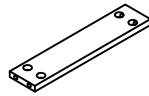

ⓑ

DRAWER SUPPORT RAIL

Qty:4

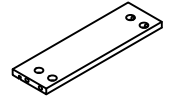

ⓒ

LOWER BACK SLAT

Qty:2

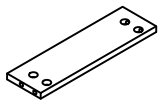

ⓓ

LOWER FRONT SLAT

Qty:2

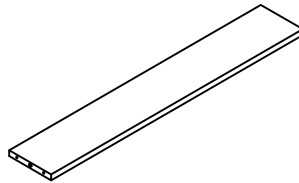

ⓔ

REAR LOWER PANEL

Qty:1

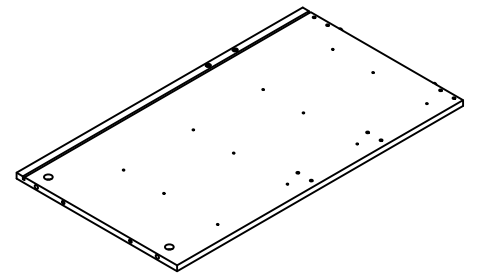

ⓕ

LOWER RIGHT PARTITION

Qty:1

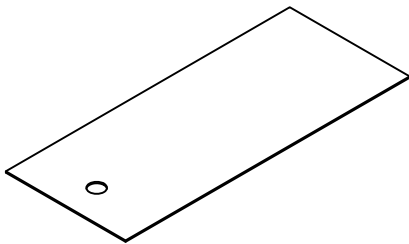

ⓖ

LOWER RIGHT BACK PANEL

Qty:1

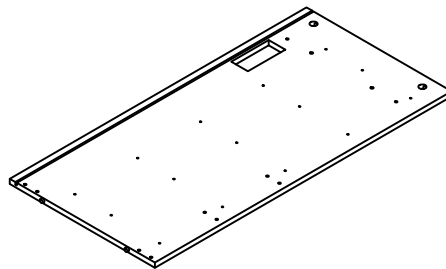

ⓗ

LOWER RIGHT SIDE PANEL

Qty:1

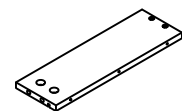

ⓘ

SMALL DRAWER RIGHT

Qty:8

---

# Board Identification

Not actual size

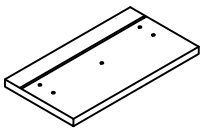

Ⓢ

SMALL DRAWER FRONT

Qty:8

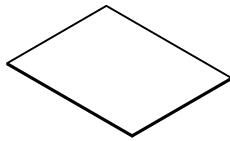

Ⓣ

SMALL DRAWER BOTTOM

Qty:8

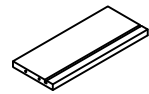

Ⓤ

SMALL DRAWER BACK

Qty:8

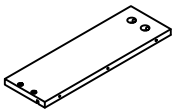

Ⓥ

SMALL DRAWER LEFT

Qty:8

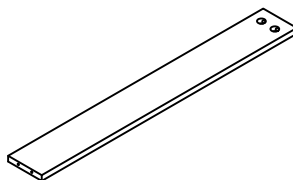

Ⓦ

VERTICAL DRAWER SUPPORT

Qty:2

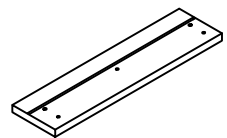

Ⓧ

LEFT BIG DRAWER FRONT

Qty:1

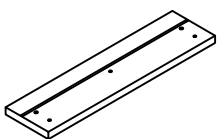

Ⓨ

MIDDLE BIG DRAWER FRONT

Qty:1

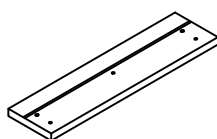

Ⓩ

RIGHT BIG DRAWER FRONT

Qty:1

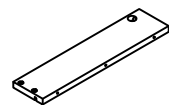

ⓂⓂ

BIG DRAWER LEFT

Qty:3

---

# Board Identification

Not actual size

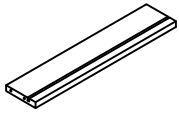

Ⓟ

BIG DRAWER BACK

Qty:3

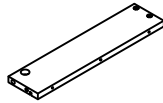

Ⓞ

BIG DRAWER RIGHT

Qty:3

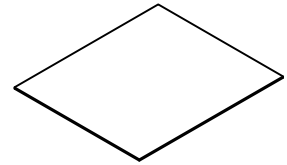

Ⓞ

BIG DRAWER BOTTOM

Qty:3

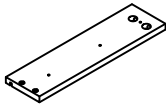

Ⓞ

LEFT VERTICAL DRAWER

Qty:2

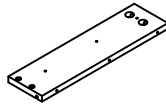

Ⓞ

RIGHT VERTICAL DRAWER

Qty:2

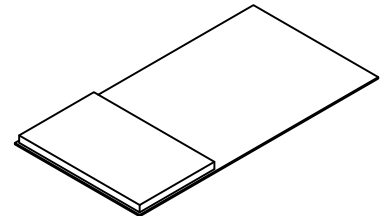

Ⓞ

VERTICAL DRAWER BOTTOM

Qty:2

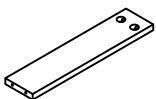

Ⓞ

VERTICAL DRAWER PARTITION

Qty:4

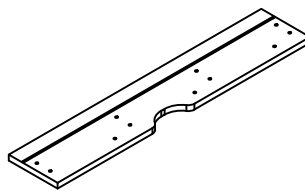

Ⓞ

LEFT VERTICAL  
DRAWER FRONT

Qty:1

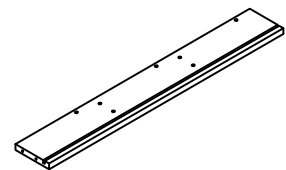

Ⓞ

LEFT VERTICAL  
DRAWER BACK

Qty:1

# Board Identification

Not actual size

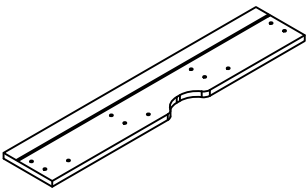

ⓀⓀ

RIGHT VERTICAL  
DRAWER FRONT  
Qty:1

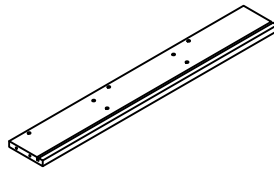

ⓁⓁ

RIGHT VERTICAL  
DRAWER BACK  
Qty:1

## Cam Lock Fastening System

Insert the cam bolt into the hole first, then insert the cam lock and lock it.

1

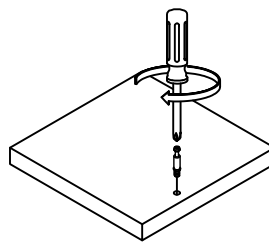

2

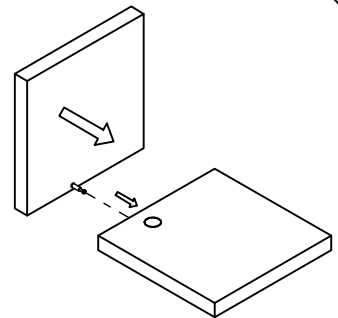

3

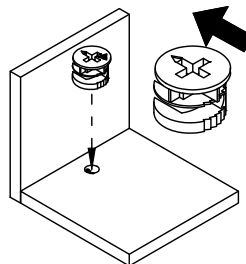

The opening must point toward the edge of the board

4

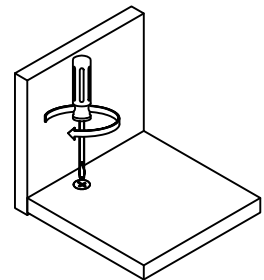

# Part List

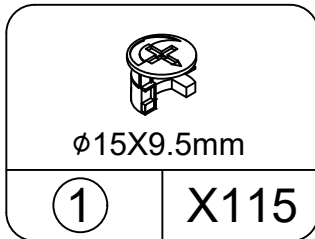

CAM LOCK  
spare: 3

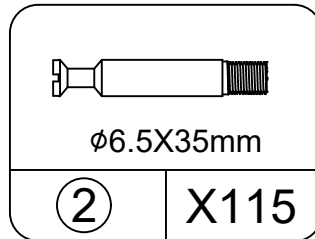

CAM BOLT  
spare: 3

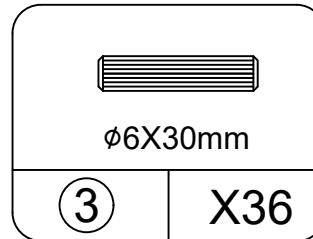

WOOD DOWEL  
spare: 3

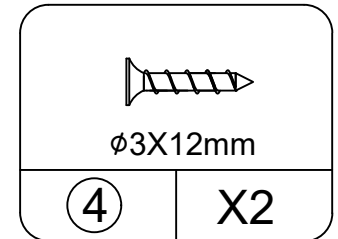

WOOD DOWEL  
spare: 1

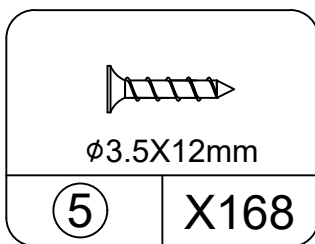

SCREW  
spare: 3

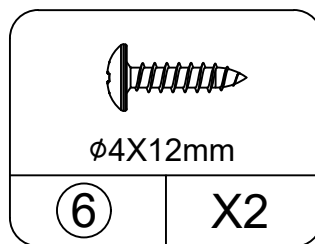

SCREW  
spare: 1

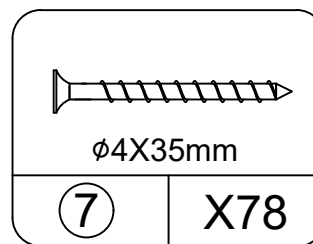

SCREW  
spare: 3

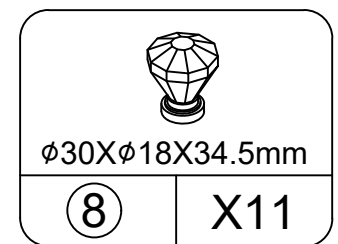

HANDLE  
spare: 1

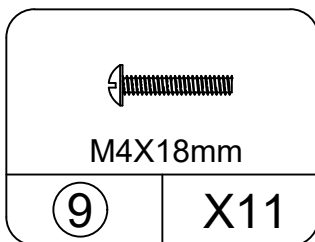

SCREW  
spare: 2

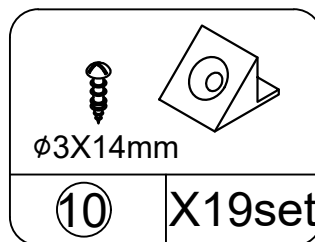

BACK PANEL BUCKLE  
spare: 2

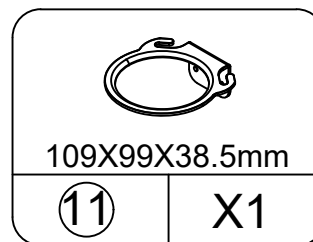

HAIR DRYER RACK

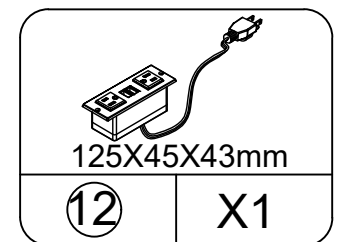

POWER STRIP

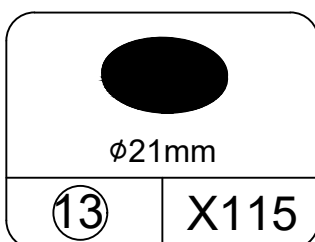

STICKERS FOR  
SCREW HOLES  
spare: 3

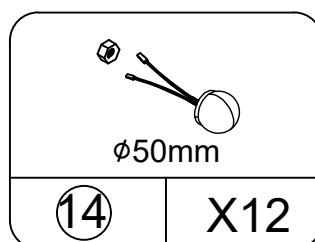

LIGHT BULB

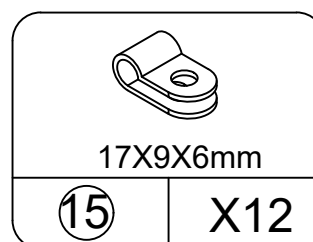

WIRE BUCKLE  
spare: 2

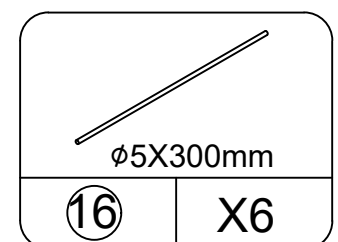

Thin rod

# Part List

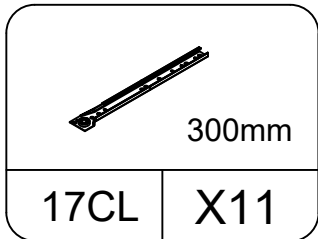

LEFT CABINET MEMBER

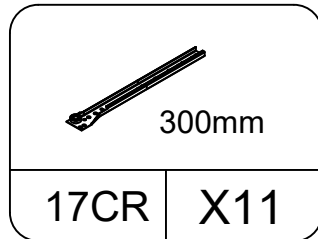

RIGHT CABINET MEMBER

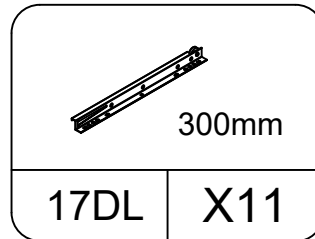

LEFT DRAWER RUNNER

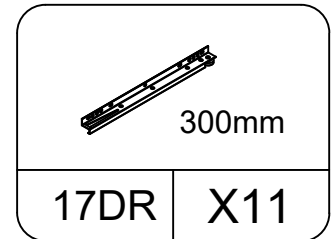

RIGHT DRAWER RUNNER

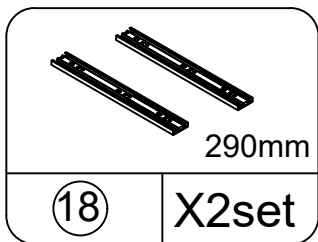

LEFT CABINET MEMBER

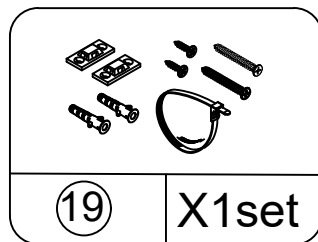

TIPPING RESTRAINT  
HARDWARCE KIT

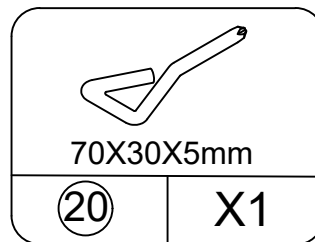

HEX KEY

# STEP1

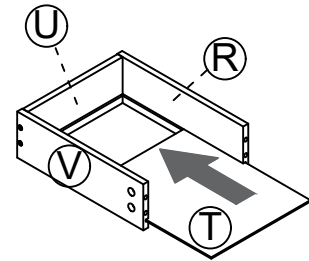
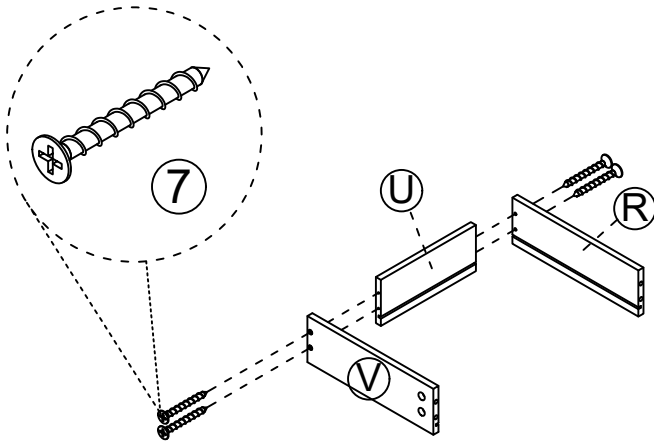
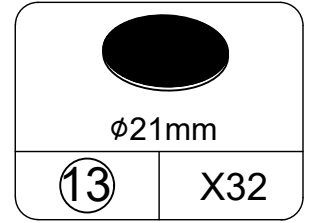
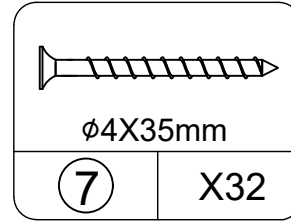
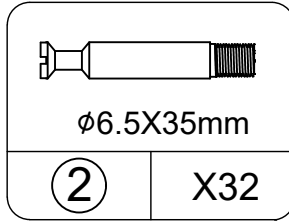
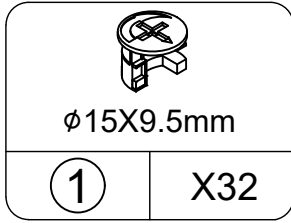
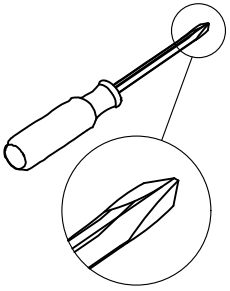

Step 1    Step 2  
Step 4    Step 3

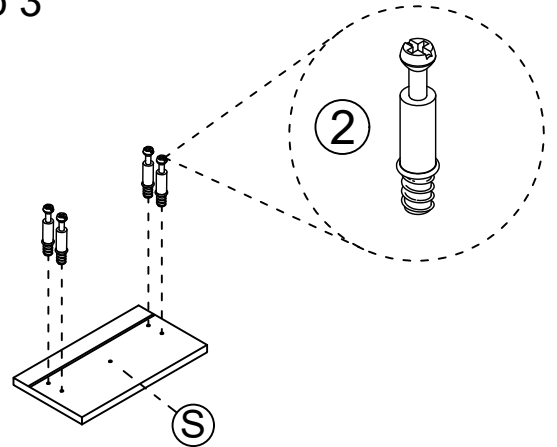
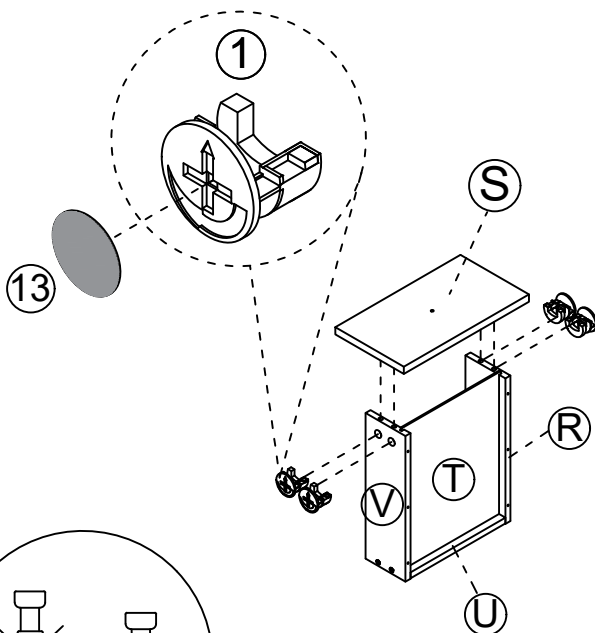

Insert the cam bolt into the hole first, then insert the cam lock and lock it.

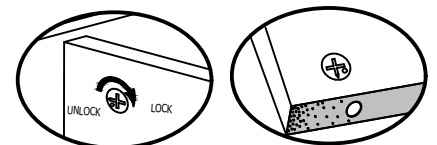
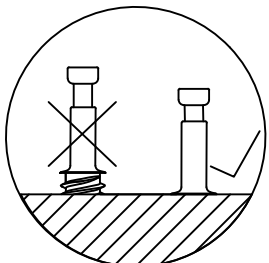

Proper orientation of CAM LOCK

# X8

# STEP 2

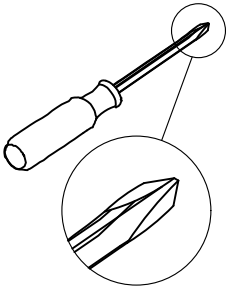

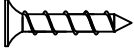
 ø3.5X12mm	
5	X48

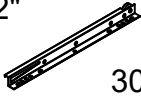
12"  300mm	
17DL	X8

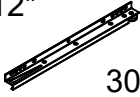
12"  300mm	
17DR	X8

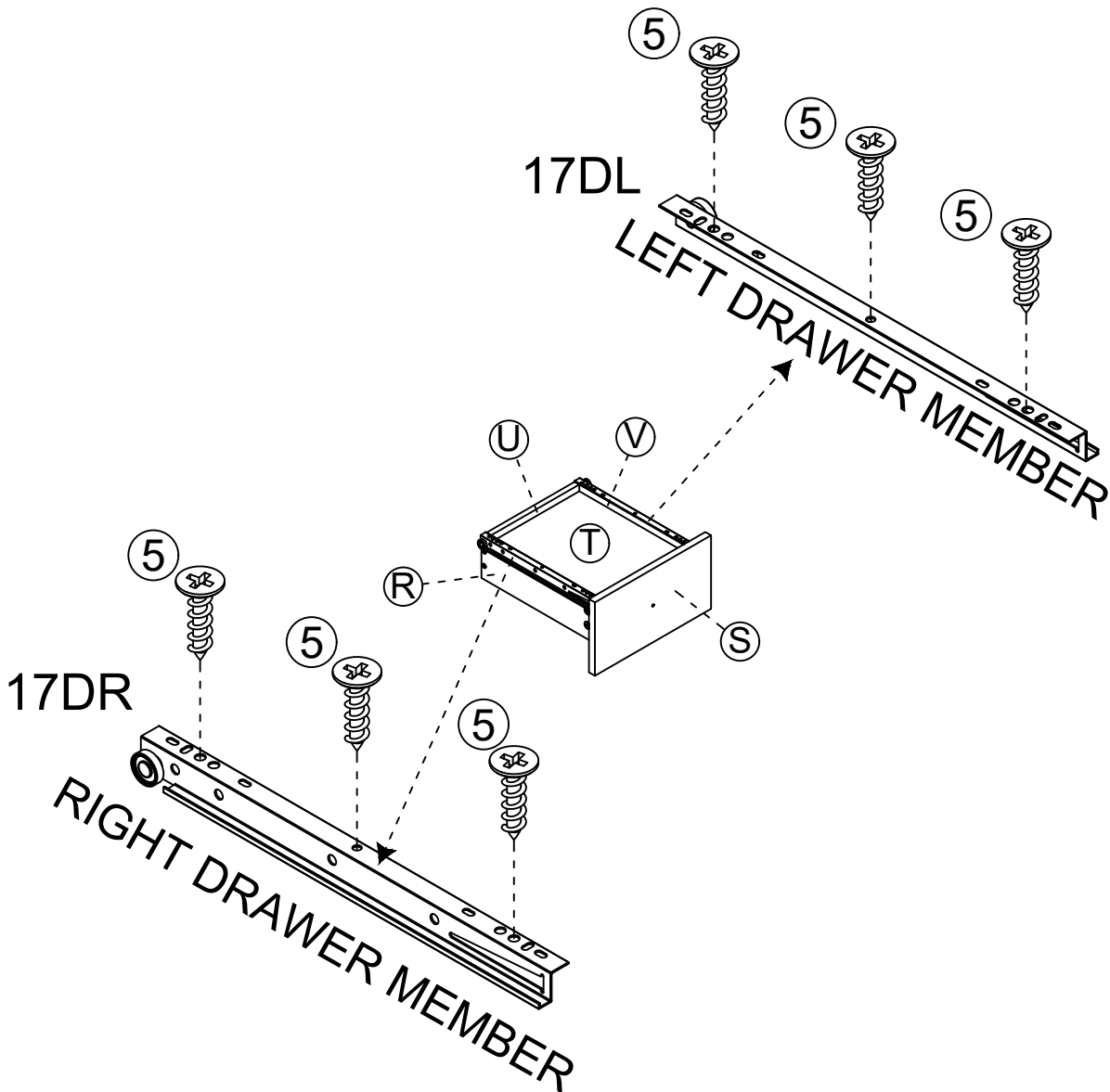

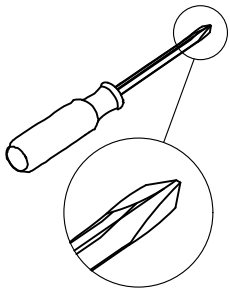

# X8

# STEP3

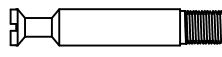

 $\phi 15 \times 9.5 \text{mm}$	
①	X6

 $\phi 6.5 \times 35 \text{mm}$	
②	X6

 $\phi 6 \times 30 \text{mm}$	
③	X6

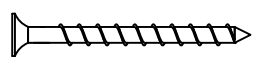
 $\phi 4 \times 35 \text{mm}$	
⑦	X12

 $\phi 21 \text{mm}$	
⑬	X6

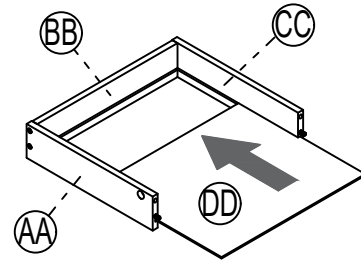
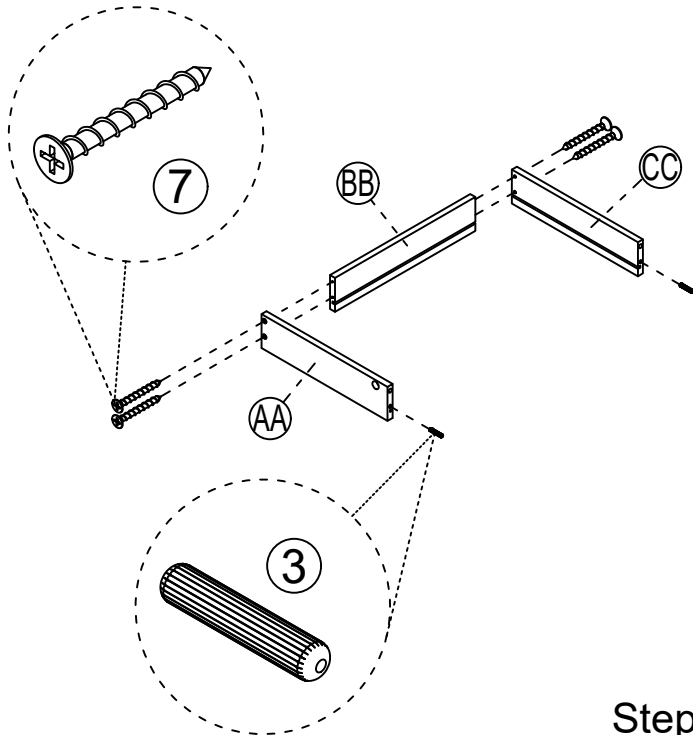

Step 1 Step 2

Step 4 Step 3

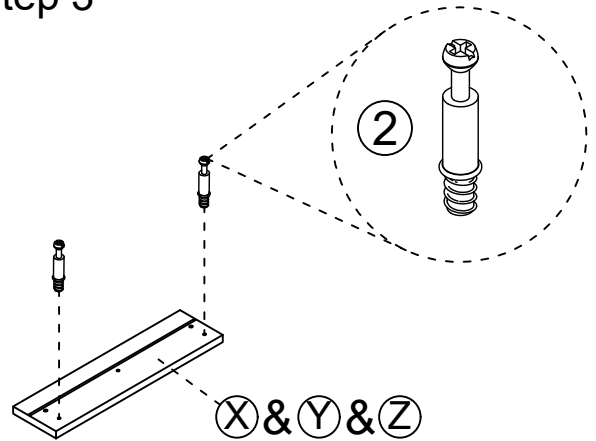
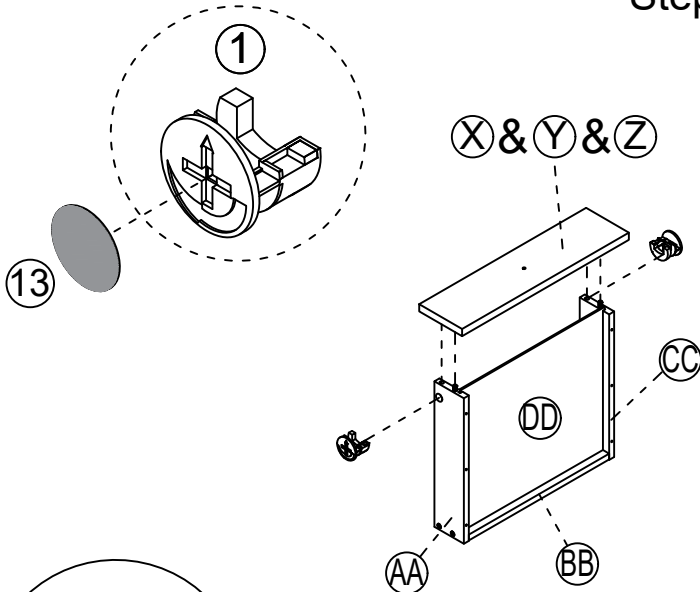

Insert the cam bolt into the hole first, then insert the cam lock and lock it.

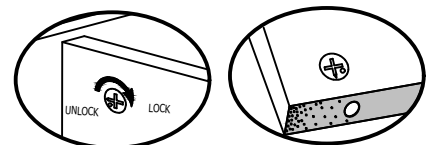
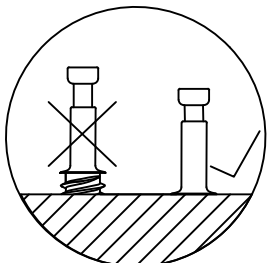

Proper orientation of CAM LOCK

# X3

# STEP 4

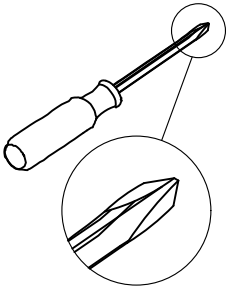

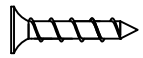
 ø3.5X12mm	
5	X18

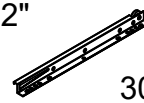
12"  300mm	
17DL	X3

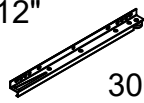
12"  300mm	
17DR	X3

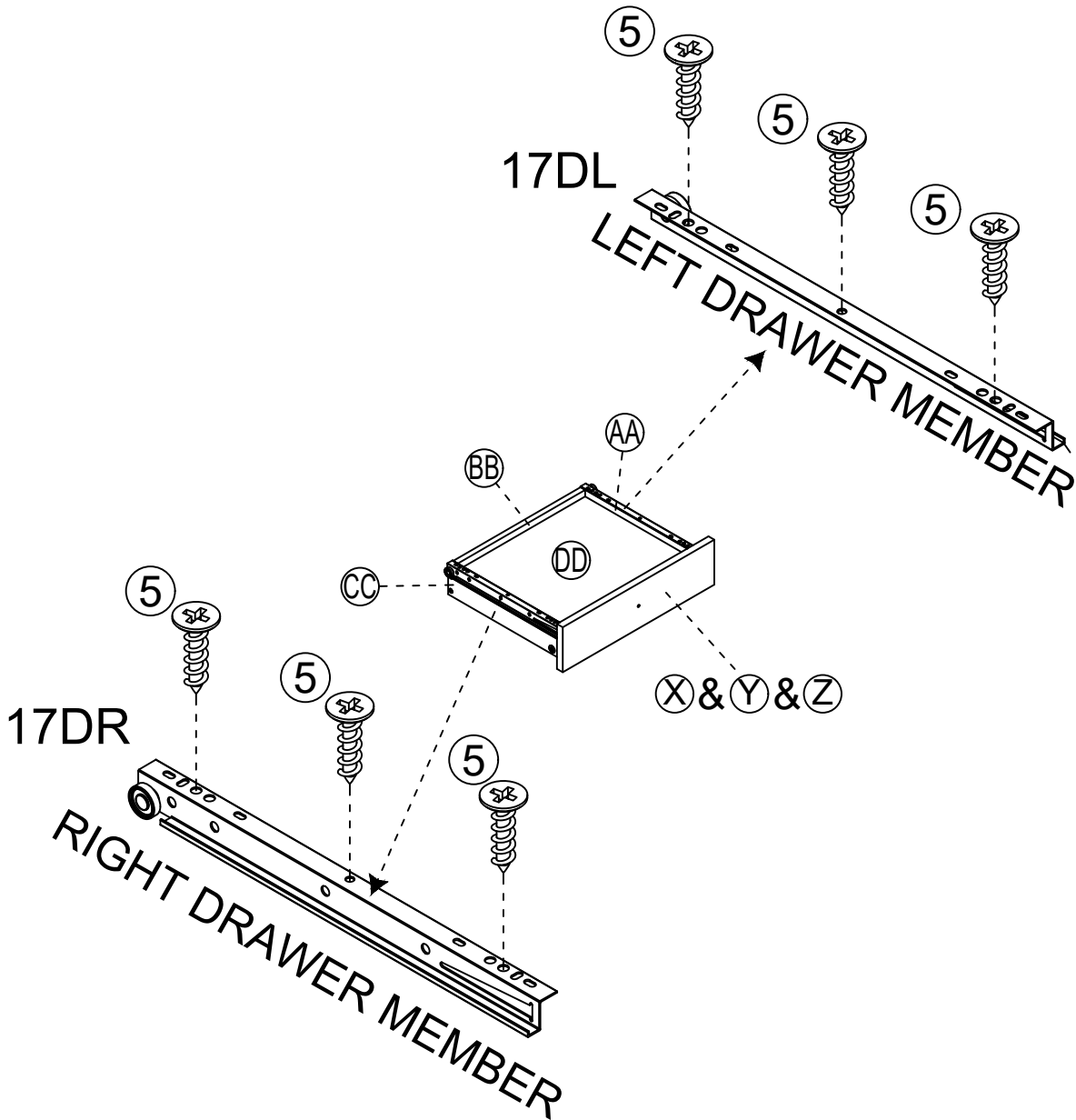

# X3

# STEP5

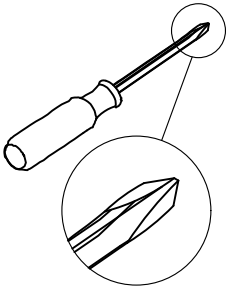

 ø30Xø18X34.5mm	
8	X11

 M4X18mm	
9	X11

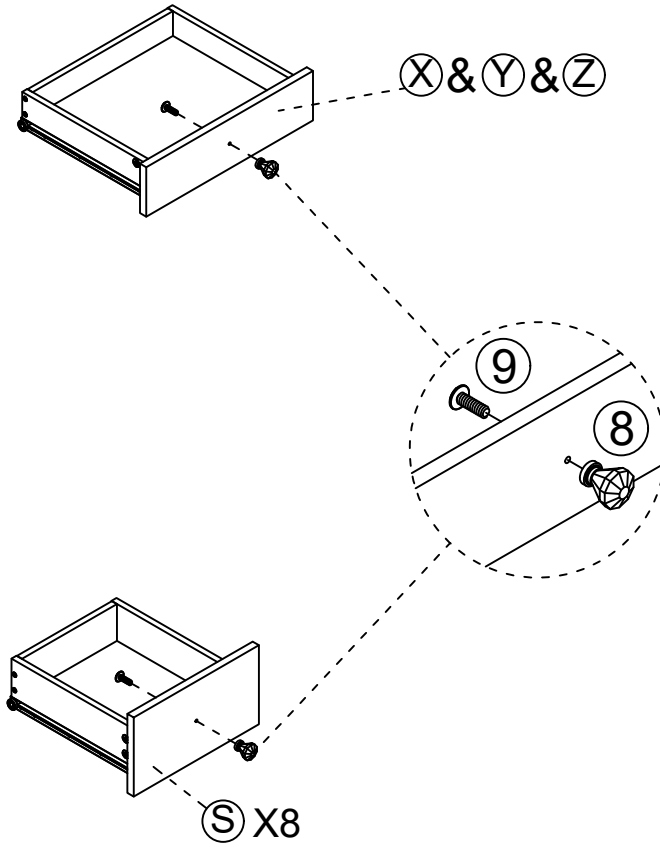

# STEP 6

---

## WARNING

### How To SEPARATE BALL BEARING SLIDE.

- 1) Pull toward arrow to open the slide until its stops and then flip it over.

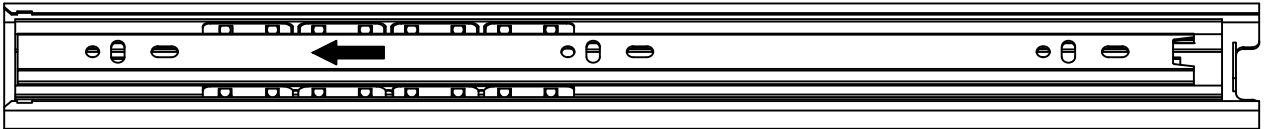

- 2) Push plastic lever down and pull apart.



Cabinet Slide Rail

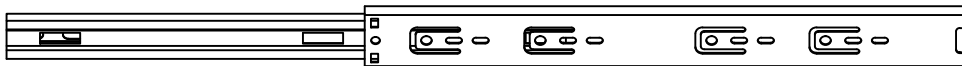

Drawer Slide Rail

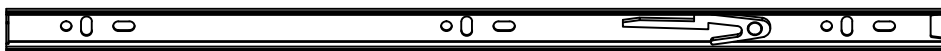



# STEP 8

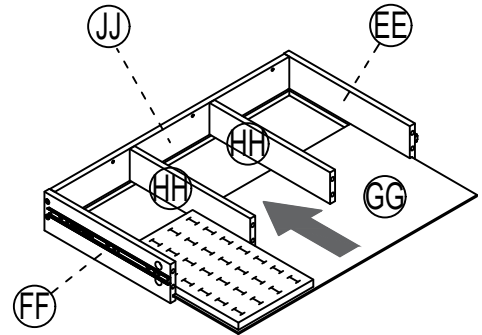
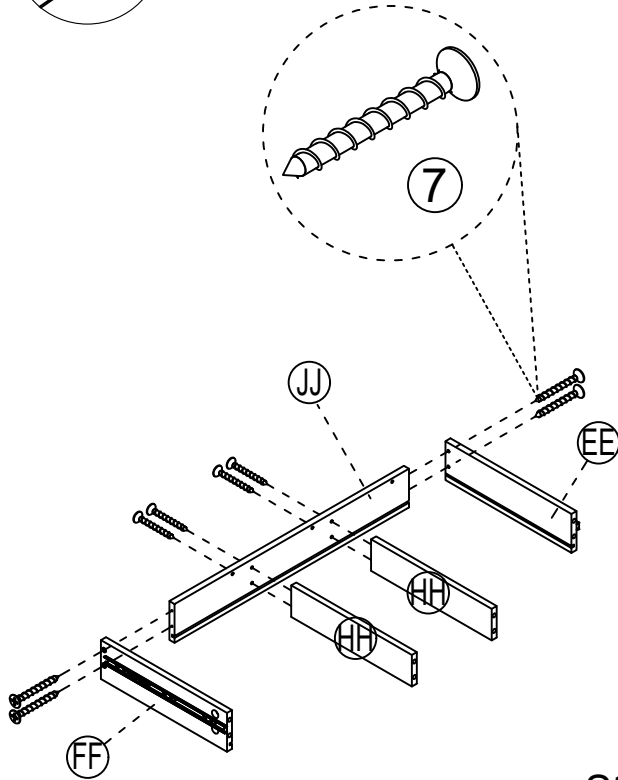
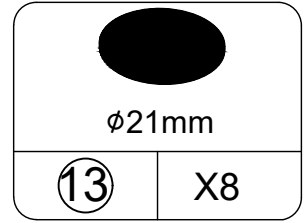
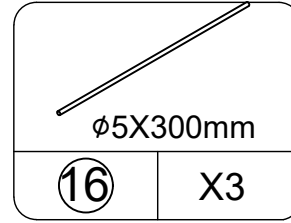
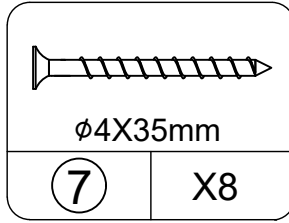
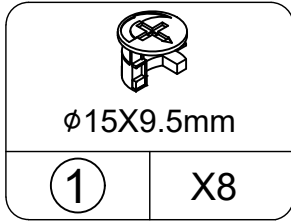
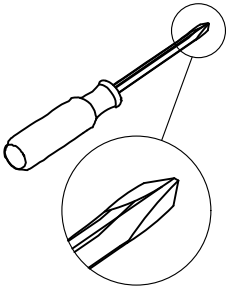

Step 1 Step 2

Step 4 Step 3

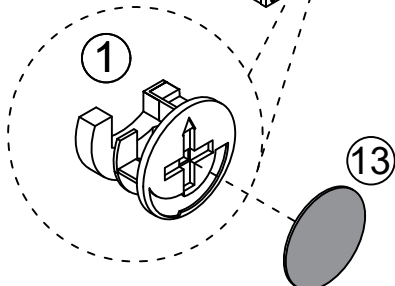
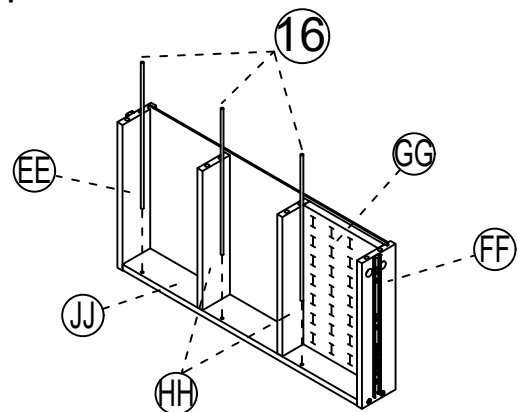
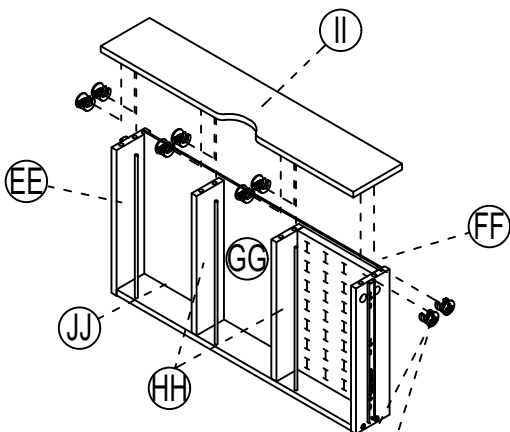

Insert the cam bolt into the hole first, then insert the cam lock and lock it.

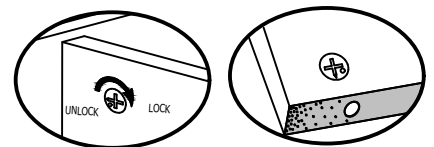

Proper orientation of CAM LOCK

# STEP 9

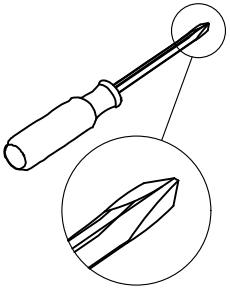

ø15X9.5mm	
1	X8

ø4X35mm	
7	X8

ø5X300mm	
16	X3

ø21mm	
13	X8

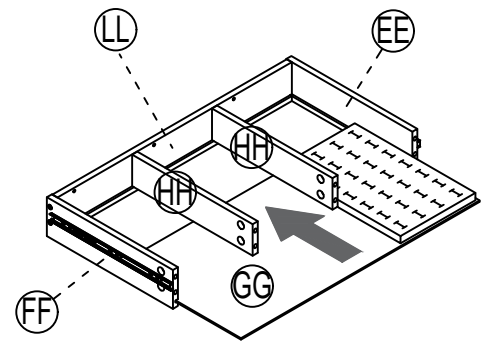
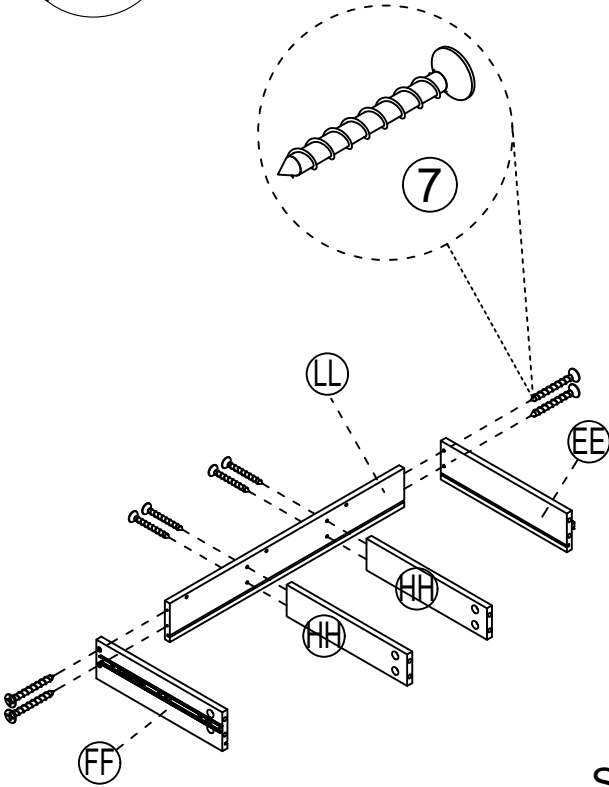

Step 1 Step 2

Step 4 Step 3

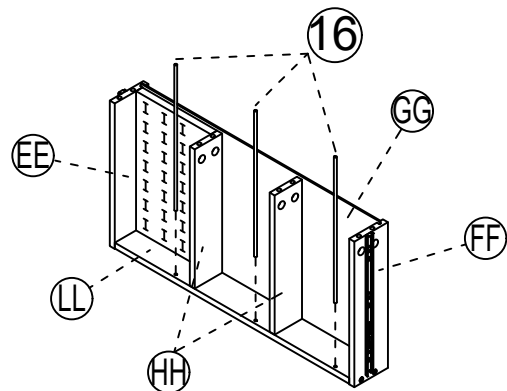
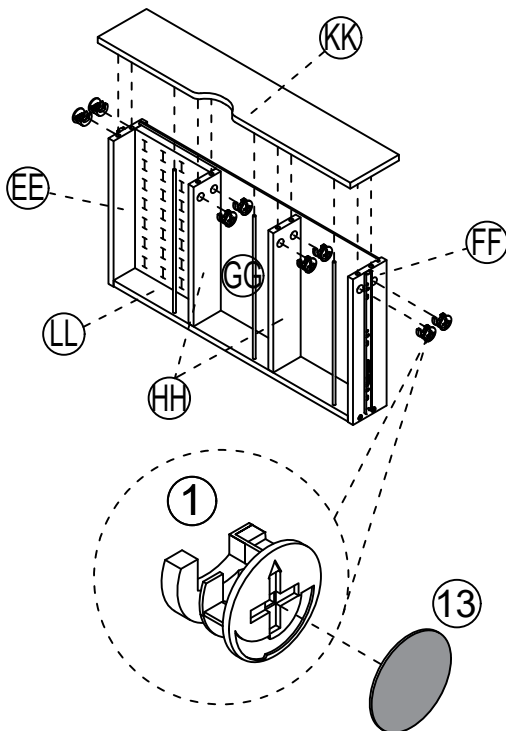

Insert the cam bolt into the hole first, then insert the cam lock and lock it.

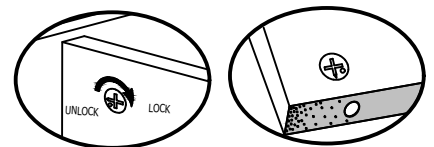

Proper orientation of CAM LOCK

# STEP10

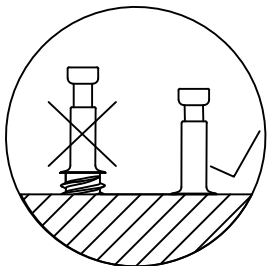
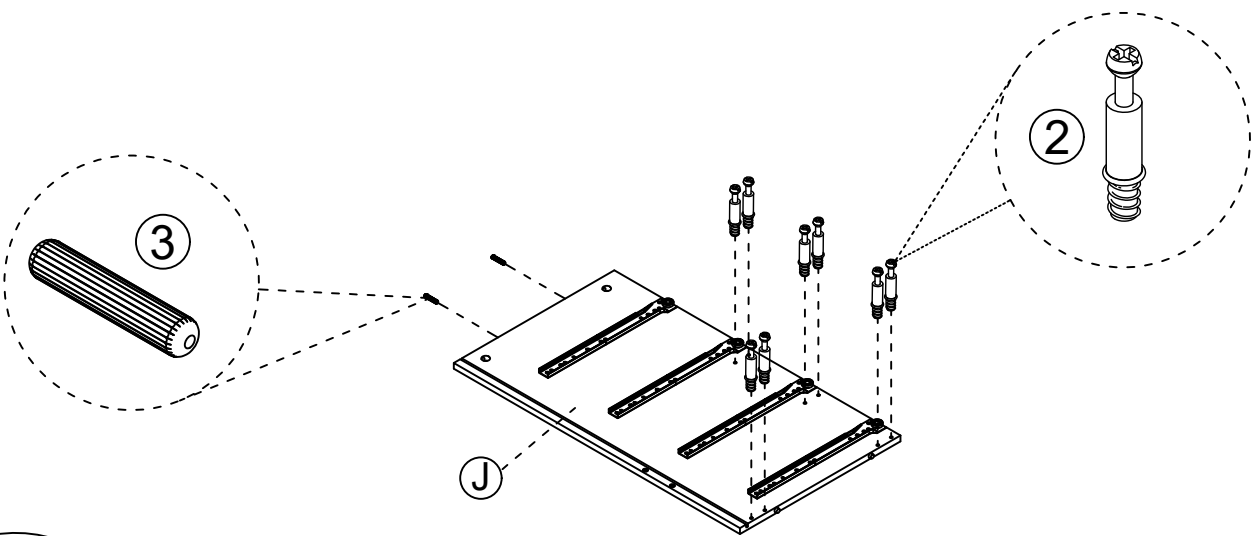
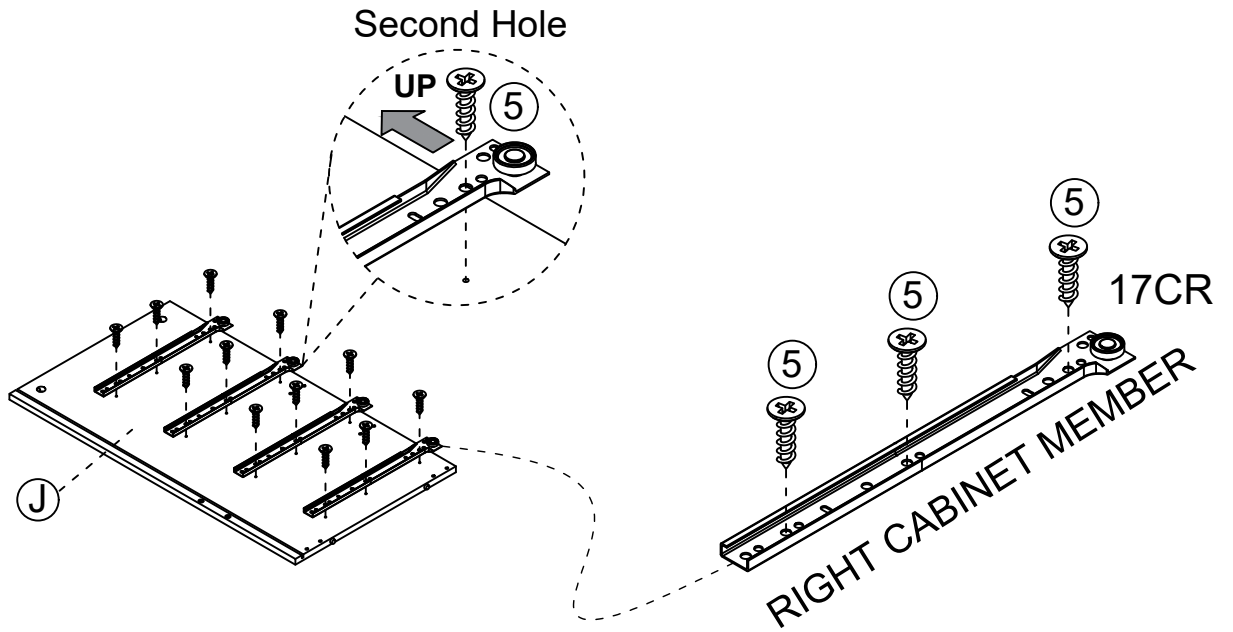
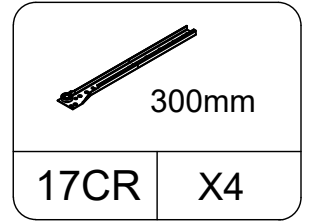
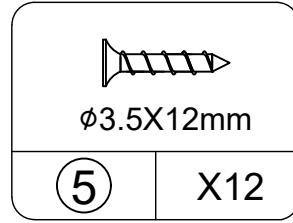
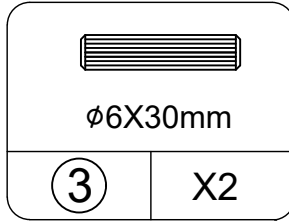
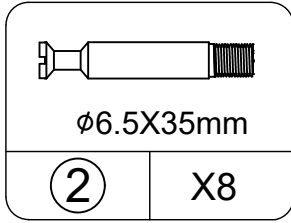
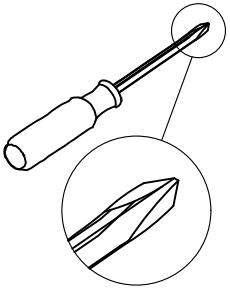

# STEP11

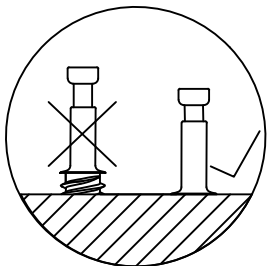
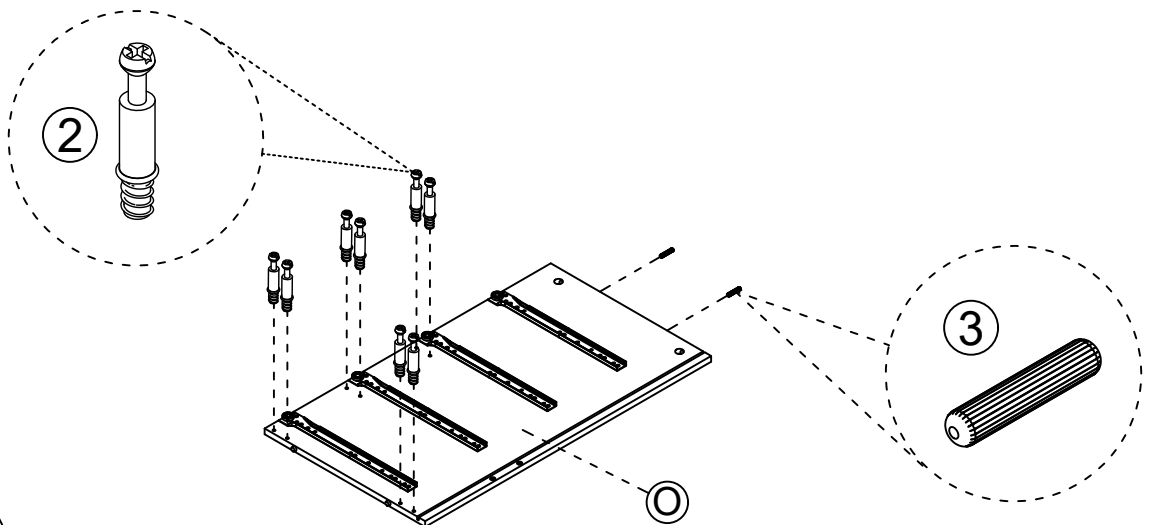
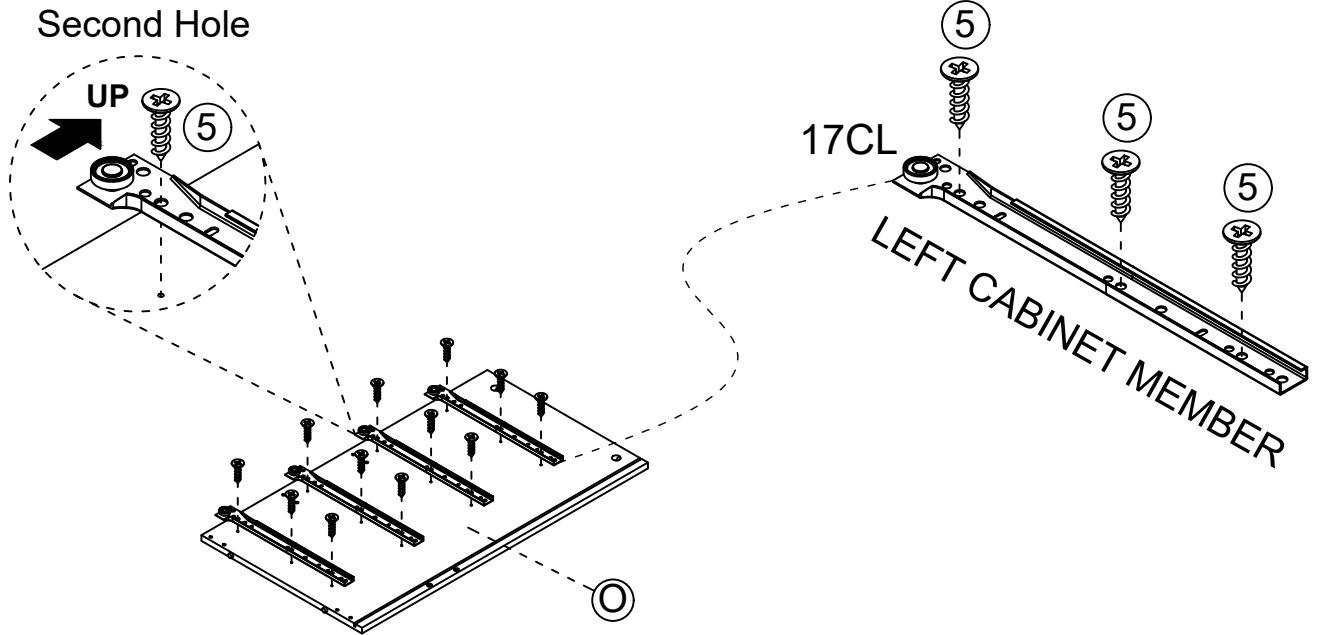
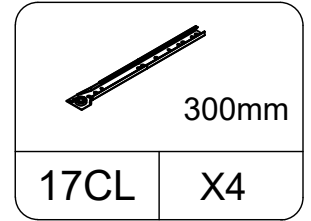
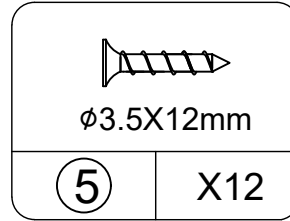
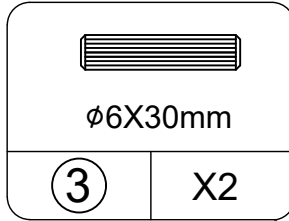
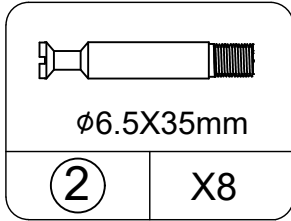
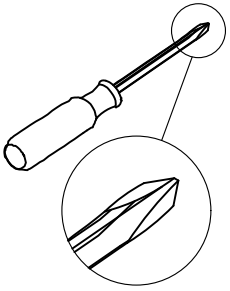

# STEP12

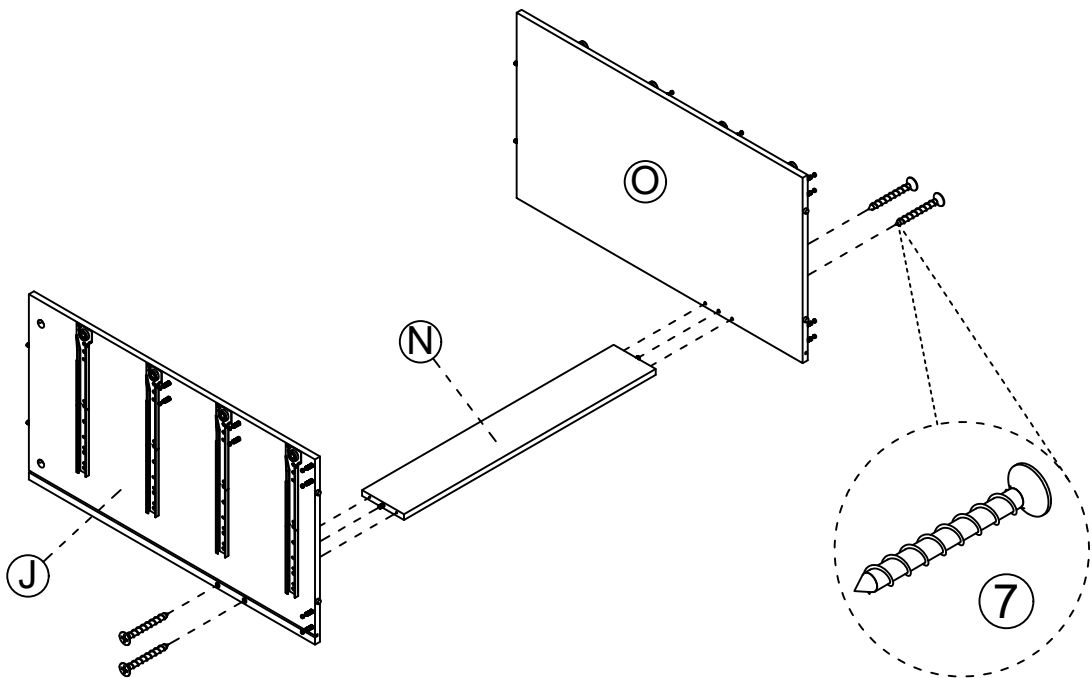
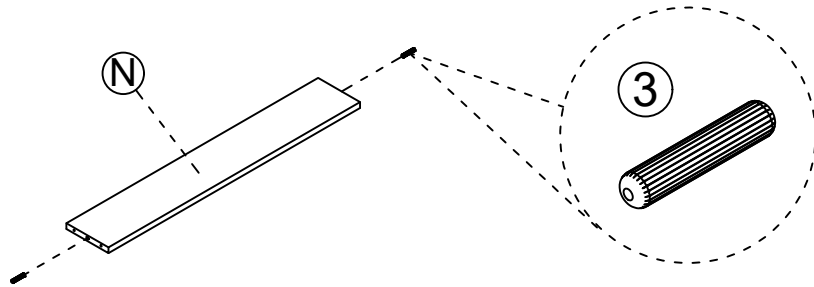
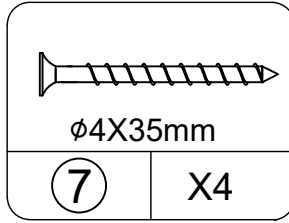
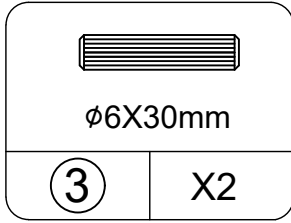
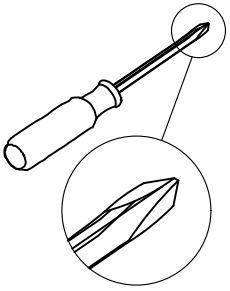

# STEP13

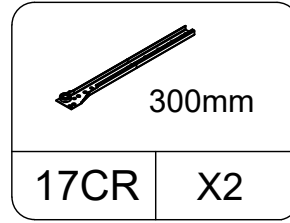
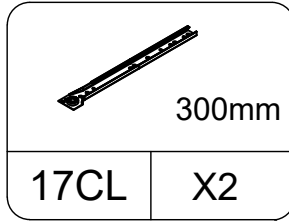
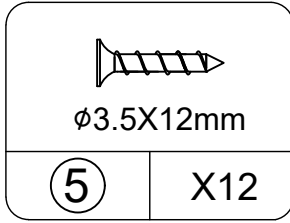
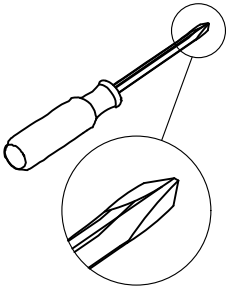

First Hole

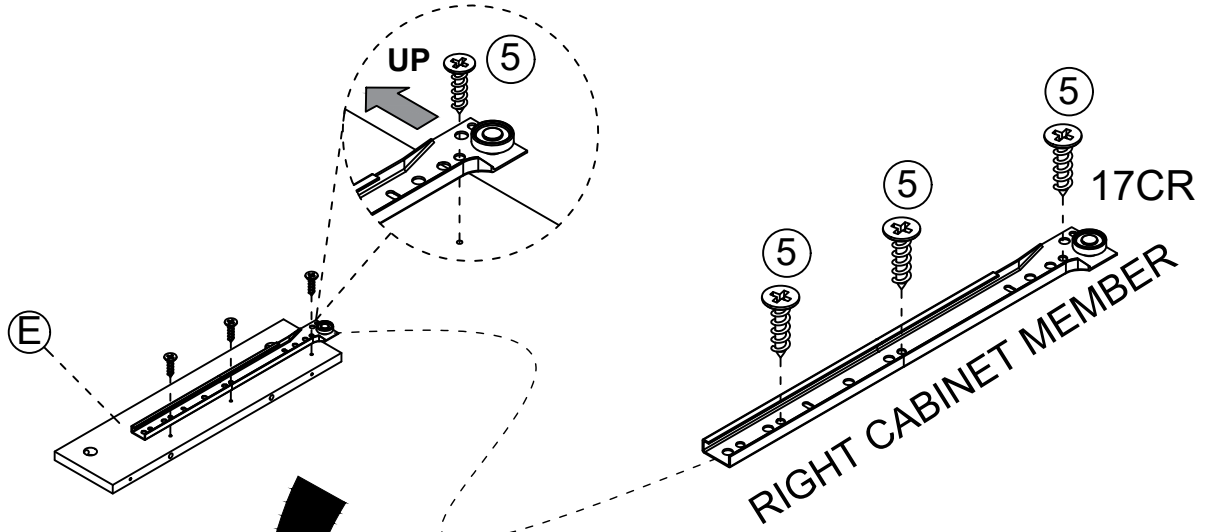

Second Hole

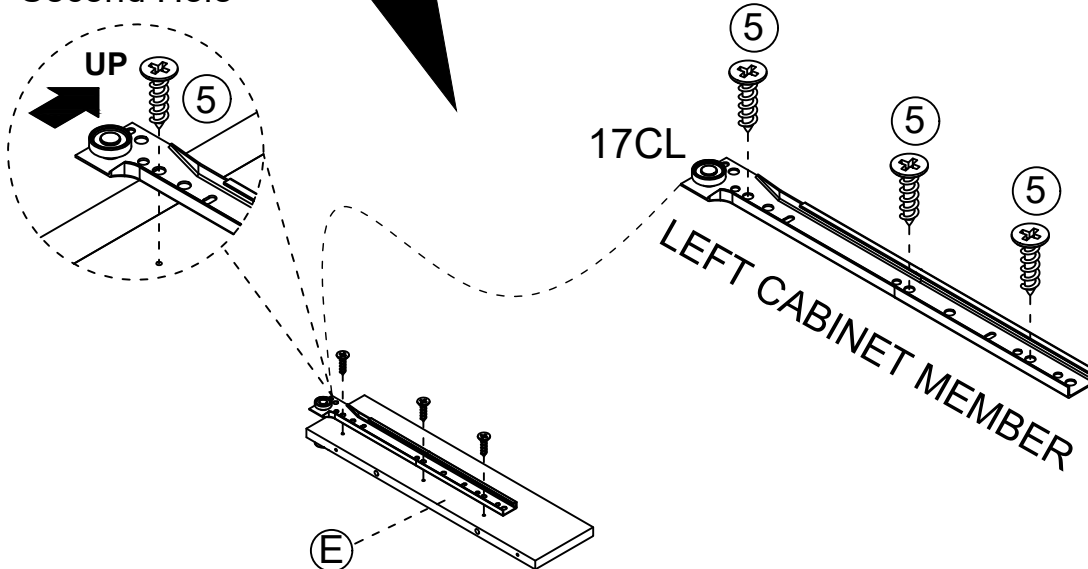

# X2

# STEP14

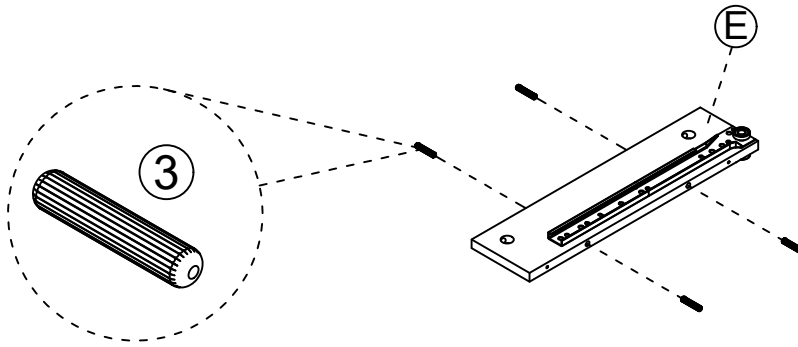
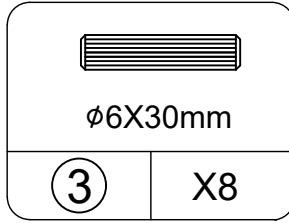
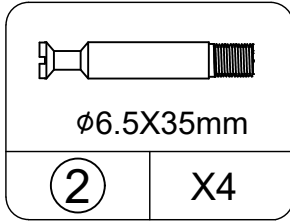
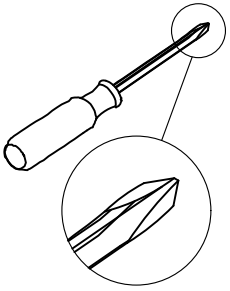

X2

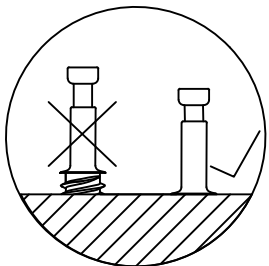
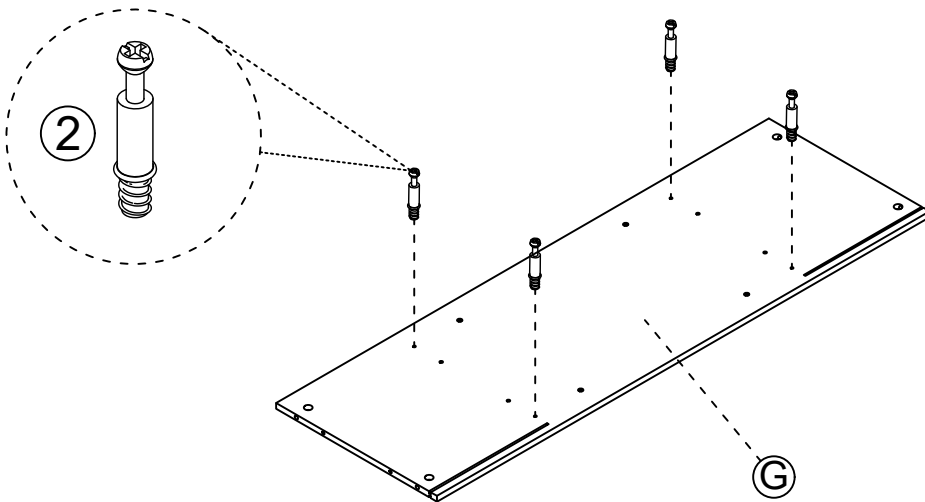

# STEP15

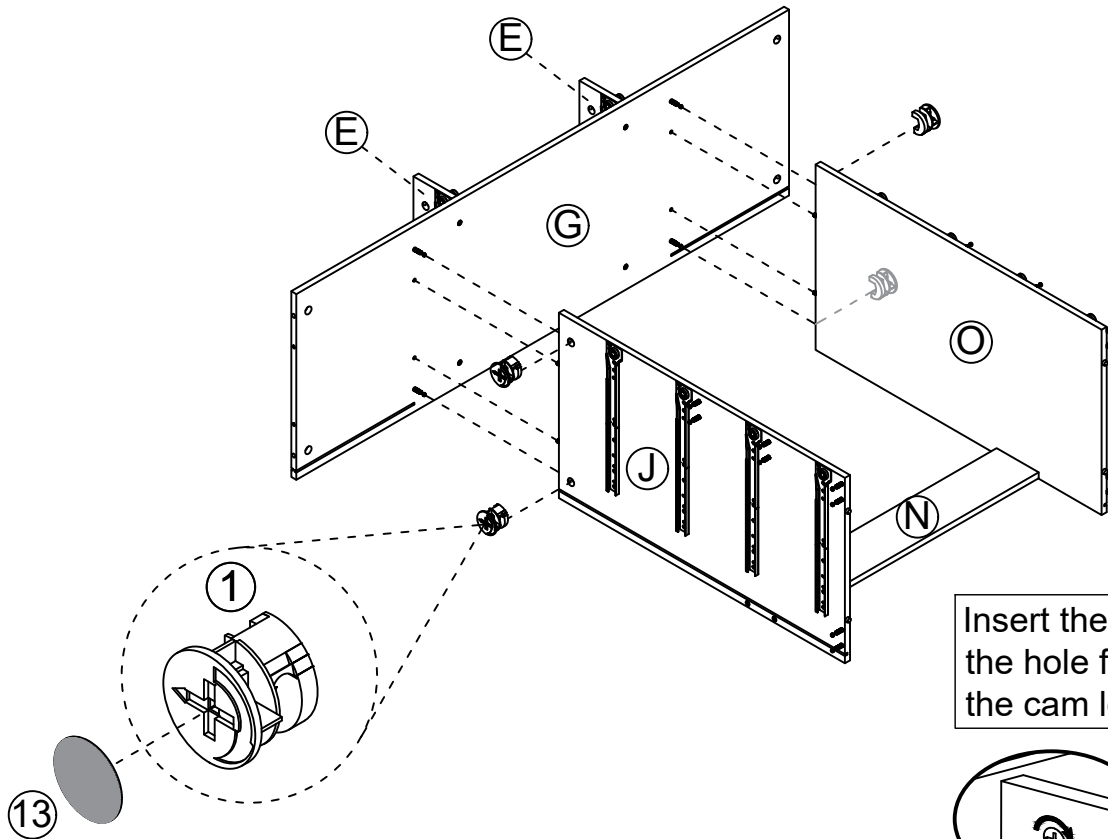
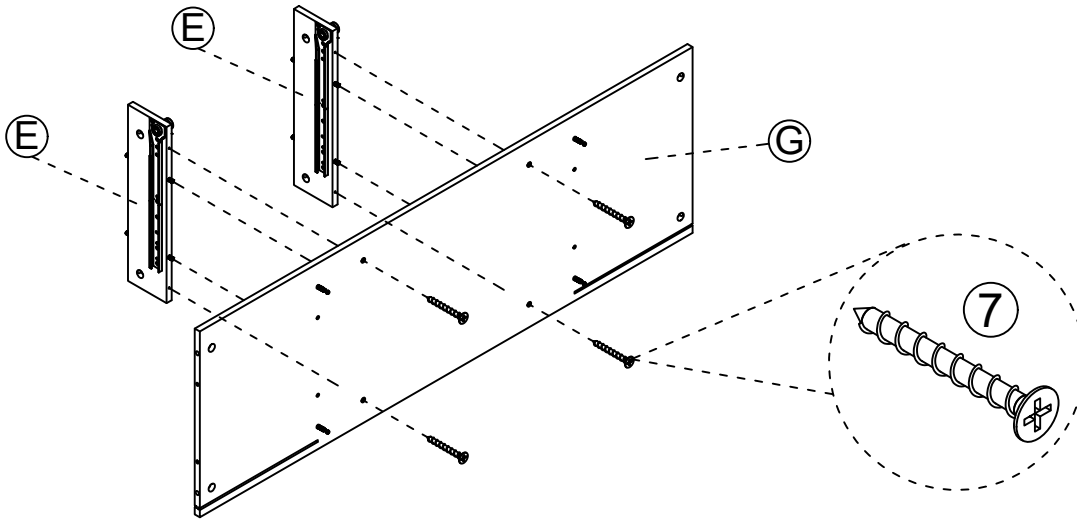
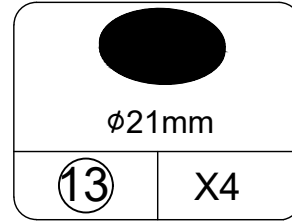
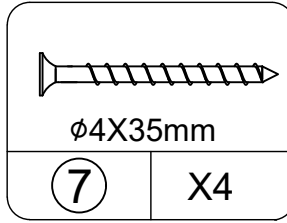
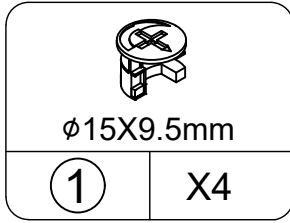
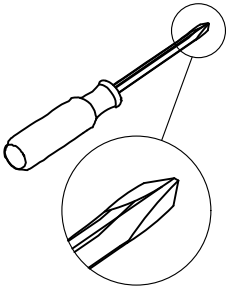

Insert the cam bolt into the hole first, then insert the cam lock and lock it.

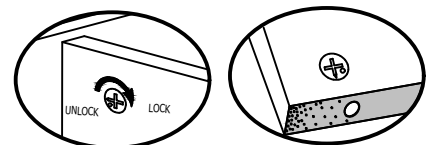

# STEP 16

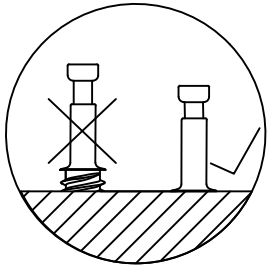
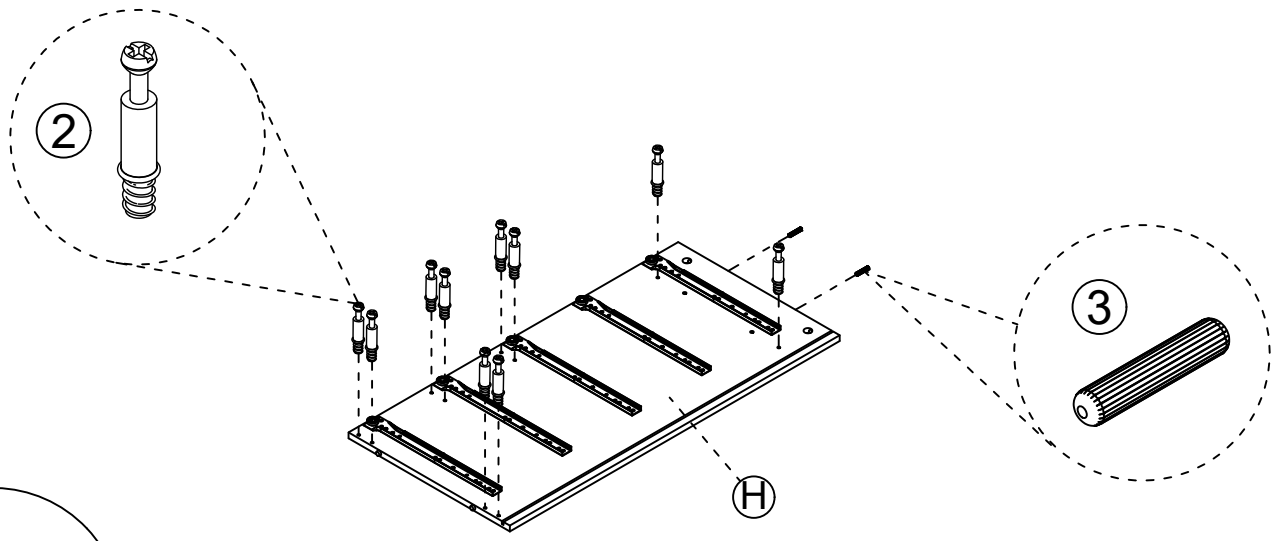
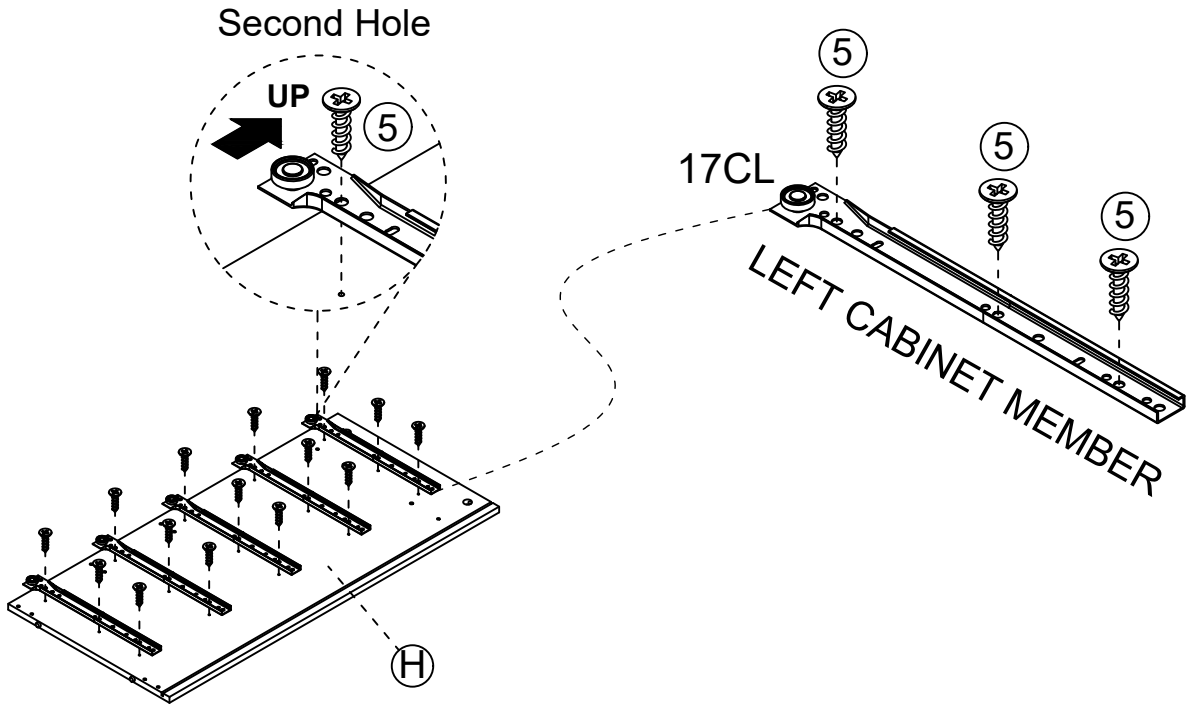
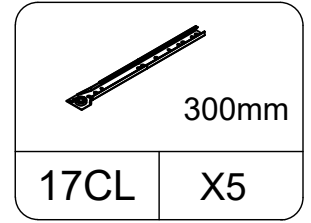
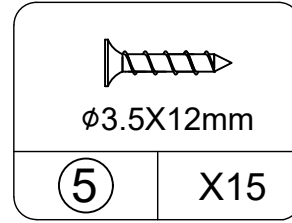
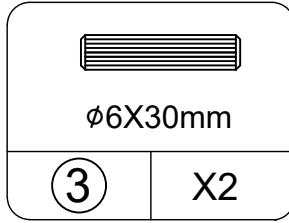
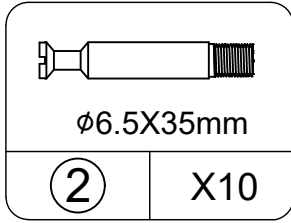
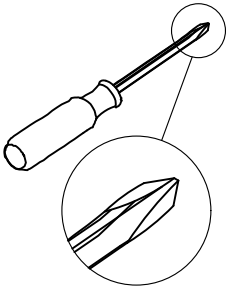

# STEP 17

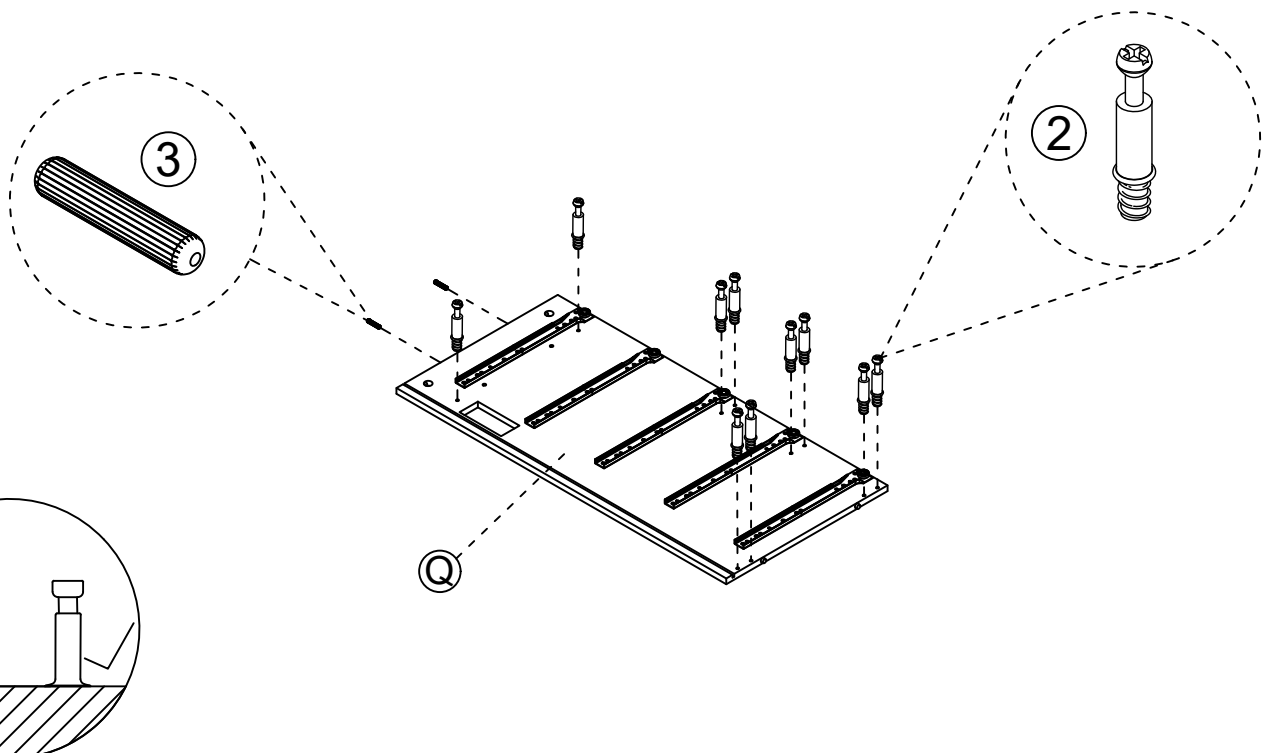
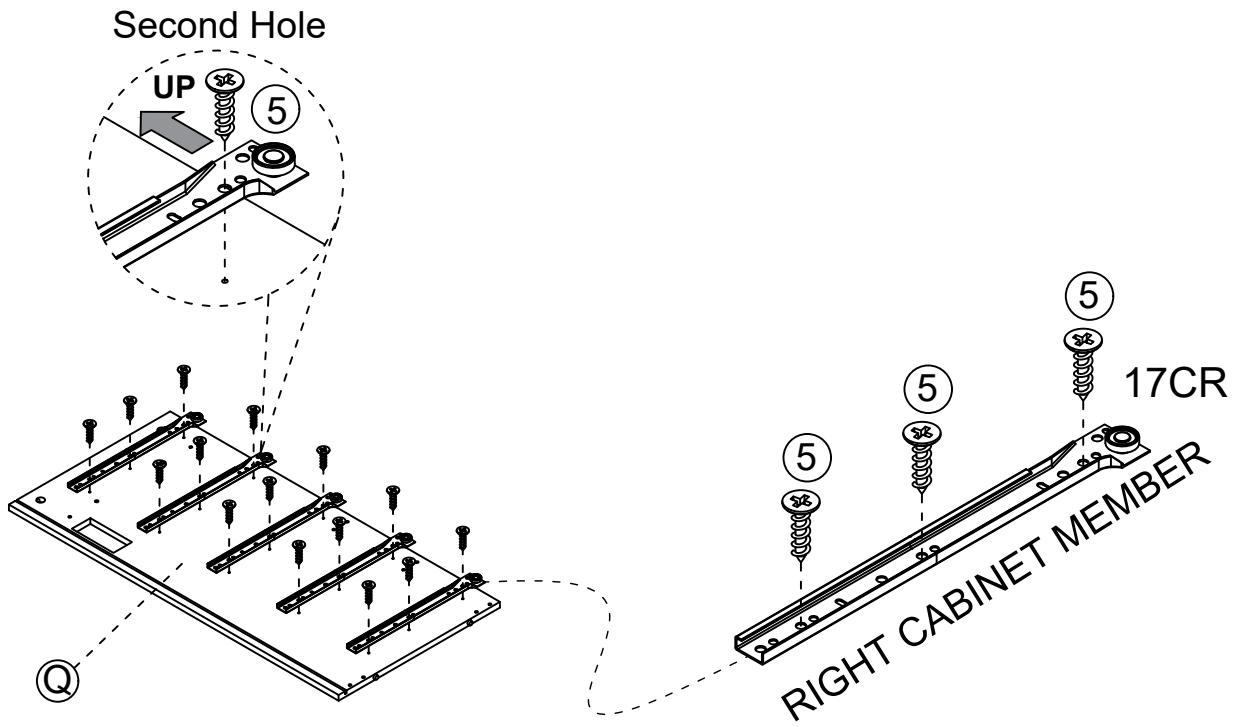
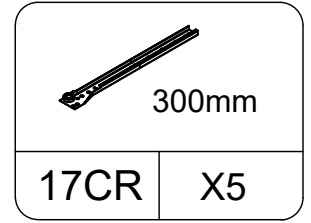
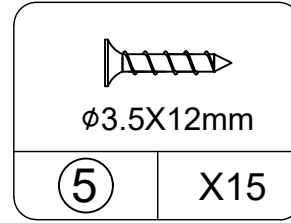
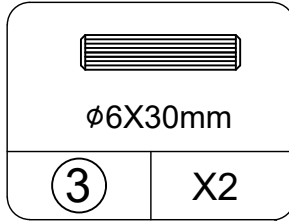
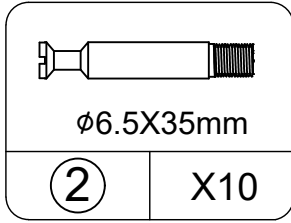
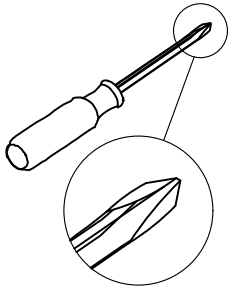

# STEP18

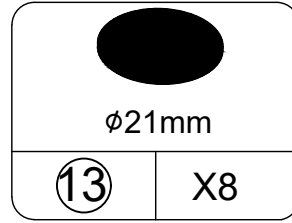
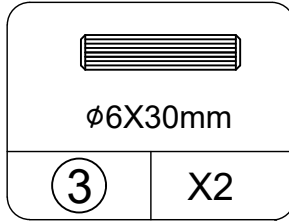
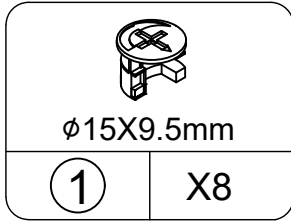
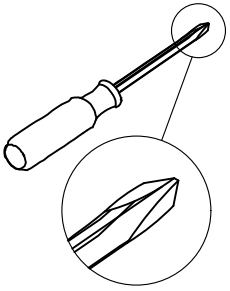

Pay attention to the installation direction

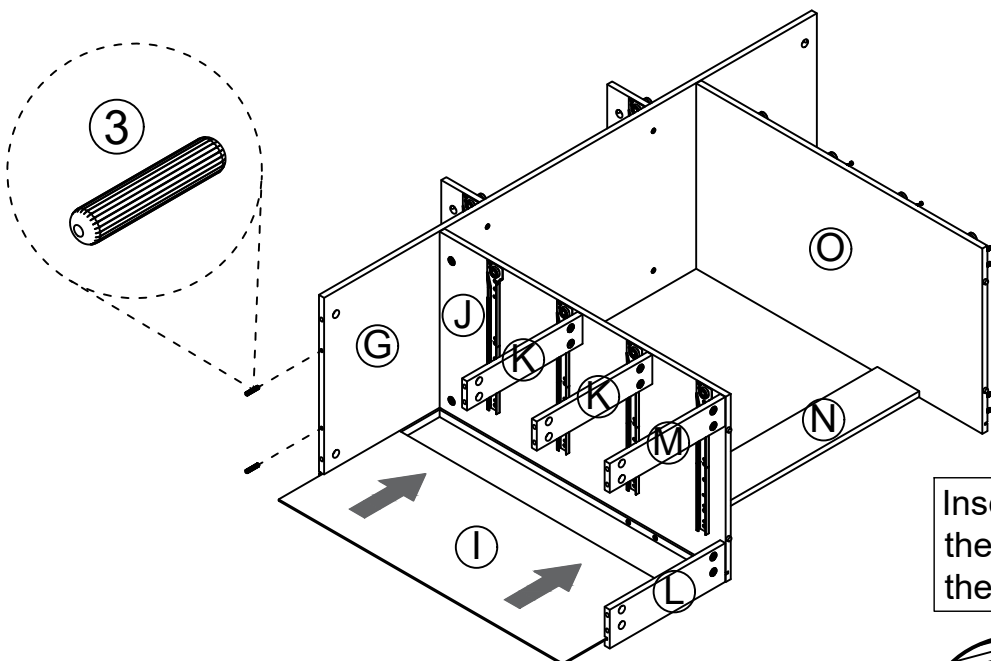
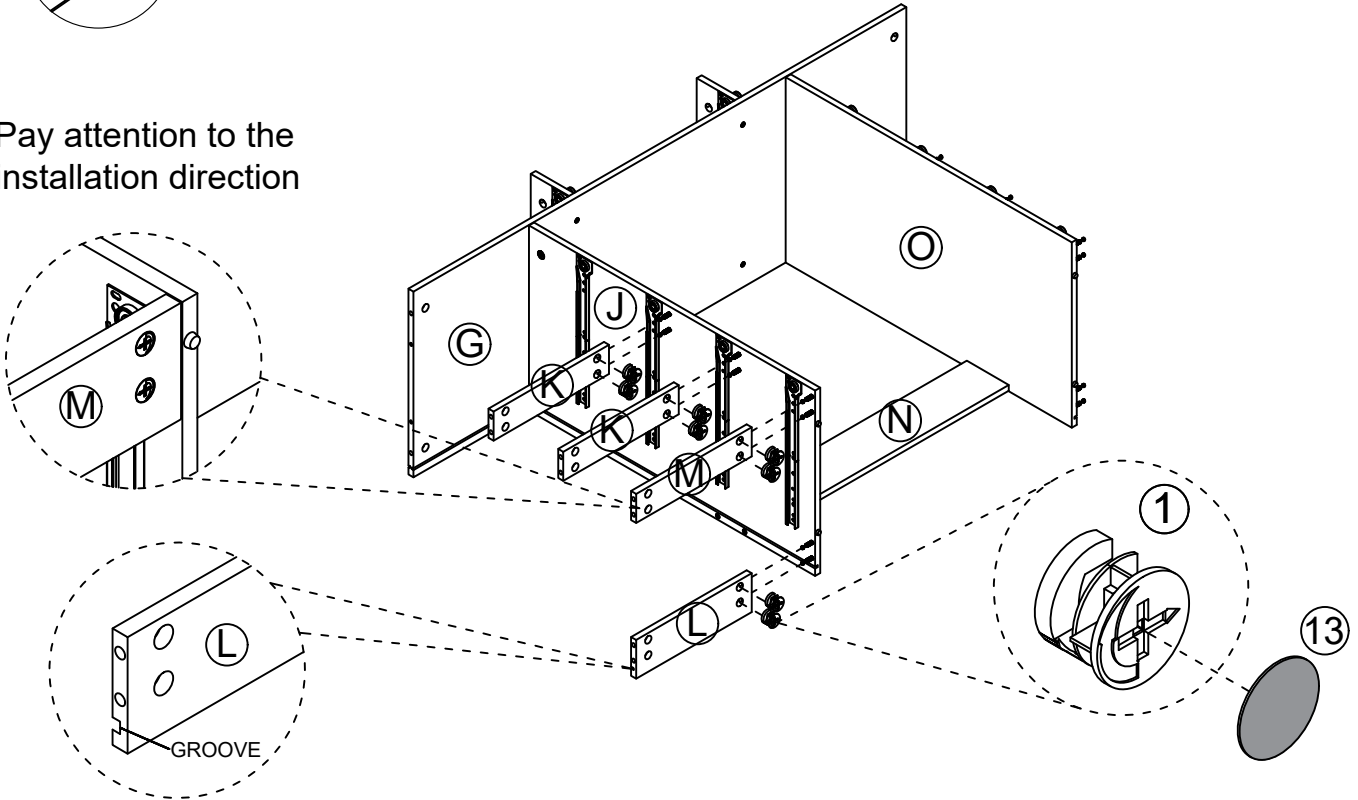

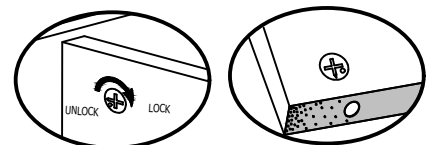

Insert the cam bolt into the hole first, then insert the cam lock and lock it.

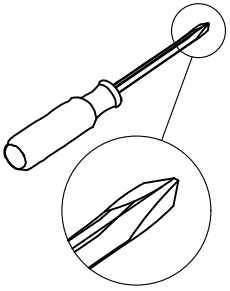

Proper orientation of CAM LOCK

# STEP19



	
ø15X9.5mm	
1	X18

	
ø21mm	
13	X18

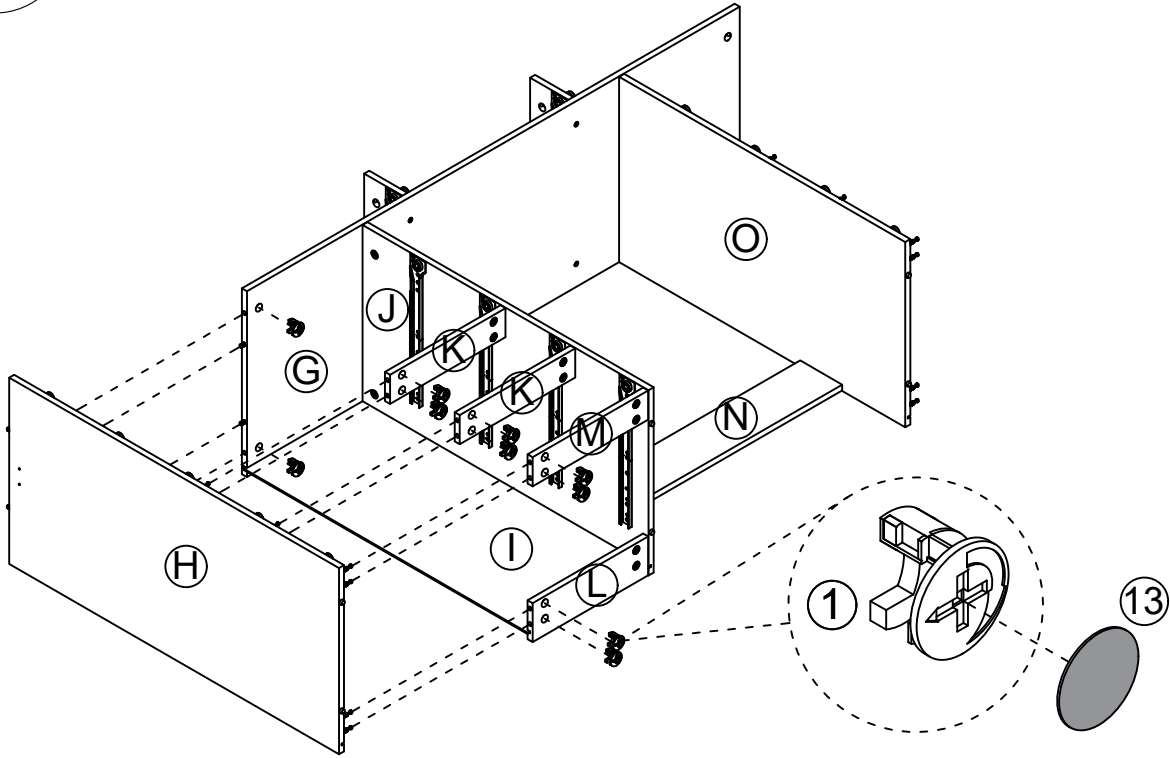

Pay attention to the installation direction

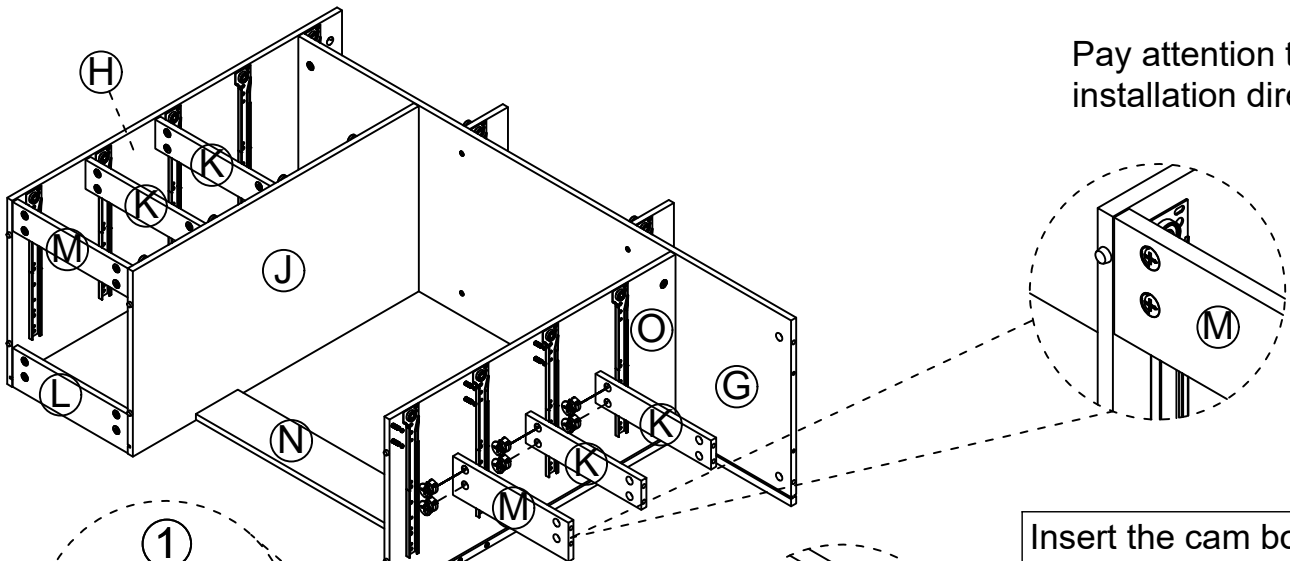

Insert the cam bolt into the hole first, then insert the cam lock and lock it.

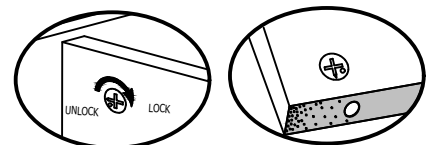

Proper orientation of CAM LOCK

# STEP20

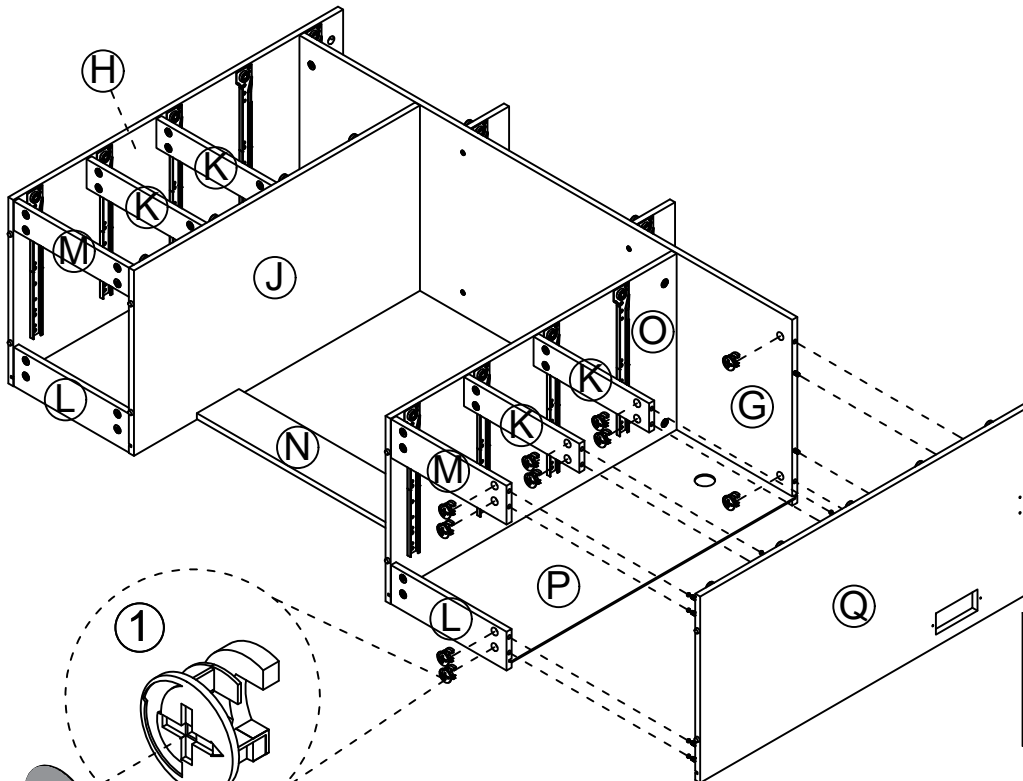
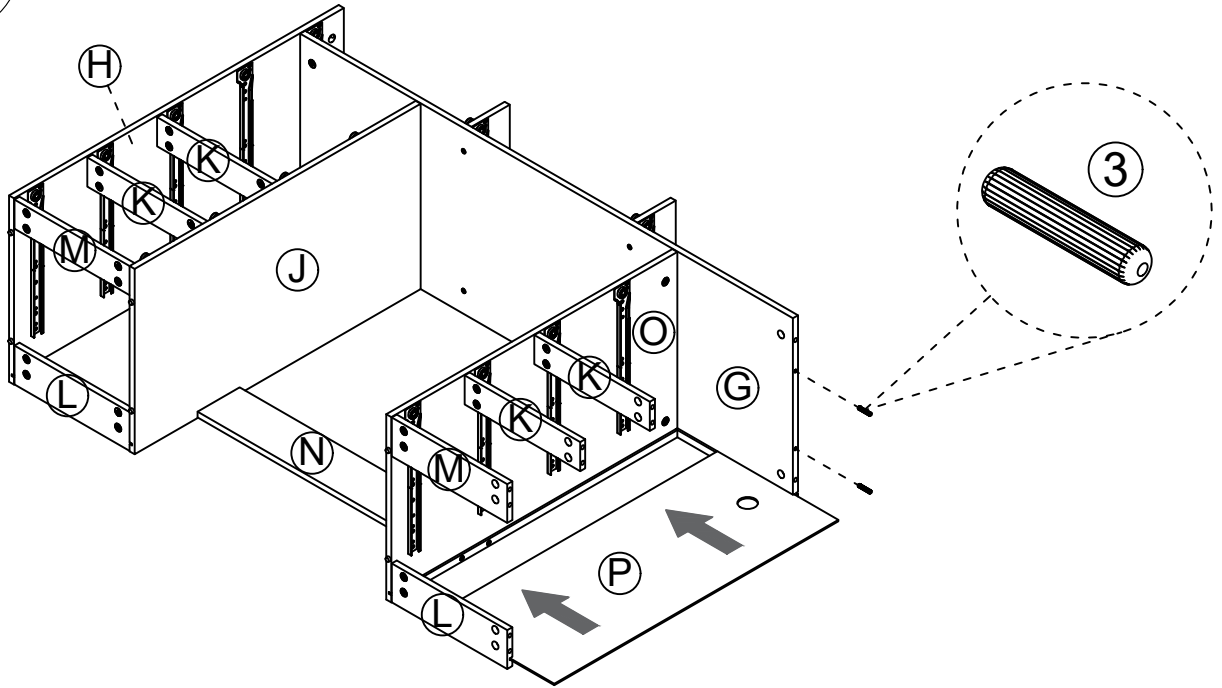
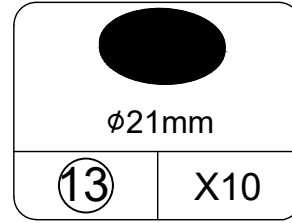
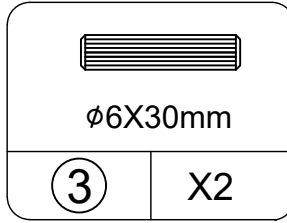
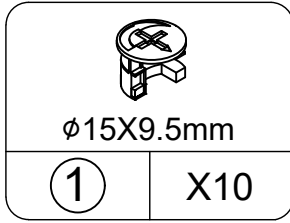
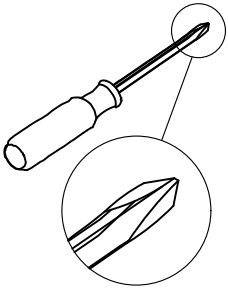

Insert the cam bolt into the hole first, then insert the cam lock and lock it.

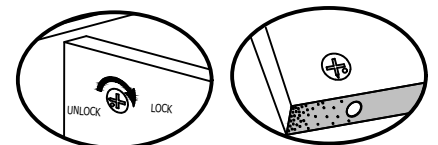
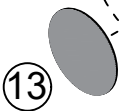

# STEP21

---

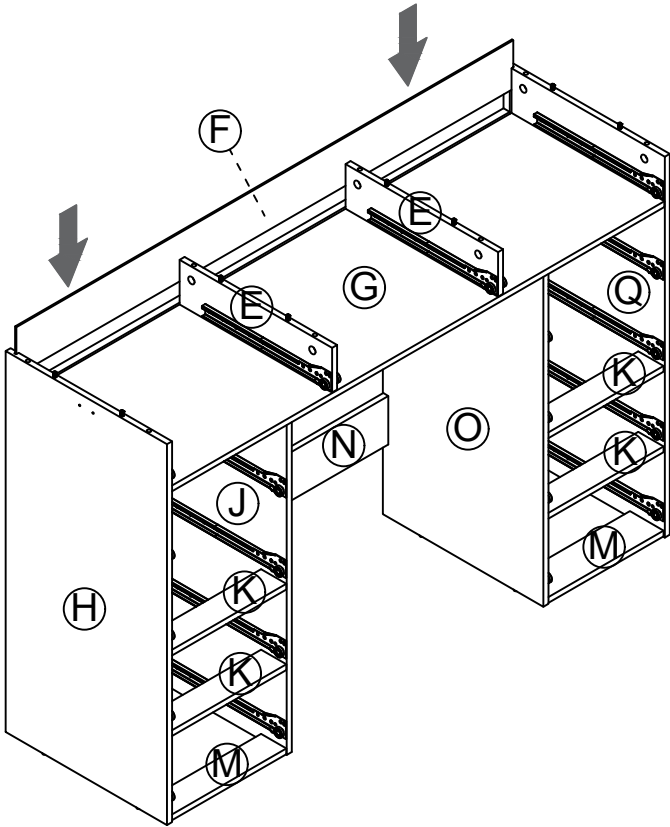

# STEP22

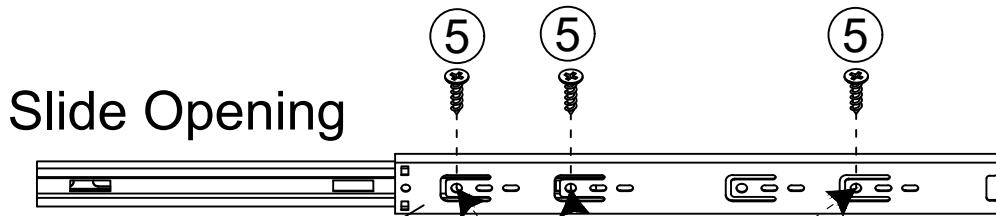
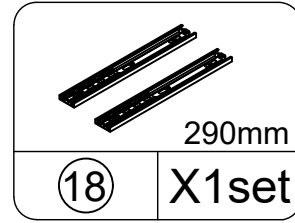
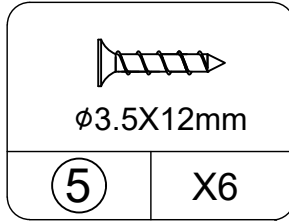
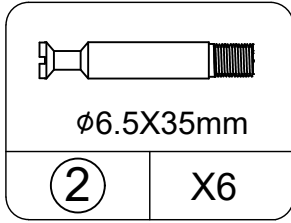
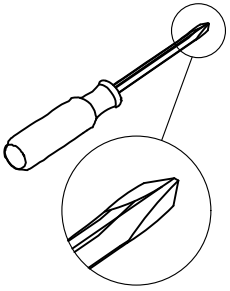

18

Flip the part 18 over, before use the screw 5 when assembling the part 18 to the plate B.

Mounting Holes

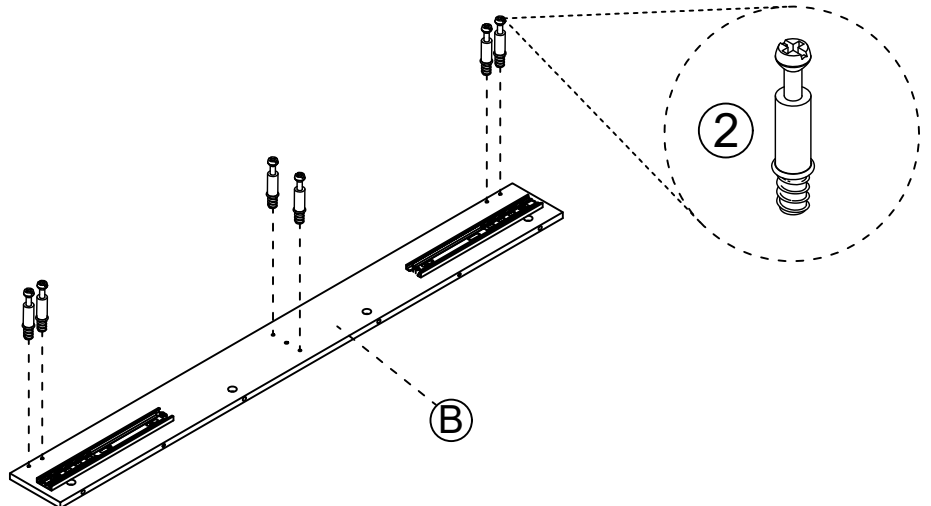
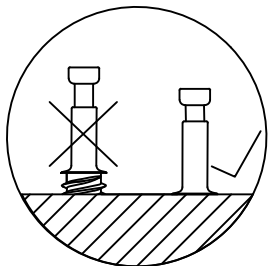
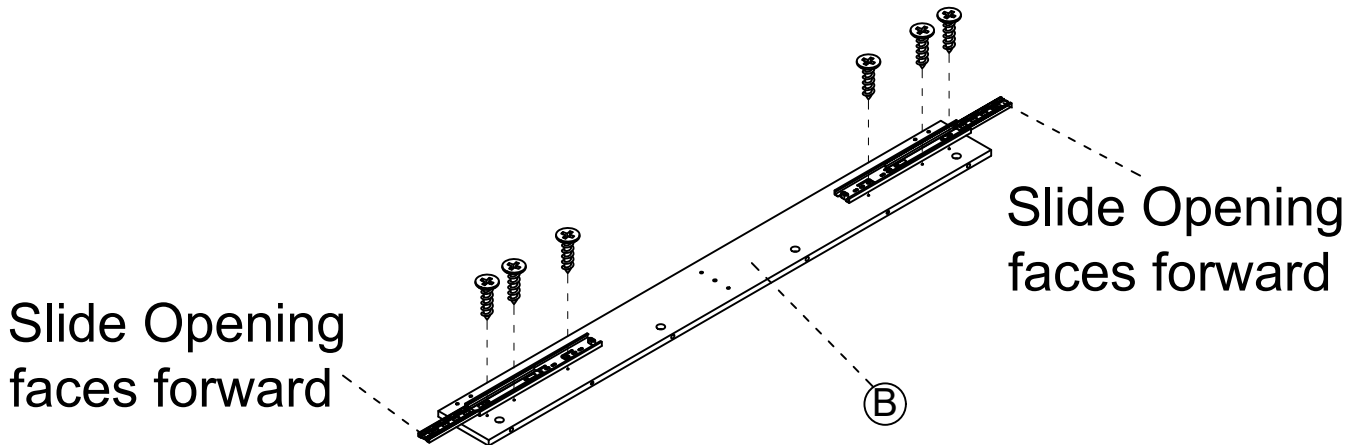

# STEP23

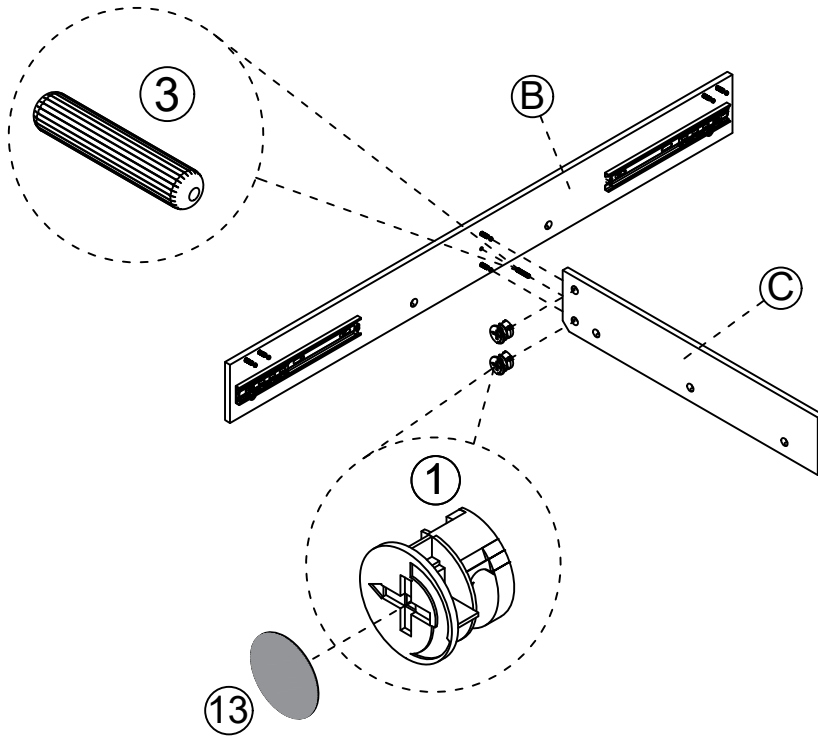
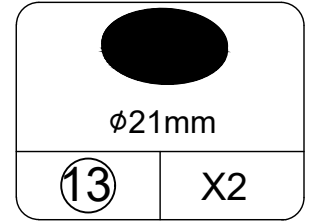
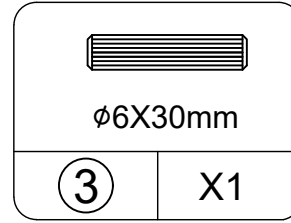
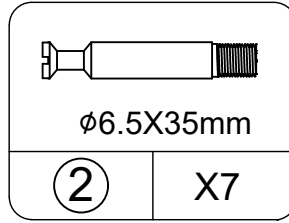
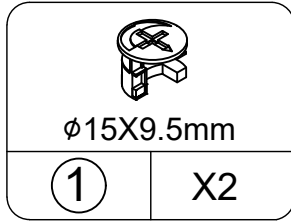
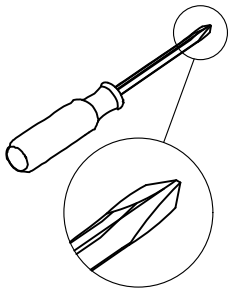

To avoid scratching the mirror surface, please place the board A on the foam before installation.

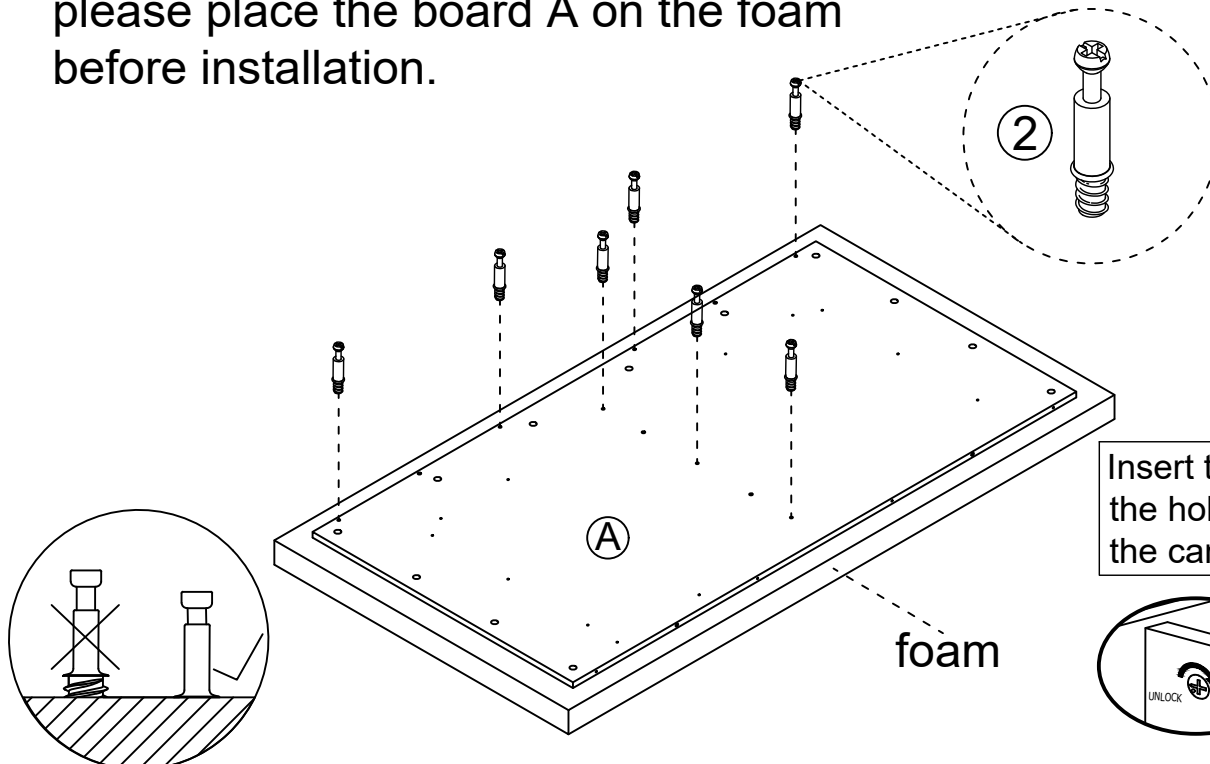

Insert the cam bolt into the hole first, then insert the cam lock and lock it.

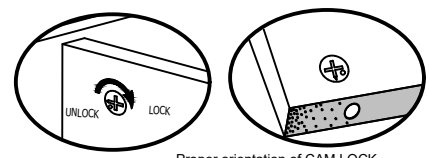

# STEP24

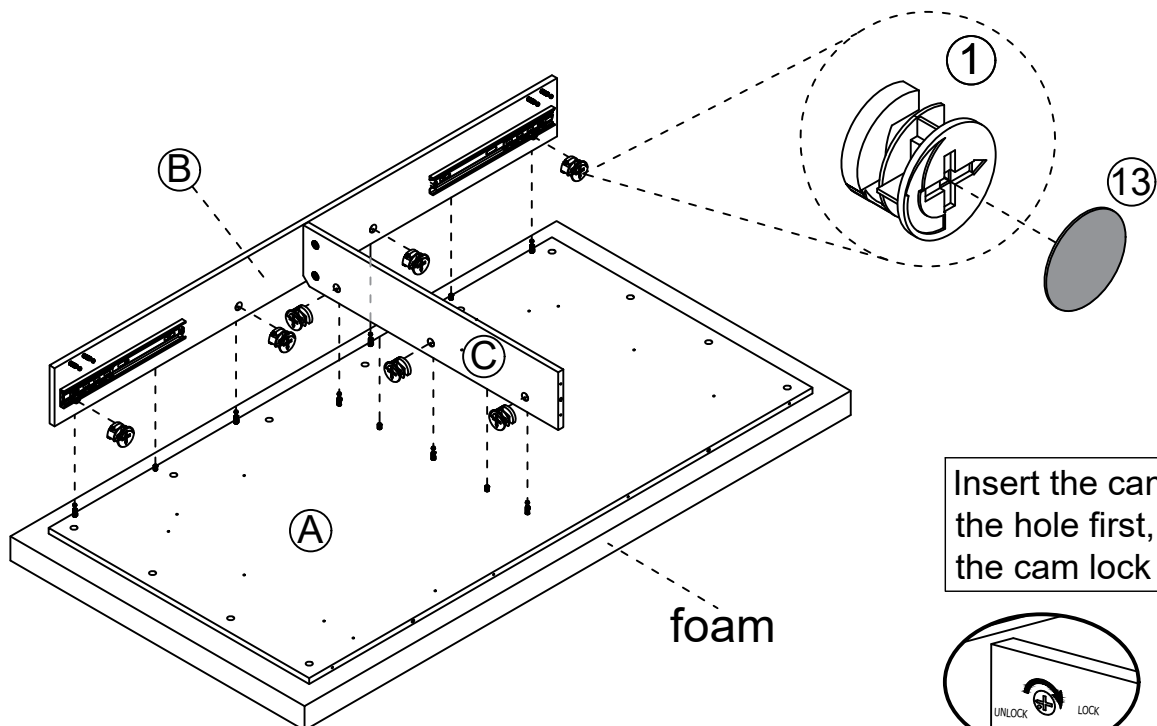
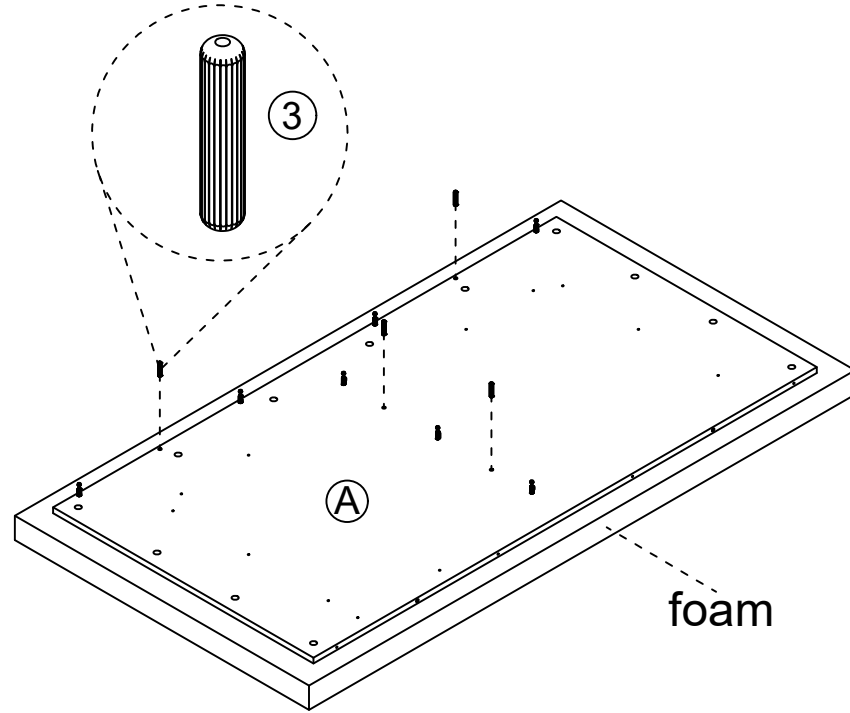
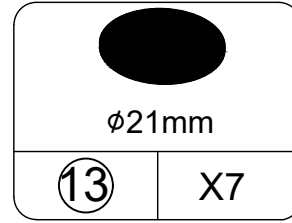
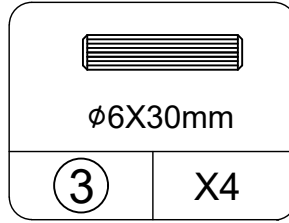
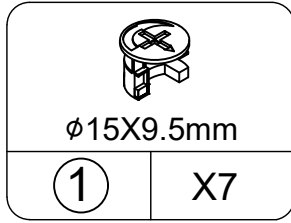
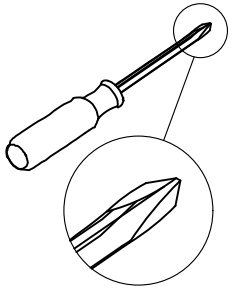

Insert the cam bolt into the hole first, then insert the cam lock and lock it.

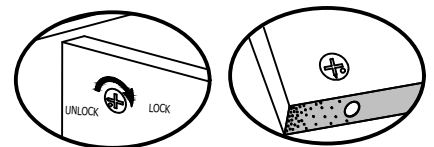

# STEP25

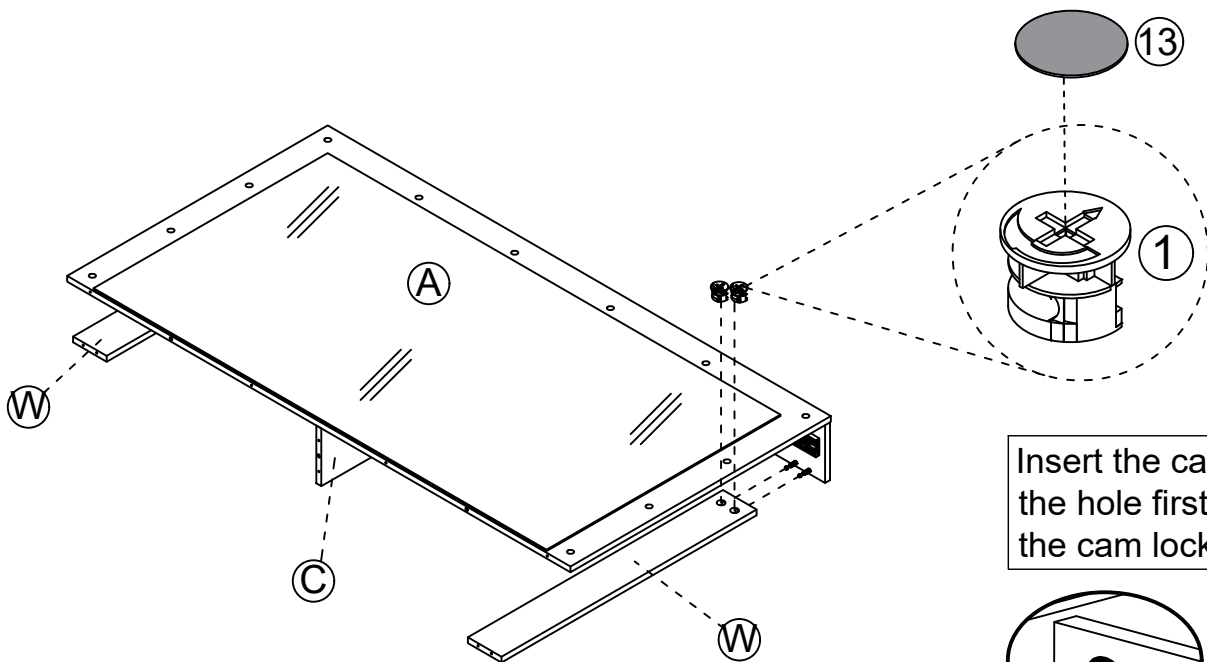
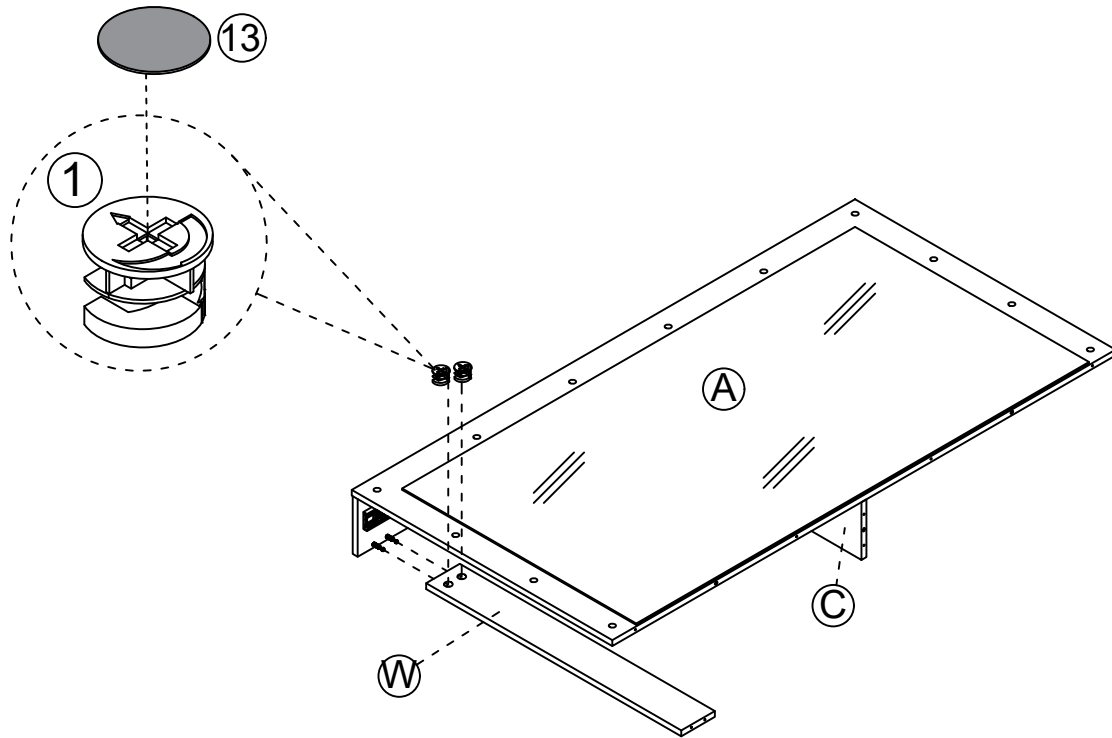
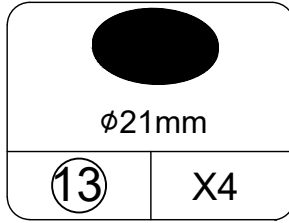
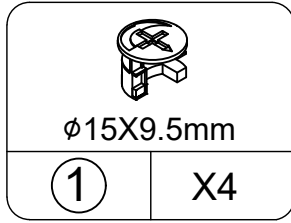
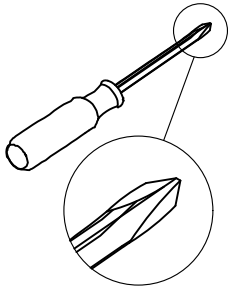

Insert the cam bolt into the hole first, then insert the cam lock and lock it.

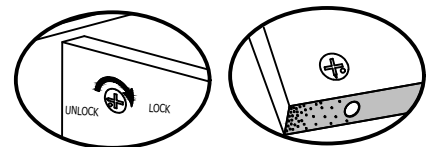

Proper orientation of CAM LOCK

# STEP26

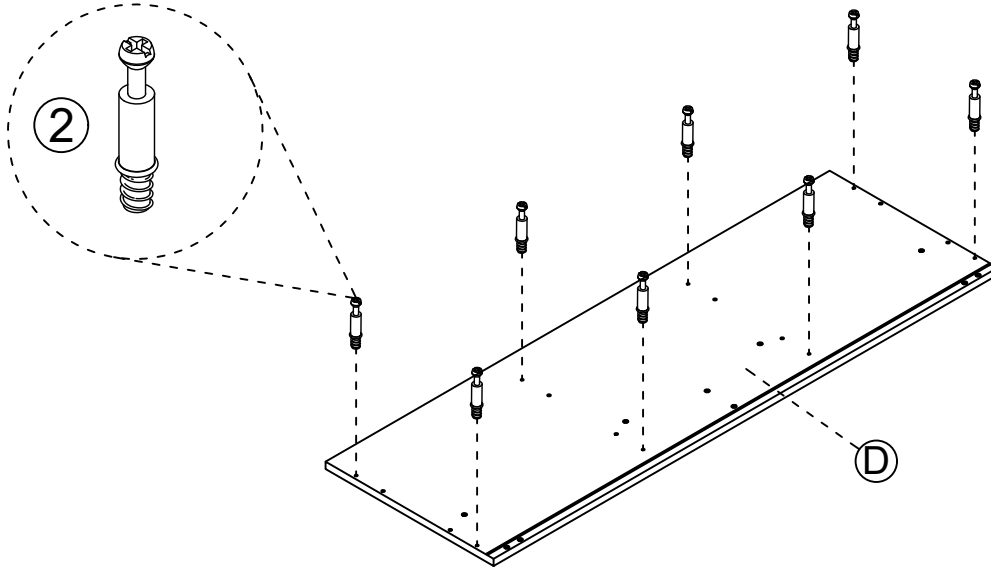
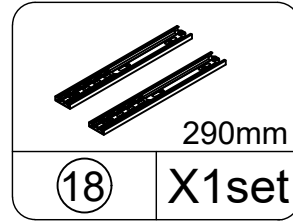
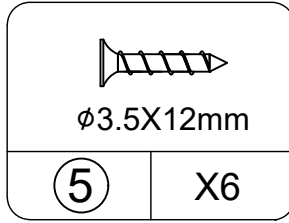
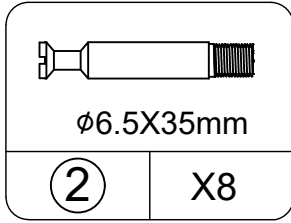
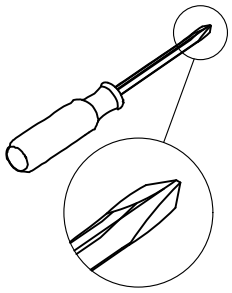

Slide Opening

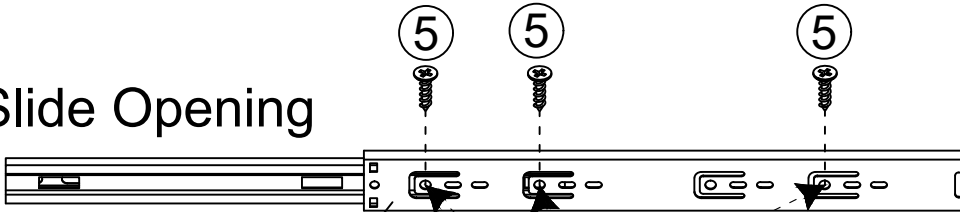

Flip the part 18 over, before use the screw 5 when assembling the part 18 to the plate B.

18

Mounting Holes

Slide Opening faces forward

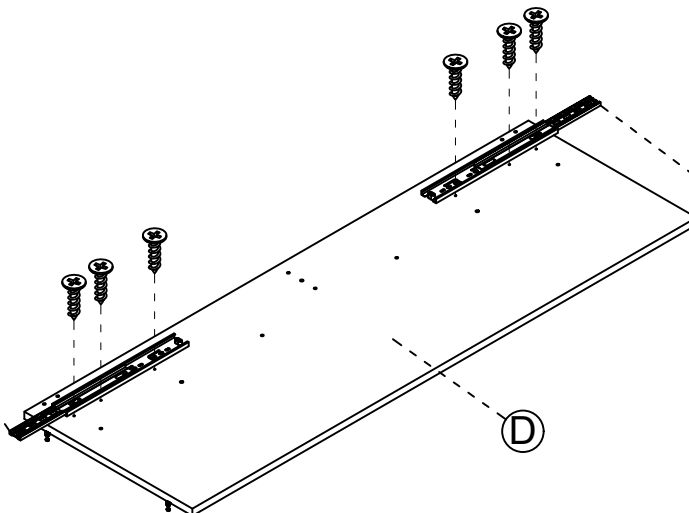
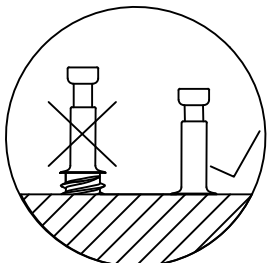

Slide Opening faces forward

# STEP 27

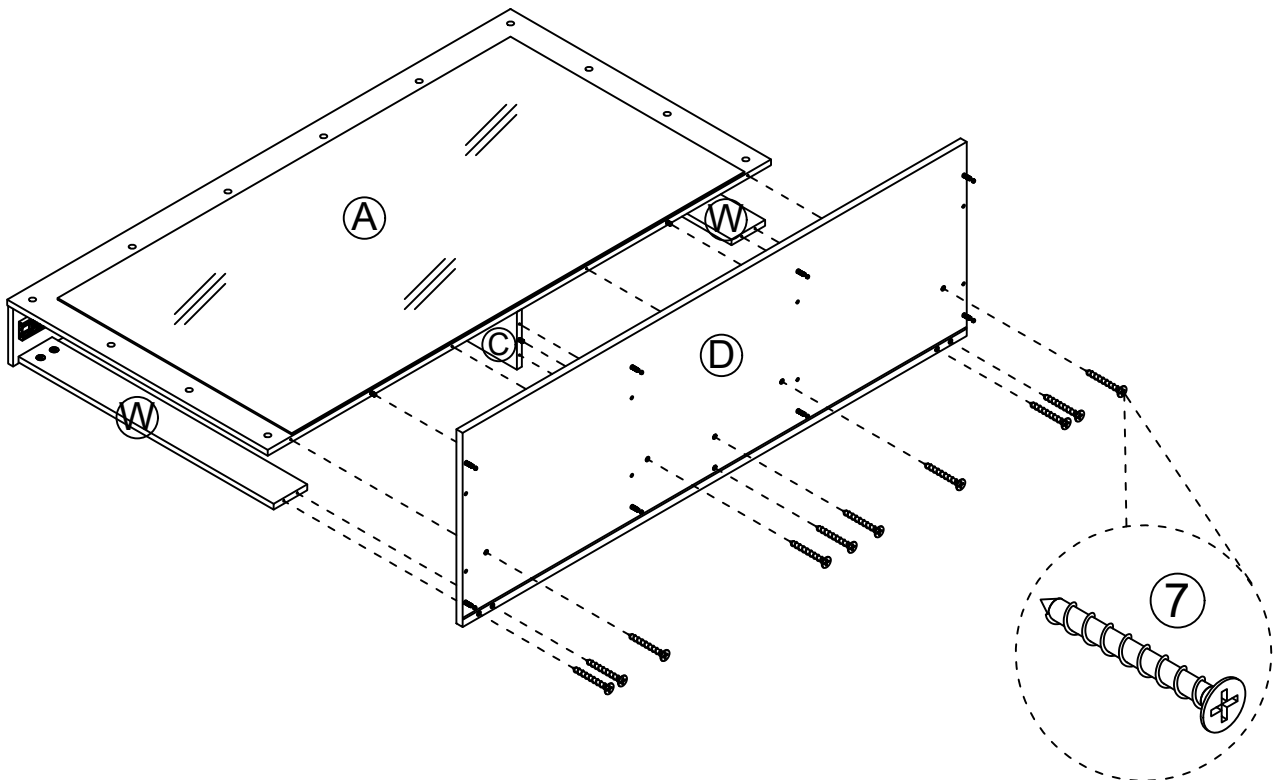
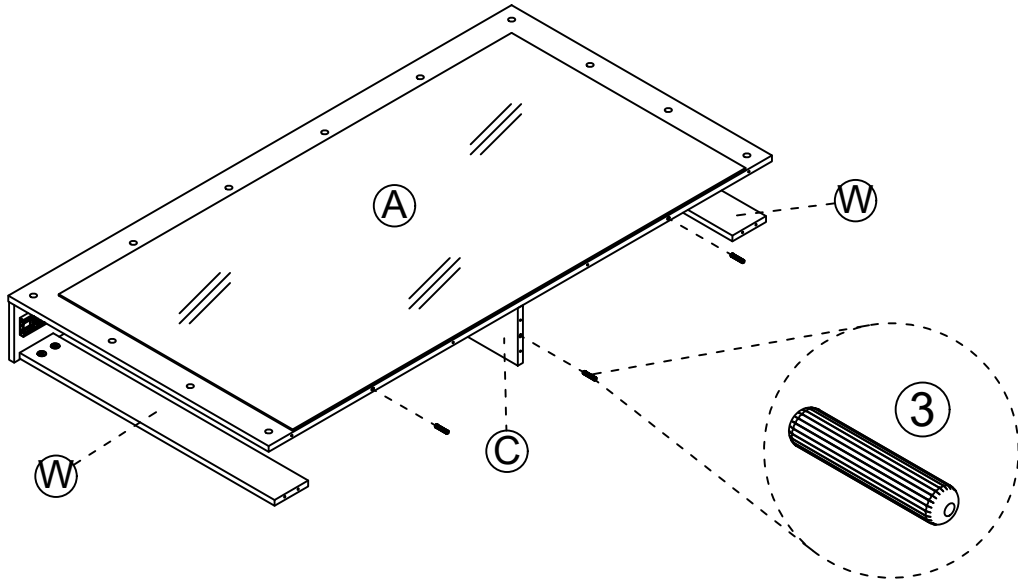
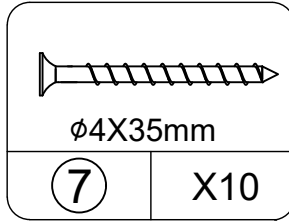
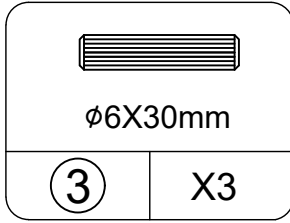
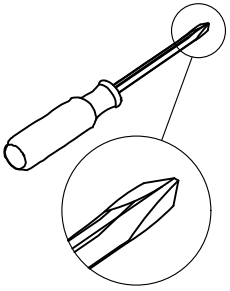

# STEP 28

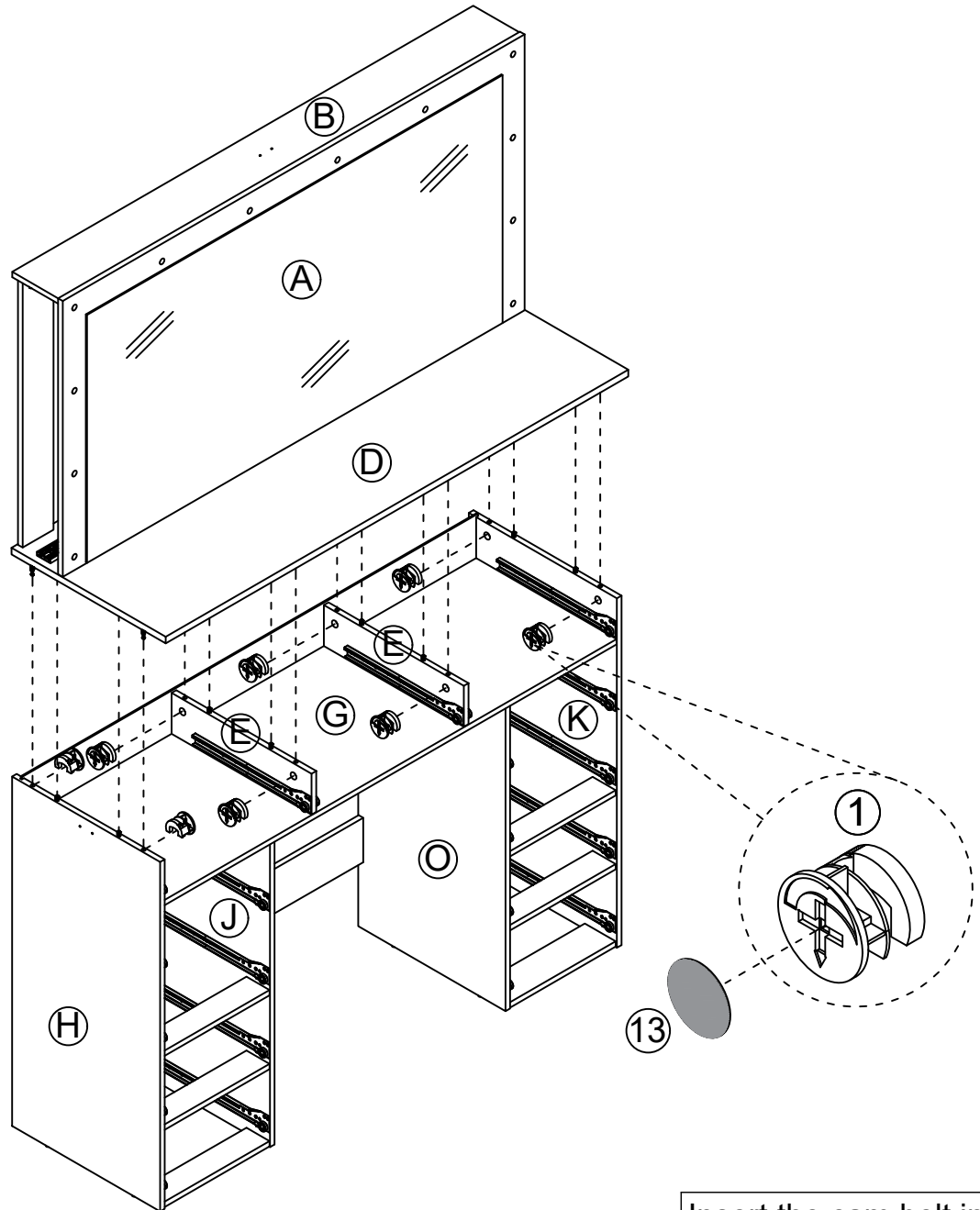
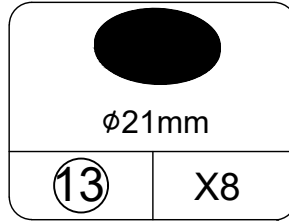
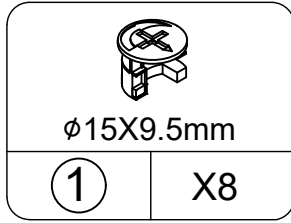
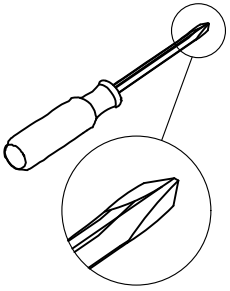

Insert the cam bolt into the hole first, then insert the cam lock and lock it.

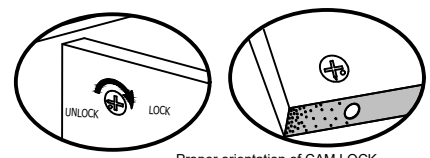

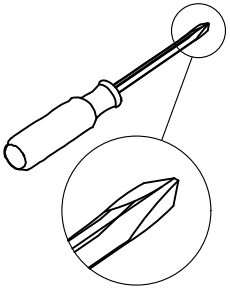

# STEP29

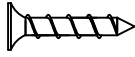

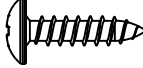
 ø3X12mm	
<b>4</b>	X2

 ø4X12mm	
<b>6</b>	X2

 109X99X38.5mm	
<b>11</b>	X1

 125X45X43mm	
<b>12</b>	X1

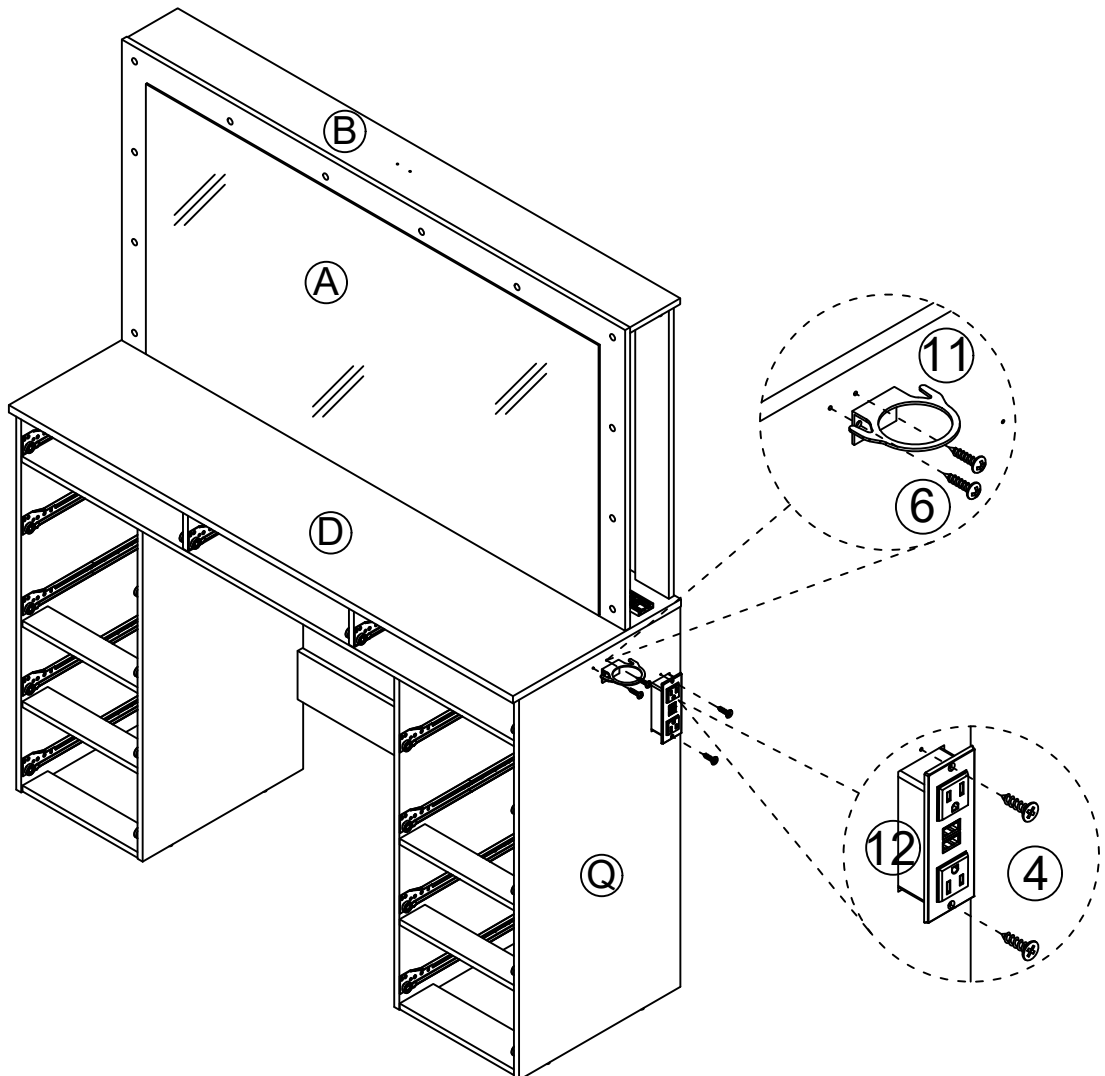

# STEP30

---

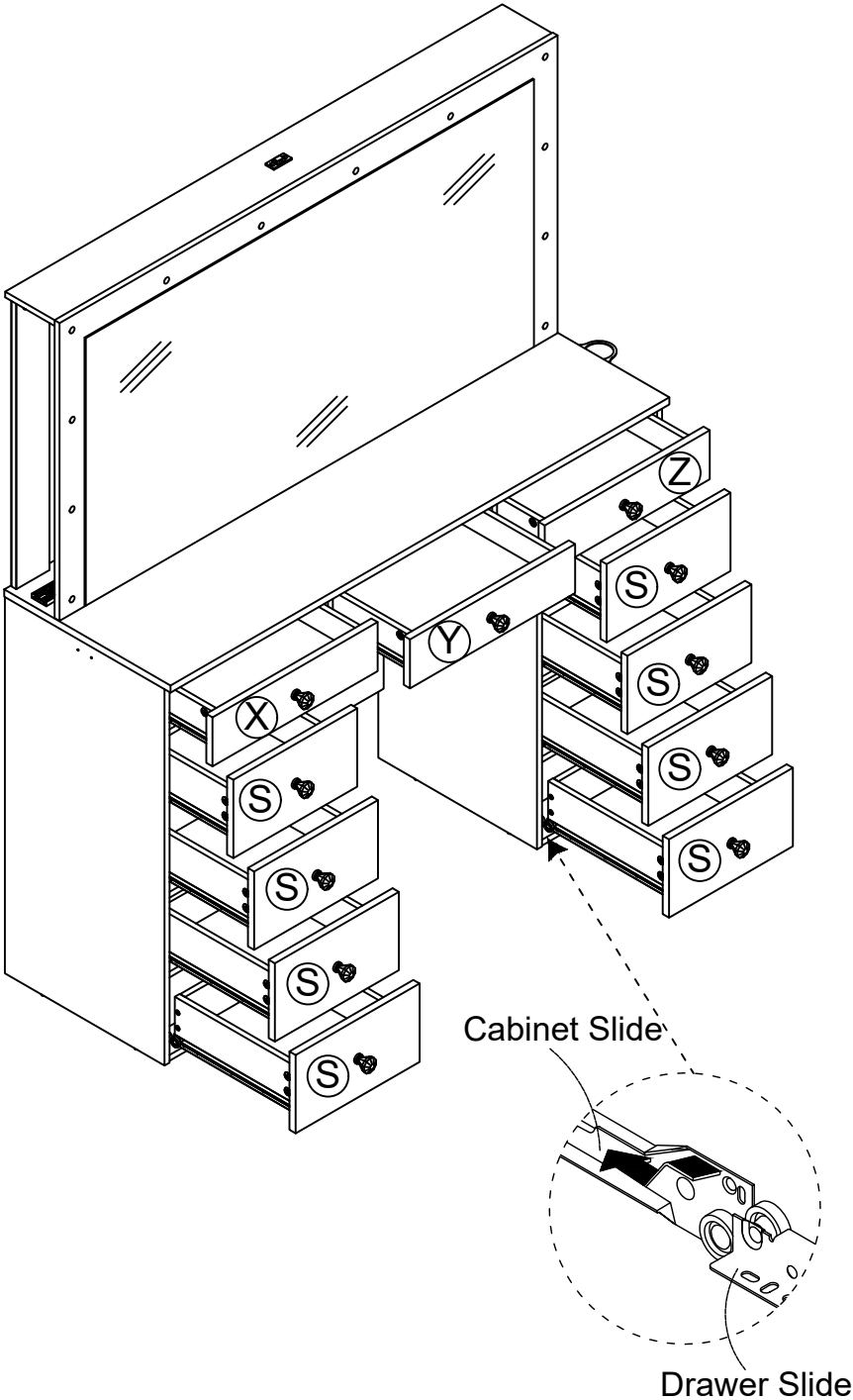

# STEP31

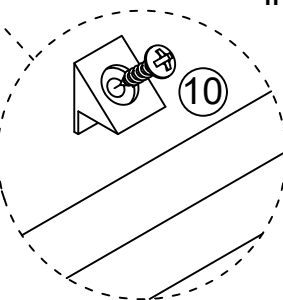
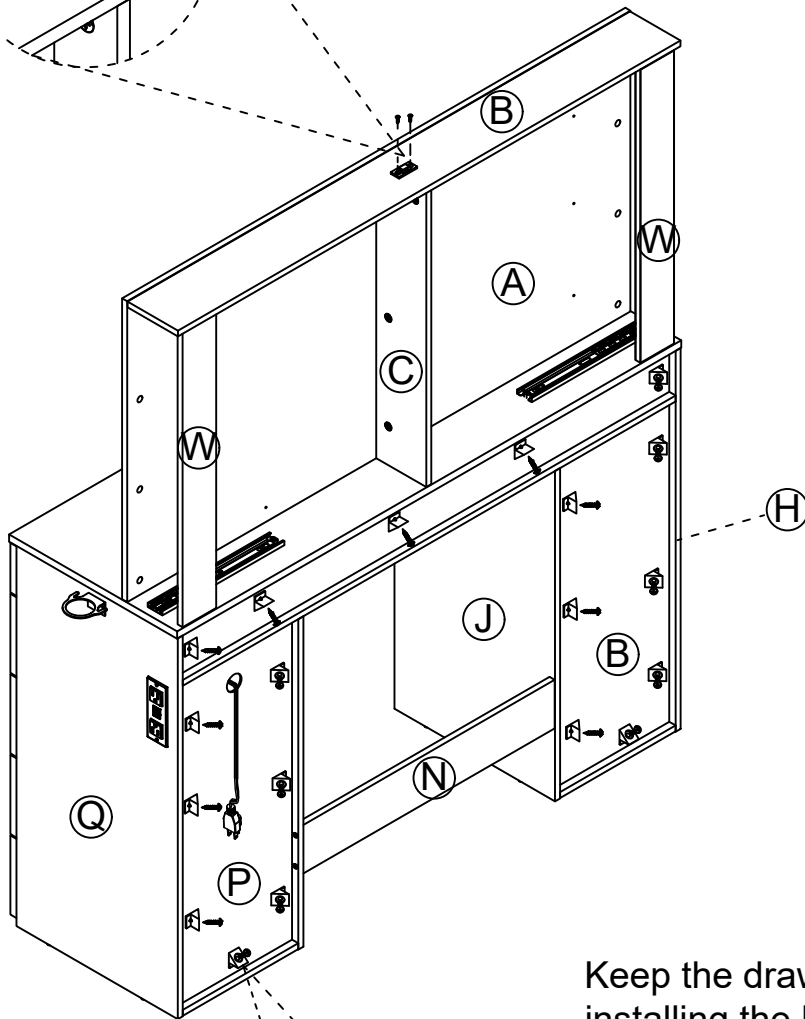
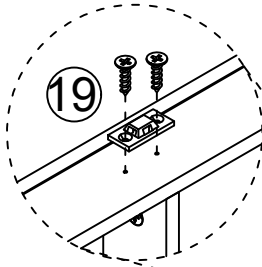
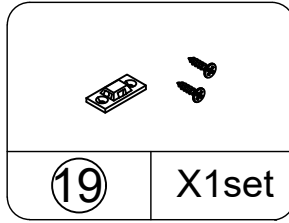
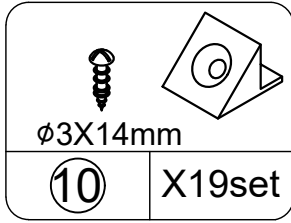
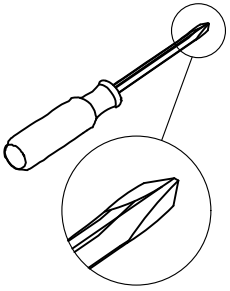

# STEP32

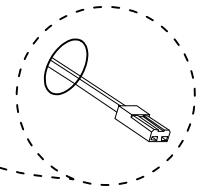
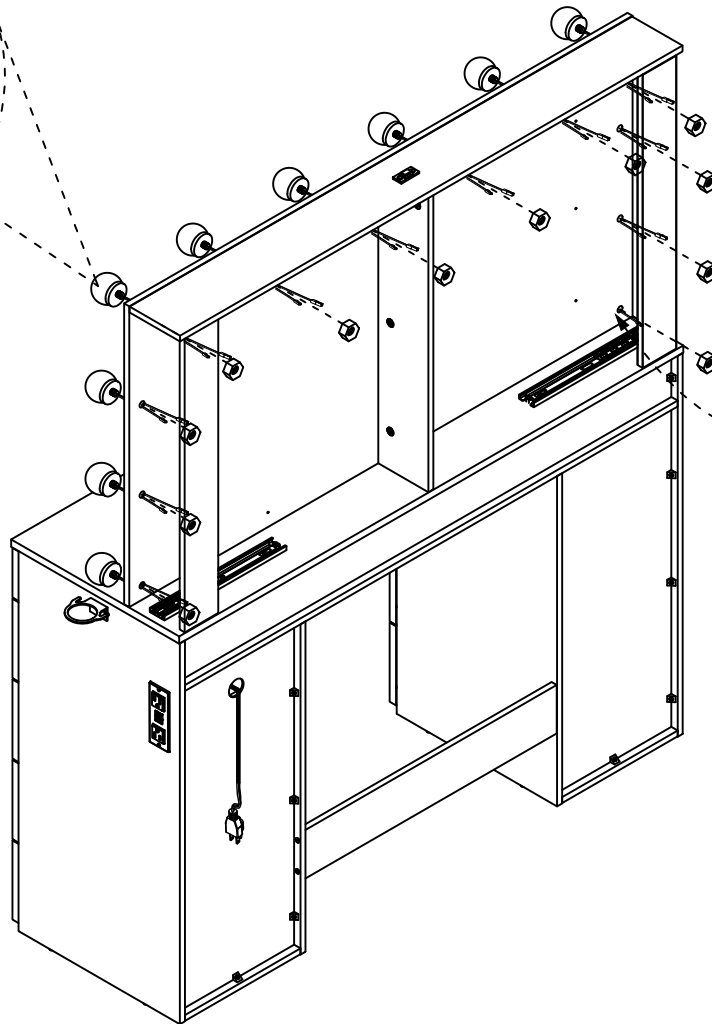
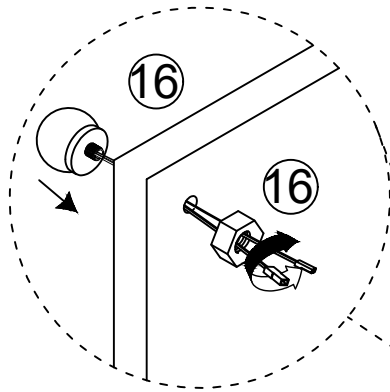
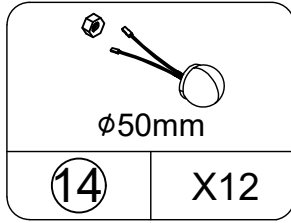
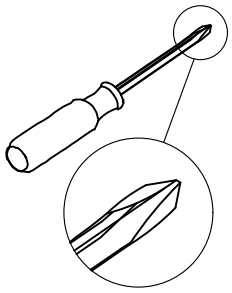

Note: The bulb with one wire is installed in the first hole.

# STEP33

Pass the bulb wire through the pre punched plate, then gently press the bulb and make it adhere to the plate, and then connect the adjacent bulbs successively through the wire head slot on the opposite side (corresponding to the line of the same color).

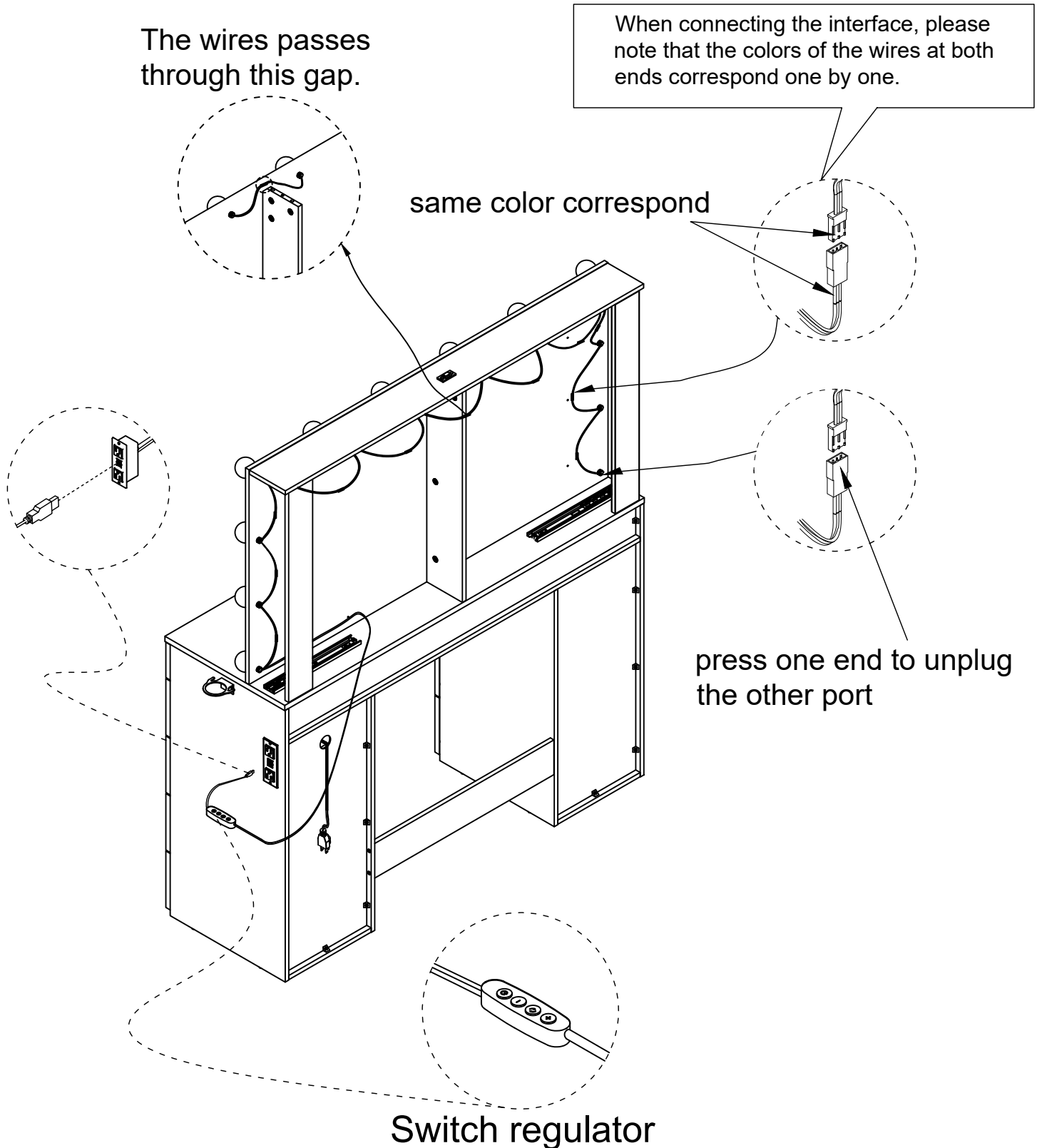

# STEP34

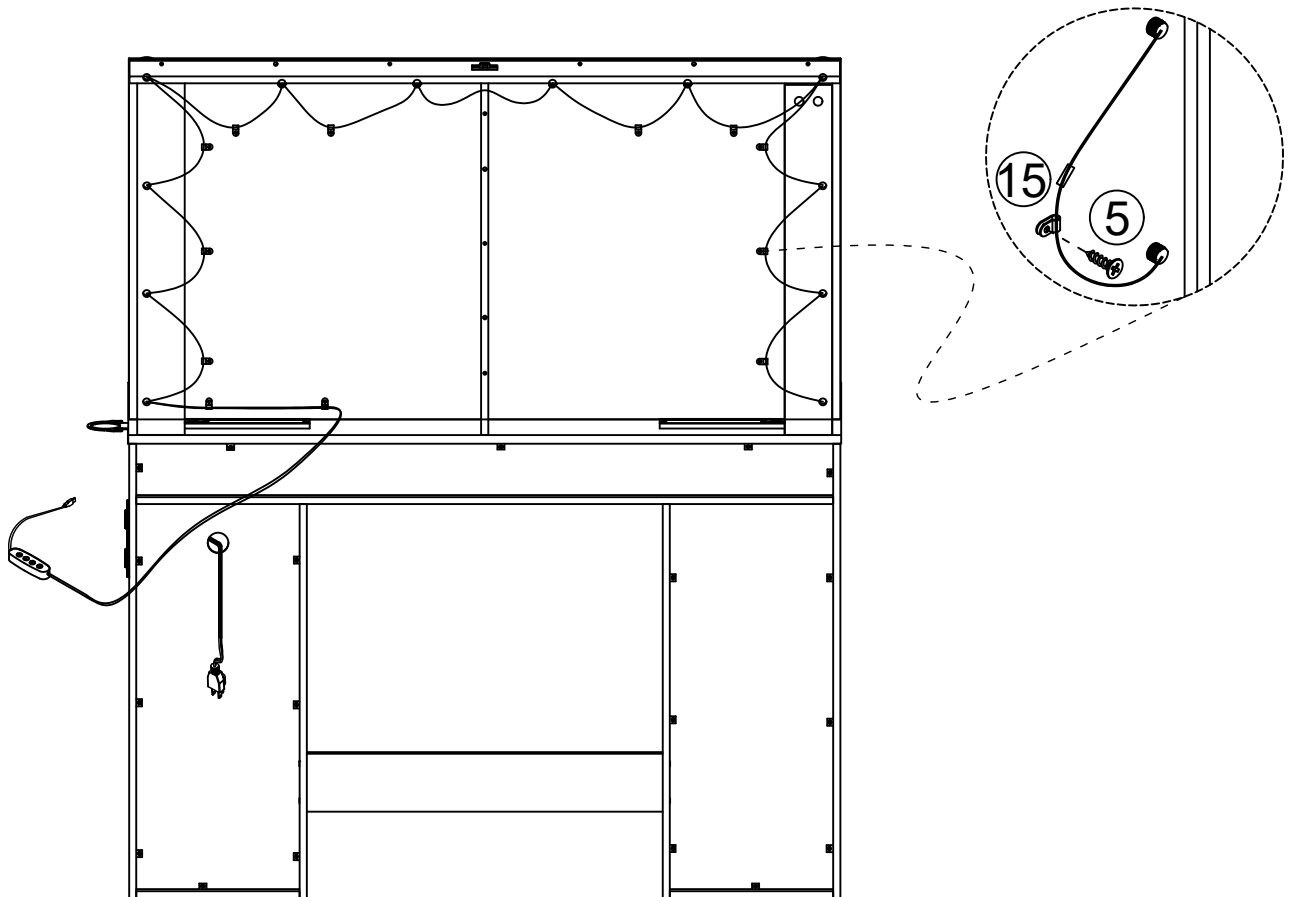
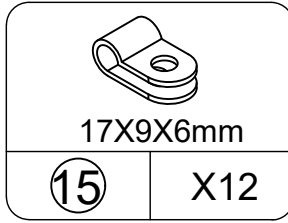
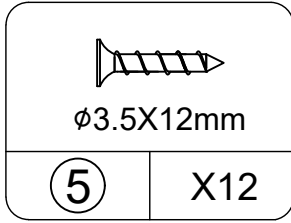
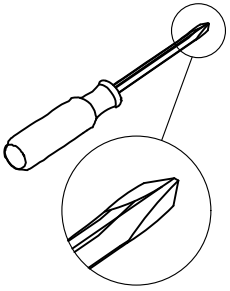

# STEP35

---

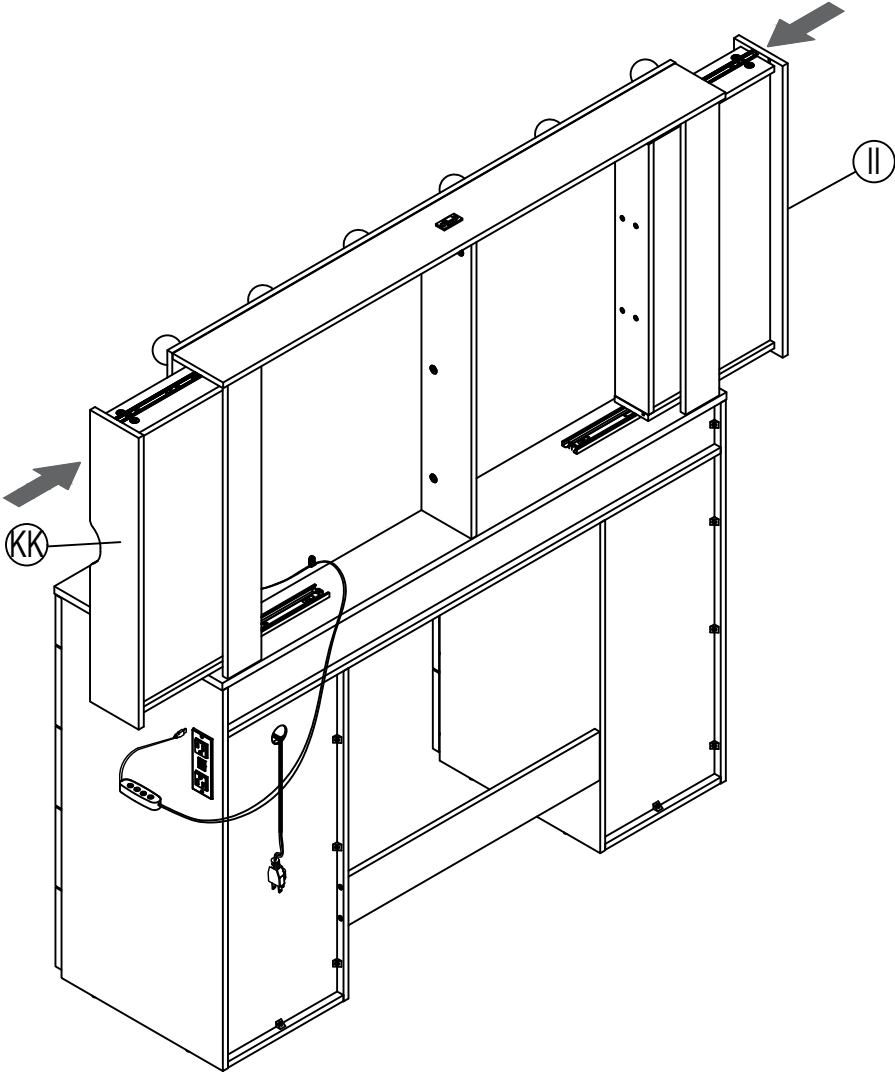

# STEP36

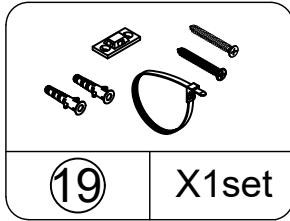
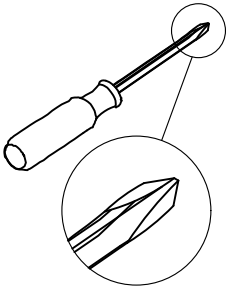

**NOTE:**The tipping restraint hardware included is for wooden stud wall construction. It must be attached to a wall stud. Depending upon your wall construction different anchor hardware may be required. Please contact your local hardware store for assistance. Young children can be seriously injured by tipping furniture. You must install the tipping restraint hardware with the unit to prevent the unit from tipping, causing any accidents or damage. The tipping restraints are intended only as a deterrent and are not a substitute for proper adult supervision. The tipping restraints are not earthquake restraints. If you wish to add the extra security of earthquake restraints, they must be purchased and installed separately.

## Install the tipping restraint hardware

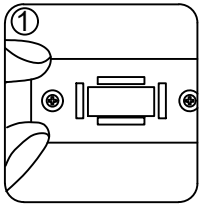

1. make mark on the wall

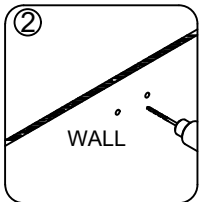

2. drill two Ø6 holes on the wall

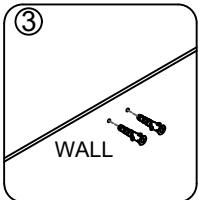

3. put two anchors in the holes

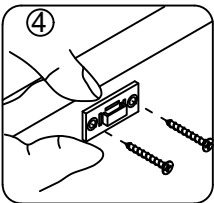

4. fix the device on the wall by the long screws

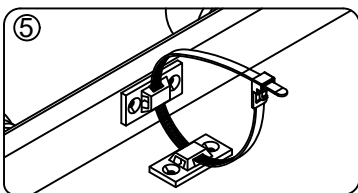

5. Push the cabinet close to the wall so that the two bases are close to each other, and then nylon tie to tighten it.

