

ASSEMBLY INSTRUCTIONS

2Door WC

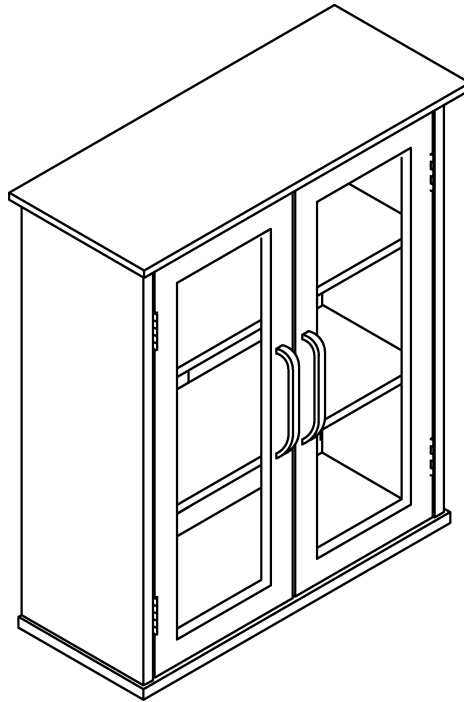

Please provide the following information when contacting for parts or questions: the name of the company you purchased from, the UPS/FedEx tracking number.

This product comes with a 1 year warranty. Products purchased second hand/used are not covered under the warranty.

ASSEMBLY INSTRUCTIONS-IMPORTANT

Carefully unpack & identify each component before attempting to assemble. Refer to parts list. Please take care when assembling the unit and always set the parts on a clean, soft surface. If you require any assistance with assembly, parts, please call the company you place order with or please email us.

INSTRUCCIONES PARA ARMAR-IMPORANT:







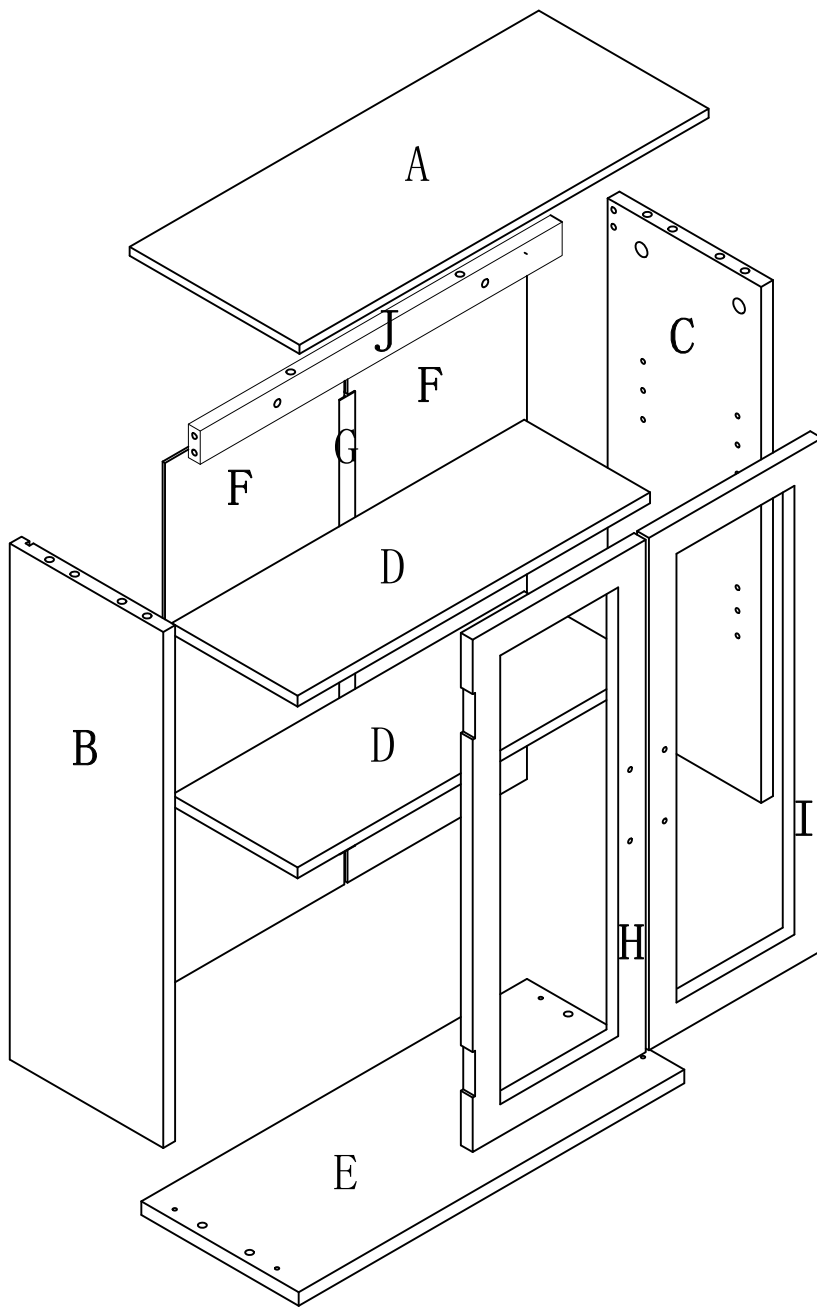



Desempaque e identifique cuidadosamente cada componente antes de intentar ensamblar. Consulte la lista de piezas. Tenga cuidado al ensamblar la unidad y siempre coloque las piezas en una superficie limpia y suave. Si necesita ayuda con el ensamblaje, piezas, llame a la compañía con la que realiza el pedido o envíenos un correo electrónico.

DIRECTIVES DE MONTAGE-IMPORTANT:











Déballiez et identifiez soigneusement chaque composant avant d'essayer de l'assembler. Se référer à la liste des pièces. Veuillez faire attention lors du montage de l'appareil et placez toujours les pièces sur une surface propre et douce. Si vous avez besoin d'aide pour l'assemblage, les pièces, veuillez contacter la société avec laquelle vous passez la commande ou envoyez-nous un e-mail.

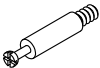

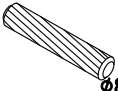
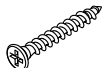
COMPONENTS

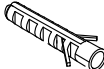
PART	FIGURE	DESCRIPTION	QTY	PART	FIGURE	DESCRIPTION	QTY
A		TOP PANEL	1PC	F		BACK PANEL	2PCS
B		LEFT SIDE PANEL	1PC	G		PLASTIC BAR	1PC
C		RIGHT SIDE PANEL	1PC	H		LEFT DOOR	1PC
D		ADJUSTABLE SHELF	2PCS	I		RIGHT DOOR	1PC
E		BOTTOM PANEL	1PC	J		UPPER BACK RAIL	1PC

HARDWARE & TOOLS

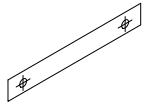
PART	FIGURE	DESCRIPTION	QTY	PART	FIGURE	DESCRIPTION	QTY
1	 ø15*12	CAM LOCK	8PCS	7		SHELF PIN	8PCS
2		CAM BOLT	8PCS	8	 ø3*12 D=7	SCREW	14PCS
3	 ø8*30	WOODEN DOWEL	14PCS	10	 ø4*35	SCREW	2PCS
4	 ø3*12	SCREW	8PCS	11		ANCHOR	2PCS
5		HANDLE BOLT	4PCS	12		CAM COVER	8PCS
6		HANDLE	2PCS			TEMPLATE PAPER	

TOOL NEEDED:



**PHILIPS SCREWDRIVER REQUIRED
- NOT INCLUDED**

SUGGESTION:

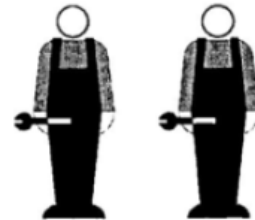

TWO PEOPLE FOR ASSEMBLING



WARNINGS:

1. DO NOT LET ANY SHARP OBJECTS TOUCH OR RUB THE SURFACE OF THE PRODUCT.
2. WHEN ASSEMBLING, DO NOT LET CHILDREN PLAY AROUND THE WORKING AREA.
3. PLEASE CONFIRM ALL PARTS ARE CORRECT BEFORE STARTING THE ASSEMBLY PROCESS.
4. DO NOT TIGHTEN ALL BOLTS AND SCREWS COMPLETELY UNTIL THE ENTIRE UNIT HAS BEEN ASSEMBLED AND SET UP.

1

1
4 PCS $\phi 15 \times 12$

2
4 PCS

3
8 PCS



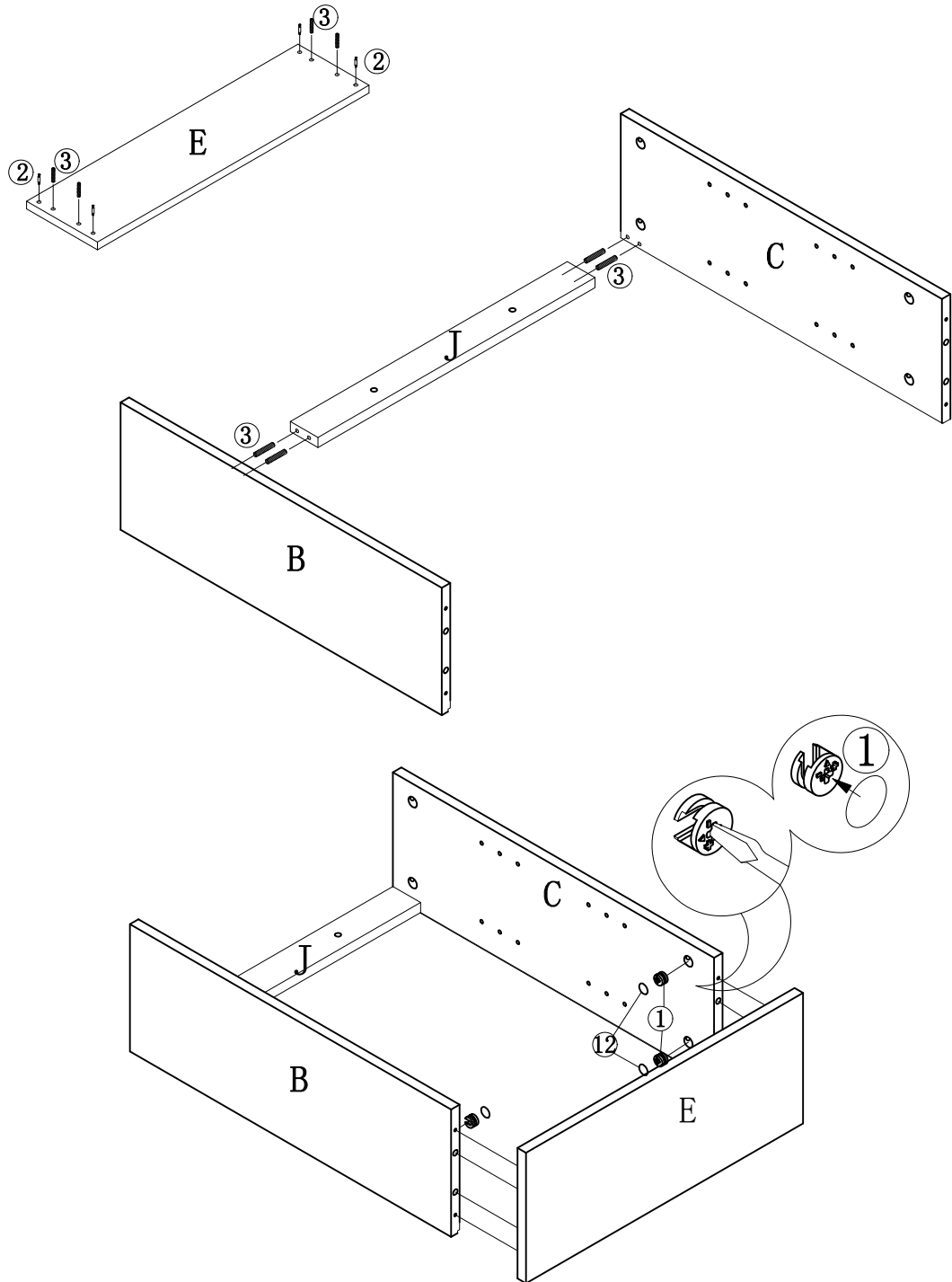

12
4 PCS



STEP 1:

1. Screw cambolts (2) and insert dowels(3) to panel E.
2. Attach rail J to panels B & C with dowels (3).
3. Attach panel E to panels B & C & secure with camlocks (1).

2

- 1  4 PCS $\phi 15 \times 12$
- 2  4 PCS
- 3  6 PCS
- 12  4 PCS

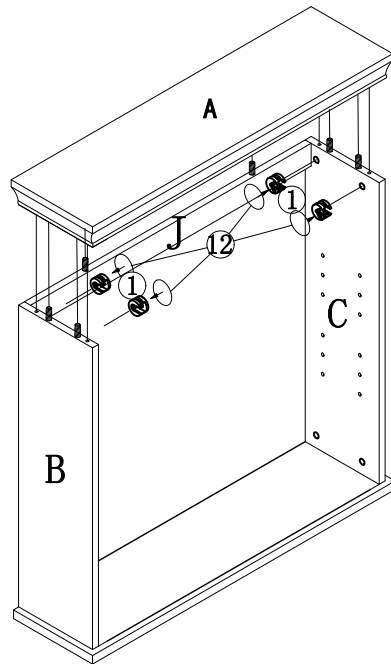
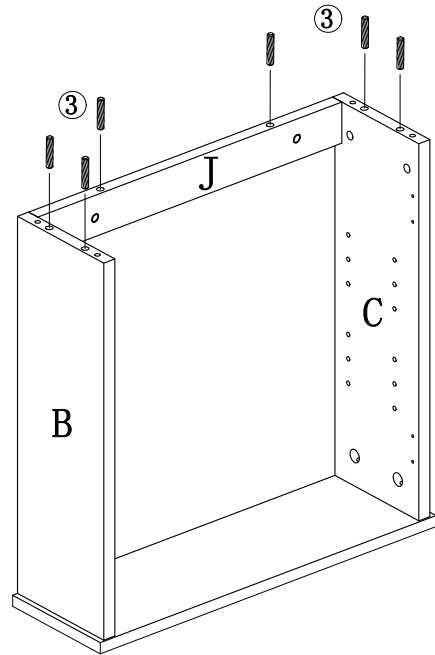
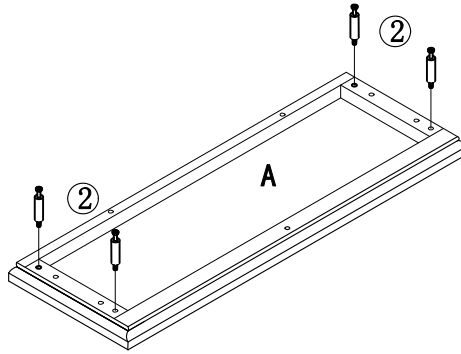

STEP 2:

1. Screw cambolts (2) to panel A.
2. Insert dowels (3) to the tops of panels B & C and rail J.
3. Attach panel A to panels B & C and rail J & secure with camlocks (1).

3

8



14 PCS $\phi 3 \times 12$ D=7

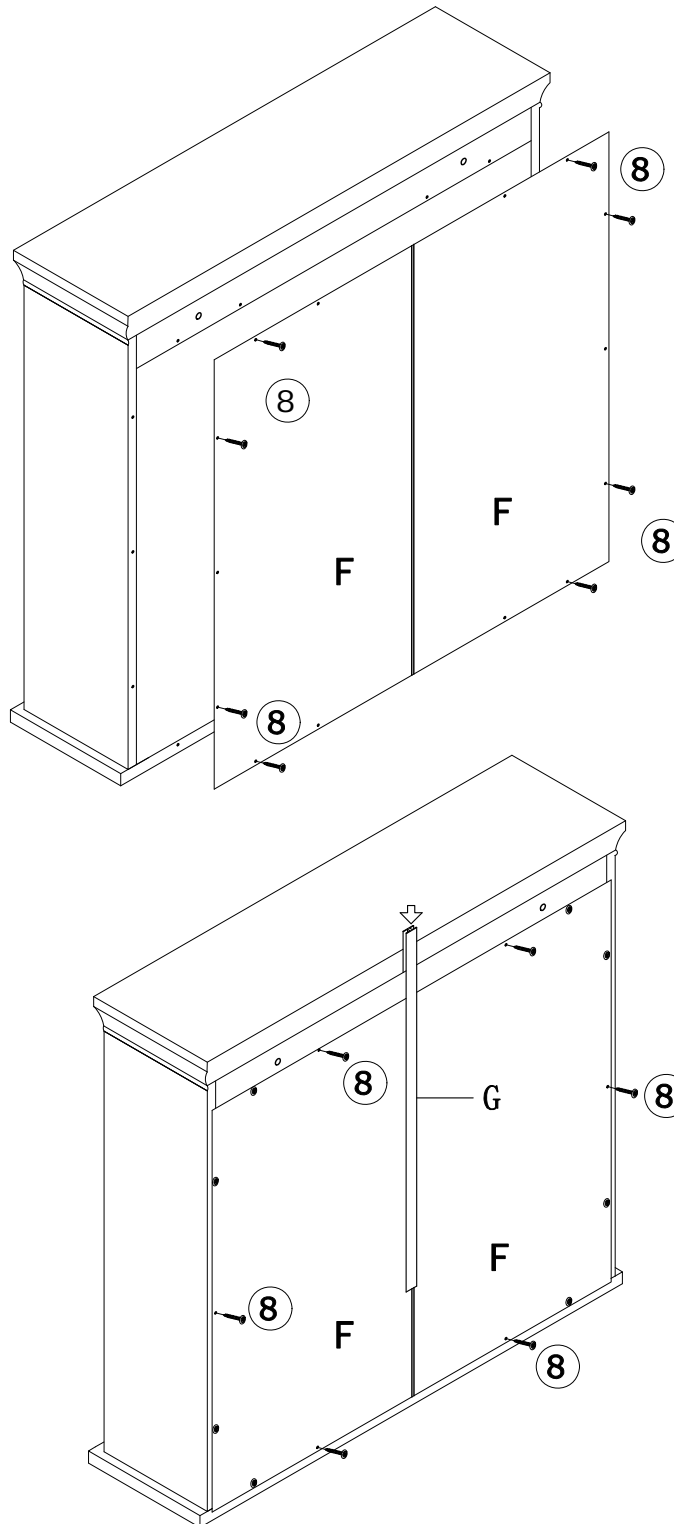

STEP 3:

1. Attach panels F to the back of the cabinet & secure the four corners with screws (8).
2. Insert plastic bar G between the two panel Fs and finish securing the panels with screw (8).

4

4
8 PCS
Ø3*12

5
4 PCS

6
2 PCS

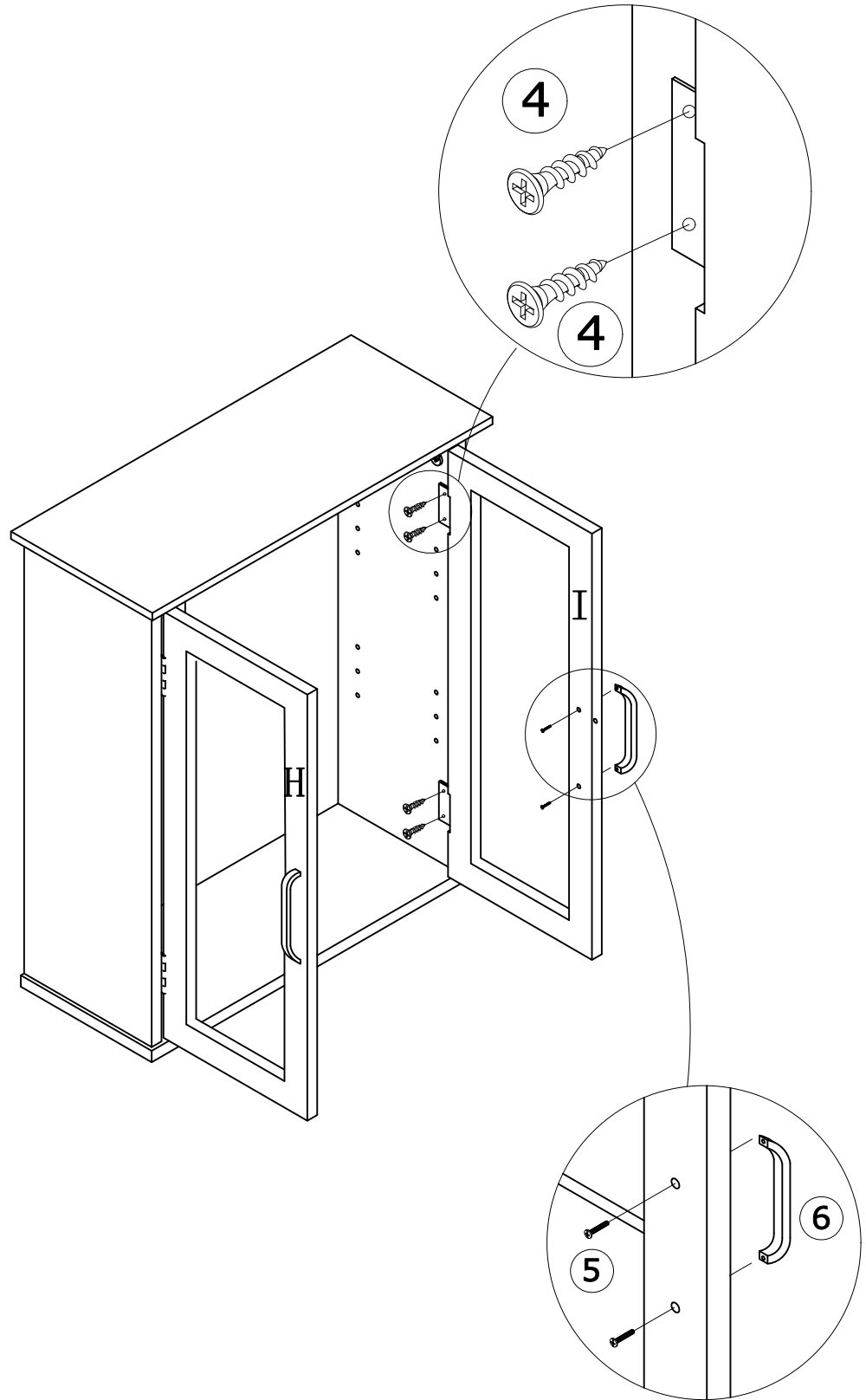

STEP 4:

1. Attach handles (6) to doors H & I with bolts (5).
2. Attach doors H & I with screws (4).

5

7



8 PCS

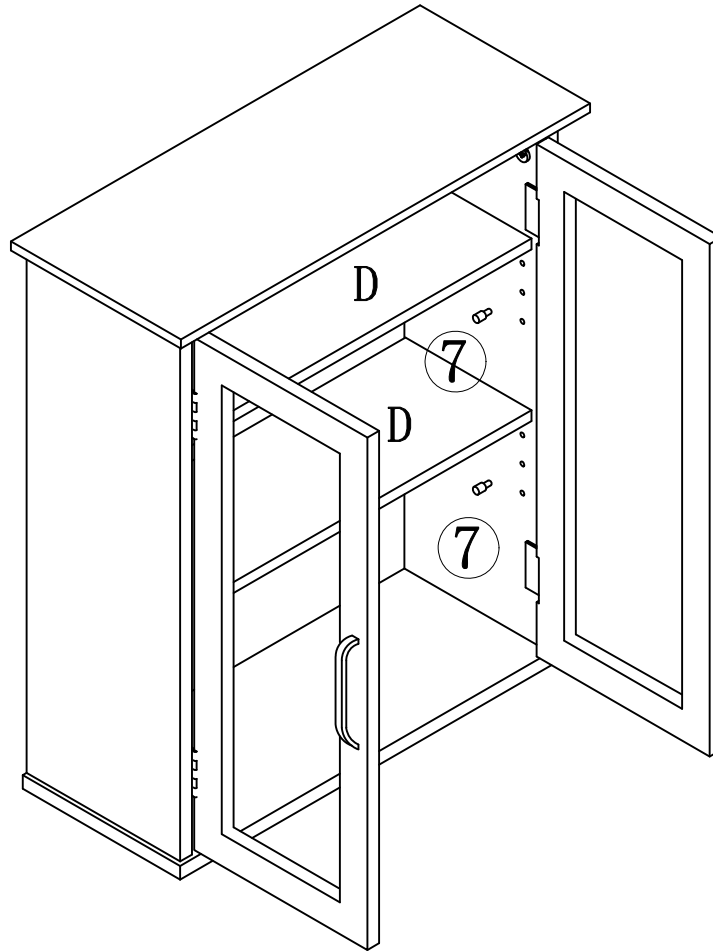

STEP 5:

1. Insert shelf pins (7) in panels B & C and rest the adjustable shelf D on the shelf pins.

6

10



2 PCS $\phi 4 \times 35$

11



2 PCS

