

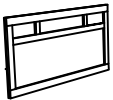

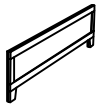







# ASSEMBLY INSTRUCTION

Thank you for purchasing the quality product. Be sure to check all packing material carefully for small parts which may have come loose inside the carton during shipment. Separate, identify and count all parts and metal hardware. Compare with all parts list to be sure all parts are present. If any part(s) are missing or damaged, please contact your local furniture dealer. For efficient and speedy service, please indicate the model number and code letter of parts(s) needed.

\*\*\*Do not fully tighten screws until fully assembled\*\*\*

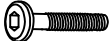
COMPONENT PARTS			
DESCRIPTION	PART NAME		Q'TY (PCS)
①	HEADBOARD		1
②	FOOTBOARD		1
③	HEADBOARG LEG		2
④	BED SLAT		4
⑤	BED SLAT SUPPORT		4
⑥	SIDE RAIL LEFT	 <i>Left Sticker</i>	2
⑦	SIDE RAIL RIGHT	 <i>Right Sticker</i>	2
⑧	BED SIDE RAIL LEG		2

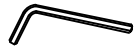
## HARDWARE REQUIRED (BOX OF HEADBOARD)

- (A)  BOLT 1/4" x 1 3/8" - 12 PCS
- (B)  SPRING WASHER 1/4" - 12 PCS
- (C)  FLAT WASHER 1/4" - 12 PCS
- (D)  ALLEN KEY M4 - 1 PC
- (E)  ALLEN KEY M5 - 1 PC
- (F)  FLATHEAD CHIPBOARD SCREW 5/32" x 1 2/8" - 16 PCS

Attention:

\*\*\* Some number parts listed in the instruction sheet may not be in parts bags as they already be assembled. Carefully check parts and packing materials prior to ordering replacements.

# How to assemble:

Step 1:

STEP 1.1 :

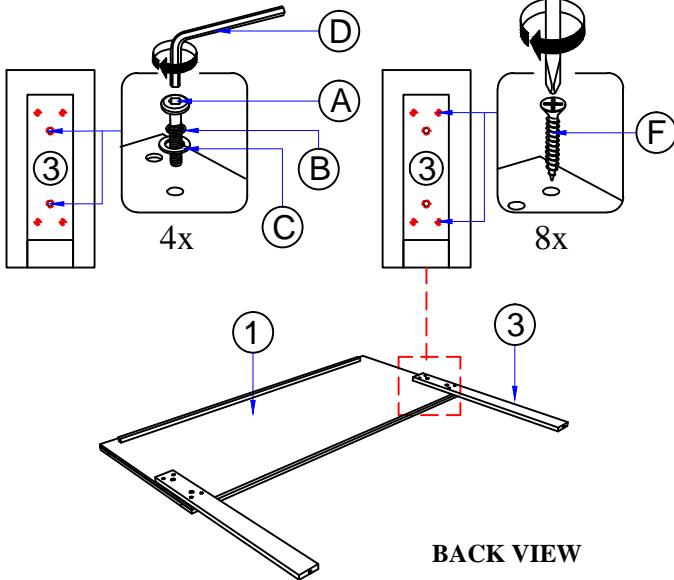

STEP 1.2 :

Step 2:

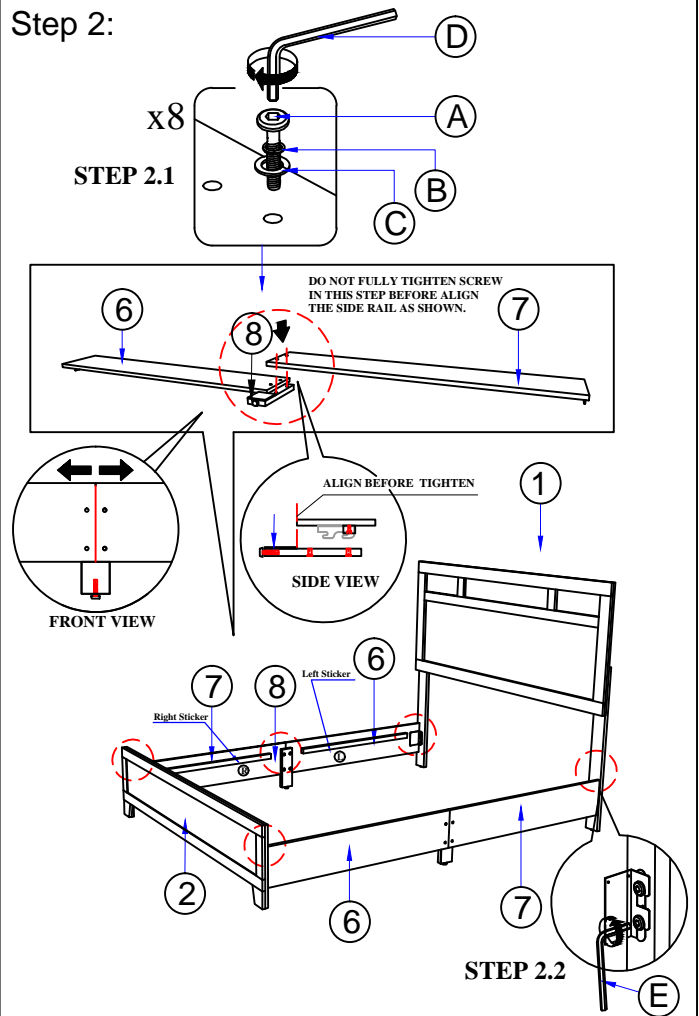

Step 3:

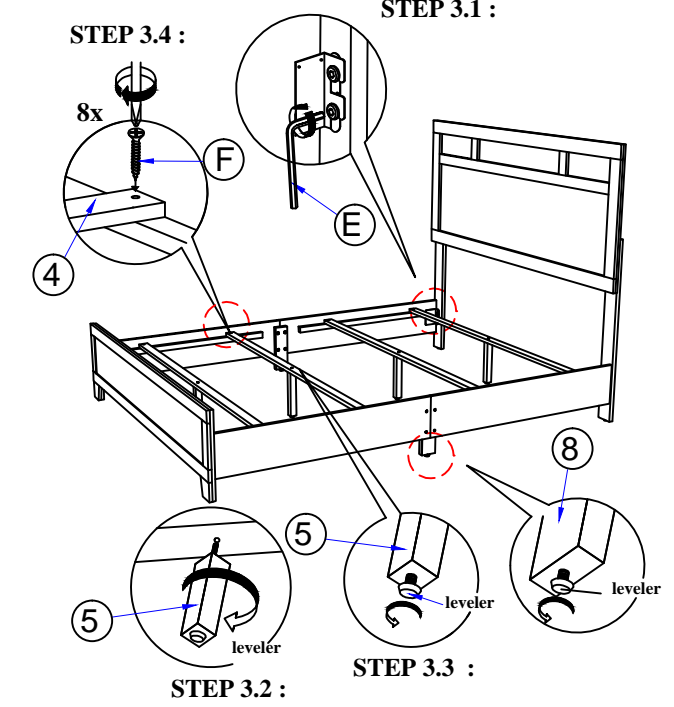

Step 4: COMPLETE

