

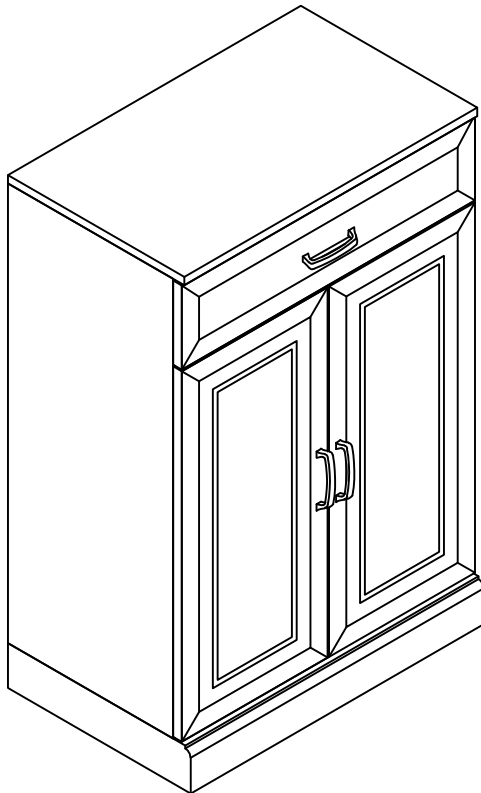





CROSLEY
FURNITURE

Storage Cabinet

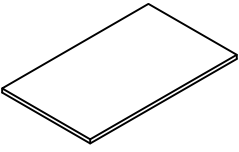

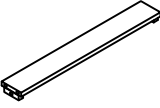
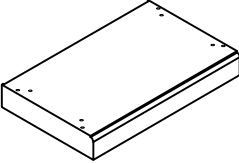
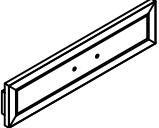

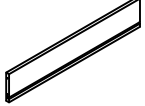
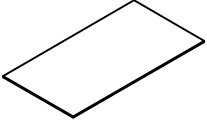

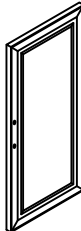
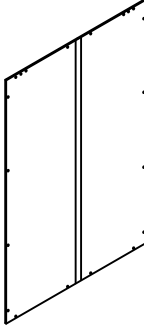
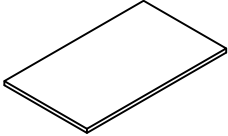



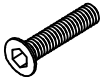

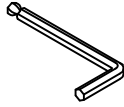
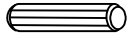
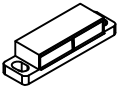
CF3121

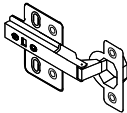

PART LIST

<p>A</p> 	<p>B</p> 	<p>C</p> 	<p>D2</p> 	<p>E</p> 
<p>Top Panel 1 PC</p>	<p>Left Panel 1 PC</p>	<p>Right Panel 1 PC</p>	<p>Cross Rail 1 PC</p>	<p>Bottom Panel 1 PC</p>
<p>F</p> 	<p>G2</p> 	<p>H2</p> 	<p>I2</p> 	<p>J2</p> 
<p>Drawer Front Panel 1 PC</p>	<p>Drawer Left Panel 1 PC</p>	<p>Drawer Right Panel 1 PC</p>	<p>Drawer Back Panel 1 PC</p>	<p>Drawer Bottom Panel 1 PC</p>
<p>K</p> 	<p>L</p> 	<p>M2</p> 	<p>N2</p> 	
<p>Left Door Panel 1 PC</p>	<p>Right Door Panel 1 PC</p>	<p>Back Panel 1 PC</p>	<p>Adjustable Shelf 1 PC</p>	

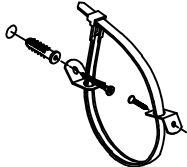
HARDWARE LIST

 Ø1/4"*25mm	 Ø1/4"*11mm	 Ø1/4"*13mm	 4mm*90	 Ø8*30mm
Bolt 10 PCS (Extra 1)	Spring Washer 10 PCS (Extra 1)	Flat Washer 10 PCS (Extra 1)	Allen Wrench 1 PC	Wood Dowel 12 PCS (Extra 1)
	 6*3*15mm		 7*3.5*15mm	
Magnet 1 PC	Round Head Screw 2 PCS (Extra 1)	Door Hinge 4 PCS	Screw 24 PCS (Extra 1)	Handle 3 PCS
 5/32"*19mm	 5/32"*15mm		 8*3*12mm	
Long Round Head Bolt 4 PCS (Extra 1)	Short Round Head Bolt 2 PCS (Extra 1)	Shelf Holder 4 PCS (Extra 1)	Short Screw 16 PCS (Extra 1)	Safety Strap Kit 1 SET
 8*4*25				
Long Screw 8 PCS (Extra 1)				

ADDITIONAL TOOLS (Not Provided)

Note: It is not recommended to use power tools during assembly.

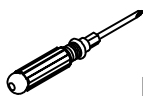

Phillips Head Screwdriver

Note: Wood dowels are intended for alignment. Additional clearance between wood dowel and pre-drilled hole is intentional for ease of assembly.

Step 1. Attach magnet (part #6) to cross rail (part D2) using round head screws (part #7) and phillips head screwdriver. Attach handle (part #10) to drawer front panel (part F) using short round head bolts (part #12) and phillips head screwdriver.

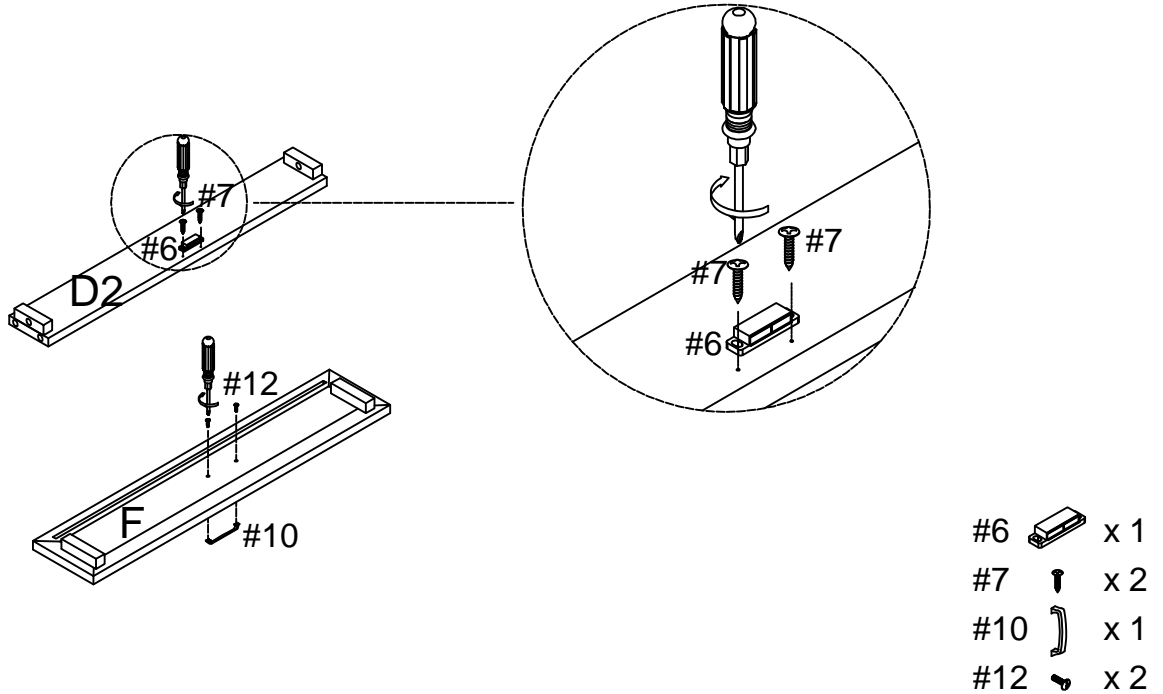

Step 2. Attach door hinges (part #8) to left door panel (part K) and right door panel (part L) using screws (part #9) and phillips head screwdriver. Attach handles (part #10) to left door panel (part K) and right door panel (part L) using long round head bolts (part #11) and phillips head screwdriver.

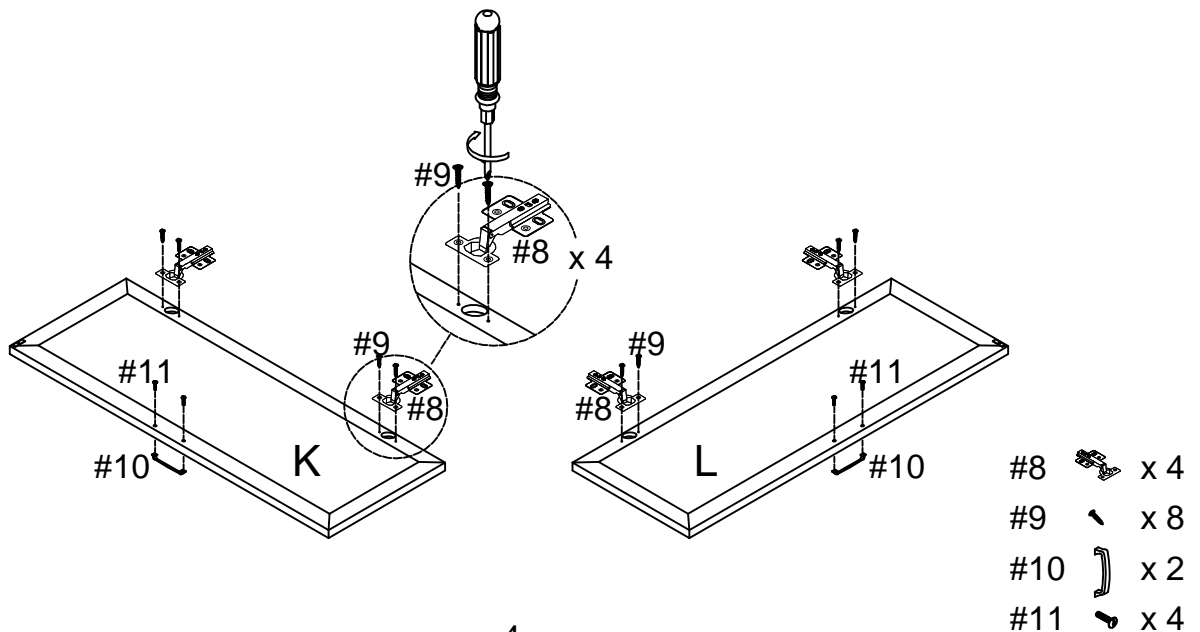

Step 3. Attach drawer panels (parts G2 & H2) to drawer front panel (part F) using long screws (part #16) and phillips head screwdriver. Slide drawer bottom panel (part J2) into the grooves of assembled unit (parts F, G2 & H2). Attach drawer back panel (part I2) to assembled unit (parts G2, H2 & J2) using long screws (part #16) and phillips head screwdriver.

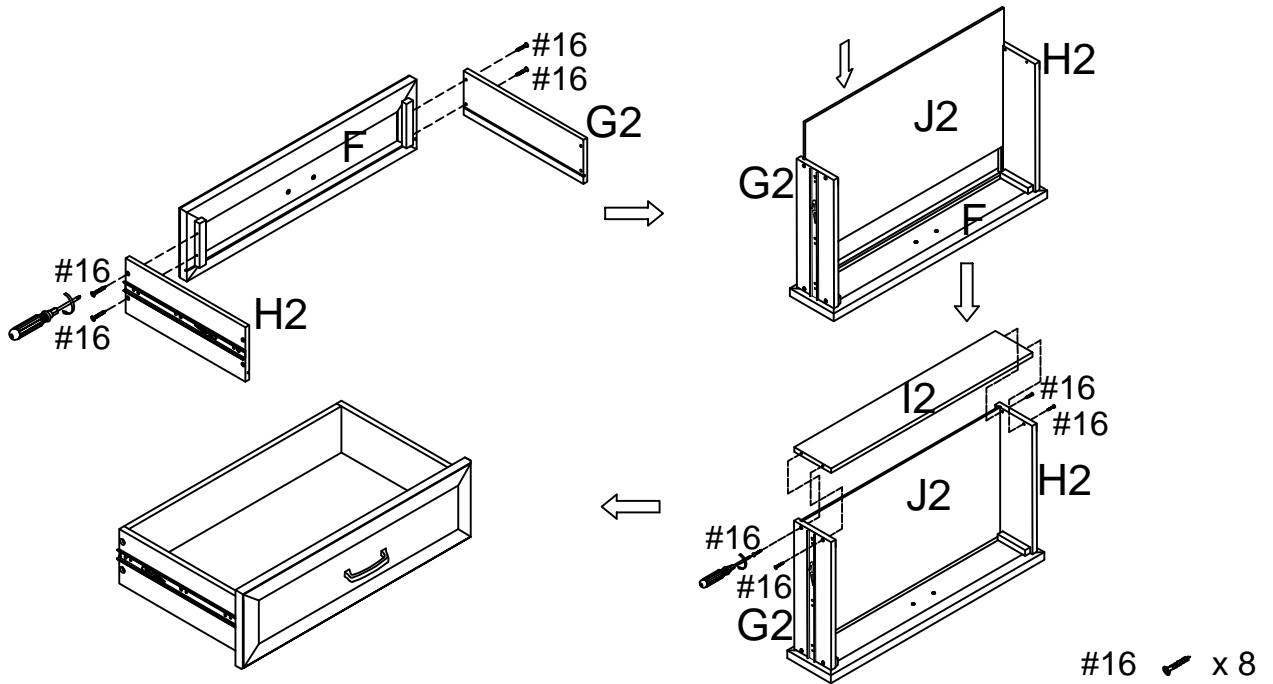

Step 4. Attach cross rail (part D2) to left panel (part B) and right panel (part C) using wood dowels (part #5), bolts (part #1), spring washers (part #2), flat washers (part #3) and allen wrench (part #4).

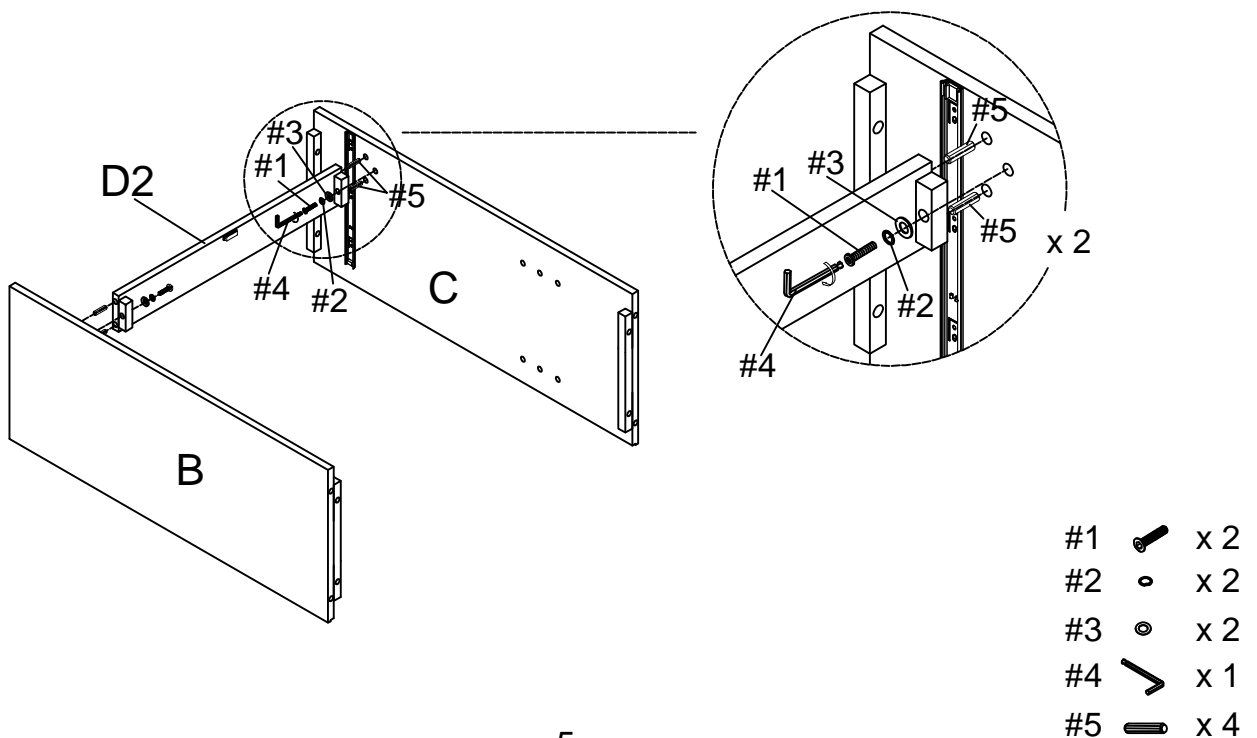

Step 5. Attach top panel (part A) to assembled unit (parts B & C) using wood dowels (part #5), bolts (part #1), spring washers (part #2), flat washers (part #3) and allen wrench (part #4).

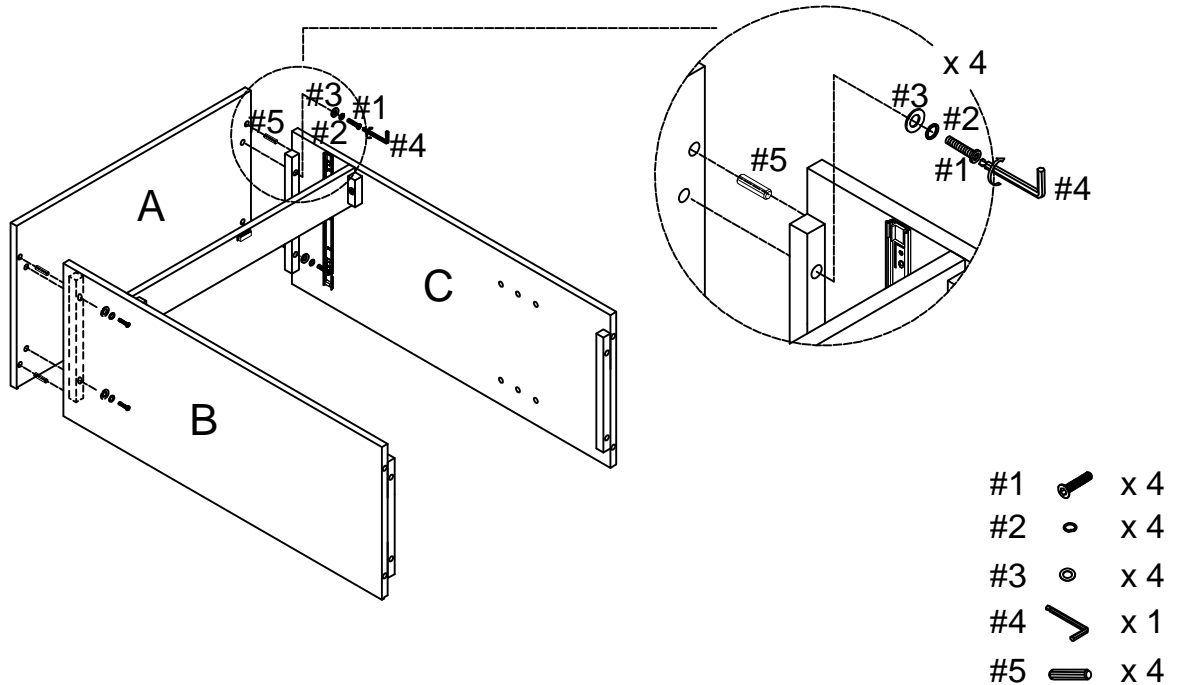

Step 6. Attach bottom panel (part E) to assembled unit (parts B & C) using wood dowels (part #5), bolts (part #1), spring washers (part #2), flat washers (part #3) and allen wrench (part #4).

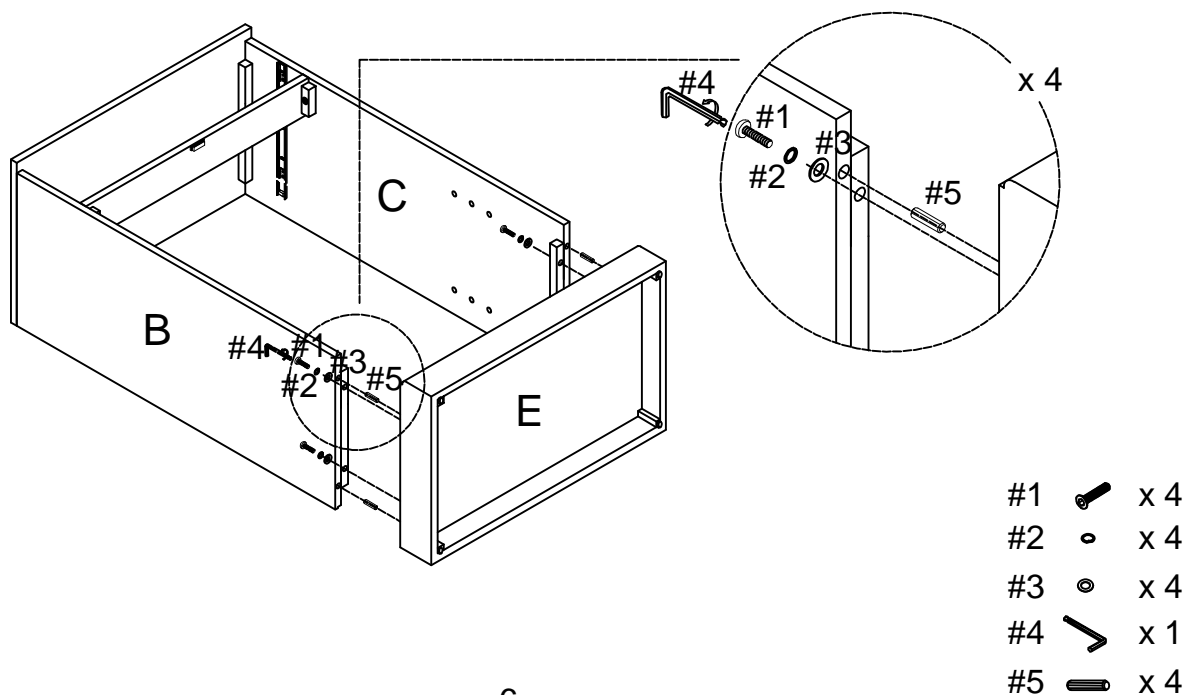

Step 7. Carefully turn unit upright. Attach back panel (part M2) to assembled unit (parts A, B, C & E) using short screws (part #14) and phillips head screwdriver.

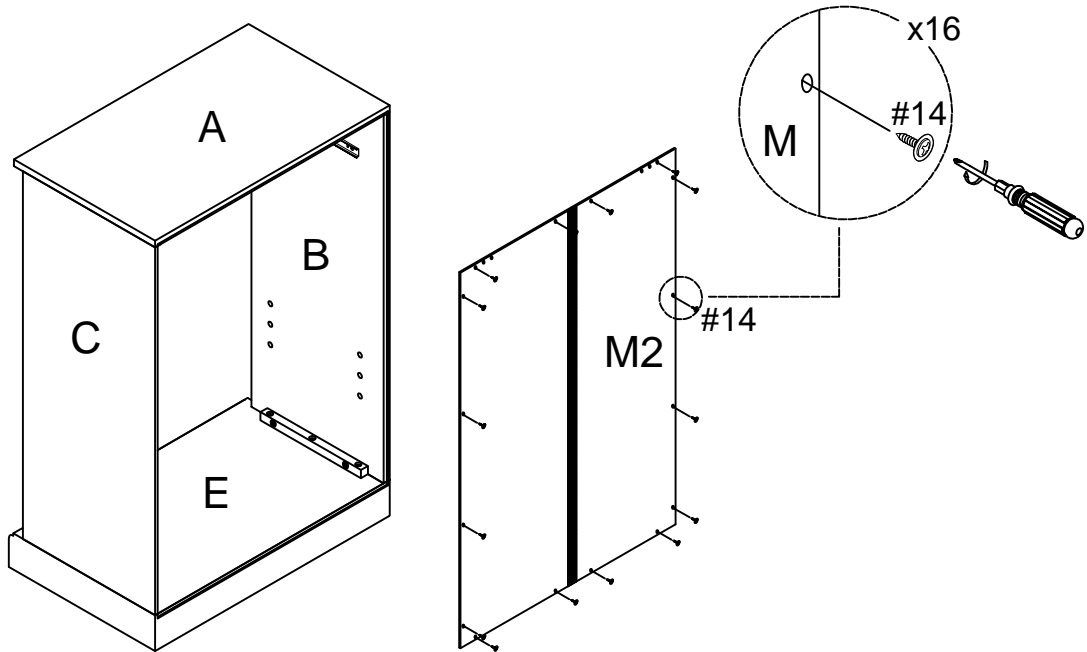

#14  x 16

Step 8. Place shelf holders (part #13) into desired position and slide adjustable shelf (part N2) and assembled drawer into place.

Note: To release trigger disconnect levers push one side up and the other down.

Move the sliders to the front end of rail before sliding the drawer into place.

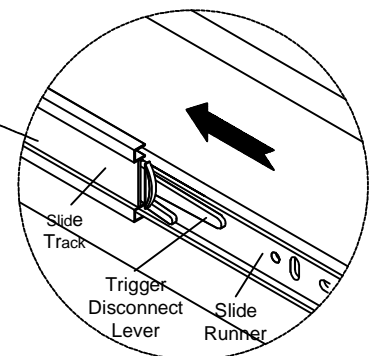
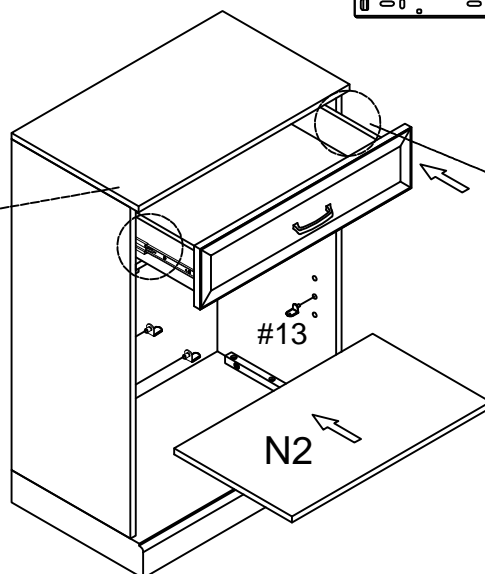
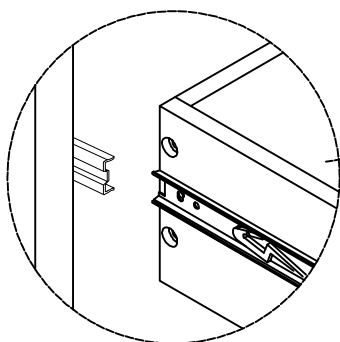
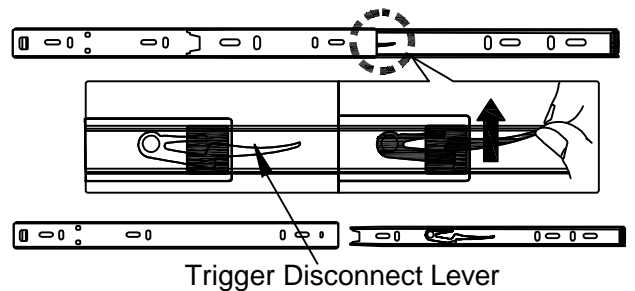





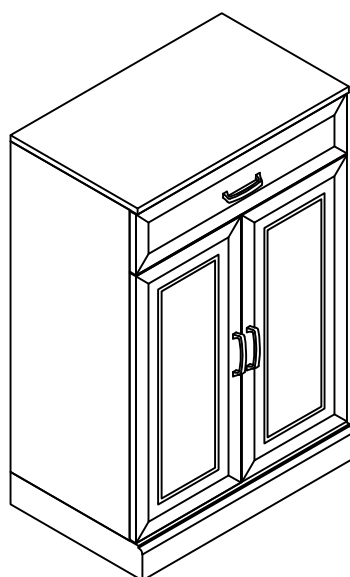
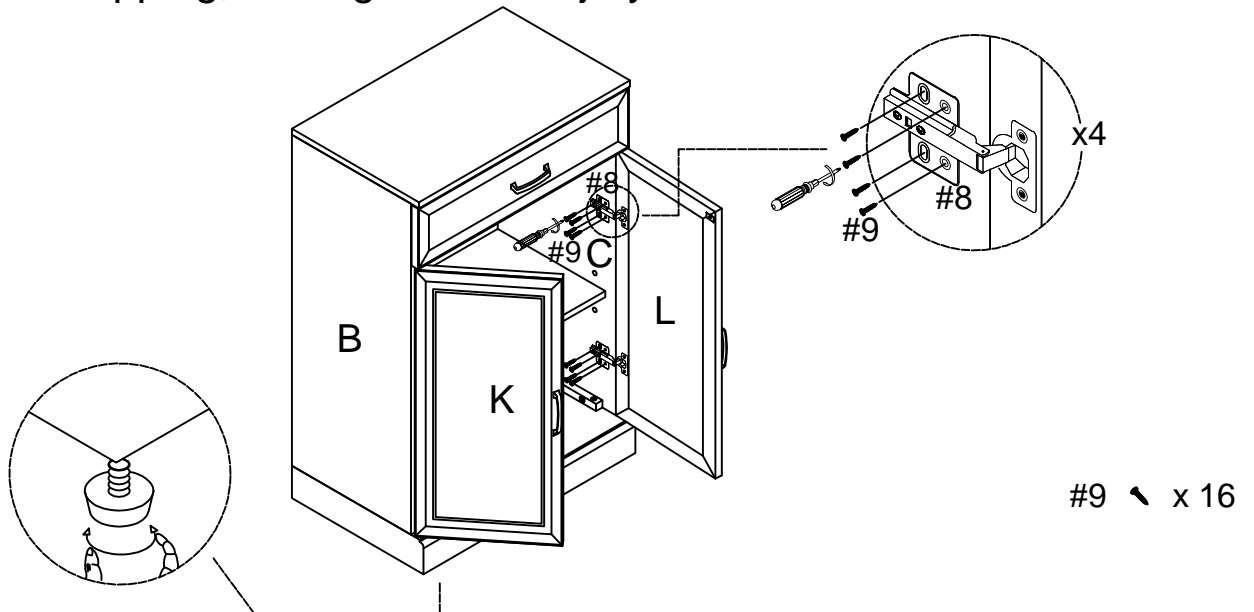

#13  x 4

Step 9. Attach door panels (parts K & L) to panels (parts B & C) using screws (part #9) and phillips head screwdriver.

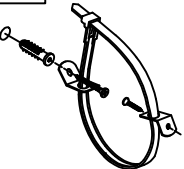
NOTE: It is important to adjust levelers once fully assembled and upright. Extend adjustable leveler until it's firmly in contact with the floor. If relocating, adjust leveler as needed until it's firmly in contact with the floor in new location.

Important: Safety strap kit (part #15) must be installed to prevent tipping, damage and/or injury.



#15	A	B	C	D	E
					
			8*3*15mm	8*4*35mm	
Safety Strap Kit 1 SET	Wall Anchor 1 PC	Bracket 2 PCS	Short Screw 1 PC	Long Screw 1 PC	Safety Wall Strap 1 PC



SAFETY WALL STRAP INSTALLATION

Note: It is highly recommended to install this safety strap kit to prevent tipping, damage and/or injury.

1. Insert short screw (C) and safety wall strap (E) through bracket (B) and attach to top panel (part A) using phillips head screwdriver.
2. Drill a 11/32" hole where you want to secure the unit. The drilled hole will be at the same height as the hole in top panel (part A) where bracket (B) is attached. Tap wall anchor (A) into the hole.
3. Insert long screw (D) and safety wall strap (E) through bracket (B) into wall anchor (A) using phillips head screwdriver.

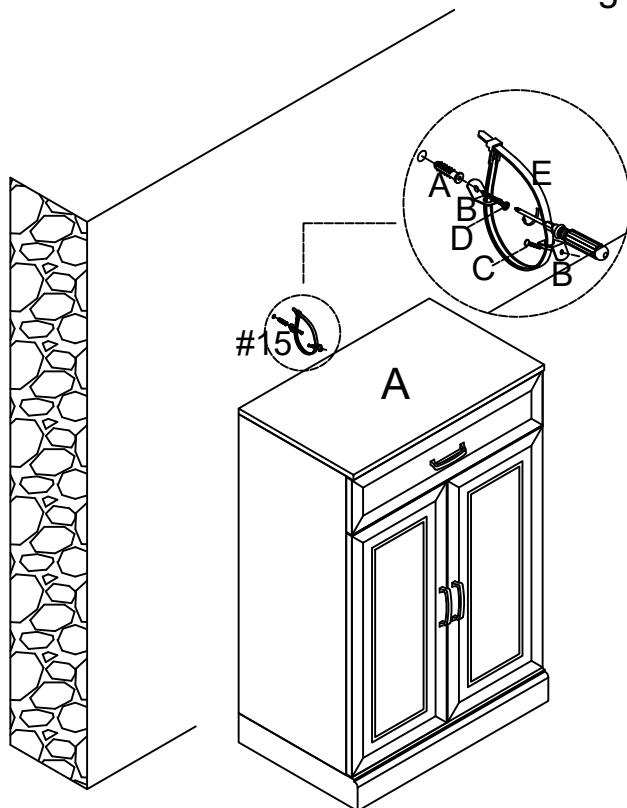
Note: This item is not intended for clothing storage use.



▲WARNING	
	Children have died from furniture tipover. To reduce the risk of furniture tipover:
	<ul style="list-style-type: none"> • ALWAYS install tipover restraint provided. • NEVER put a TV on this product. • NEVER allow children to stand, climb or hang on drawers, doors, or shelves. • NEVER open more than one drawer at a time. • Place heaviest items in the lowest drawers.
This is a permanent label. Do not remove!	

ADJUST YOUR DOORS TO MAKE THE GAPS MORE EVEN (OPTIONAL).

STEP 1

Open the door.

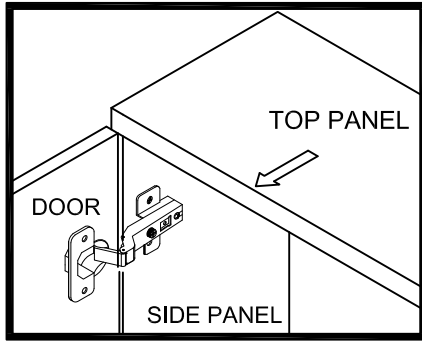

STEP 2

Adjust the gap between door panel and side panel

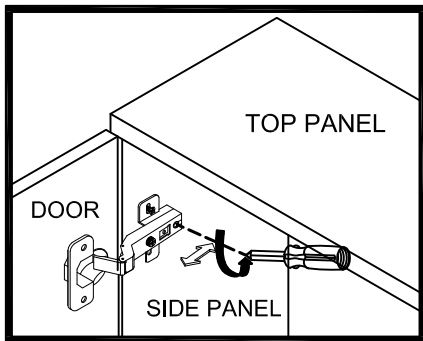

Loosen the screw indicated a little, adjust the hinge to right position (see step 2a & 2b), then tighten the screw.

STEP 2a MOVE DOOR IN

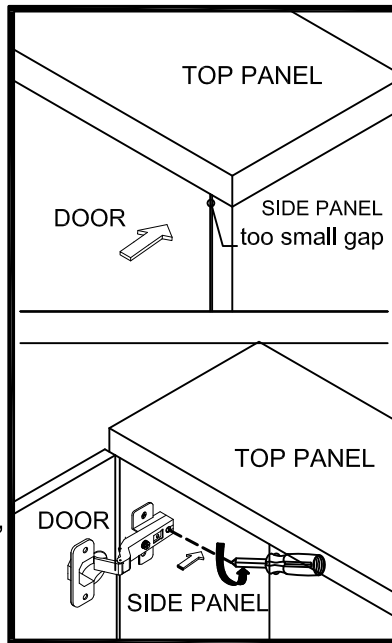

Push the hinge back a little.

STEP 2b MOVE DOOR OUT

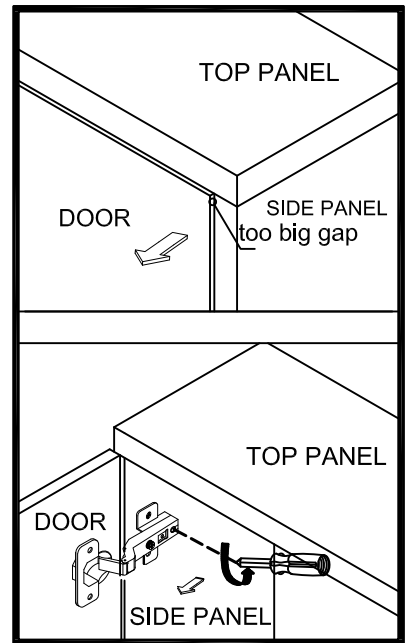

Pull the hinge forward a little.

STEP 3

To adjust the gap between two door

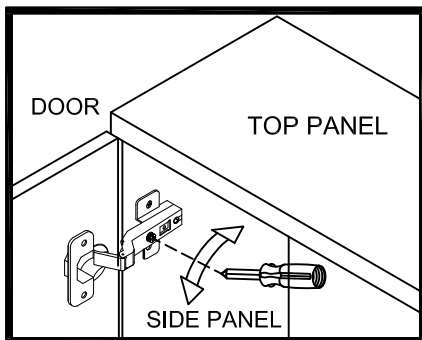

Loosen or tighten the screw indicated a little to adjust the gap between doors panels (see step 3a & step 3b)

STEP 3a MOVE DOOR RIGHT

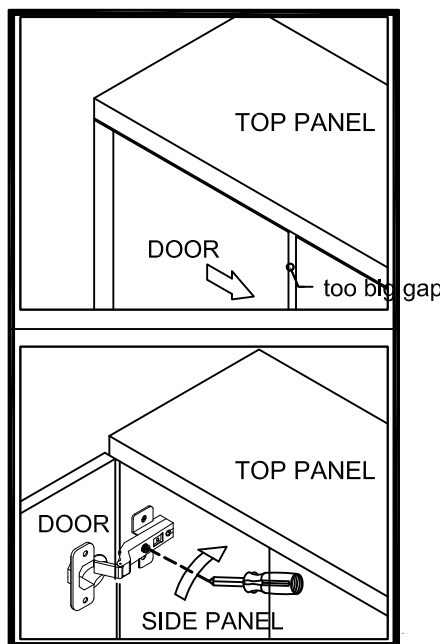

Turn the screw clockwise a little as shown to make the gap small.

STEP 3b MOVE DOOR LEFT

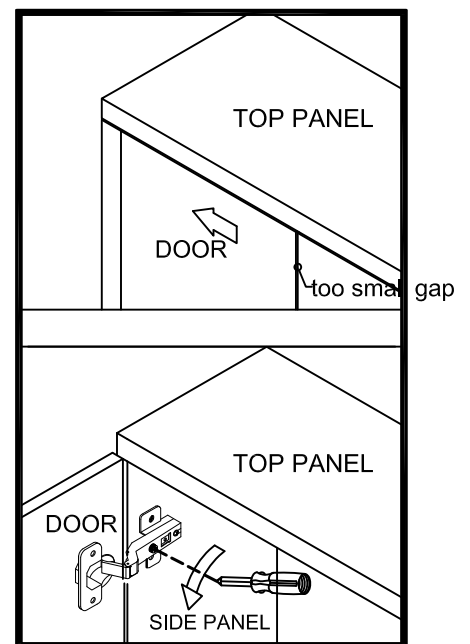

Turn the screw counterclockwise a little as shown to make the gap big.