













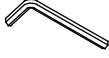







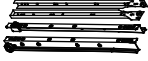

**USER'S MANUAL**

# PRODUCT ASSEMBLY

## Hardware List

A	 6*35mm	63 pcs	I		4 pcs	Q	 6*50mm	8 pcs
B	 15*10mm	63 pcs	J		3 pcs	R		1 pc
C	 8*30mm	52 pcs	K		8 pcs	S	 8*50mm	4 pcs
D	 3*12mm	36 pcs	L	 2.5*12mm	48 pcs	T		2 pcs
E	 3.5*12mm	40 pcs	M		3 sets	U	 4*14mm	2 pcs
F	 4*30mm	12 pcs	N		20 pcs	V		2 pcs
G	 4*40mm	8 pcs	O		8 pcs	W	 3.5*40mm	2 pcs
H	 4*16mm	10 pcs	P		8 pcs			

# PRODUCT ASSEMBLY

Carton 1 of 2 part list: part 1, part 2, part 3, part 4, part 5, part 6, part 7, part 8, part 9, part 10, part 13, part 18, part 19, part 20, part 22, part 26, part 32, part 33, part 34, part 35, part 36, part 37.

Carton 2 of 2 part list: part 11, part 12, part 14, part 15, part 16, part 17, part 21, part 23, part 24, part 25, part 27, part 28, part 29, part 30, part 31.





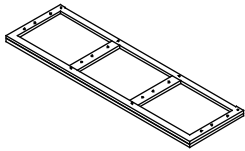
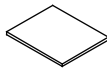
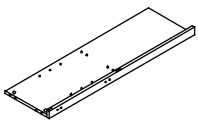
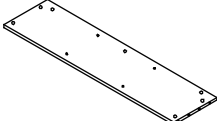
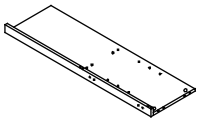
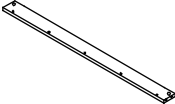
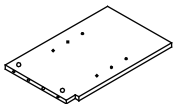
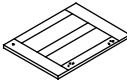
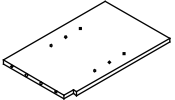
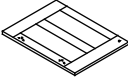
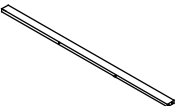
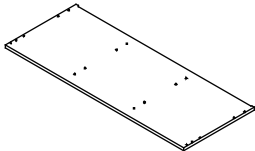
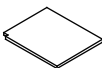
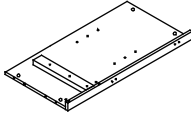





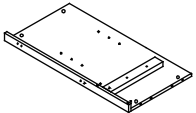

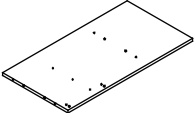

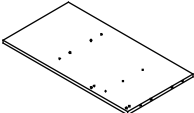
Please note: Hardware box was packed in Carton 1 of 2 (HW64504-12).  
Part 36 and part 37 were packed in the hardware box.

## Parts List

1		1 pc	8		1 pc
2		1 pc	9		1 pc
3		1 pc	10		1 pc
4		1 pc	11		1 pc
5		1 pc	12		1 pc
6		1 pc	13		1 pc
7		2 pcs	14		1 pc

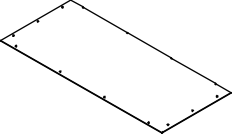
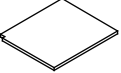
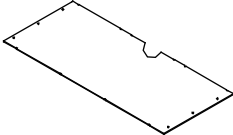
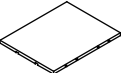
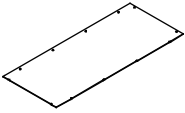
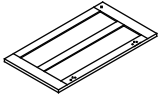
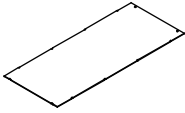
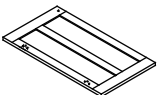
# PRODUCT ASSEMBLY

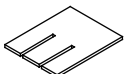
## Parts List

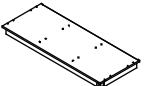
15		1 pc	27		3 pcs
16		1 pc	28		3 pcs
17		1 pc	29		3 pcs
18		2 pcs	30		3 pcs
19		2 pcs	31		3 pcs
20		2 pcs	32		1 pc
21		2 pcs	33		1 pc
22		1 pc	34		2 pcs
23		1 pc	35		1 pc
24		1 pc	36		4 pcs
25		4 pcs	37		1 pc
26		1 pc			

# PRODUCT ASSEMBLY

## Part List Assembly Overview

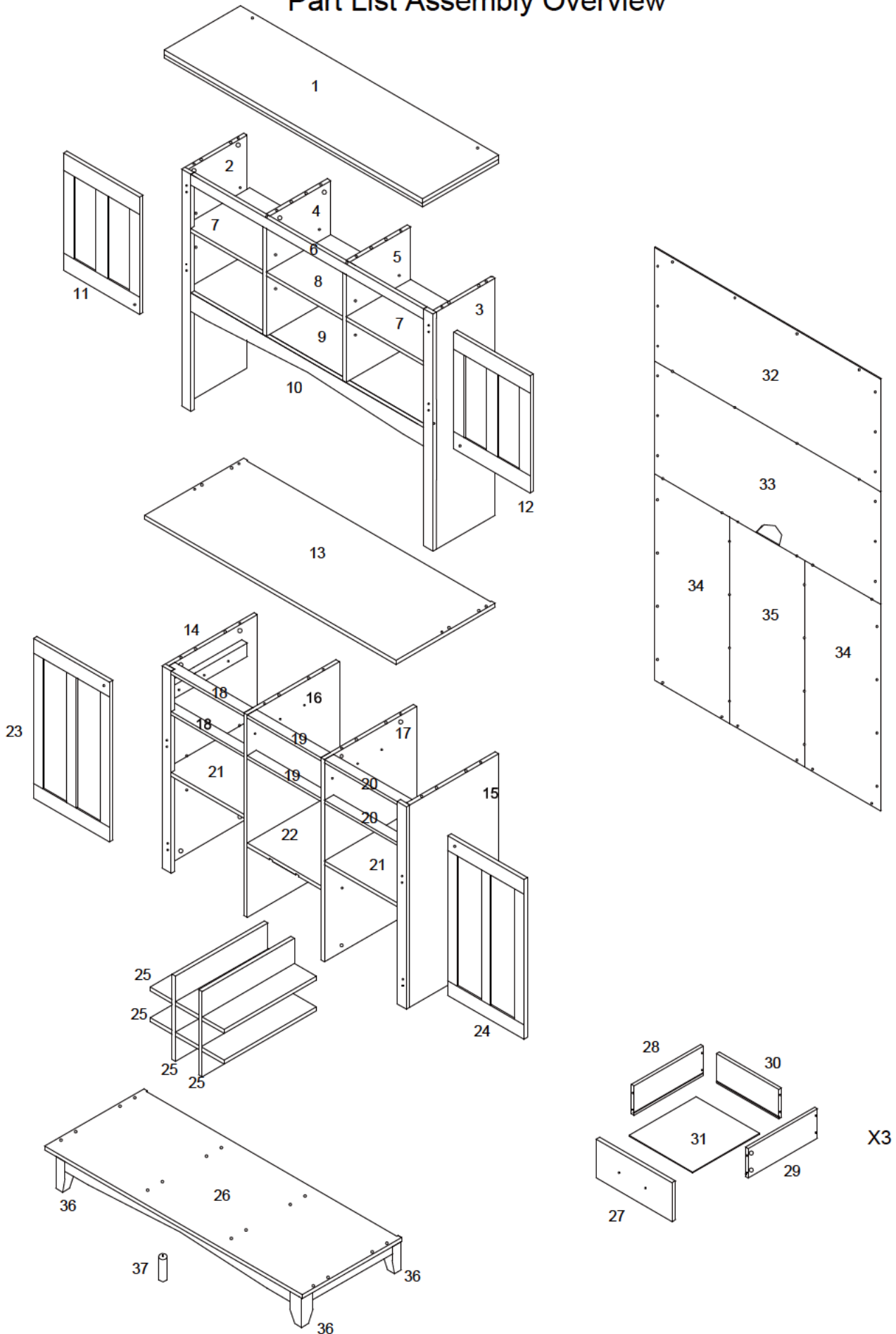

# PRODUCT ASSEMBLY

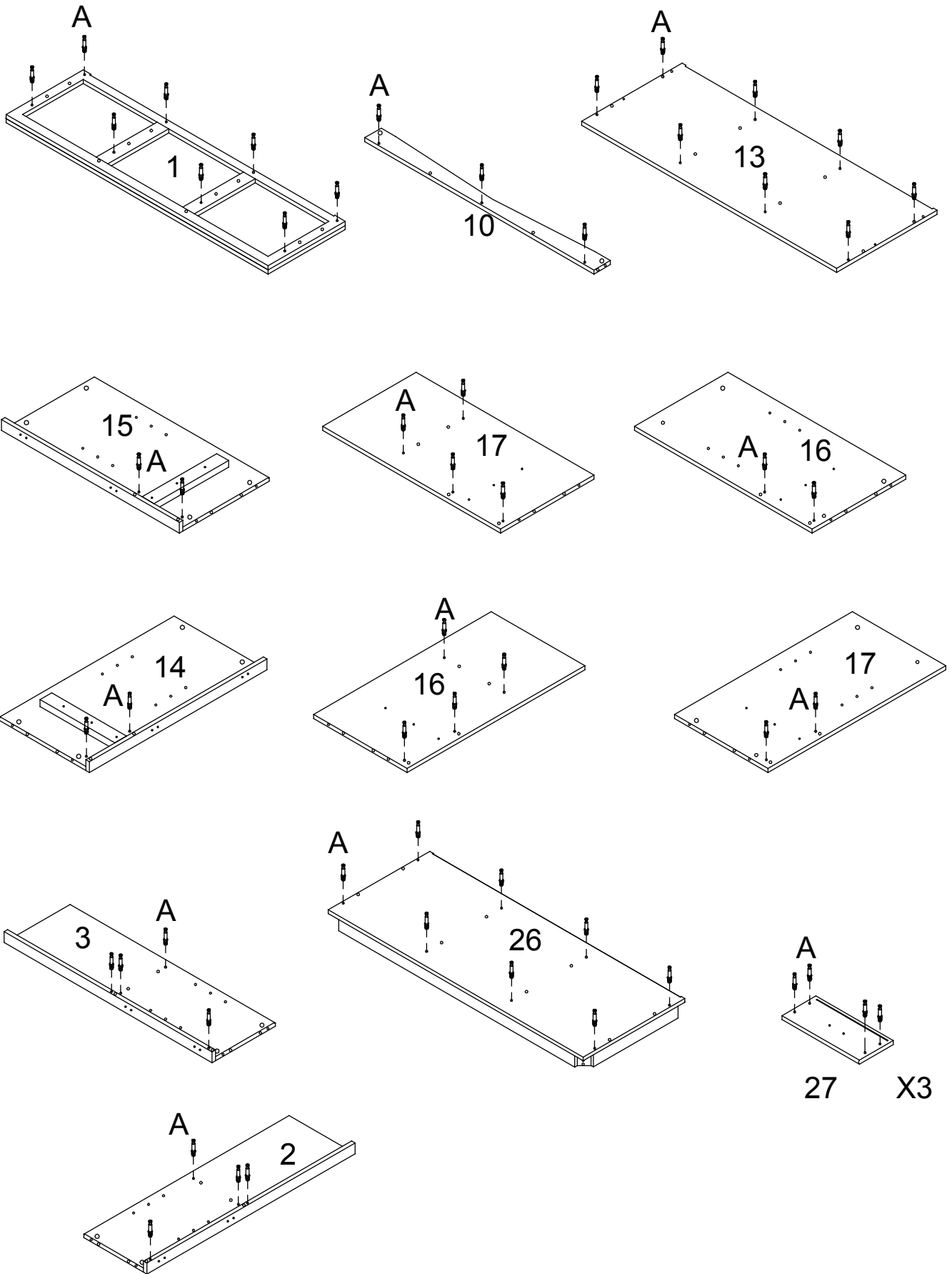

A  63 pcs

## Step 1



# PRODUCT ASSEMBLY

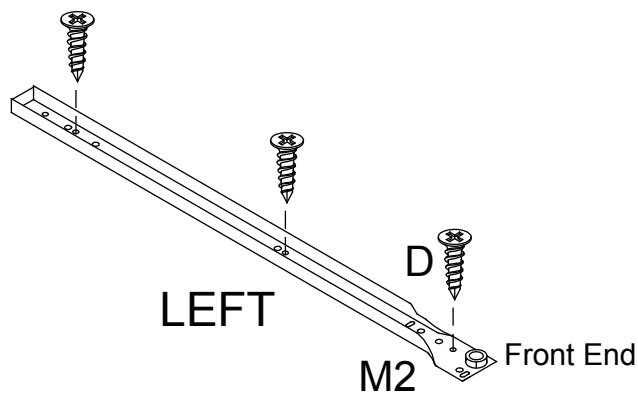
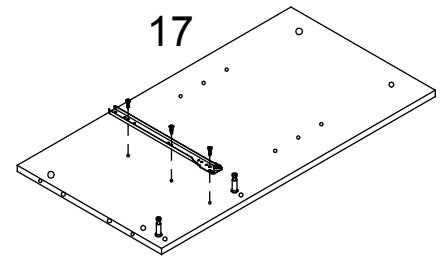
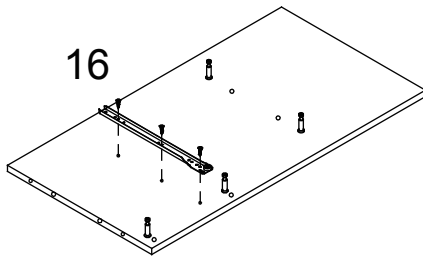
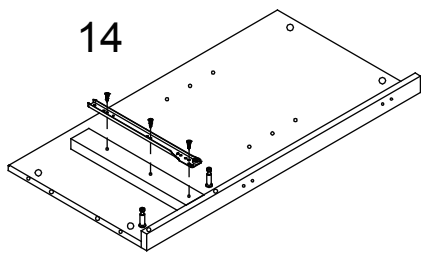
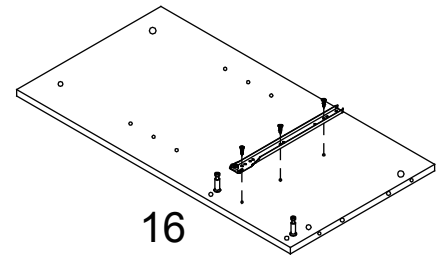
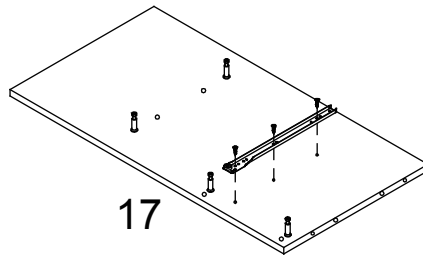
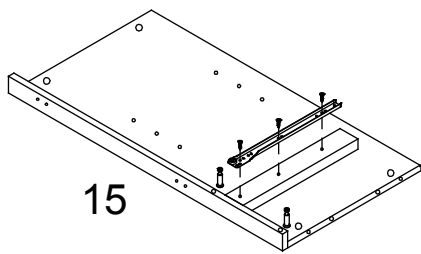
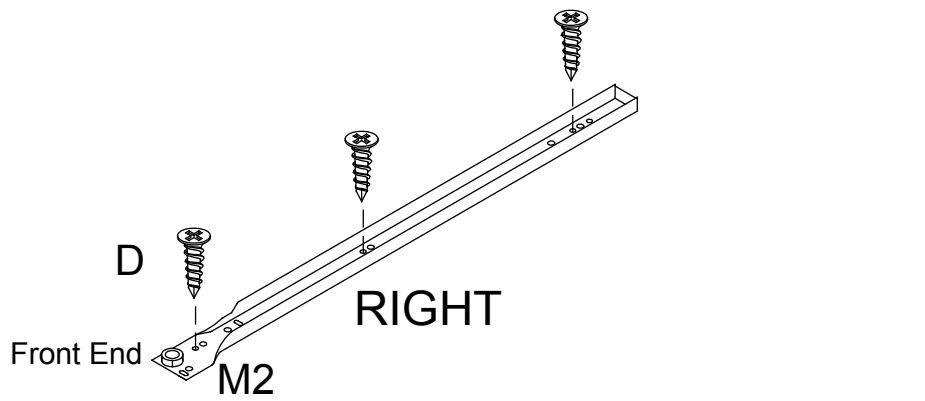

## Step 2

D		18 pcs
M2		3 sets



# PRODUCT ASSEMBLY

## Step 3

E		24 pcs
K		8 pcs

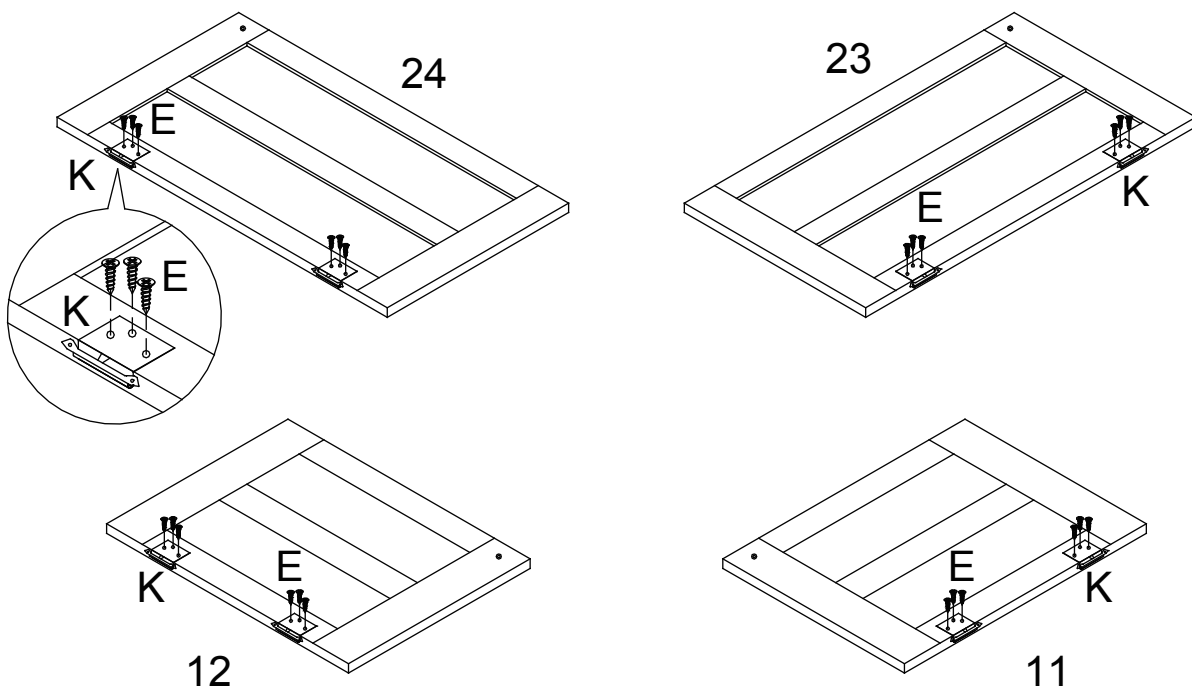

## Step 4

H		4 pcs
I		4 pcs

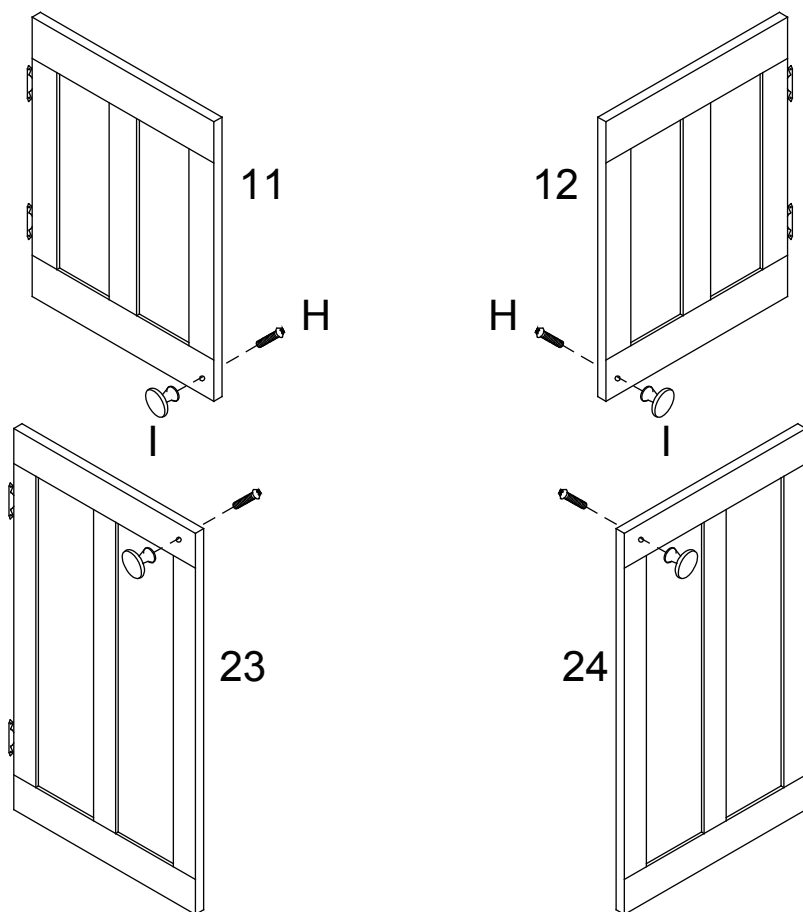

# PRODUCT ASSEMBLY

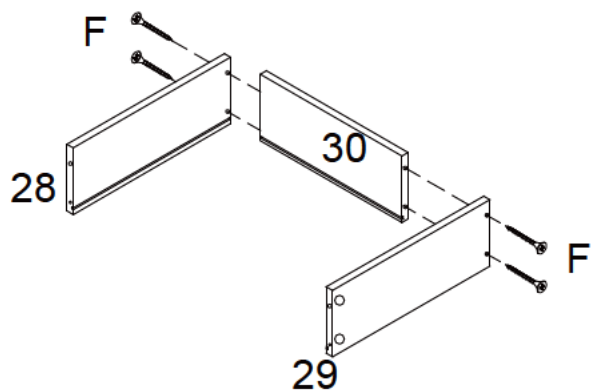

Step 5

F		12 pcs
---	---	--------



X3

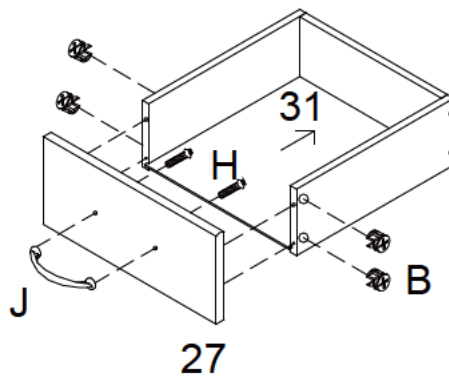

Step 6

B		12 pcs
H		6 pcs
J		3 pcs



X3

Step 7

D		18 pcs
M1		3 sets

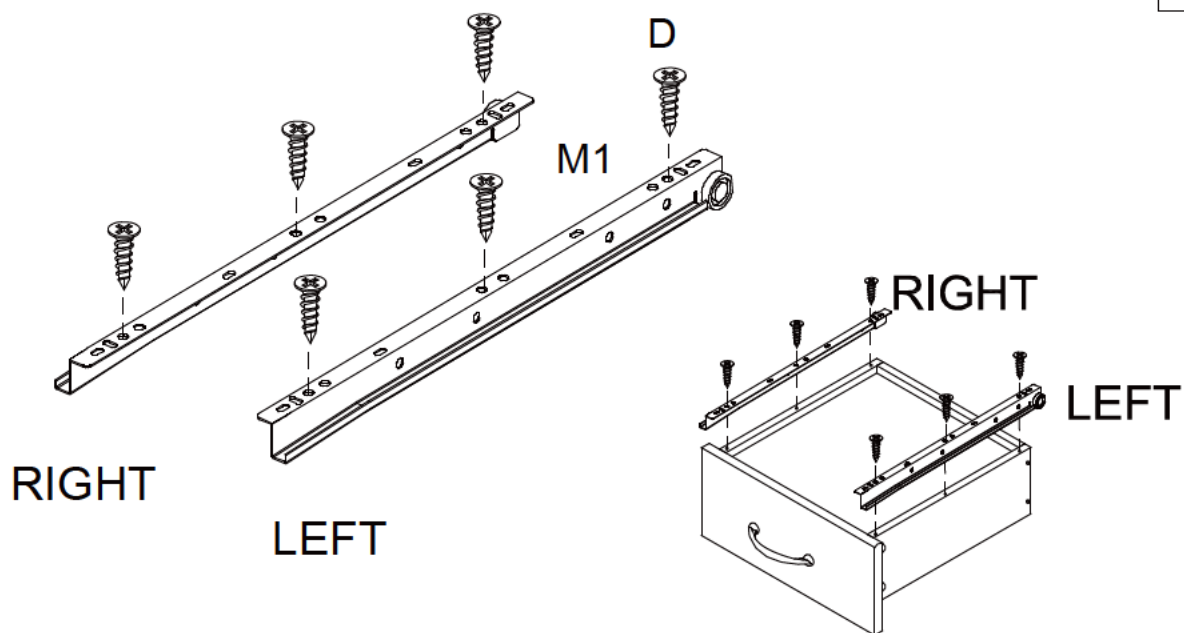

X3

# PRODUCT ASSEMBLY

## Step 8

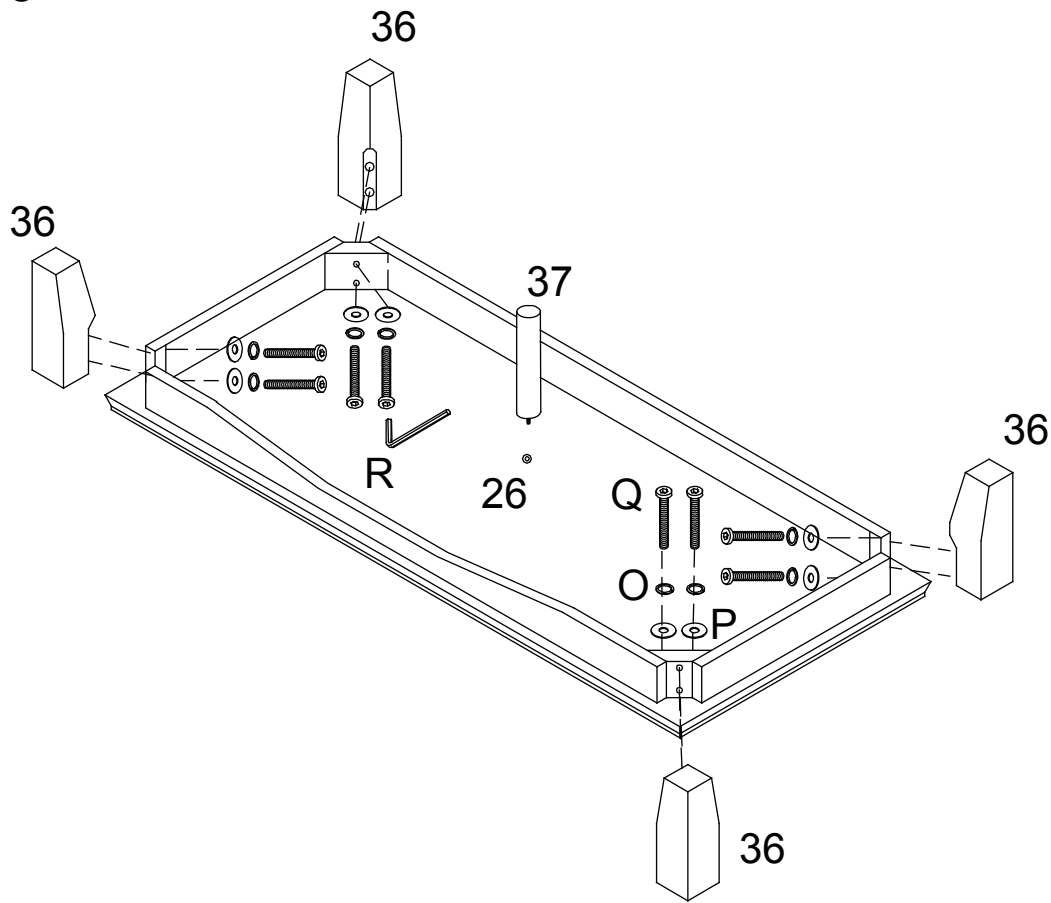

O		8 pcs
P		8 pcs
Q		8 pcs
R		1 pc

## Step 9

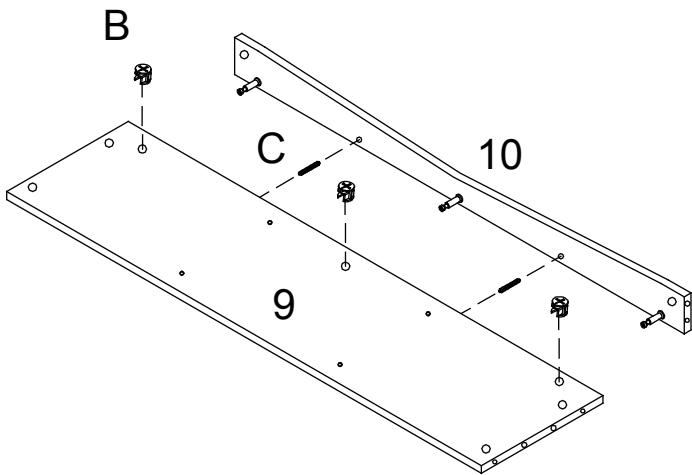

B		3 pcs
C		2 pcs

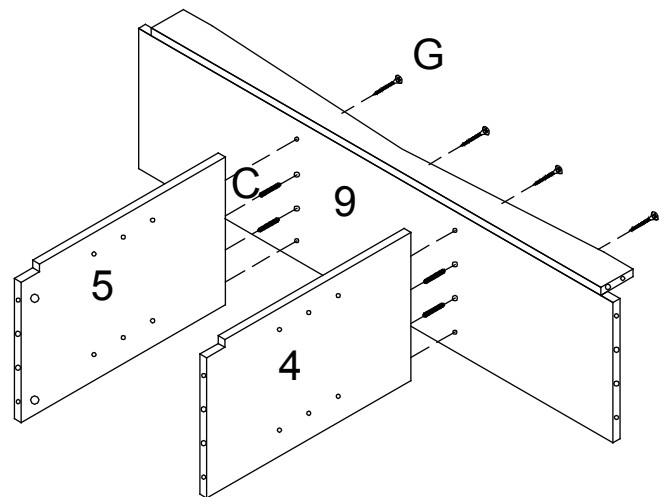

## Step 10



C		4 pcs
G		4 pcs



# PRODUCT ASSEMBLY

## Step 11

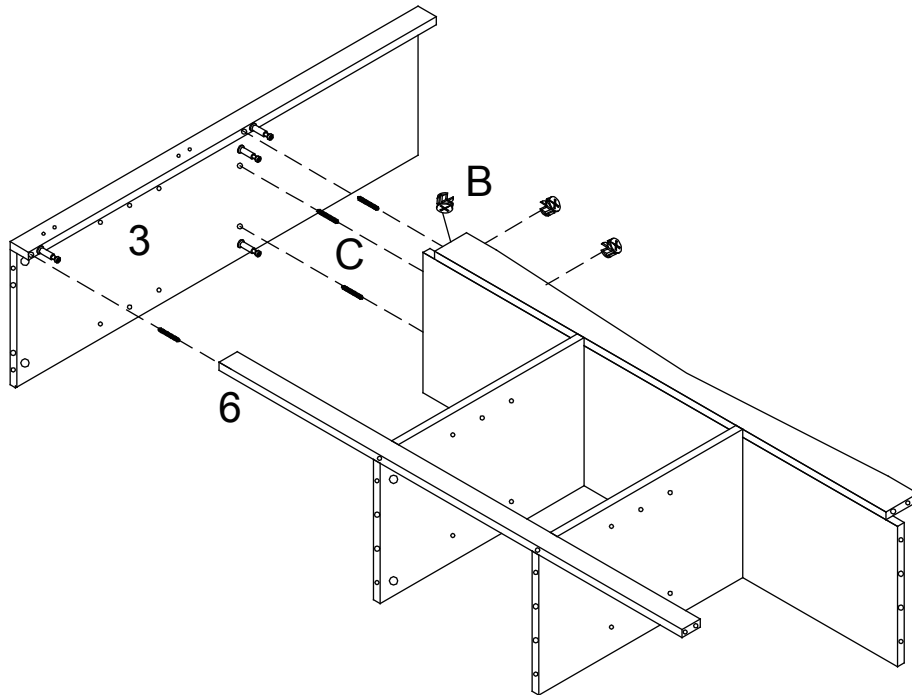
B		3 pcs
C		4 pcs



## Step 12

B		5 pcs
C		4 pcs

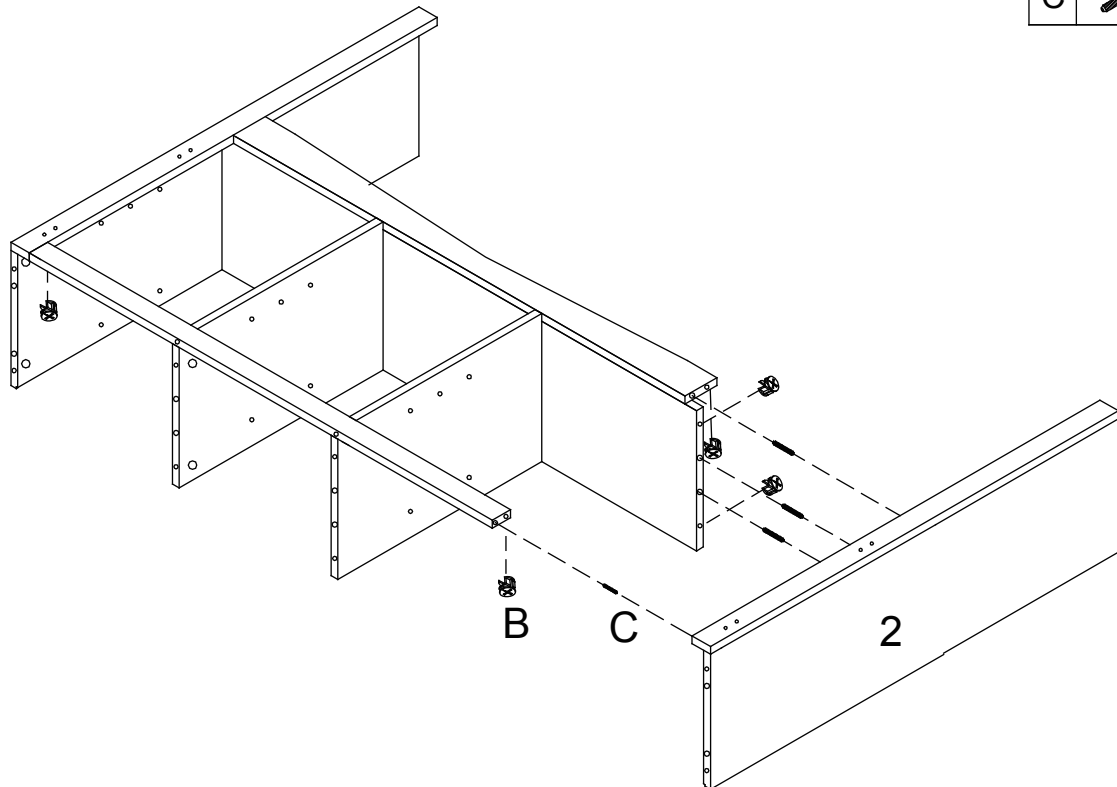

# PRODUCT ASSEMBLY

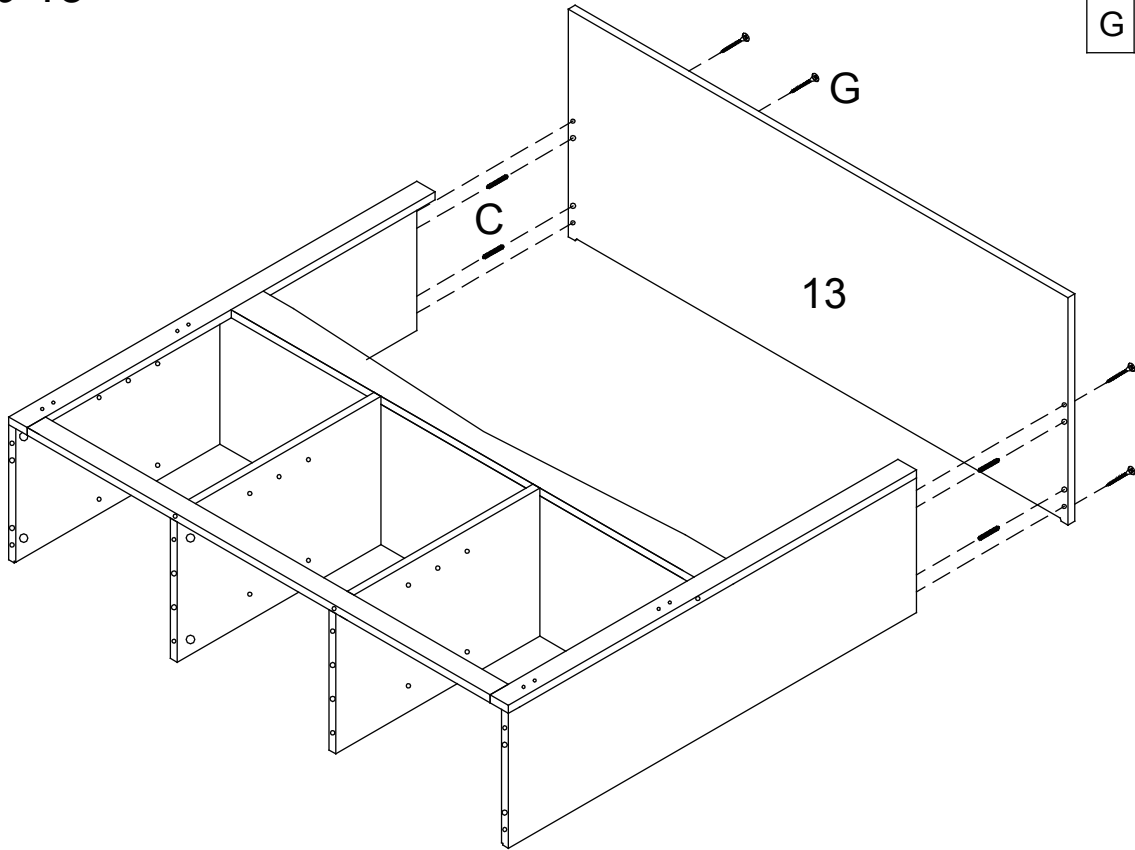

## Step 13

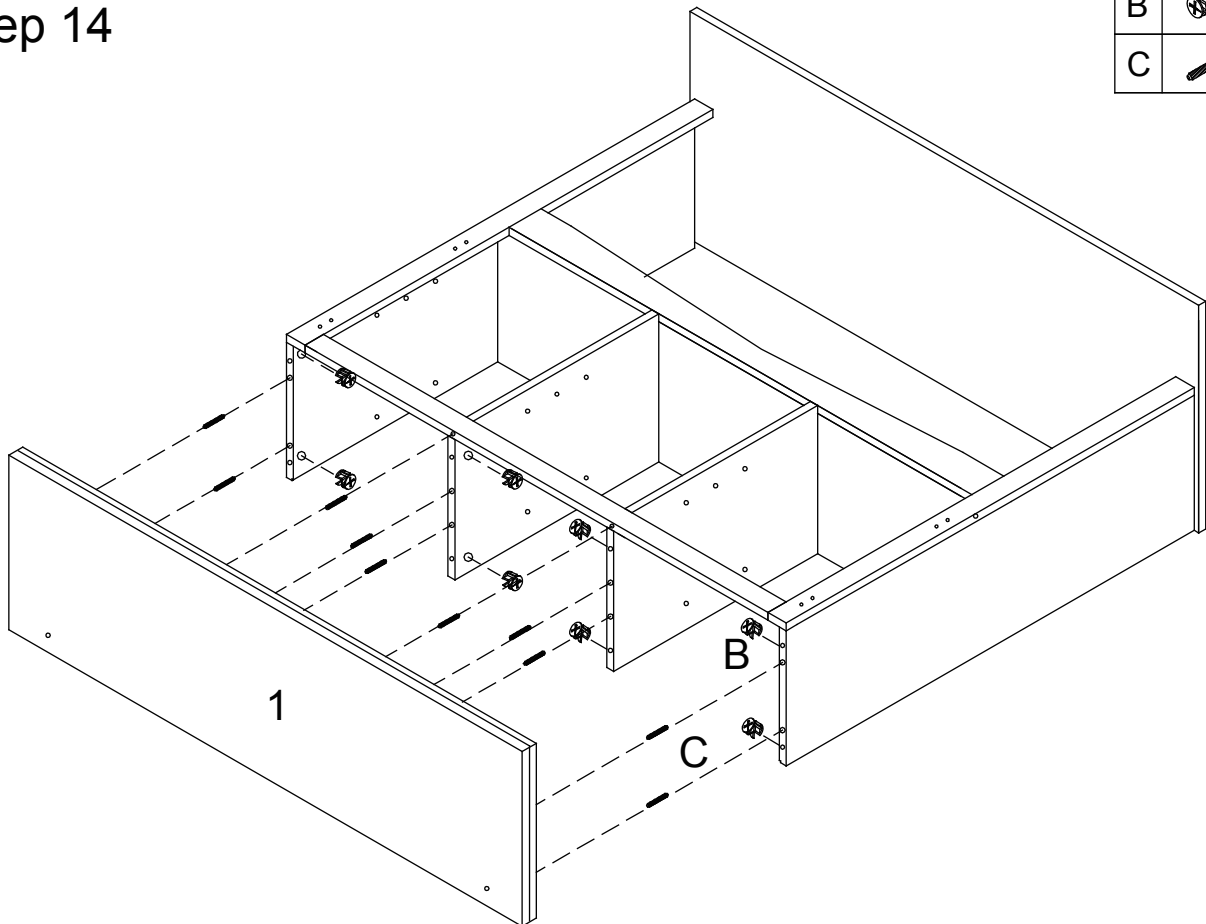

C		4 pcs
G		4 pcs

## Step 14



B		8 pcs
C		10 pcs



# PRODUCT ASSEMBLY

## Step 15

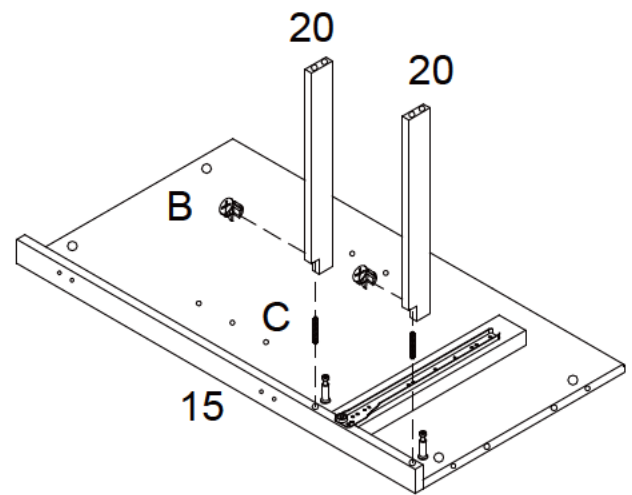
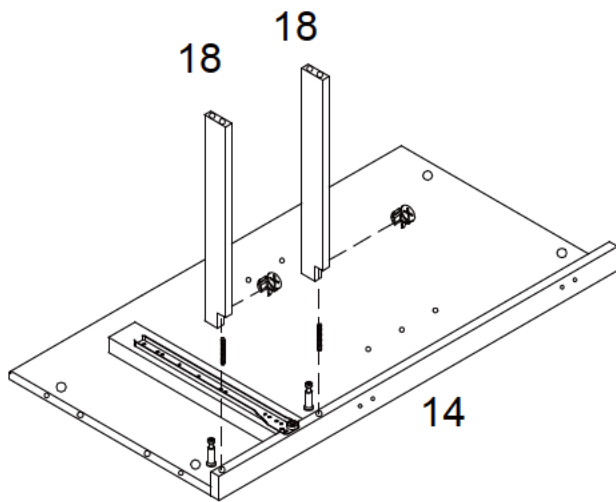
B		4 pcs
C		4 pcs



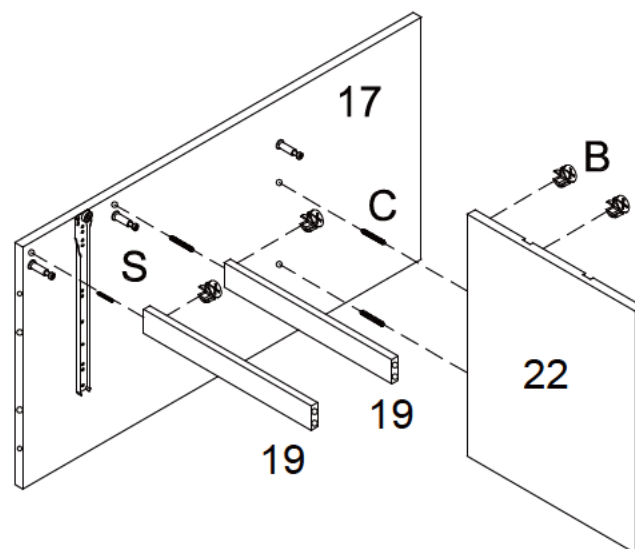

## Step 16

B		4 pcs
C		2 pcs
S		2 pcs



# PRODUCT ASSEMBLY

## Step 17

B		4 pcs
C		2 pcs
S		2 pcs

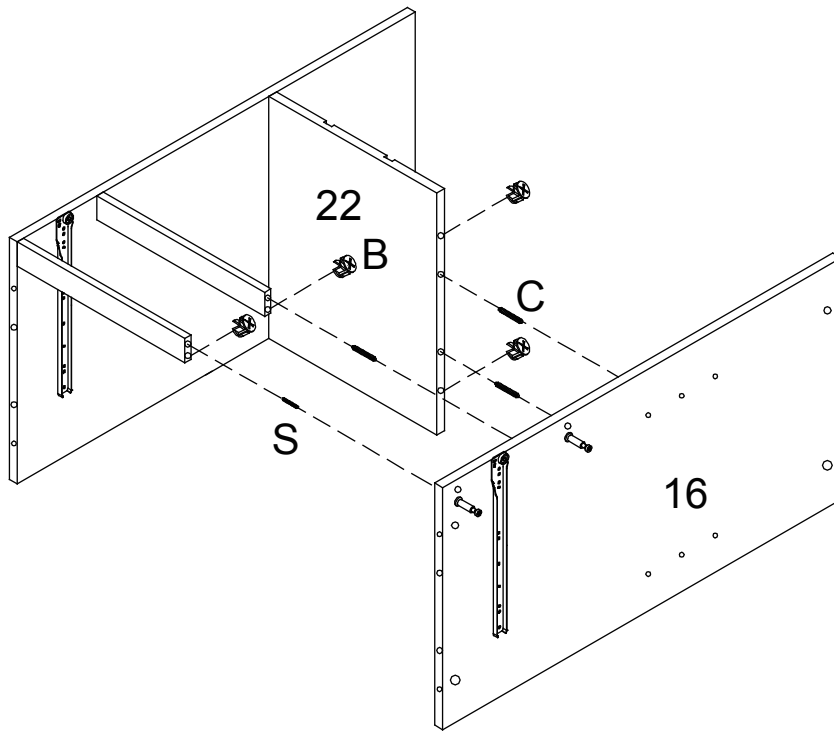

## Step 18

B		2 pcs
---	---	-------

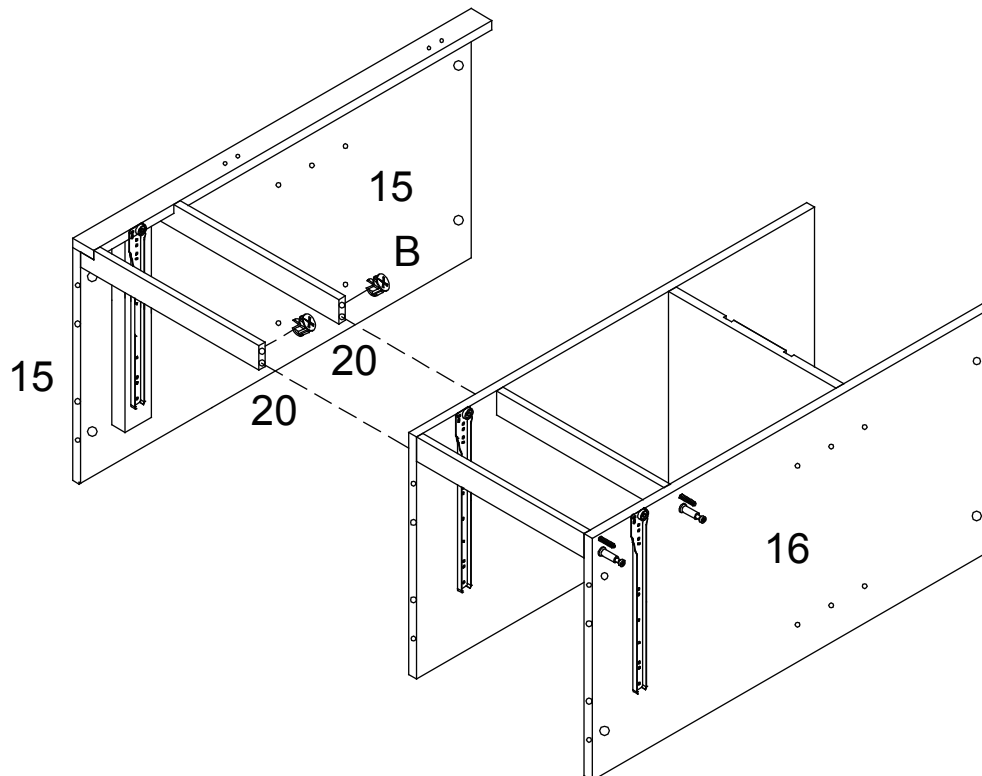



# PRODUCT ASSEMBLY

## Step 19

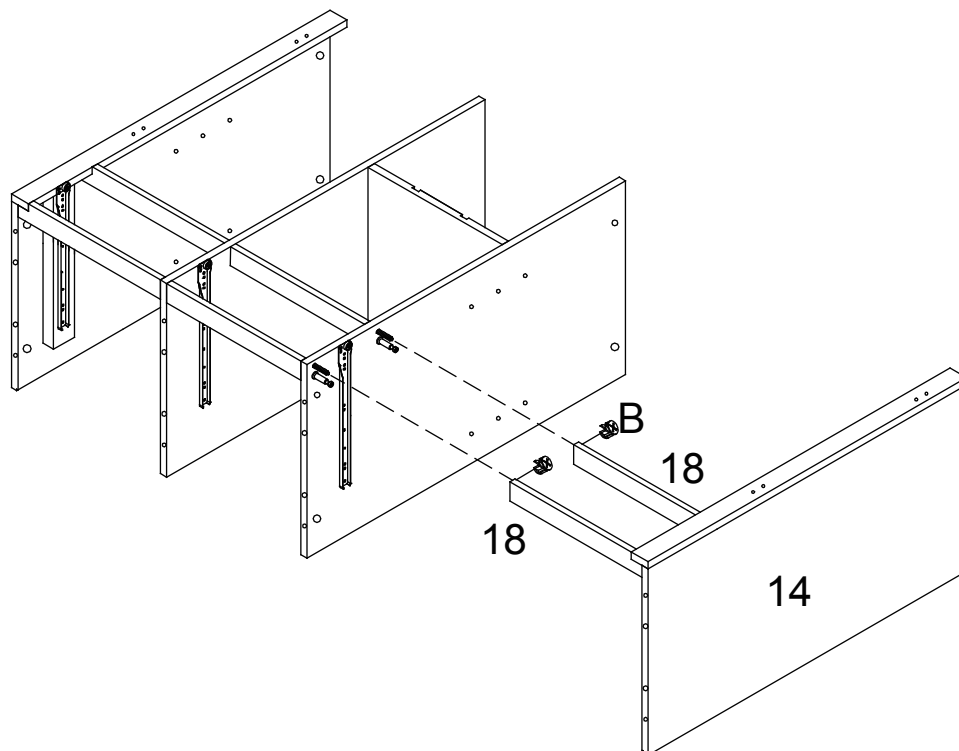
B		2 pcs
---	---	-------



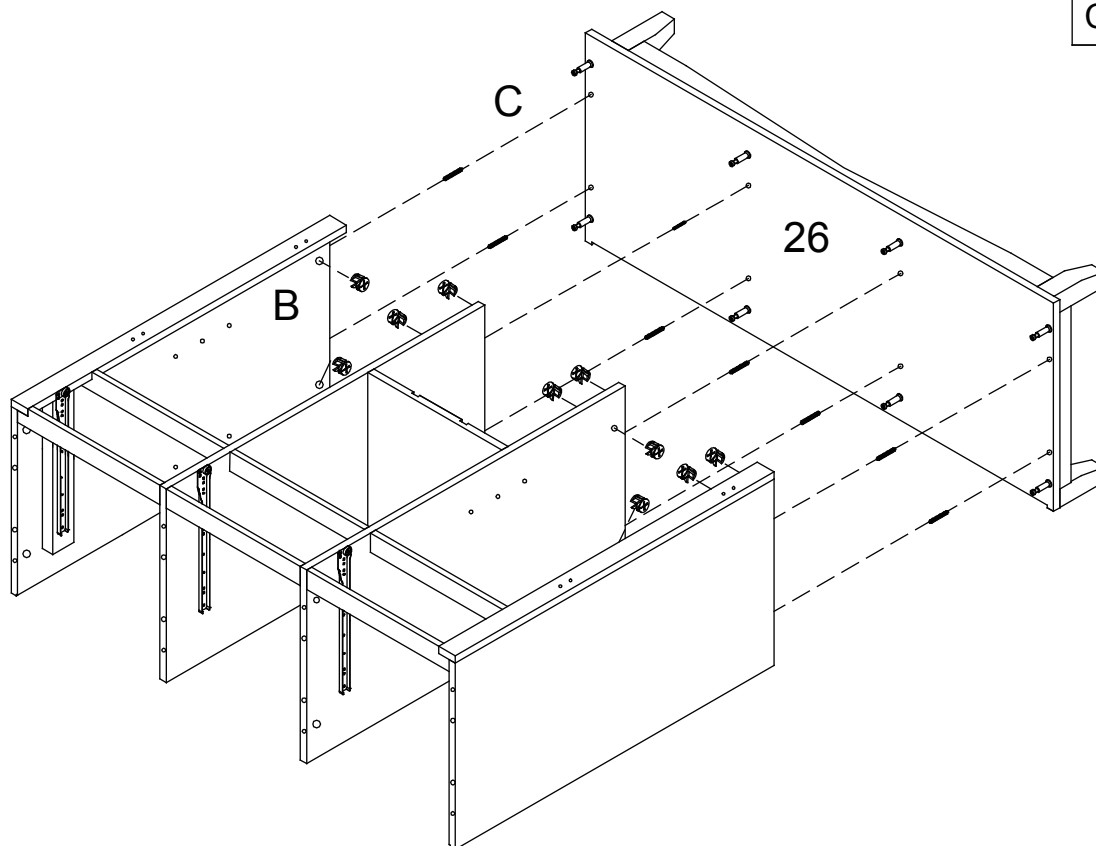

## Step 20

B		8 pcs
C		8 pcs



# PRODUCT ASSEMBLY

## Step 21

B		8 pcs
C		8 pcs

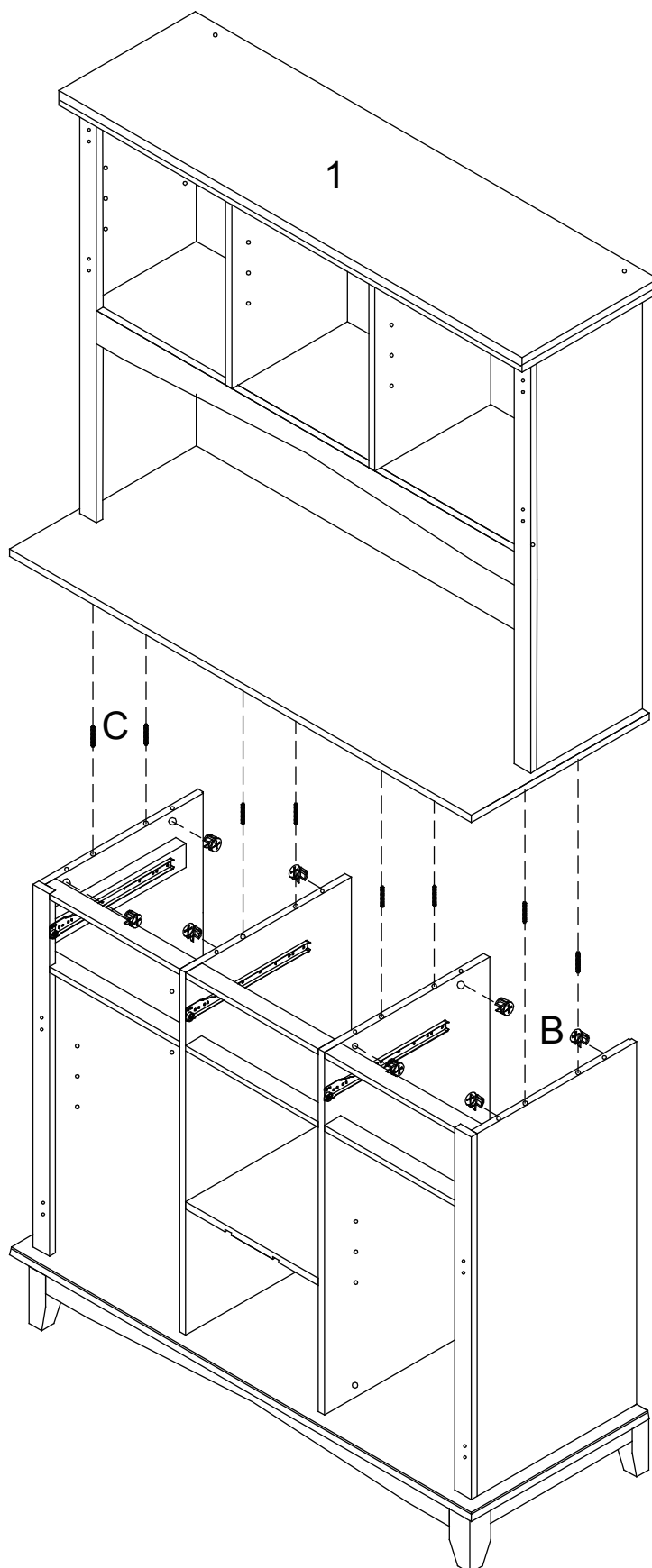

Step 22

L		48 pcs
---	---	--------

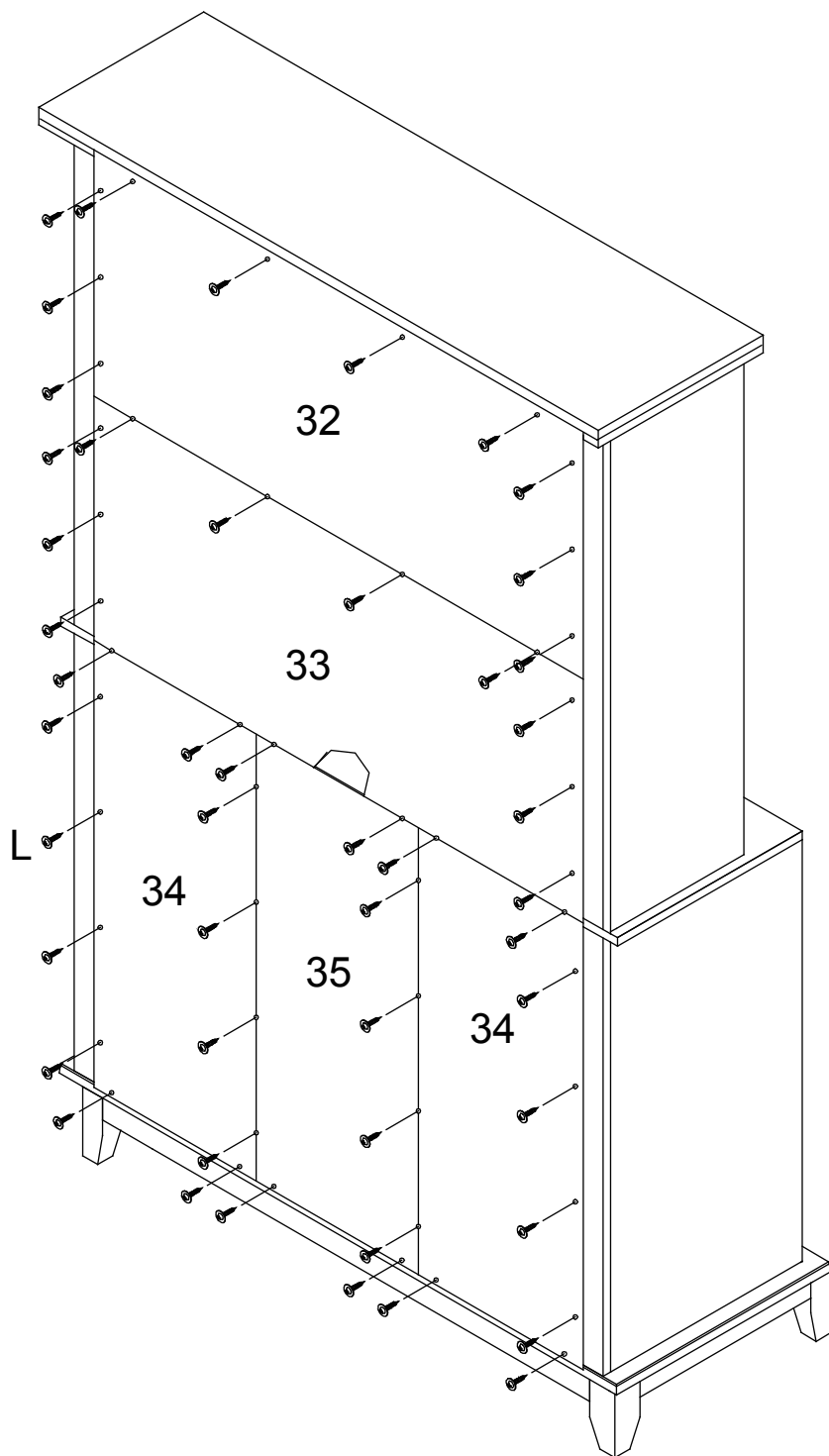

# PRODUCT ASSEMBLY

Step 23

N		20 pcs
---	---	--------

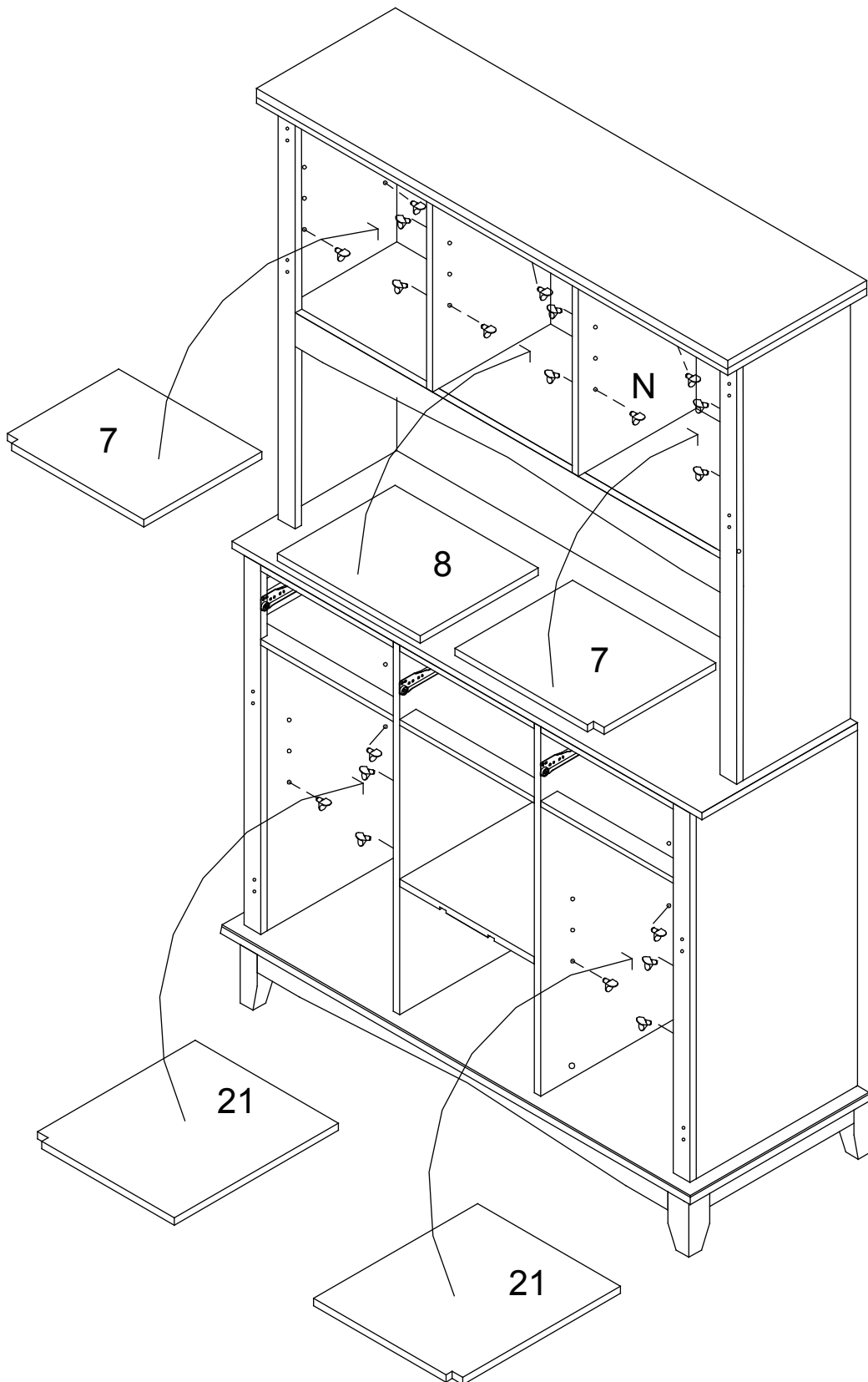

# PRODUCT ASSEMBLY

## Step 24

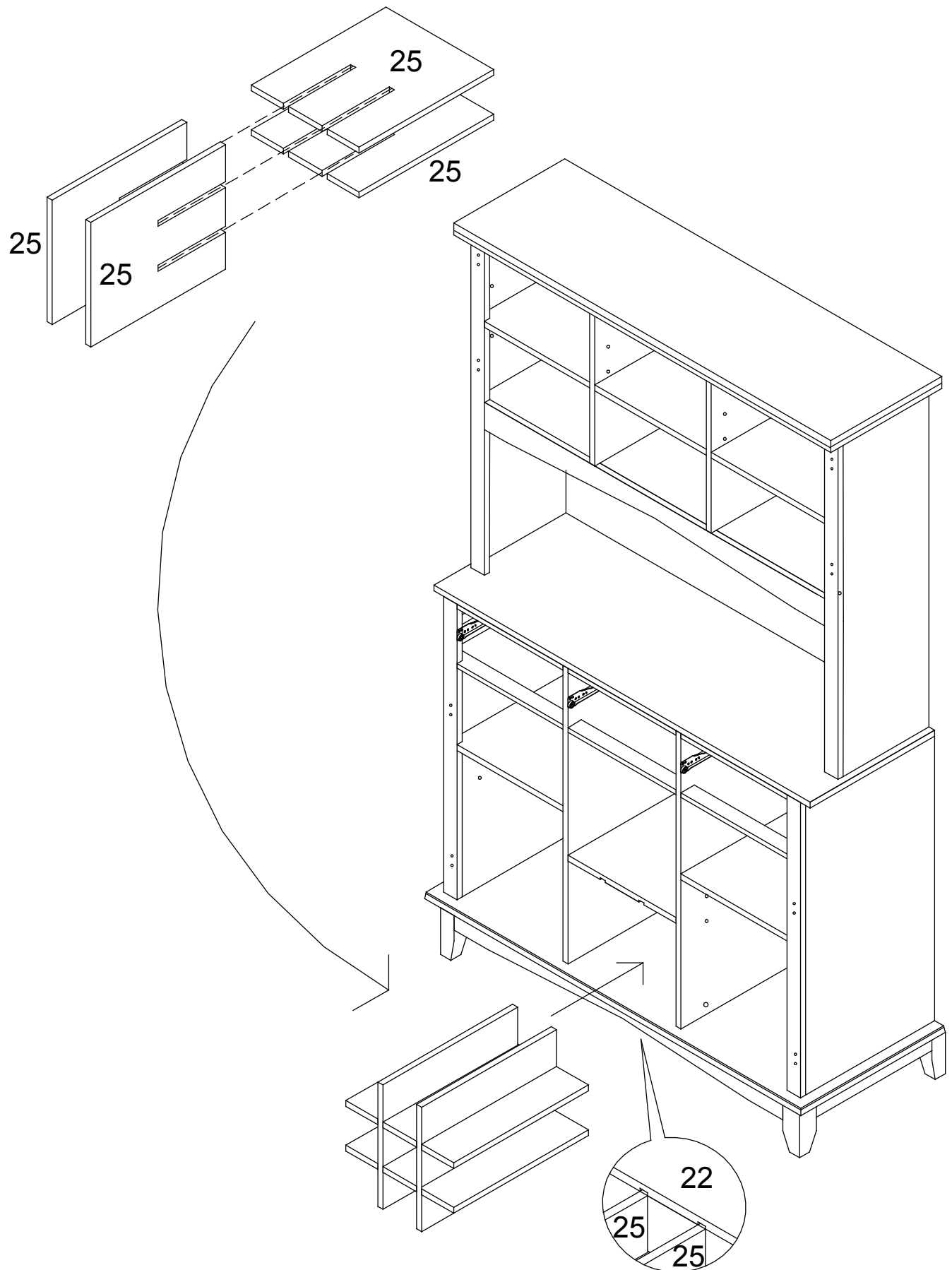

# PRODUCT ASSEMBLY

## Step 25

E



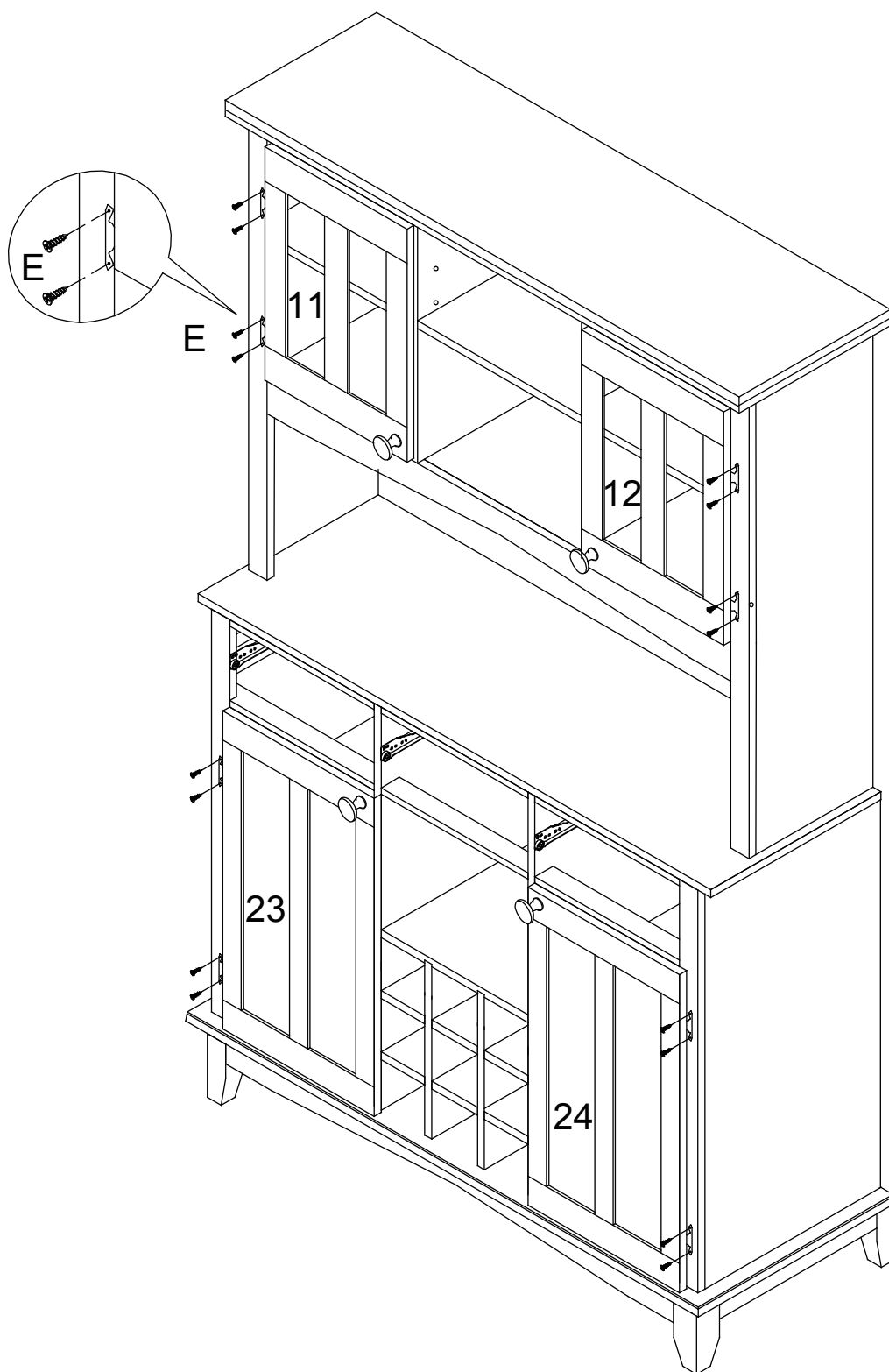

16 pcs



# PRODUCT ASSEMBLY

## Step 26

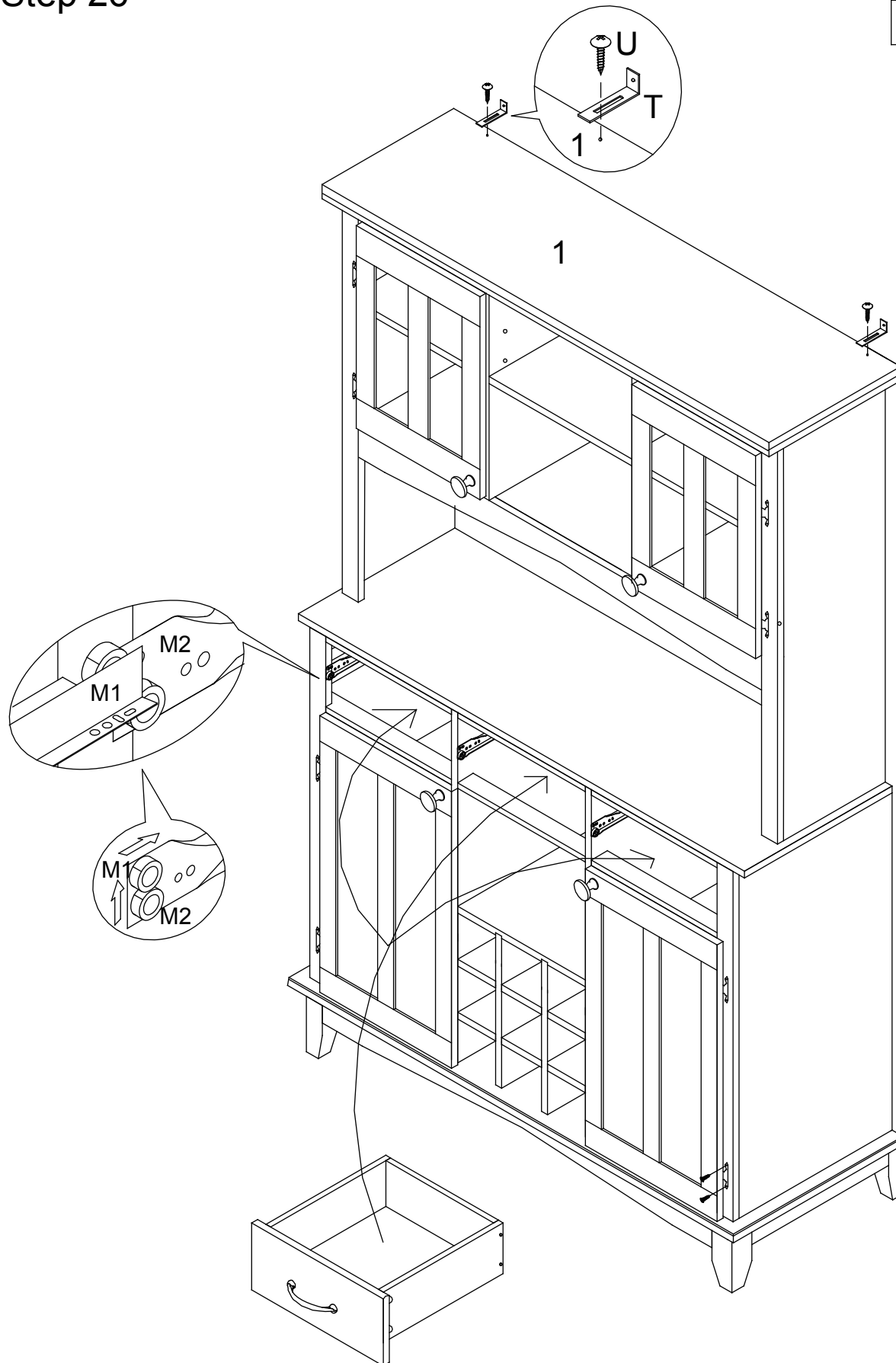

T		2 pcs
U		2 pcs



# PRODUCT ASSEMBLY

## Step 27

Bracket (T) is adjustable when you rescrew the screw (U).

V		2 pcs
W		2 pcs

