

Assembly Instructions

Instructions de montage

Instrucciones de armado

Hanging storage cabinet

2 Person Assembly Recommended

Il est recommandé de monter ce produit à 2 personnes

Dos personas son recomendadas para el ensamblaje del producto

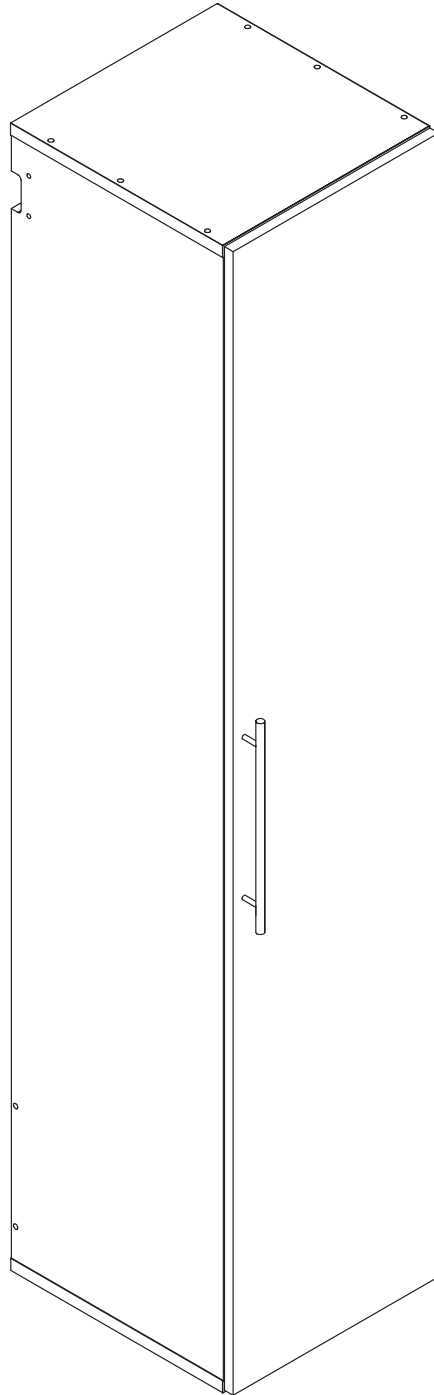

NEED ASSISTANCE CONTACT US FIRST!

Replacement parts will leave our facility within two business days via UPS ground or mail. Please note: shipping times will vary depending on location.

Before you call please:

- 1) Record the following information from the shipping label on the outside of the box. You will need it for warranty purposes:
 - Ship To Name
 - Sales Order Number
- 2) Note the product model number.
- 3) Review the contents of your shipment to determine what you are missing.

Option de service en ligne

- Si vous avez reçu une pièce endommagée ou défectueuse
- Si vous manquez la quincaillerie ou les pièces

Complétez le formulaire Commande de Pièces de Rechange disponible dans la section Soutien à la clientèle de notre

Les pièces de rechange quitteront notre installation dans deux jours ouvrables via UPS par terre ou le courrier. Notez s'il vous plaît que les temps d'expédition varieront selon l'emplacement.

Pour parler avec quelqu'un en français, s'il vous plaît contacter votre détaillant.

Opción de servicio en línea

- Si usted ha recibido una parte dañada o defectuosa, o
- Si falta alguna parte o componente

Complete la forma para solicitud de piezas de remplazo en la sección de soporte al cliente en nuestra página

Para solicitar ayuda en español por favor contacte su distribuidor.

Las piezas de recambio dejarán nuestras instalaciones dentro de dos días hábiles vía UPS correo terrestre. Por favor note que el tiempo de transporte variara según la ubicación.

Optional Tools:

Using a power screwdriver will speed up assembly.

CAUTION

Do not over tighten any screw. The last few turns of each screw should be done very slowly or by hand.

Outils facultatifs:

Utilisant la puissance un tournevis accélérera l'assemblée.

ATTENTION

Évitez de trop serrer les vis. Ralentissez la vitesse de la foreuse pour les derniers deux tours de vis ou vissez-les lentement à la main.

Herramientas opcionales:

El montaje será más rápido con un destornillador eléctrico.

PRECSUCION

No apriete los tornillos demasiado. Las últimas vueltas de cada tornillo deben hacerse muy lentamente o con la mano.



Part numbers are for reference only.
Product parts are not labeled.

Les numéros de pièce sont à titre de référence seulement.
Les pièces du produit ne sont pas étiquetées.

Los números de pieza son sólo de referencia.
Las piezas del producto no están etiquetadas.

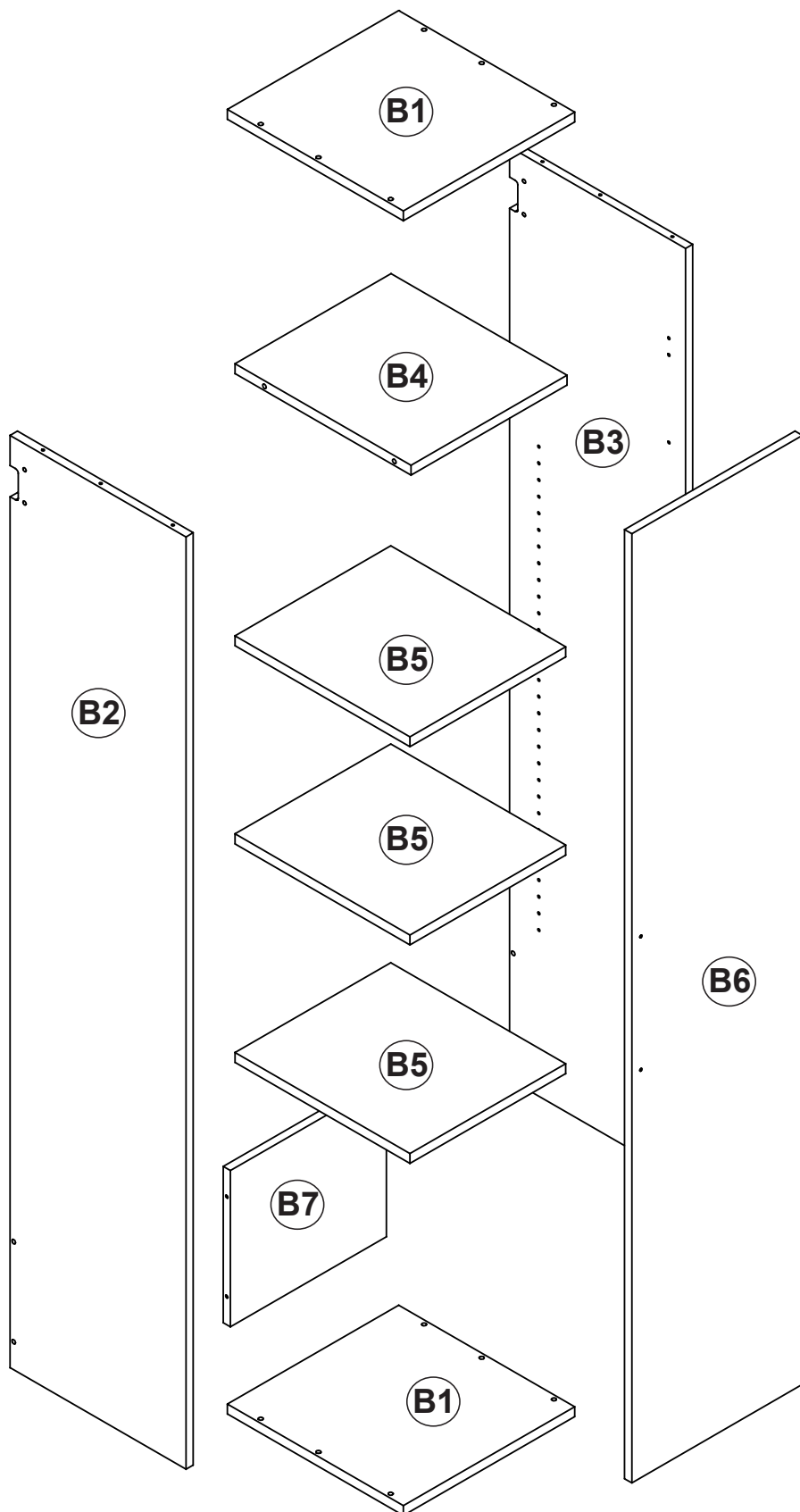

x2 **(B1)** TP-10185-B black
TP-10185-W white
TP-10185-G grey

x1 **(B2)** SL-10053-B black
SL-10053-W white
SL-10053-G grey

x1 **(B3)** SR-10053-B black
SR-10053-W white
SR-10053-G grey

x1 **(B4)** SF-10061-B black
SF-10061-W white
SF-10061-G grey

x3 **(B5)** SH-10133-B black
SH-10133-W white
SH-10133-G grey

x1 **(B6)** DR-10034-B black
DR-10034-W white
DR-10034-G grey

x1 **(B7)** ST-10167-B black
ST-10167-W white
ST-10167-G grey

Required Tools
 Outils requis
 Herramientas necesarias

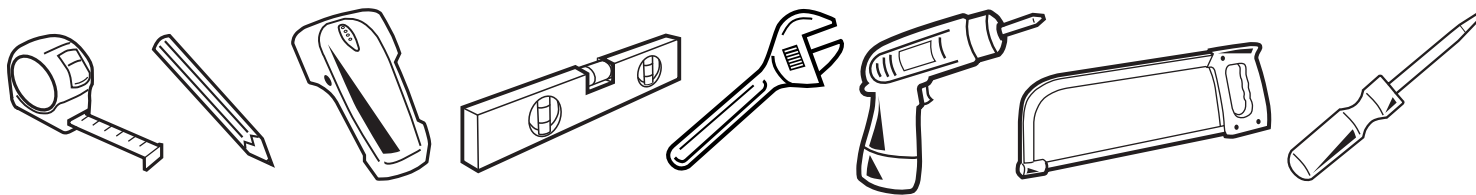

Hardware / Quincaillerie / Piezas de Conexión

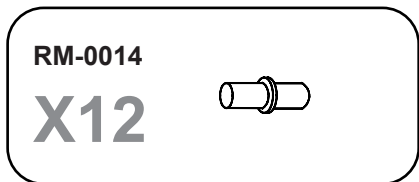
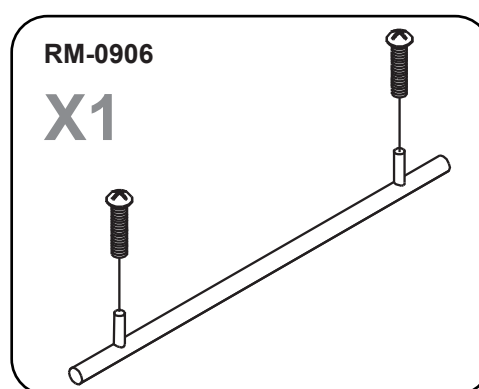
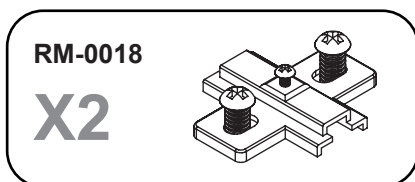
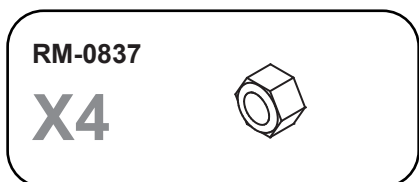
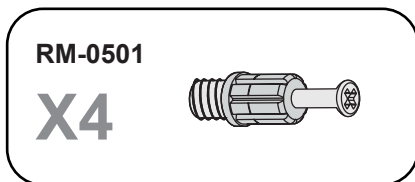
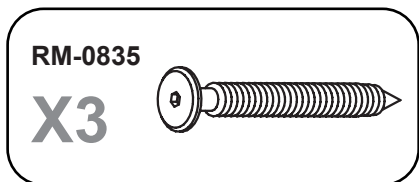
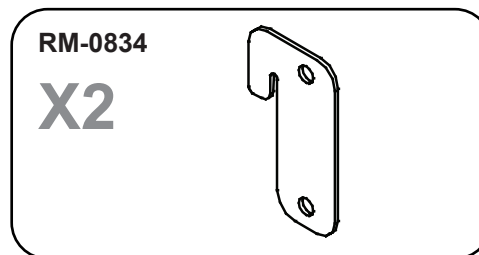
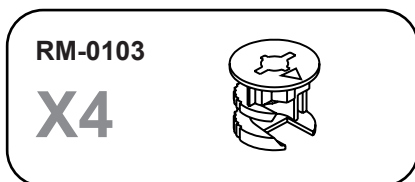
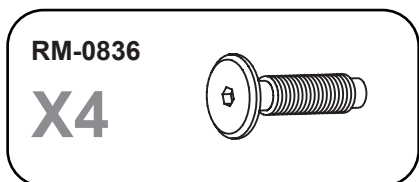
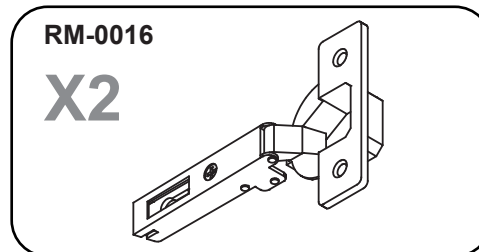
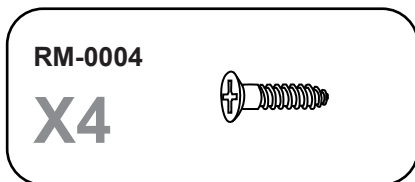
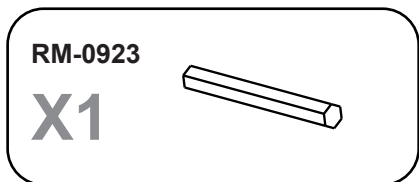
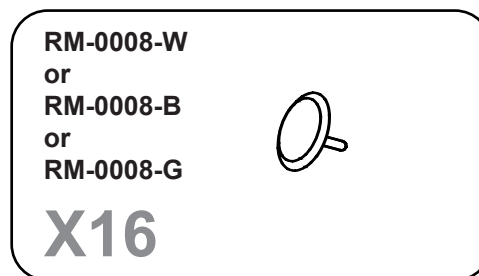
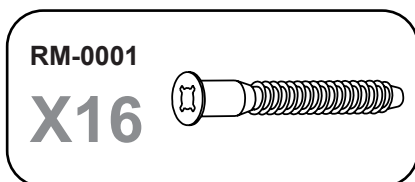
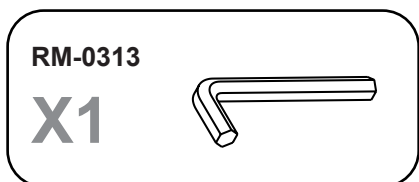
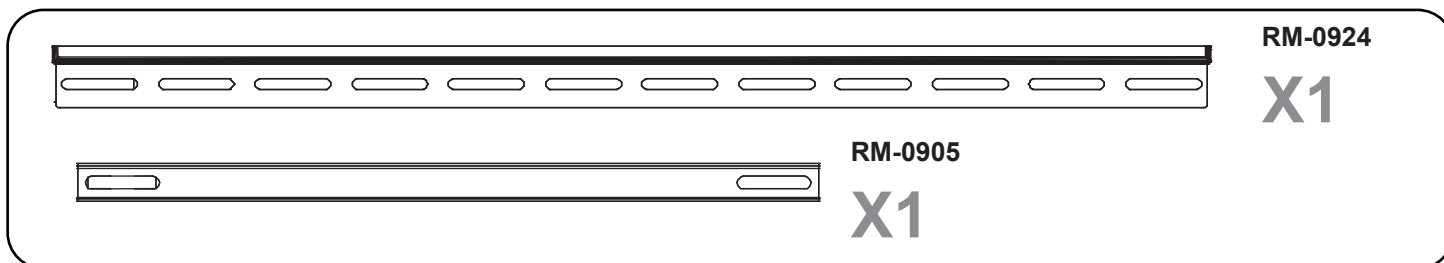

1

RM-0313
X1



RM-0836
X4

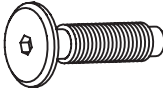

RM-0837
X4



RM-0834
X2

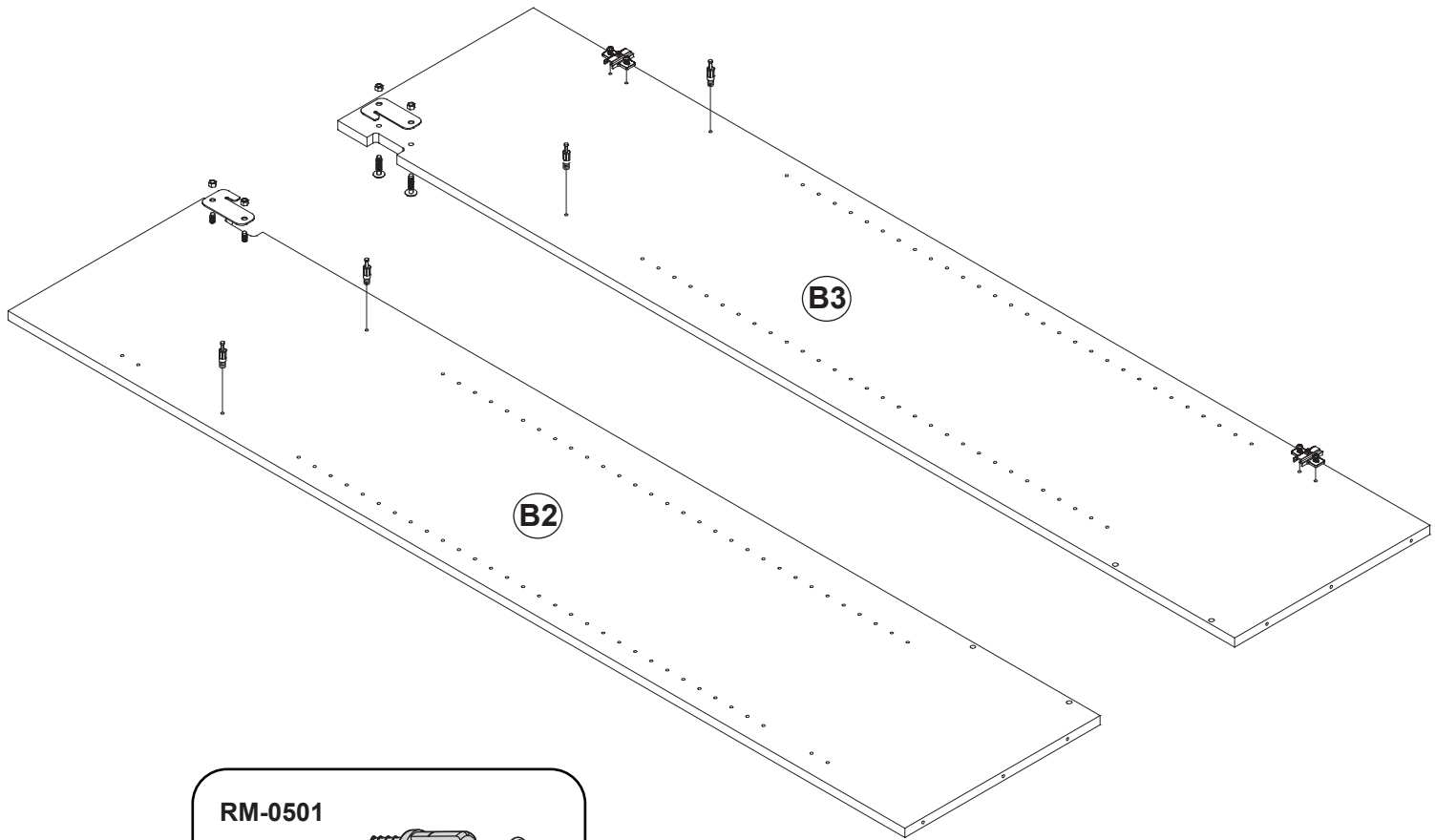
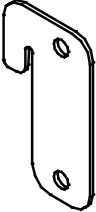

RM-0501
X4

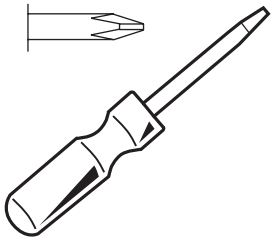
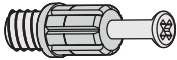

RM-0018
X2

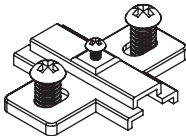

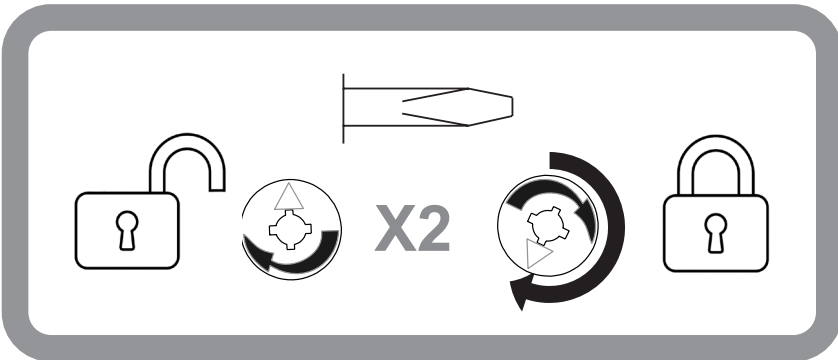
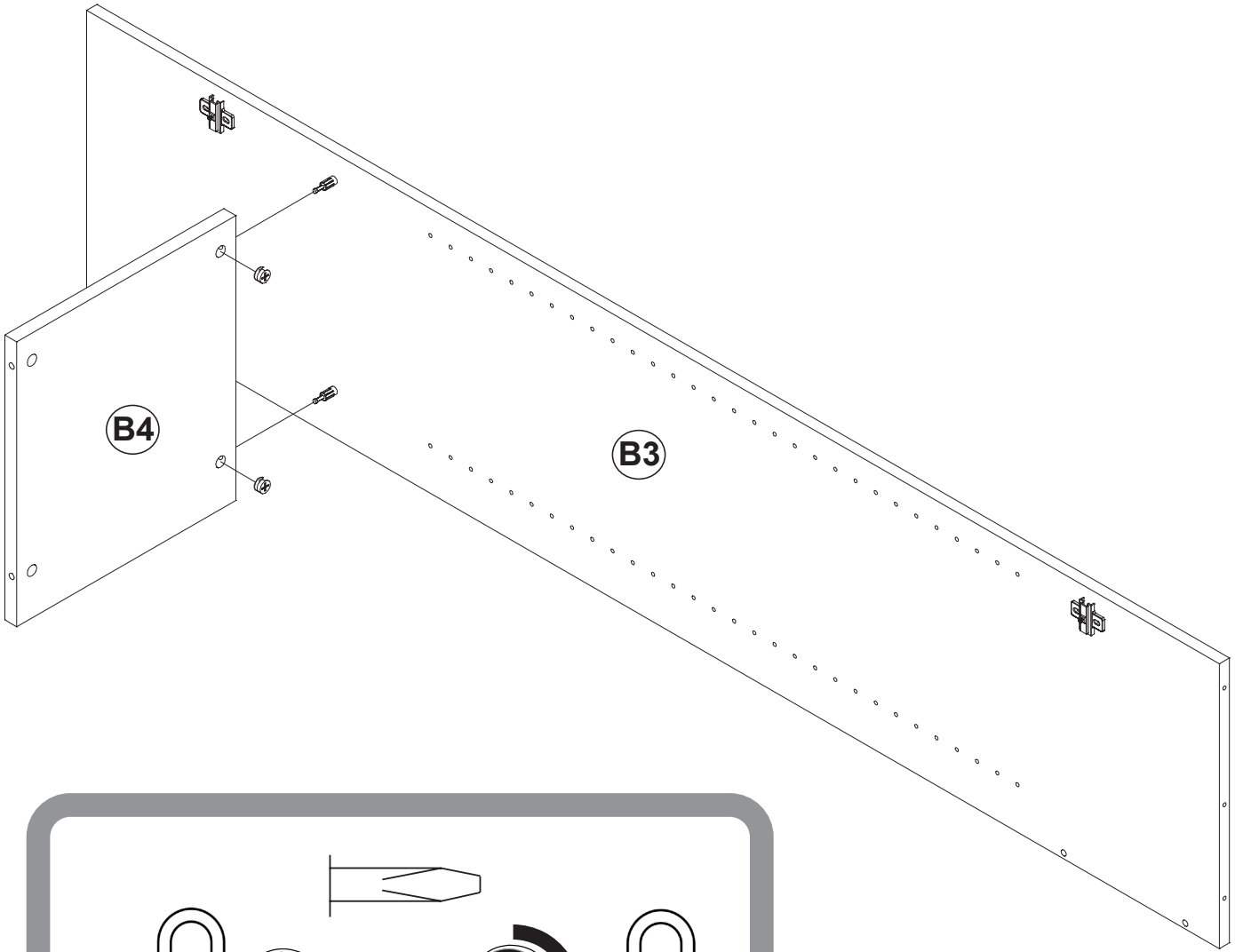
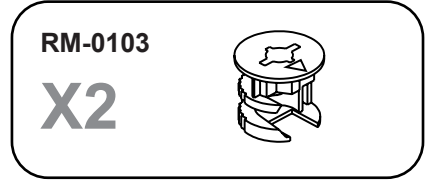
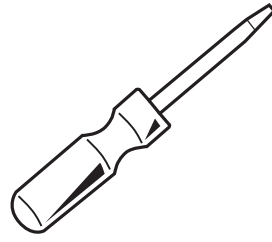
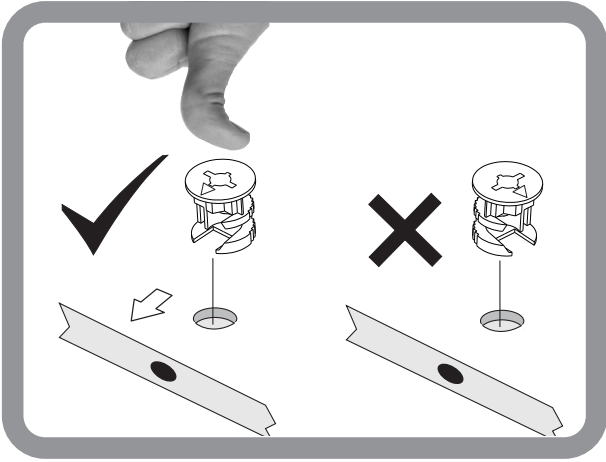

3

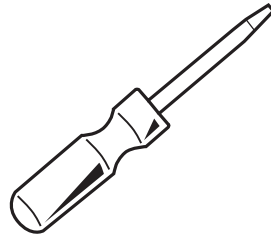

RM-0103
X2

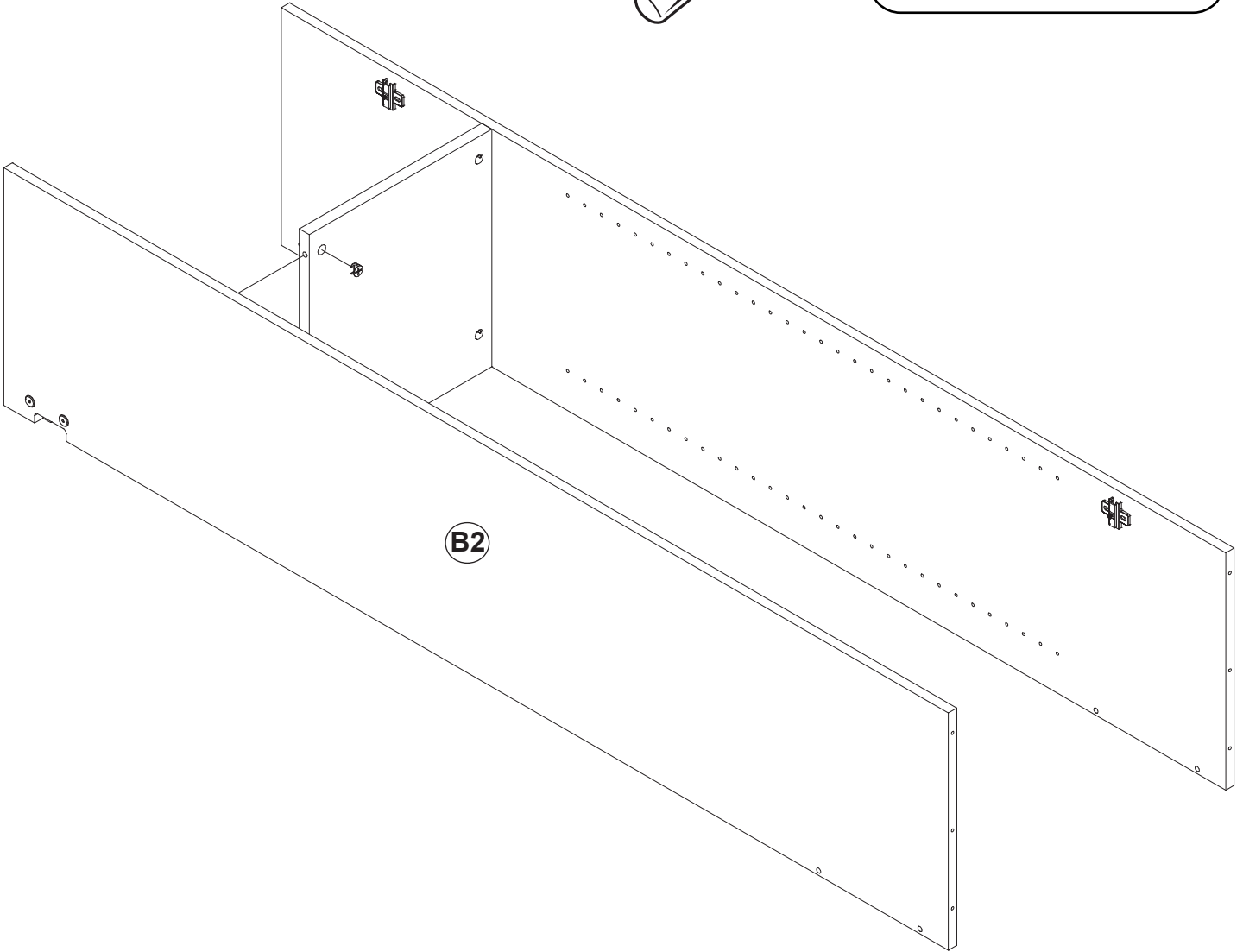
A small icon of a screw with a cross-shaped head and a threaded shaft.

A diagram enclosed in a rounded rectangle showing the locking mechanism. It includes an open padlock icon, a circular arrow with a crosshair, the text 'X2', a circular arrow with a gear, and a closed padlock icon. A screwdriver tip is shown above the circular arrows.

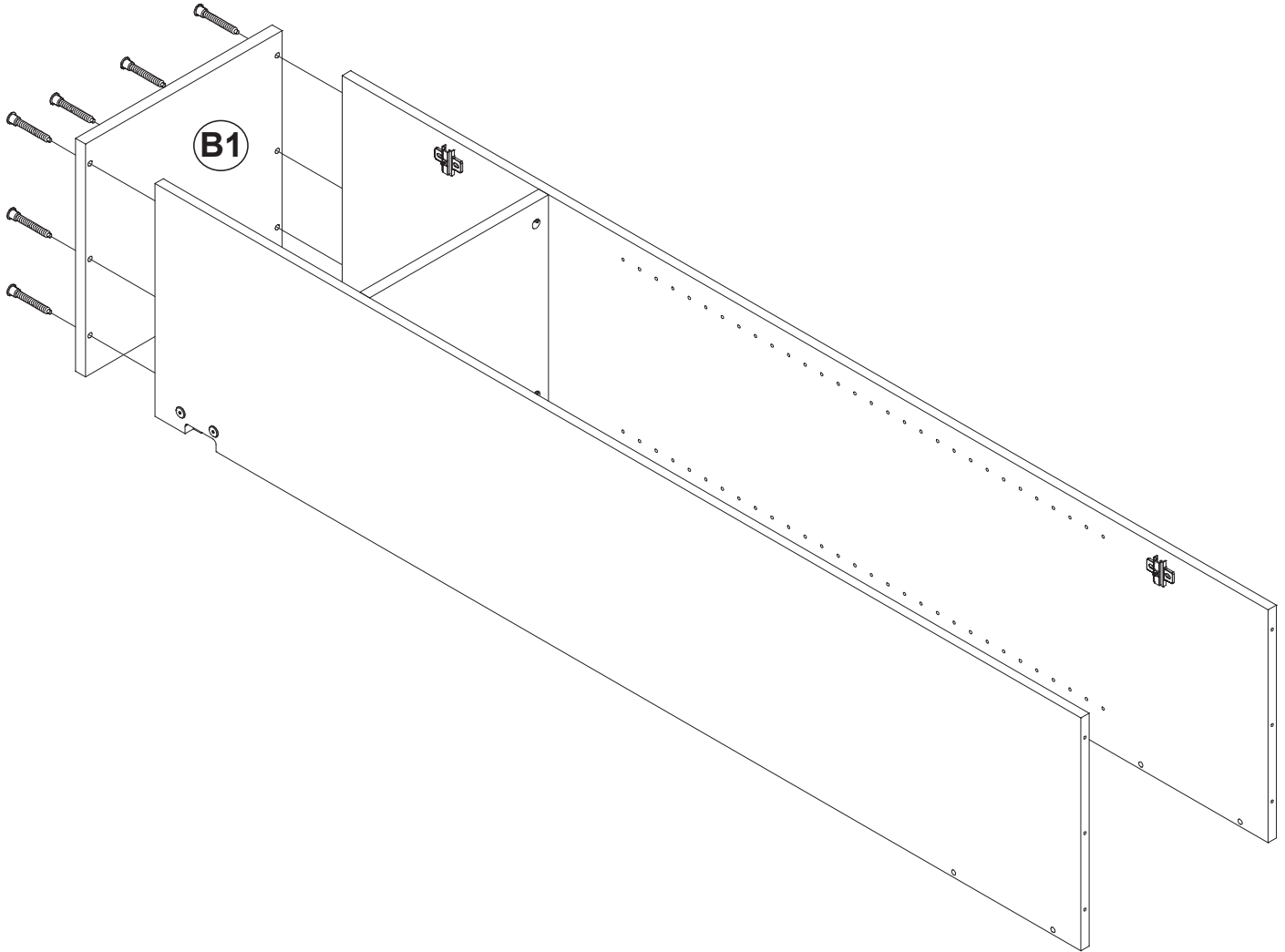
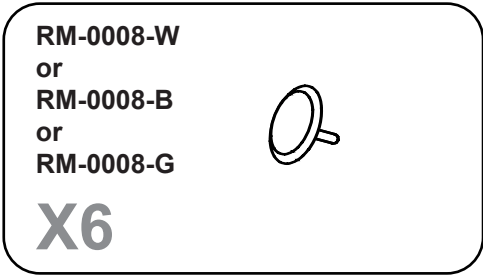
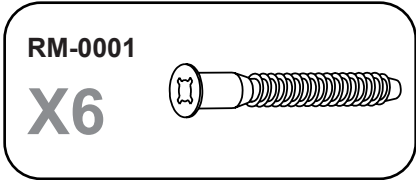
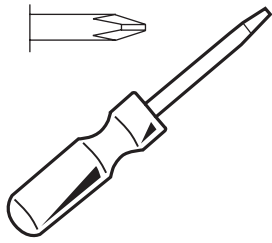

5

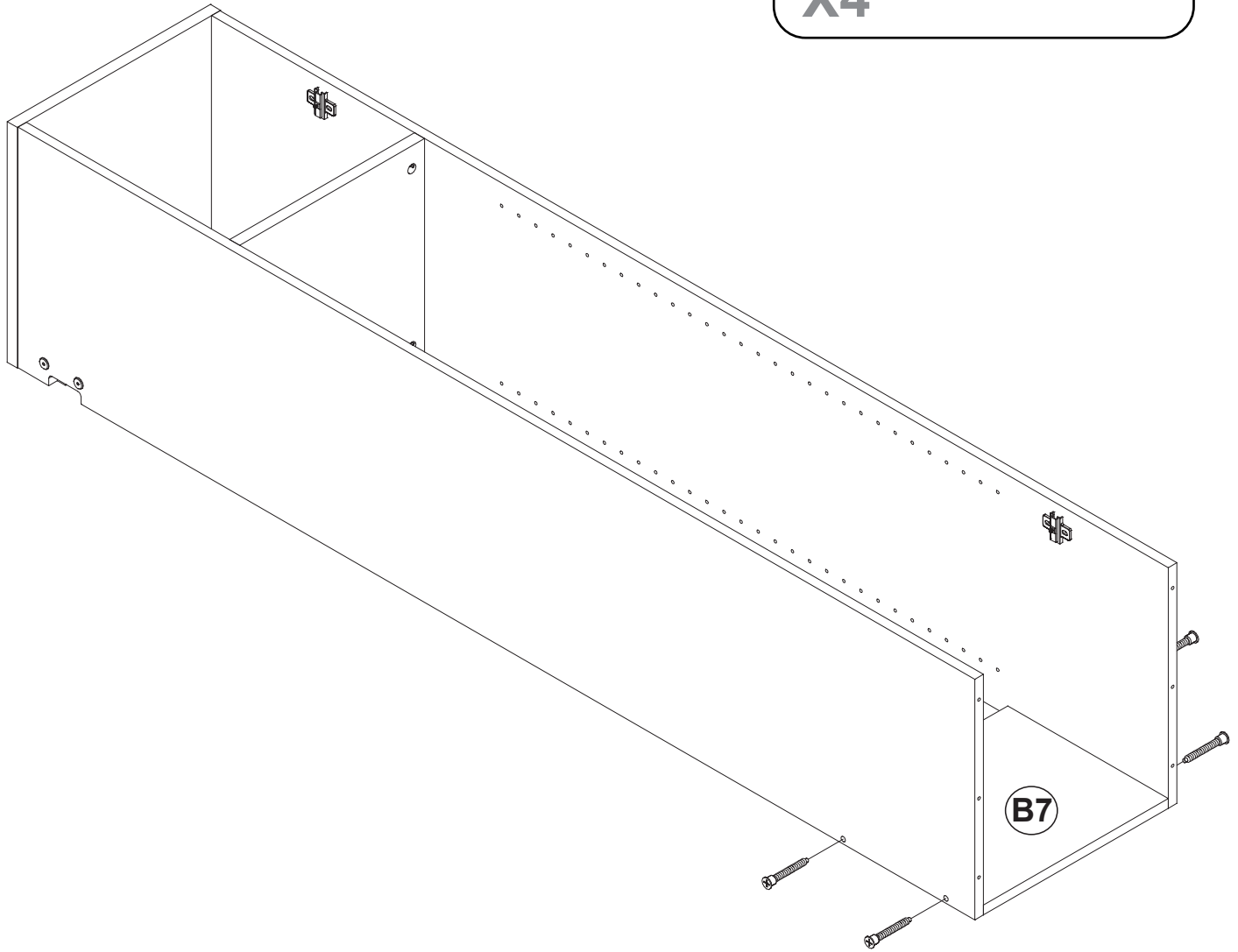
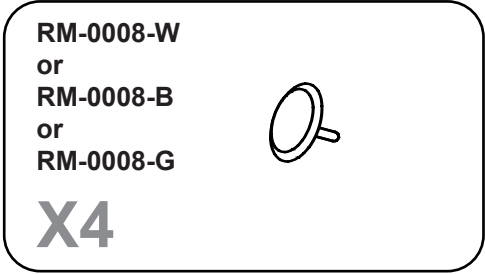
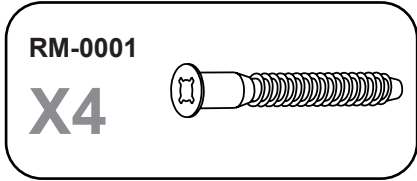
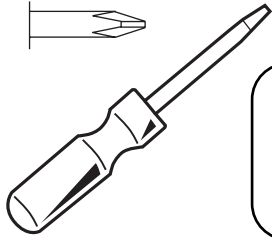

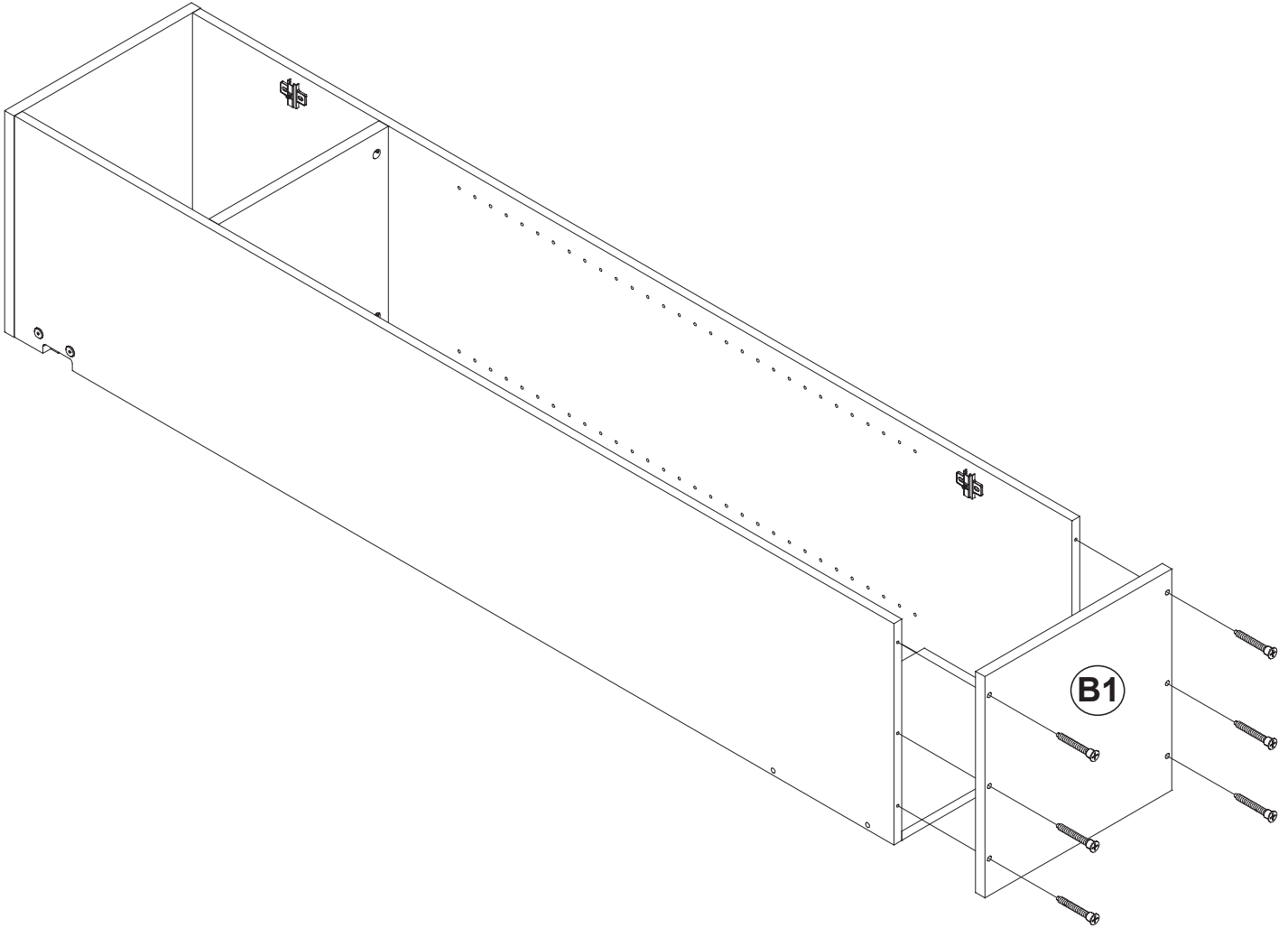
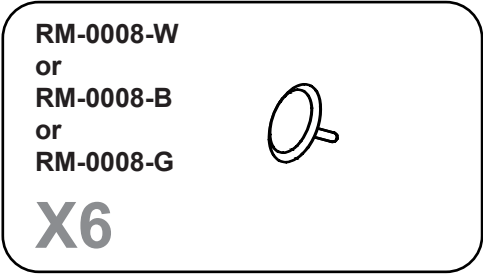
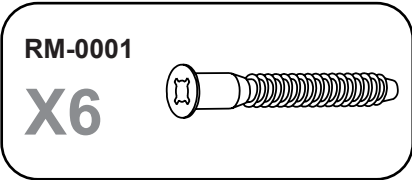
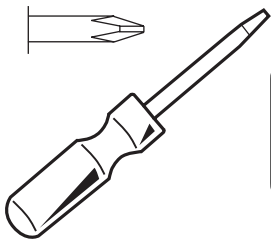

7

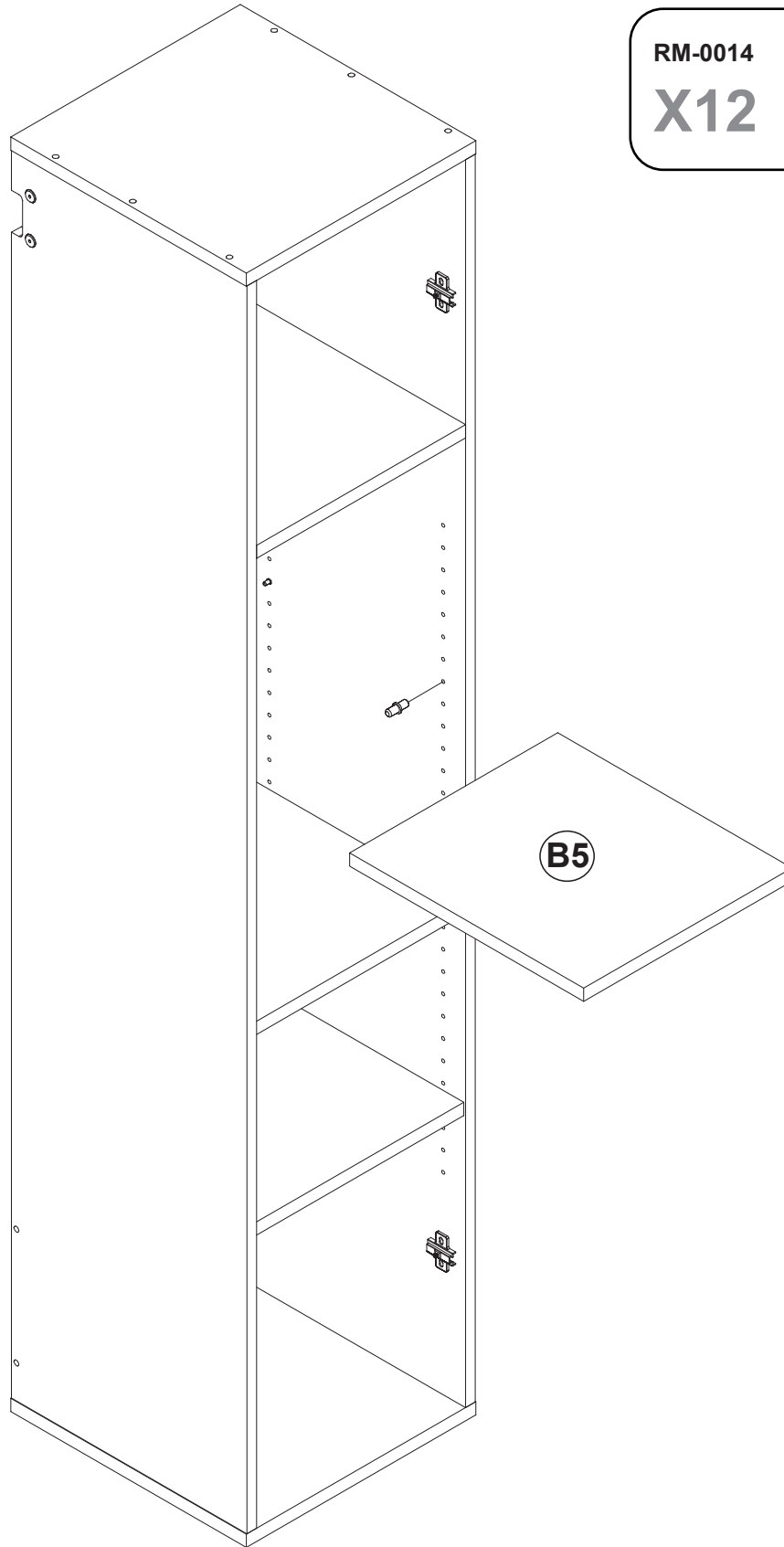

RM-0014
X12

3/16th inch (5mm)
3/16^{ième} de pouce de diamètre

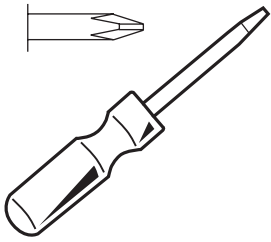

RM-0004
X4

A Phillips screw with a cross-shaped head and a threaded shaft.

RM-0016
X2

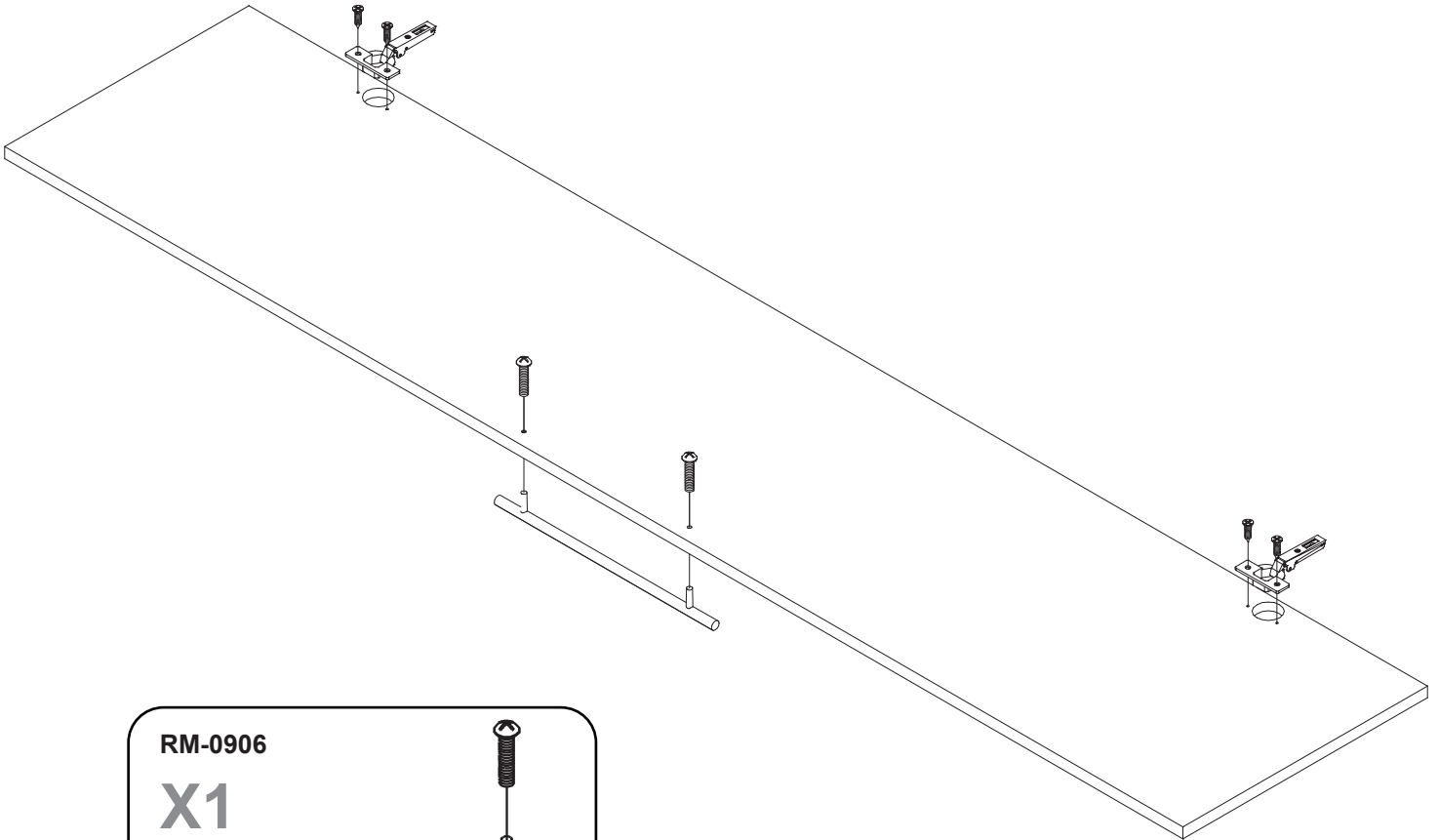
A metal hinge mechanism with two rectangular plates and a central pivot point.

RM-0906
X1

A long screw with a cross-shaped head and a threaded shaft, shown being inserted into a metal strip.

9

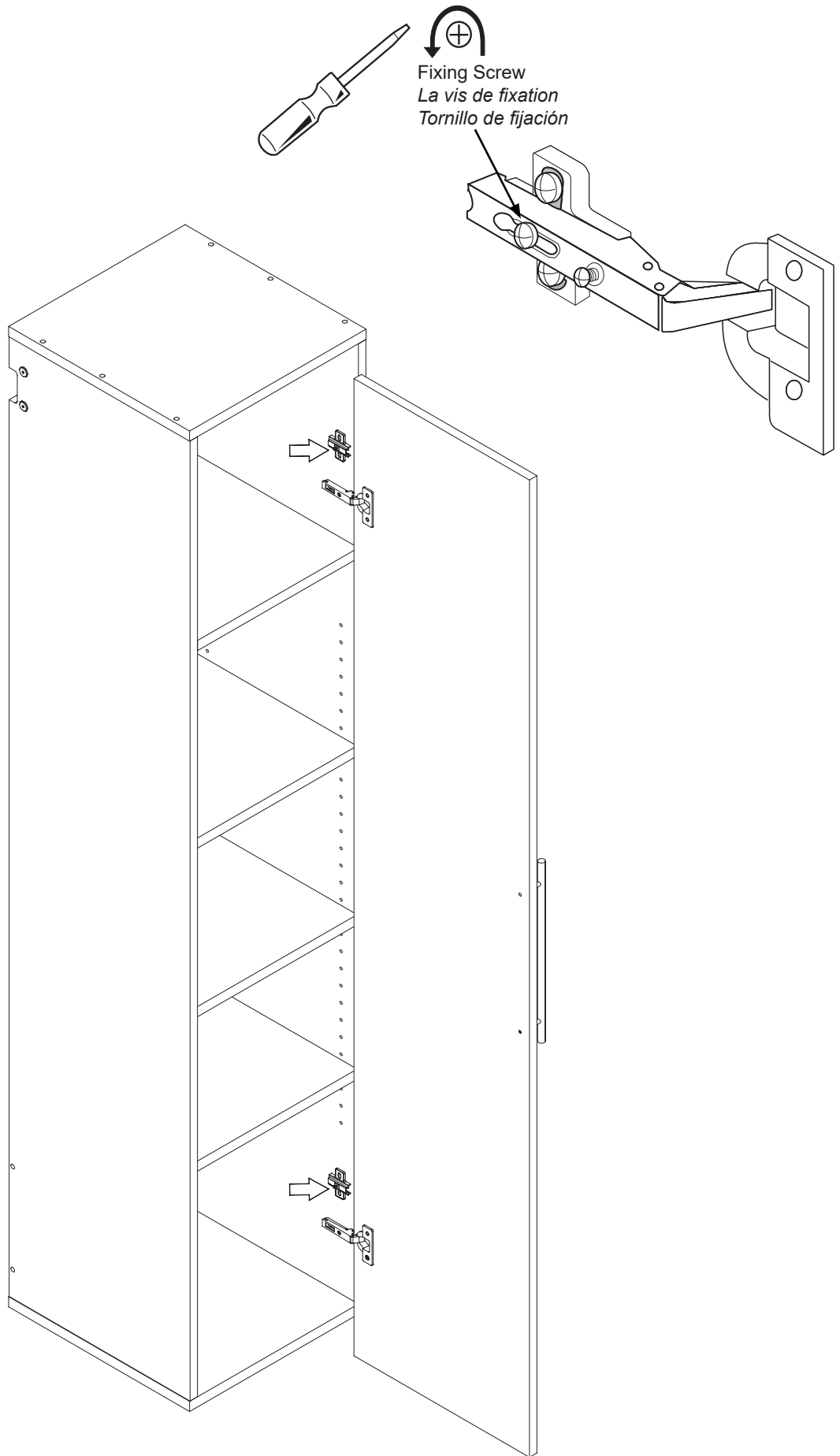

Hinge Adjustments

Hinges are 6-way adjustable, allowing you to make precise adjustments.

Ajustements de charnière

Les charnières sont 6-voies réglables, vous permettant d'effectuer des réglages précis.

Ajustes de bisagra

Las bisagras son ajustables en 6 direcciones, permitiéndole hacer ajustes precisos.

Vertical Door Alignment:

Loosen the top & bottom Hinge Plate Screws (on both hinge sets) and move the door up or down.

Alignement de la porte verticale:

Desserrer le haut & bas plaque charnière vis (sur les deux charnières) et déplacer la porte vers le haut ou vers le bas.

Alineación vertical de la puerta:

Afloje los tornillos de la placa de la bisagra superior e inferior (en ambos juegos de bisagras) y mueva la puerta hacia arriba o hacia abajo.

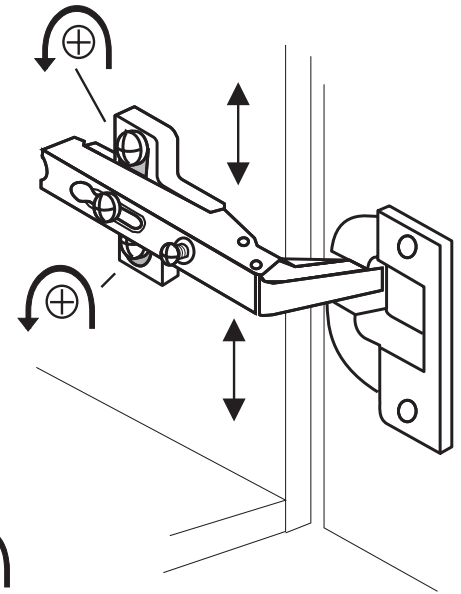
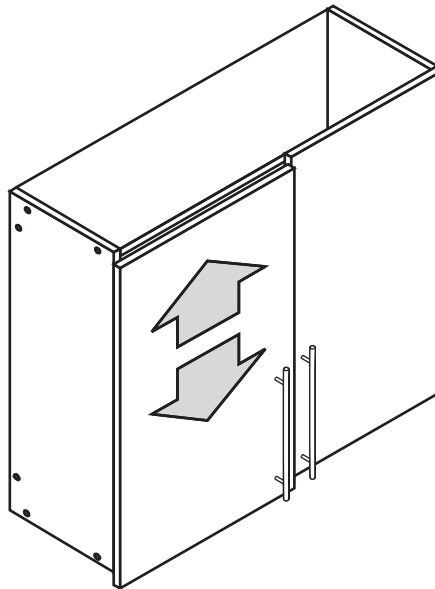

Adjust the space between the door and cabinet

Loosen the Fixing Screw and slide the door toward or away from the cabinet. Then, tighten the Fixing Screw.

Ajuster l'espace entre la porte et cabinet

Desserrer la vis de fixation et faites glisser la porte vers ou loin du cabinet. Ensuite, serrer les vis de fixation.

Ajusta el espacio entre la puerta y el armario.

Afloje el tornillo de fijación y deslice la puerta hacia o fuera del gabinete. Luego, apriete el tornillo de fijación

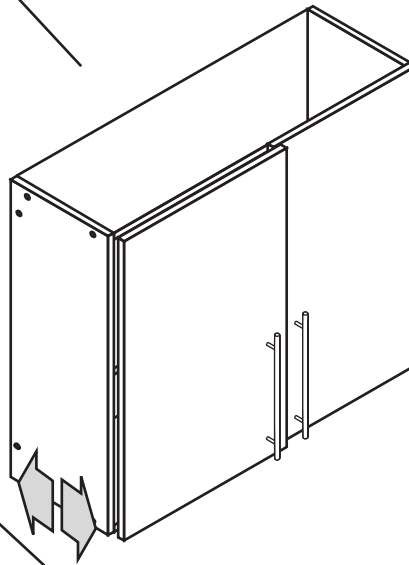

Fixing Screw
La vis de fixation
Tornillo de fijación

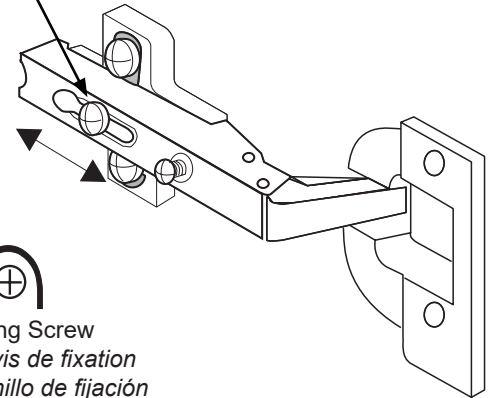

Fixing Screw
La vis de fixation
Tornillo de fijación

Adjust the space between the doors

- First, loosen the Fixing Screw
- To move the doors closer together, tighten the Adjustment Screw
- To move the doors farther apart, loosen the Adjustment Screw

Ajuster l'espace entre les portes

- D'abord, desserrez la vis de fixation
- Pour déplacer les portes plus étroite comprenant, serrer la vis de réglage
- Pour déplacer les portes plus loin à l'écart, desserrer la vis de réglage

Ajusta el espacio entre las puertas.

- Primero, afloje el tornillo de fijación
- Para acercar las puertas, apriete el tornillo de ajuste
- Para separar las puertas, afloje el tornillo de ajuste

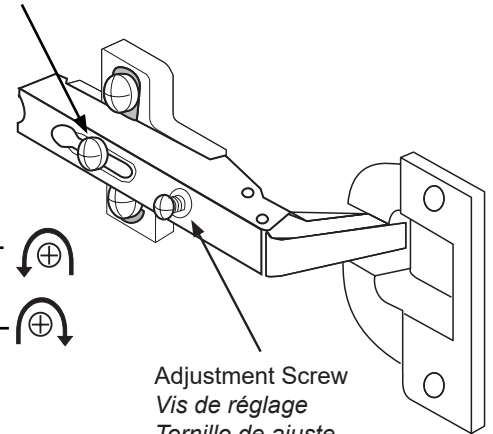
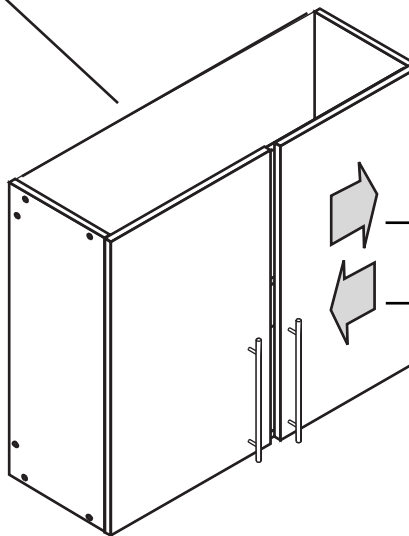

Adjustment Screw
Vis de réglage
Tornillo de ajuste

Installing Hang Ups Garage Cabinets

2 people required

Read through all installation steps before beginning

Pour suspendre les armoire au mur, vous aurez besoin de 2 personnes

Lisez bien toutes les étapes de cette installation avant d'entamer la tâche.

IMPORTANT:
Securely mounting the rails is critical for a proper installation.

The hardware and instructions provided are for walls built with drywall or sheetrock and **WOOD STUDS** positioned 16 inches apart. If you wish to hang product on other types of walls, please contact your local hardware store for the appropriate wall mounting hardware.

When using multiple Rails, a Connecting Brace is fastened across two adjoining rails to provide additional support between studs.

IMPORTANT :
fixation sécurisée des rails est critique pour une installation correcte.

Le matériel et les instructions sont fournies pour construire des murs de plâtre ou plâtre et goujons en bois placé 16 cm l'un de l'autre. Si vous souhaitez suspendre produit sur d'autres types de murs, veuillez contactez votre magasin de matériel informatique local pour le matériel de fixation murale.

Lors de l'utilisation de plusieurs rails, une connexion le renfort est fixé entre deux rails adjacents pour offrir un soutien supplémentaire entre les goujons.

Each cabinet comes with:

- One - 38 inch Metal Hanging Rail
- 1 Connecting Brace
- Three wood screws

Chaque armoire est livré avec :

- *Un - 38 pouces suspension métallique Rail •*
- *1 connexion renfort*
- *Trois vis à bois*

Before you begin:

Make sure you have the following tools and hardware:

- stud finder
- power screwdriver or drill
- 3/16th inch drill bit
- pencil
- Tape measure
- Level
- Hack saw *

*Optional: Use a hacksaw to cut the Metal Hanging Rail to the desired length.

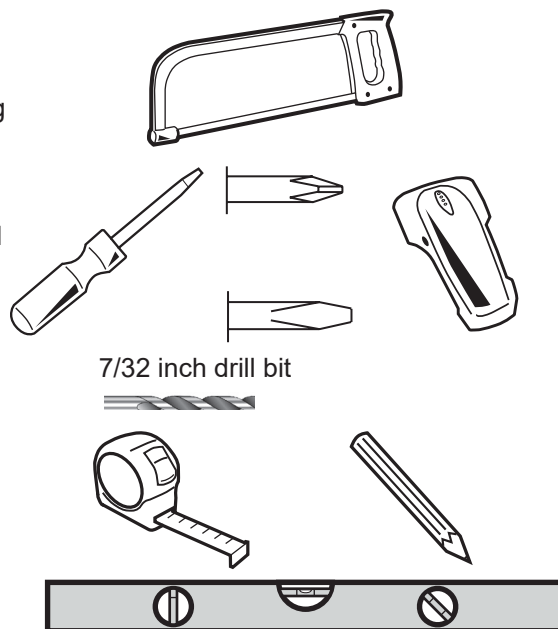

Avant de commencer :

Assurez-vous que vous disposez des outils suivants et matériel:

- *goujon finder*
- *tournevis électrique ou percer*
- *3/16ème pouces foret*
- *crayon*
- *ruban à mesurer*
- *niveau*
- *scie à métaux **

**Facultatif : Utilisez une scie à métaux pour couper le métal Rail de suspension à la longueur désirée.*

Hanging a Single 15" Cabinet

If you are installing one cabinet only, make sure the metal rail covers **3 studs** and center the cabinet across the studs.

Accrocher une seule armoire 15 po.

Si vous installez un seul cabinet uniquement, assurez-vous que le rail métallique couvre 3 goujons et centre le cabinet partout les goujons.

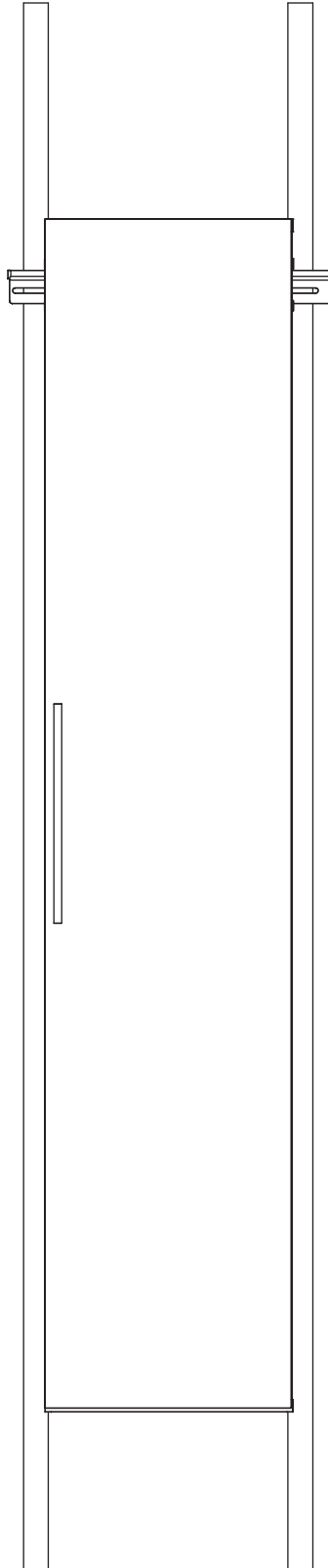

OR

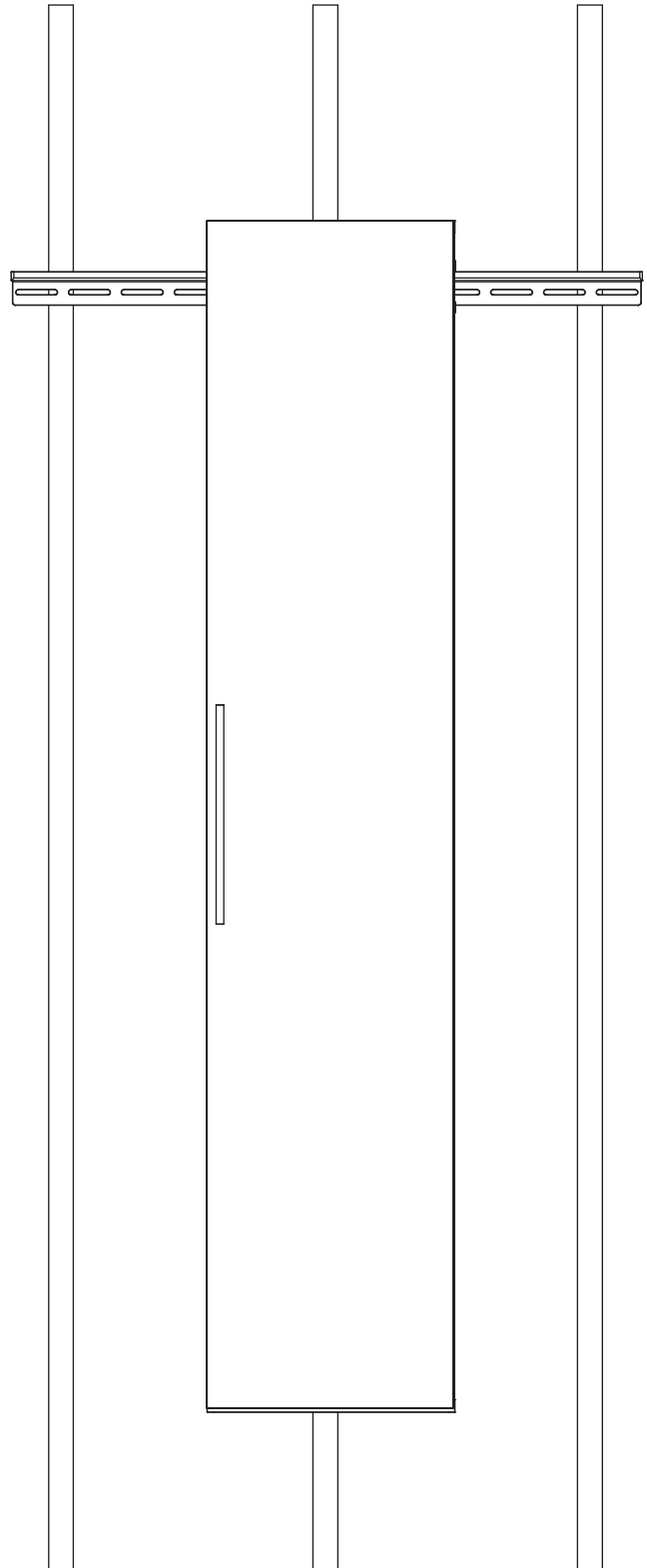

Hanging Multiple Cabinets

We will illustrate how hang multiple cabinets using the sample configuration below.

1. On your wall, mark where the cabinets will be positioned with tape or a pencil
2. Determine the number of Metal Rails and Connecting Braces needed. You may not need all rails
3. **For the Lower Drawer Cabinets in this configuration, you will need to CUT two Metal Rails**

Pour suspendre plusieurs armoires

Nous allons illustrer comment accrocher plusieurs armoires à partir de l'exemple de configuration ci-dessous.

1. Sur votre mur où les armoires seront positionnées, marquez d'une bande ou d'un crayon
2. Déterminer le nombre de rails métalliques et reliant les renforts nécessaires. Vous n'avez pas besoin de tous les rails.
3. **Pour le tiroir inférieur armoires dans cette configuration, vous devrez DÉCOUPER deux rails métalliques.**

Tall & Upper Cabinets

Armoires grande et supérieur

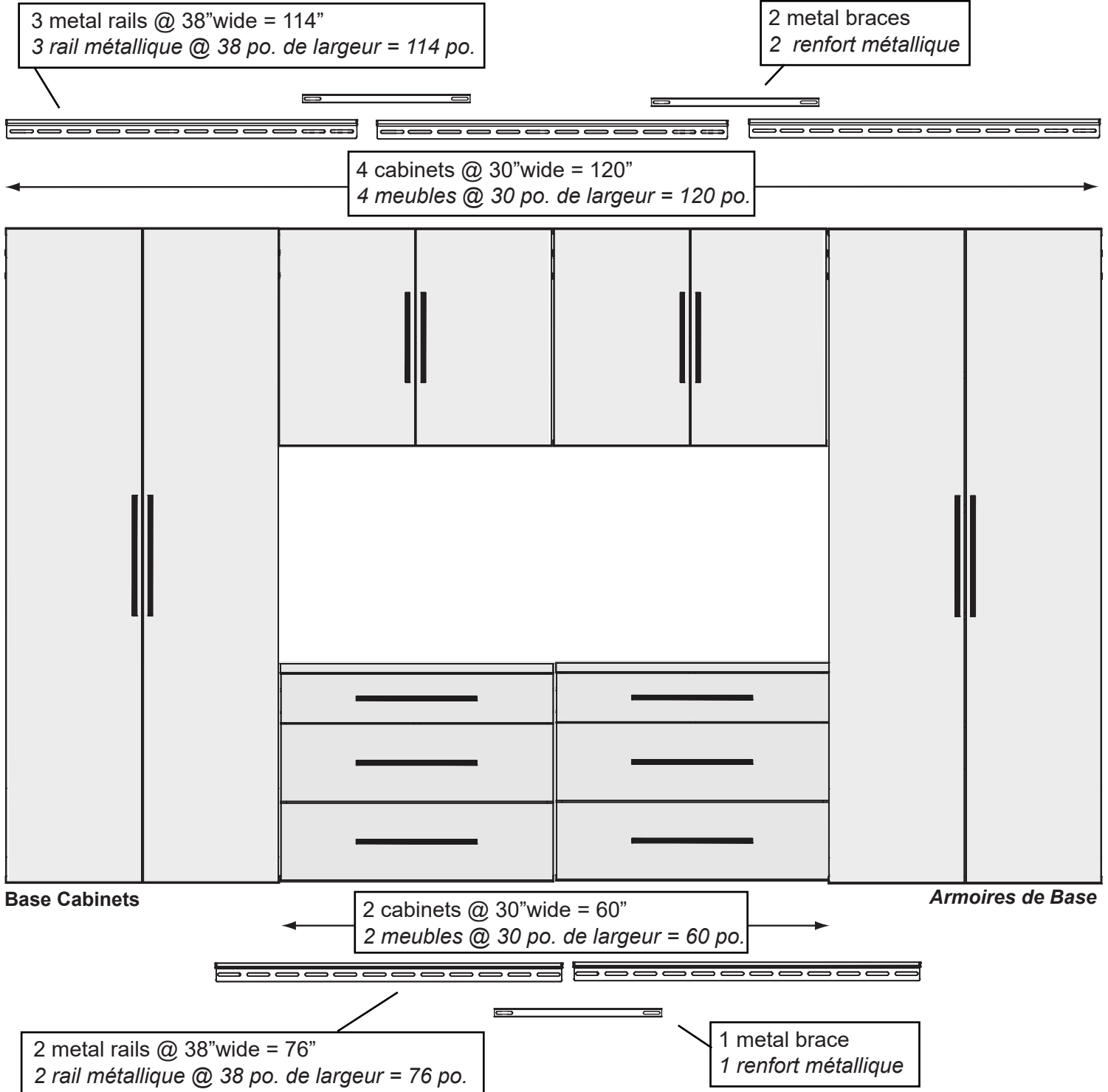

The illustration below shows where the Metal Rails & Connecting Braces should be attached to the wood studs for this configuration

L'illustration ci-dessous montre où les rails métalliques & la connexion les accolades ne doivent être connectés au bois goujons pour cette configuration

NOTE: Rails and Braces are shown ABOVE cabinets for clarity

REMARQUE : Les rails et les accolades sont indiqués ci-dessus les armoires pour plus de clarté

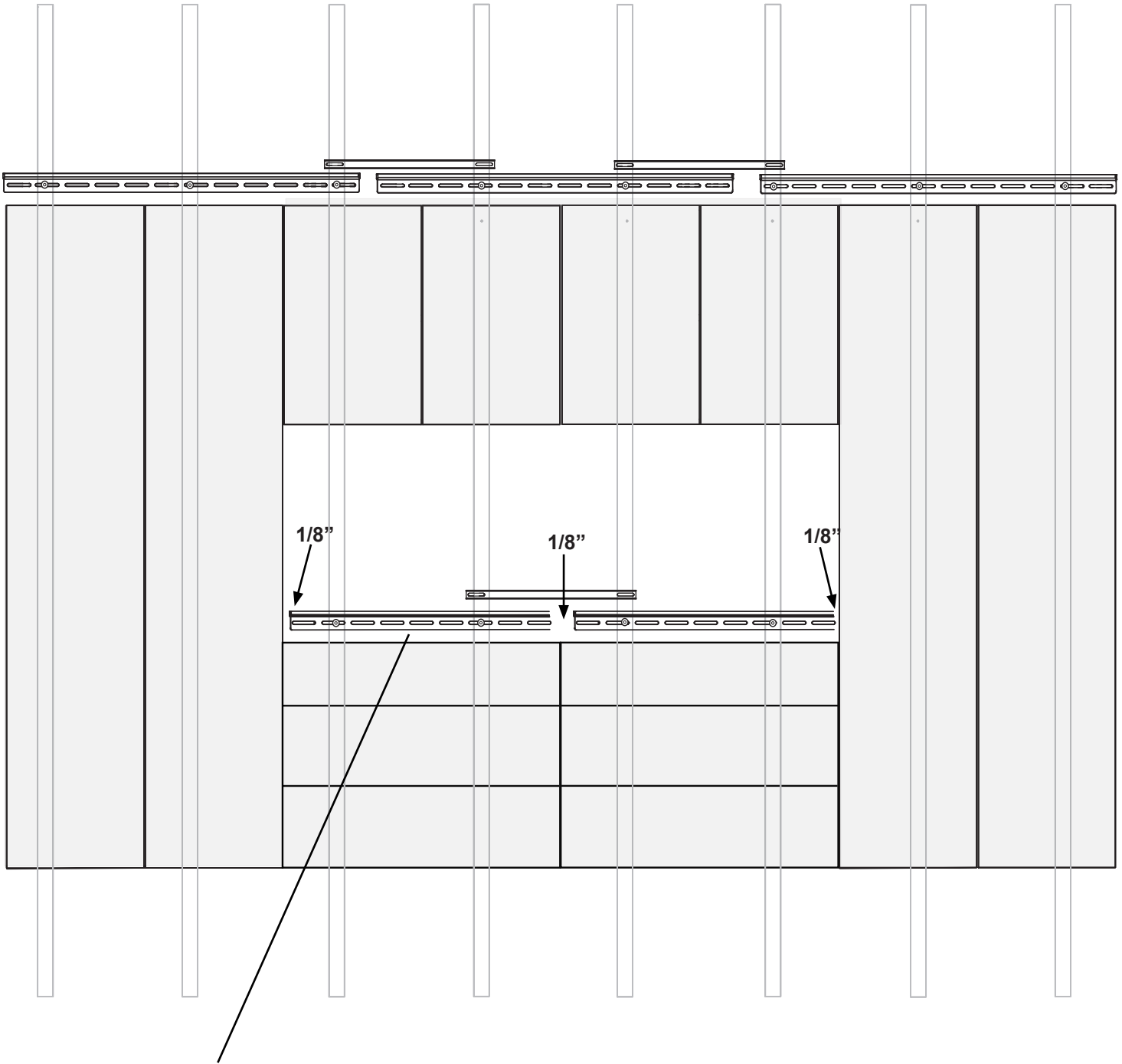

For the Base Cabinets, cut BOTH METAL RAILS.
Each rail should be attached to TWO STUDS

Pour les armoires de base, COUPER LES DEUX RAILS MÉTALLIQUES. Chaque rail devrait être jointe à DEUX GOUJONS

Installing Hang Ups Garage Cabinets

Installation "Hang Ups" Garage armoires

- 1 Measure 79½ inches from the floor and make multiple marks along the wall

Mesurer 79½ pouces du sol et faire plusieurs repères le long du mur

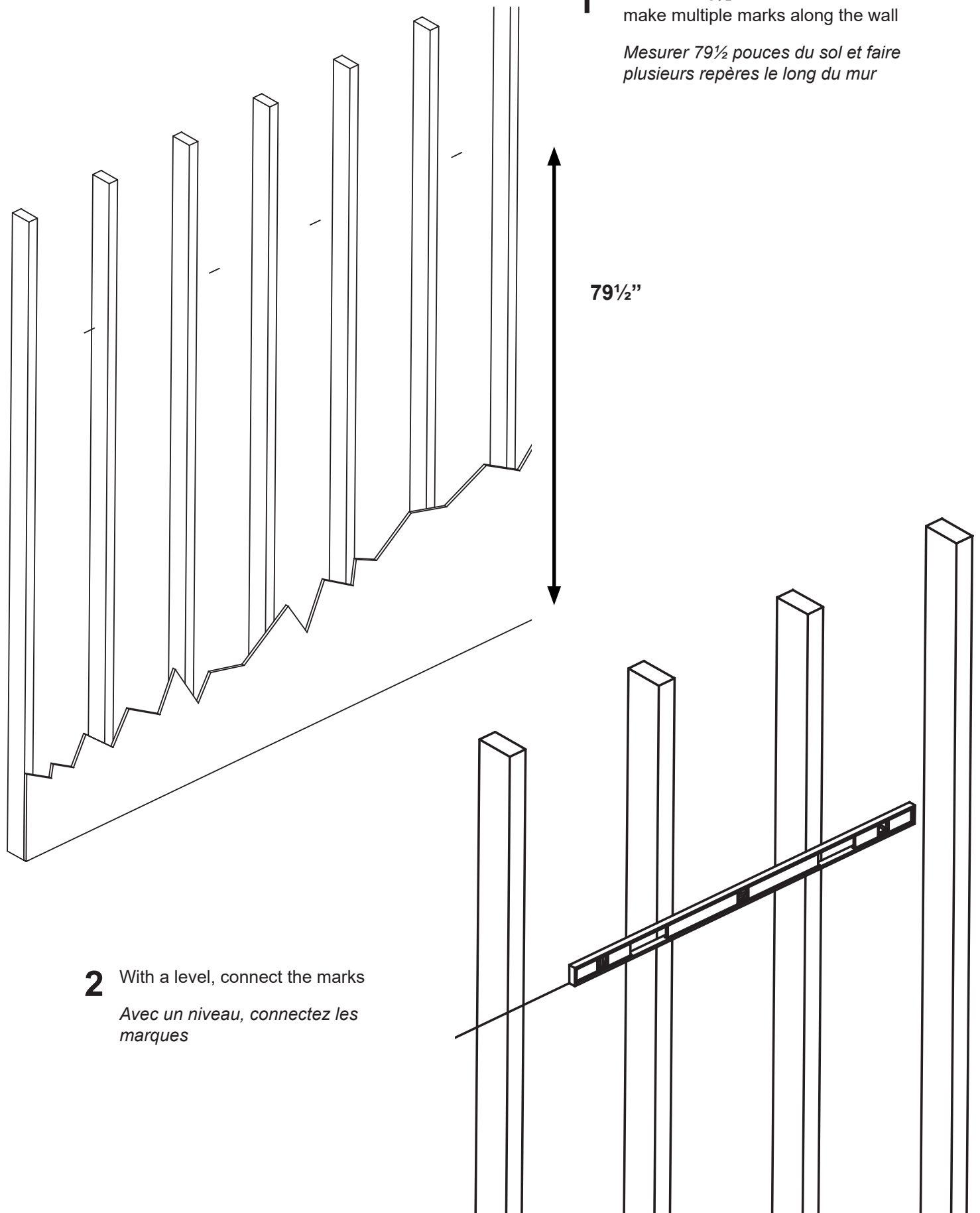

- 2 With a level, connect the marks
Avec un niveau, connectez les marques

3a

Find the center of the wall studs and mark the location of each stud along the line. Studs are typically 16 inches apart center to center.

Trouver le centre du mur et marquer l'emplacement de chaque goujon le long de la ligne. Les goujons sont généralement de 16 centimètres l'un de l'autre centre à centre.

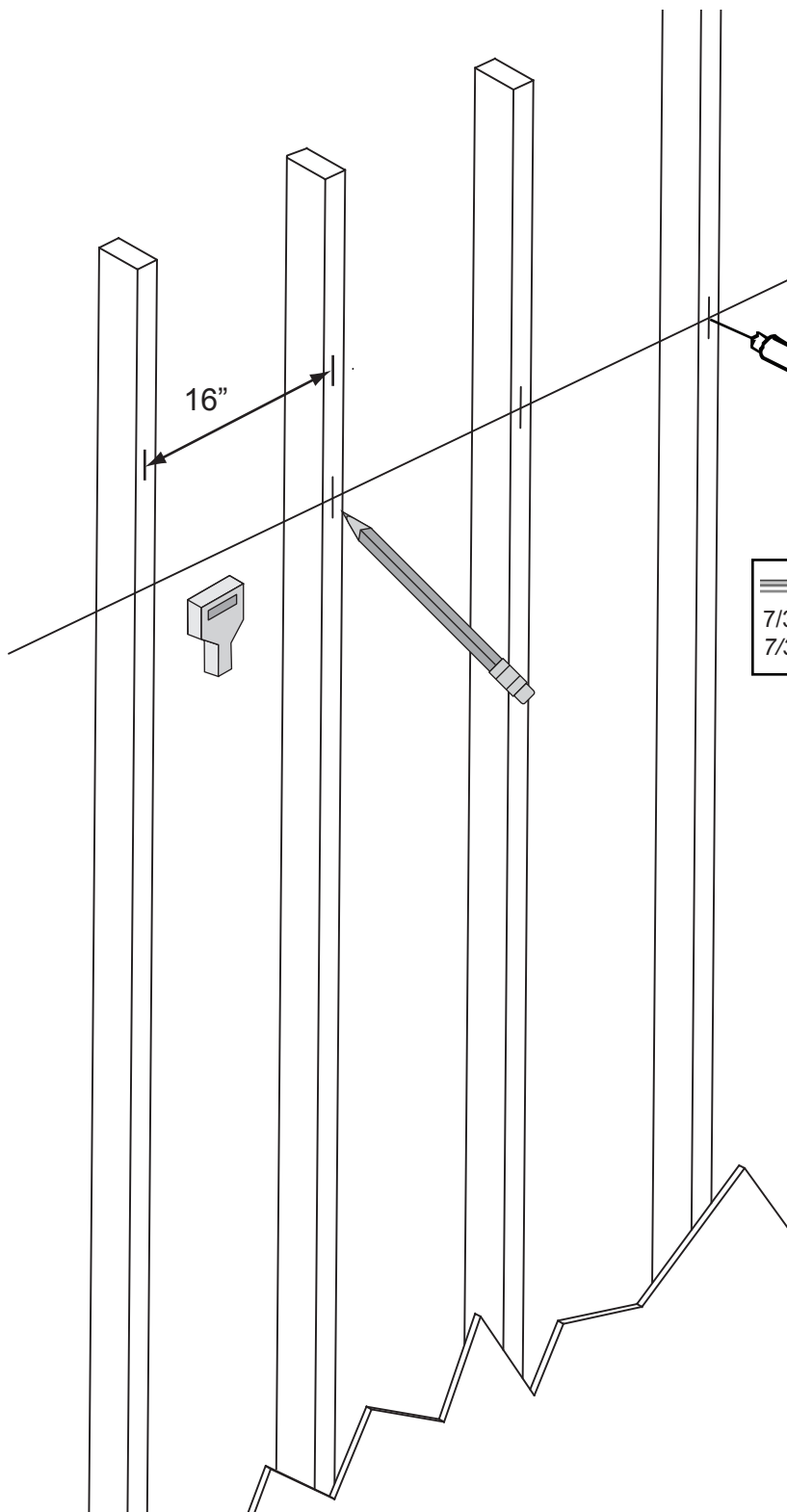
**3b**

Pre-drill holes 3 inches deep at the locations you had marked. Use a 7 / 32 nd inch drill bit

Faites trois perforations de 3 pouces de profondeur aux points que vous avez marqué dans l'étape précédente. Utilisez une mèche de 7 / 32 de pouce.

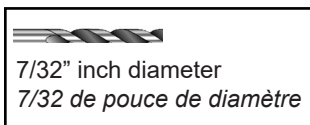
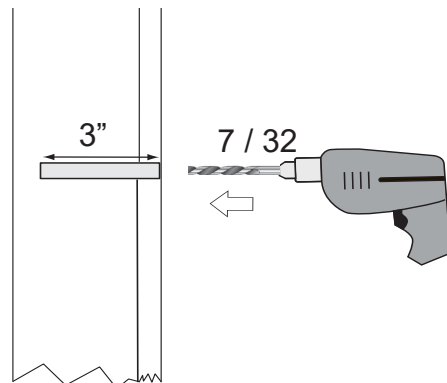

4 Hang the First Rail *Accrocher la première position de Rail*

Position the Metal Rail over the pre-drilled holes and insert wood screws into the first & second holes. Tighten screws with the Allen Key provided.

Positionnez la piste de métal sur les trous pré-perçés et insérez les vis à bois dans le premier & deuxième trous. Serrer les vis avec la clef Allen fournie.

5 Attach the Connecting Brace *Fixez le renfort reliant*

Position the Connecting Brace so that it overlaps the last hole on the First Metal Rail. Insert the remaining screw through both the Connecting Brace and the Metal Rail

Positionnez la raccordement entretoise de telle sorte qu'il chevauche le dernier trou sur le premier rail métallique. Insérer la vis restante tant par le biais de la connexion le renfort et le rail métallique

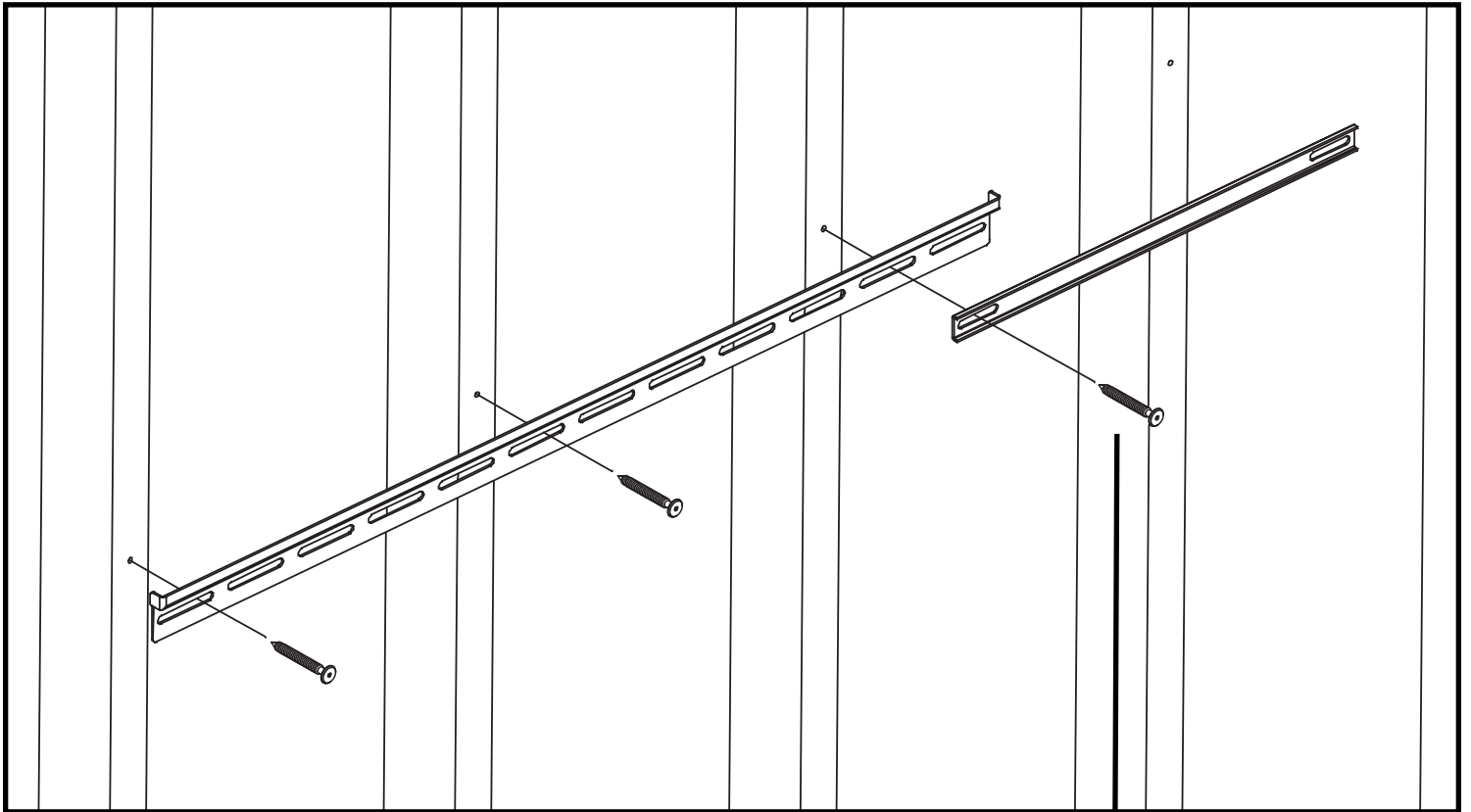

If you are installing one cabinet only, make sure the metal rail is centered across 3 studs and insert all 3 screws
Si vous installez un cabinet uniquement, assurez-vous que le rail métallique est centré sur 3 goujons et insérez les 3 vis

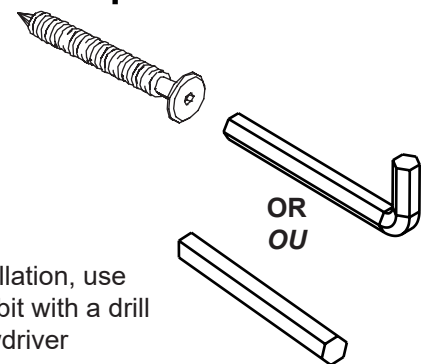
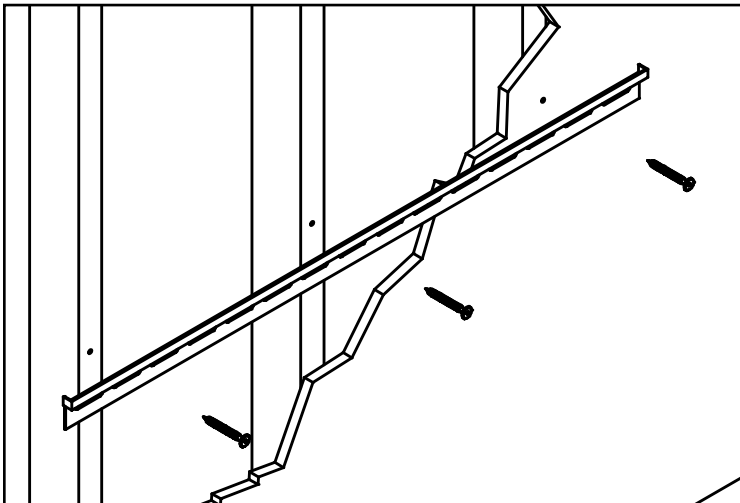

For faster installation, use the hexagonal bit with a drill or power screwdriver

Pour une installation plus rapide, utilisez une perceuse et fourni l'embout hexagonal

6

Hanging the Second Rail

Slide the second Metal Rail BEHIND the Connecting Brace

Secure the Connecting Brace to the Second Rail

Accrocher le deuxième position de Rail

Faites glisser le Rail Métallique deuxième derrière le connectant le renfort

Sécuriser la connexion renfort pour le deuxième rail

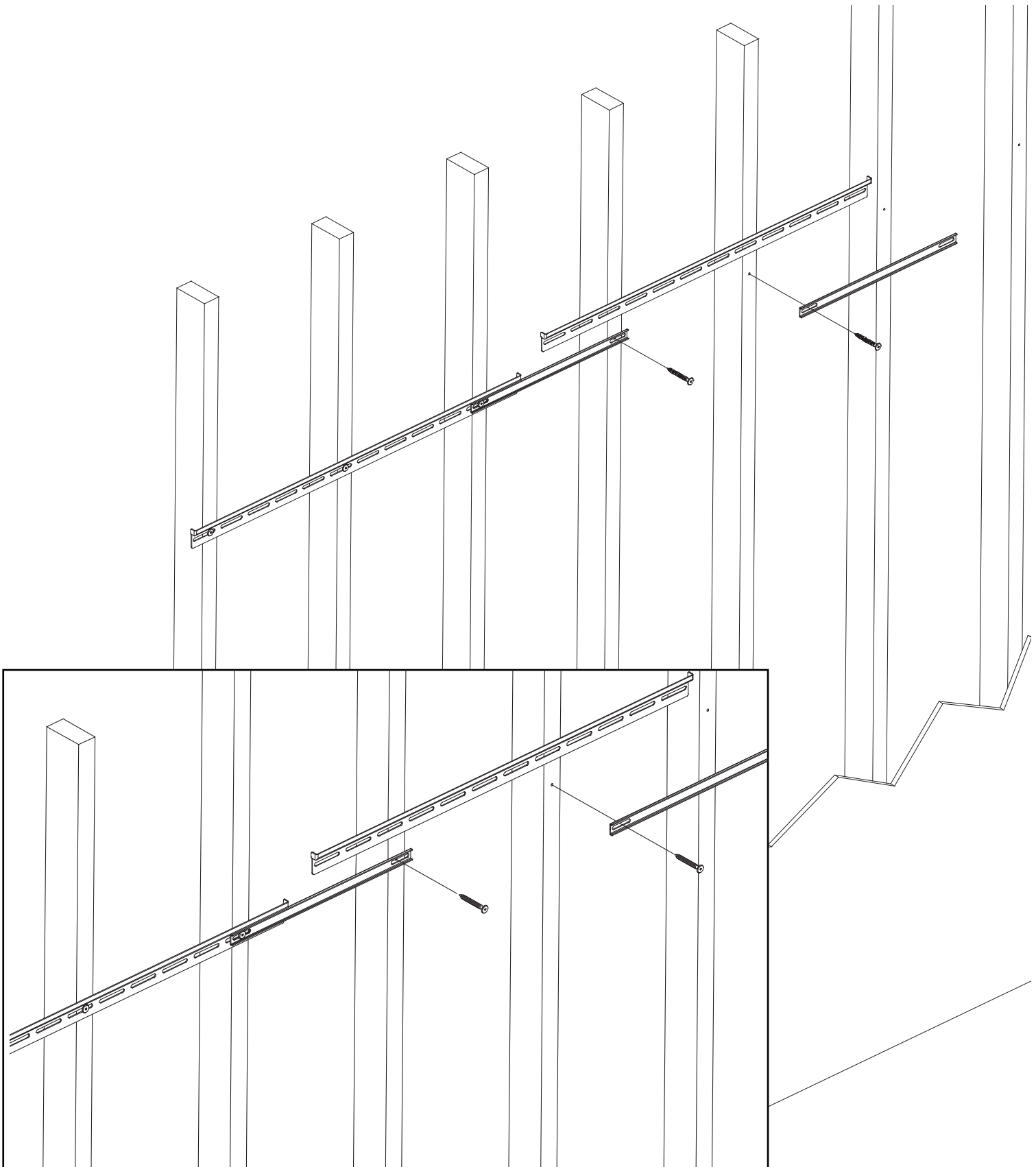

7

Carefully hang the cabinet onto the Metal Rail until it locks into place.

Laisser pendre soigneusement le cabinet sur la rail métallique jusqu'à ce qu'elle se verrouille en place.

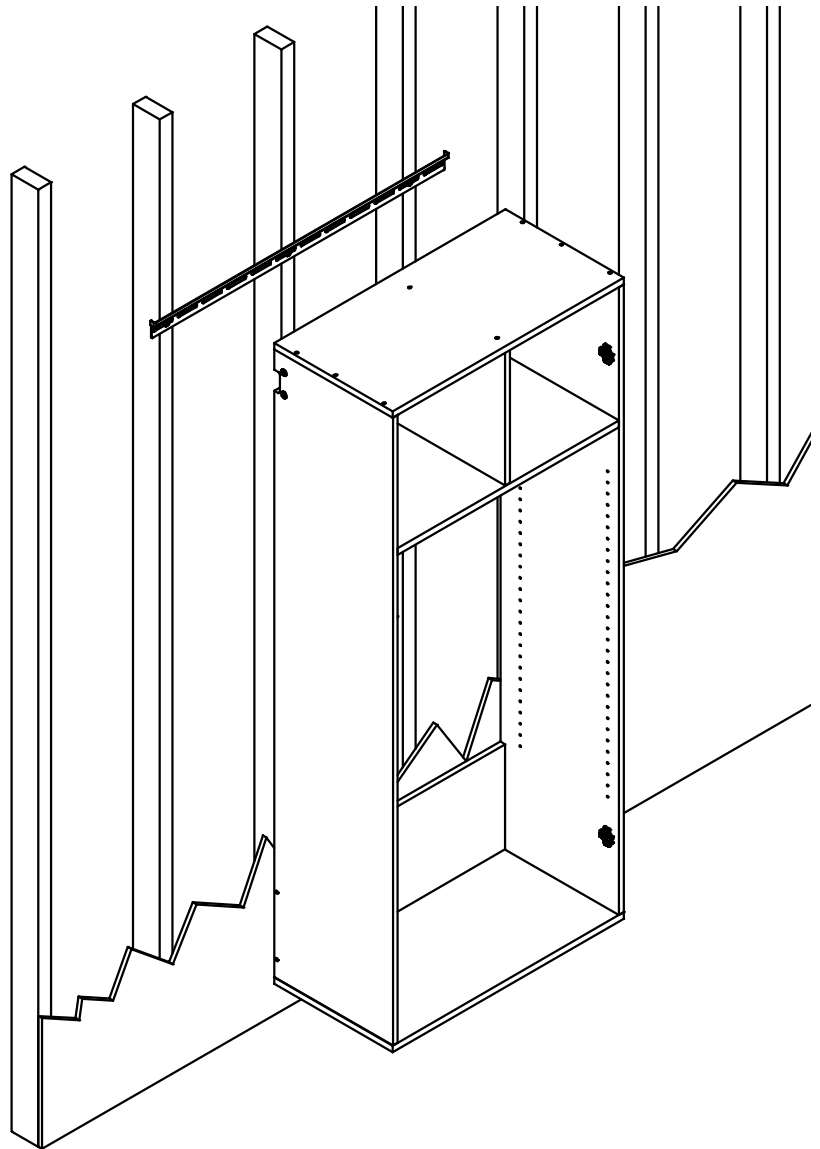

Make sure the Rail Hook slides fully into the notch on the Metal Rail Track.

Assurez-vous que le crochet de Rail de diapositives pleinement dans l'encoche du Metal voies de chemin de fer.

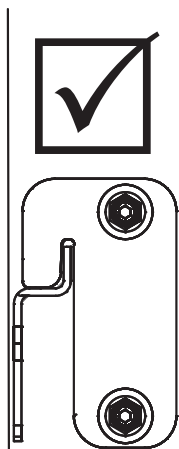

Wall
Mur

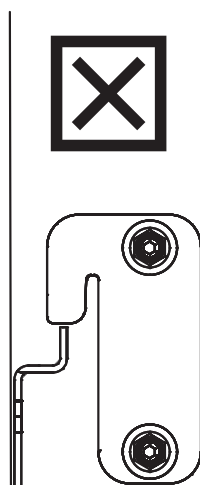

Wall
Mur

