

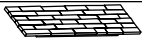





# ASSEMBLY INSTRUCTIONS

Thank you for purchasing this quality product. Be sure to check all packing material care fully for small parts, which may have come loose inside the carton during shipment. Identify and count all parts and compare with the **HARDWARE LIST** below.

NO.	DESCRIPTION	SKETCH	QTY
A	Bench Top		1PC
B	Leg L		2Pcs
C	Leg R		2Pcs
D	Metal Stretcher		1PC
E	Large Hex Nut		2Pcs
F	Base of Leg		2Pcs
G	Cushion		1Pc

NO.		HARDWARE LIST	QTY
1		Bolt (Ø1/4"x40mm)	8Pcs
2		Bolt (Ø1/4"x60mm)	4Pcs
3		Flat Washer (Ø1/4"x19x2mm)	12Pcs
4		Spring Washer (Ø1/4x11x2mm)	12Pcs
5		Allen Wrench 4mm	1Pc

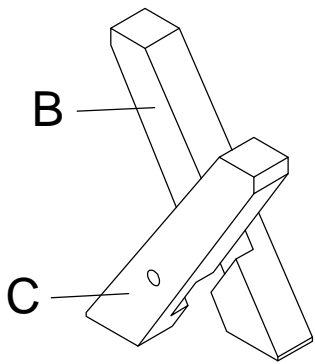

STEP 1

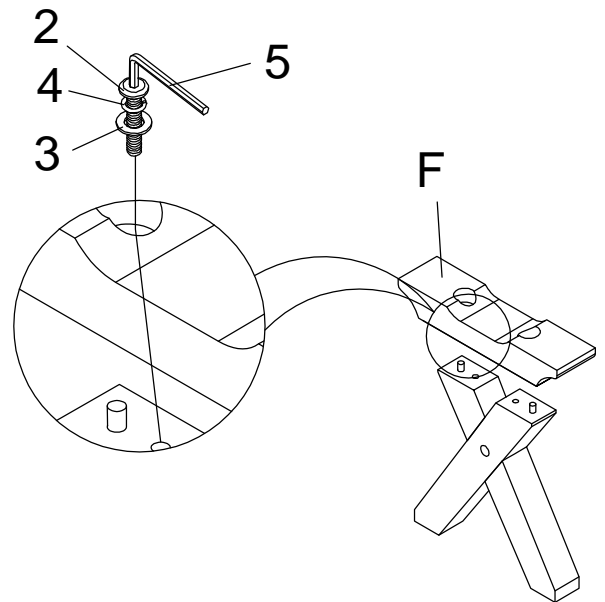

STEP 2

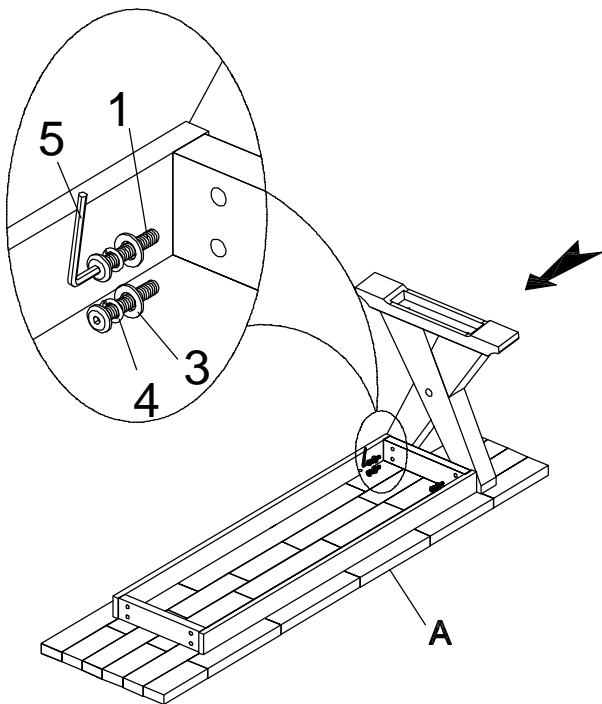

STEP 3

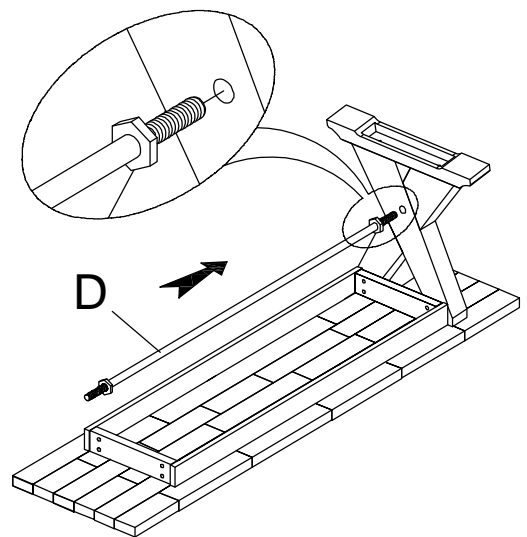

STEP 4

Note: Please **DO NOT** fully tighten all screws and bolts until the entire item is completely assembled

# ASSEMBLY INSTRUCTIONS

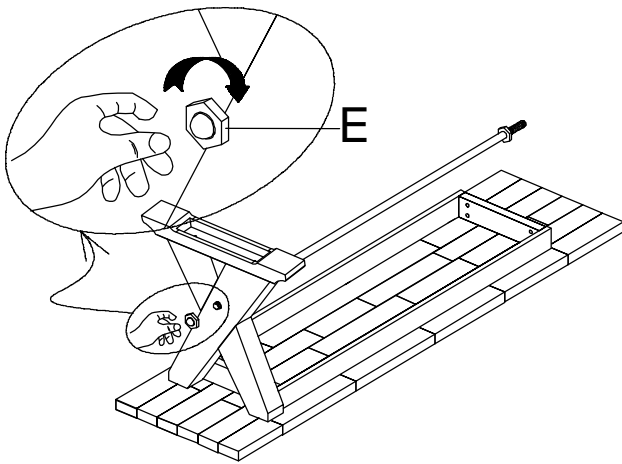

STEP 5

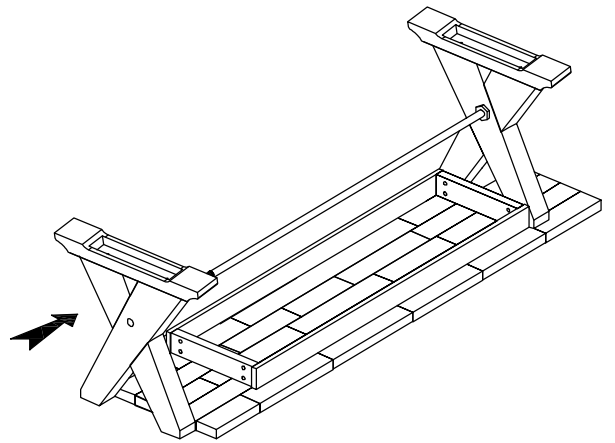

STEP 6

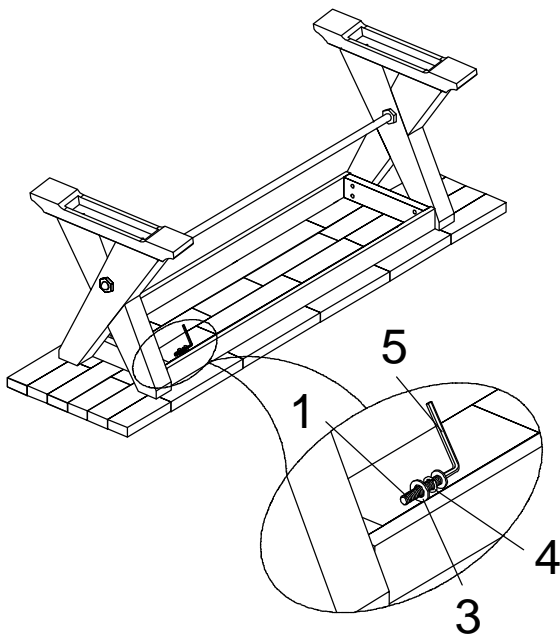

STEP 7

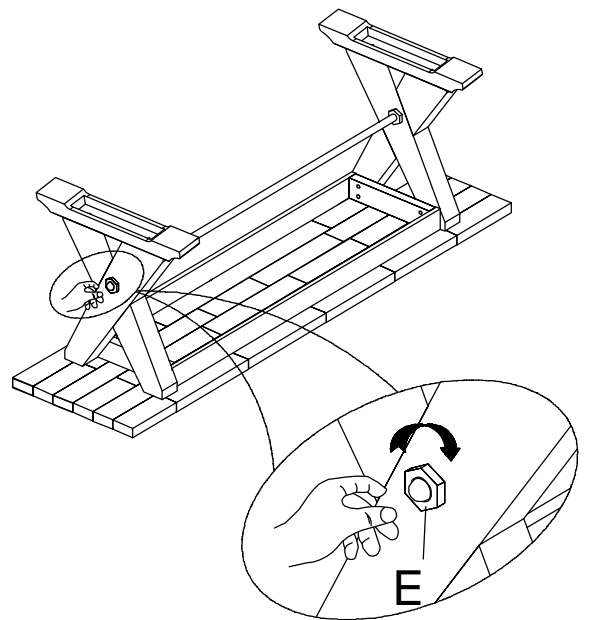

STEP 8

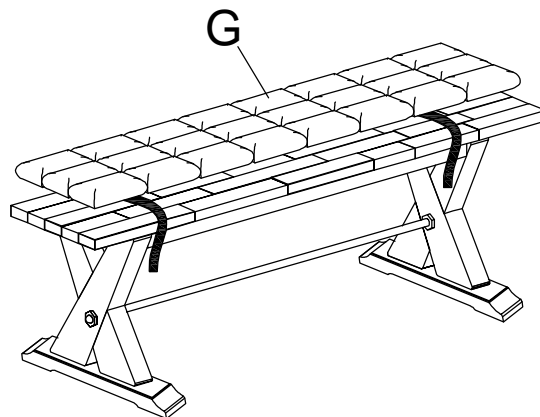

STEP 9

Note: Please DO NOT fully tighten all screws and bolts until the entire item is completely assembled