

# Assembly Instructions

## SIDE COFFEE TABLE

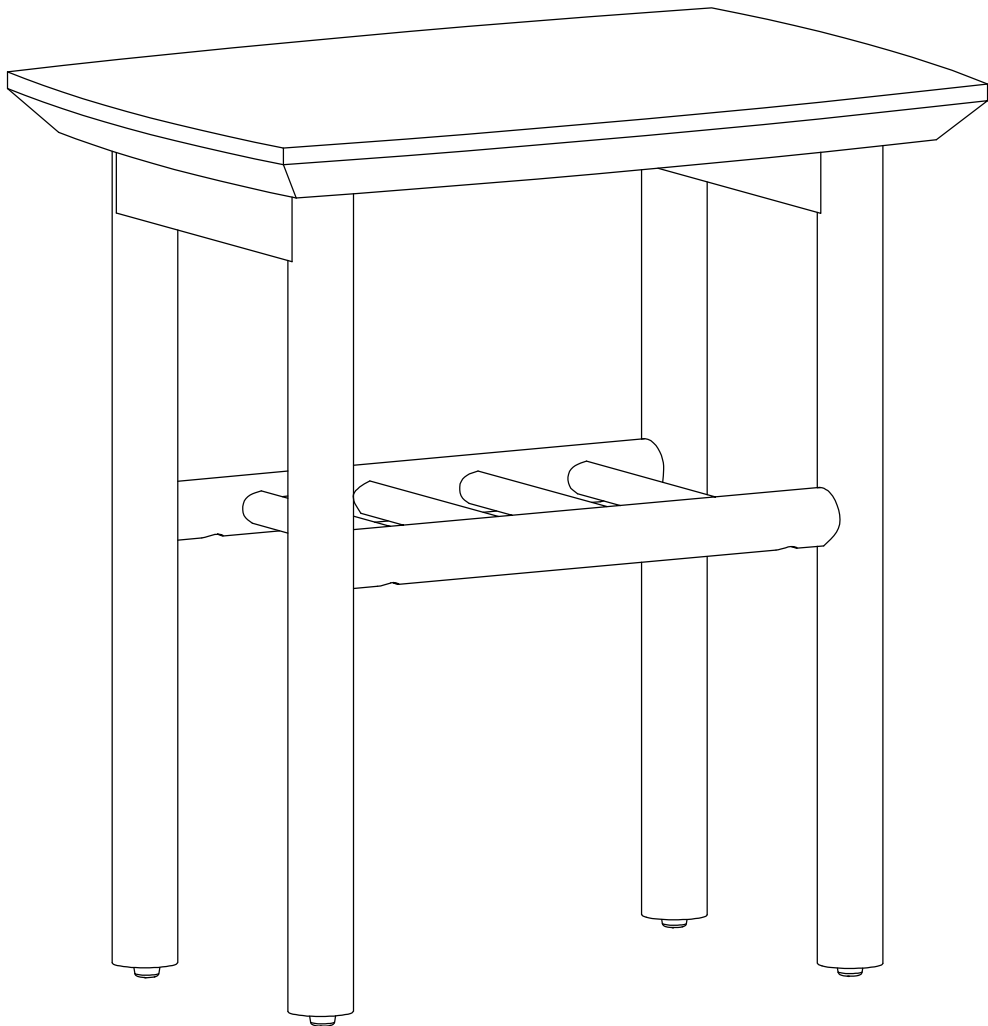







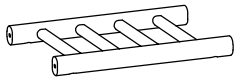
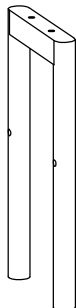

# SIDE COFFEE TABLE

## ASSEMBLY INSTRUCTIONS

Please kindly read these instructions carefully and keep for future reference. Refer to parts inventory for guidance, and ensure you have all pieces before starting. When assembling, place all parts on a soft, clean, and flat surface such as a carpet to prevent scratches. If you're having difficulty, our friendly Customer Care team is always here to help.



PART LIST		
ID	DESCRIPTION	QTY
(A)	 Top	1 pc
(B)	 Frame	1 pc
(C)	 Legs	2 pcs

HARDWARE LIST		
	Three in one connector screw	4 pcs
		
		
	Bolt M8x60	4 pcs
	Spring Washer Ø8.5xØ19	4 pcs
	Flat Washer Ø8.5xØ12	4 pcs
	Allen Key	1 pc

**Note: Make sure you have all the parts and hardware with quantity listed above before assembling the product. A screwdriver is also required (not included)**

# SIDE COFFEE TABLE

## STEP 1

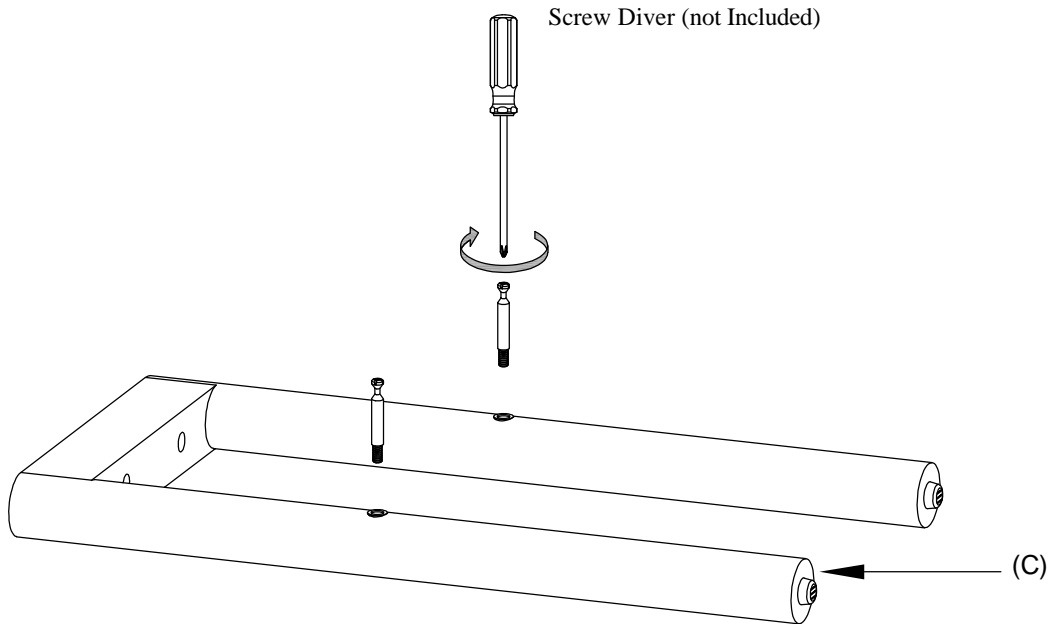

## STEP 2

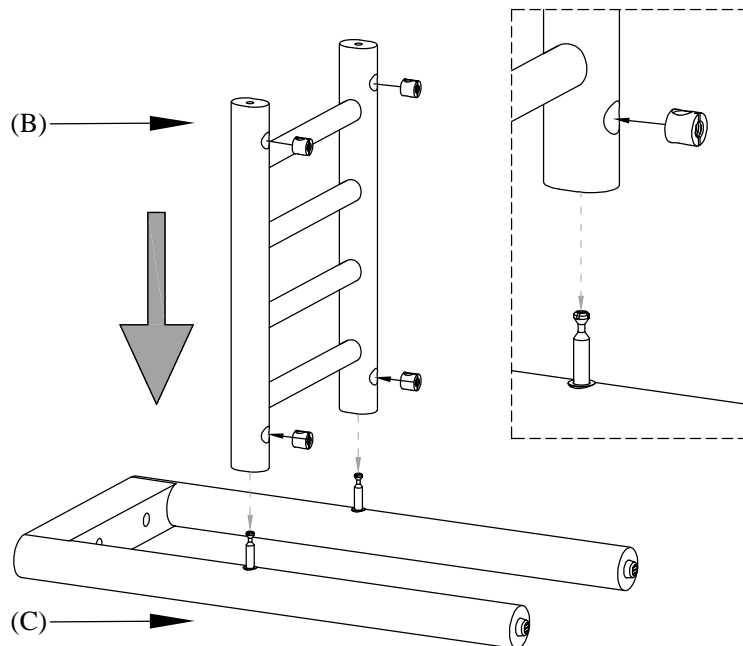

Note: DO NOT TIGHTEN ANY BOLT UNTIL ALL THE BOLTS ARE INSERTED PROPERLY

# SIDE COFFEE TABLE

## STEP 3

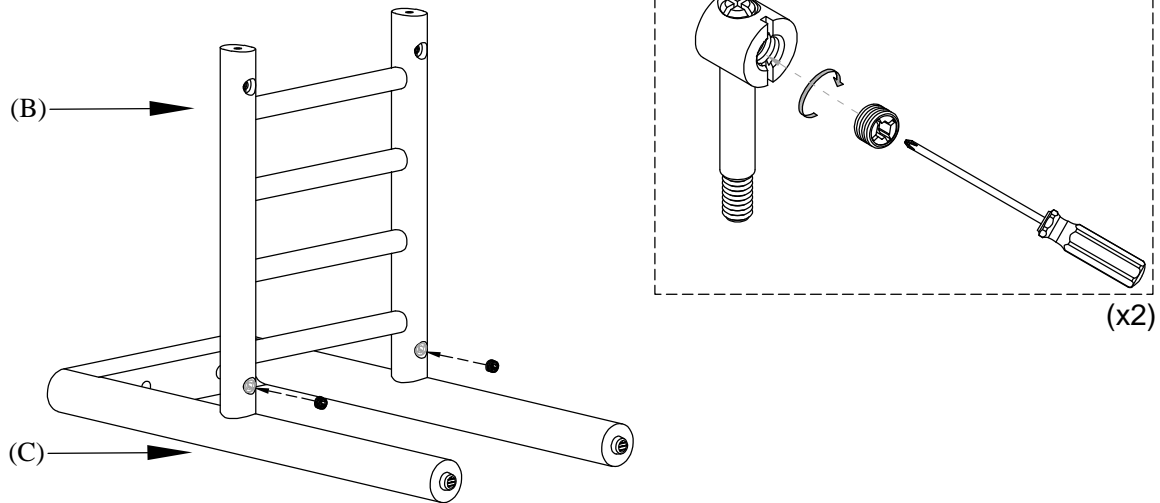

Note: DO NOT TIGHTEN ANY BOLT UNTIL ALL THE BOLTS ARE INSERTED PROPERLY

## STEP 4

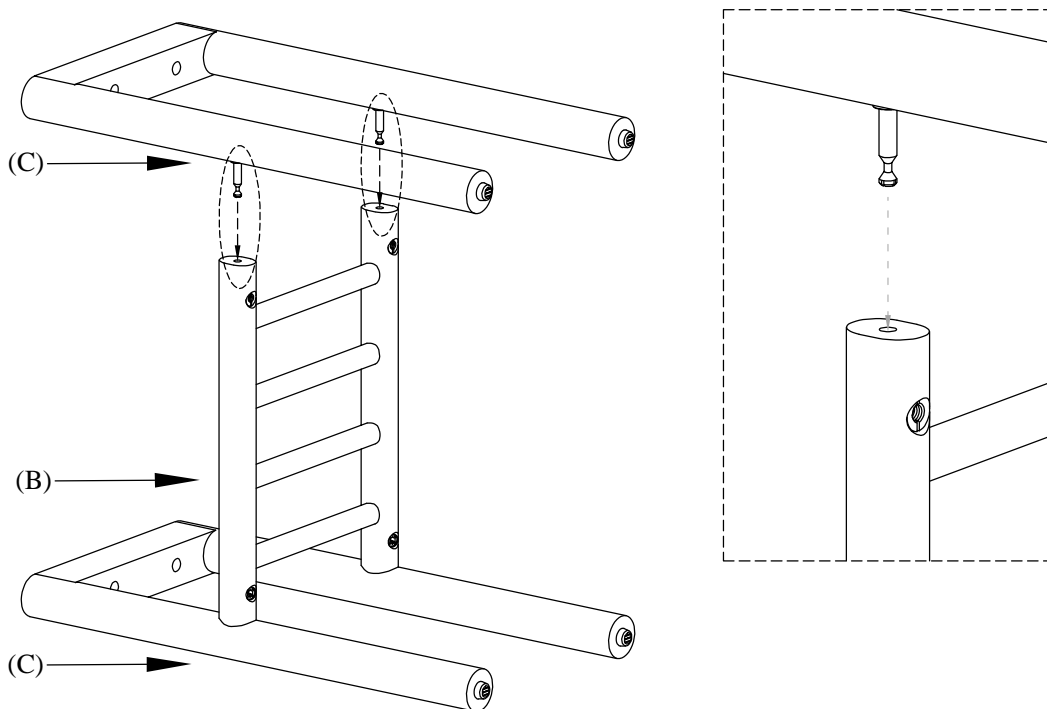

Note: DO NOT TIGHTEN ANY BOLT UNTIL ALL THE BOLTS ARE INSERTED PROPERLY

# SIDE COFFEE TABLE

## STEP 5

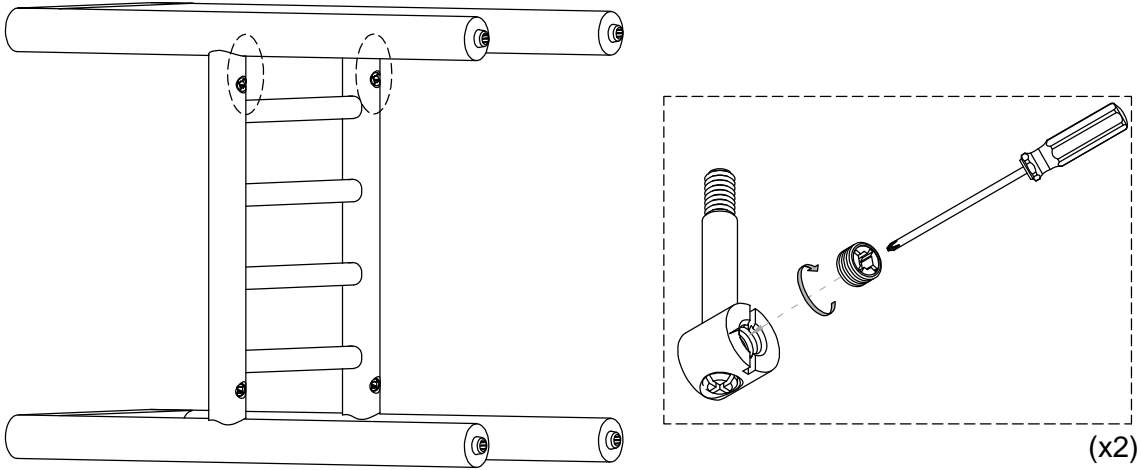

Note: DO NOT TIGHTEN ANY BOLT UNTIL ALL THE BOLTS ARE INSERTED PROPERLY

## STEP 6

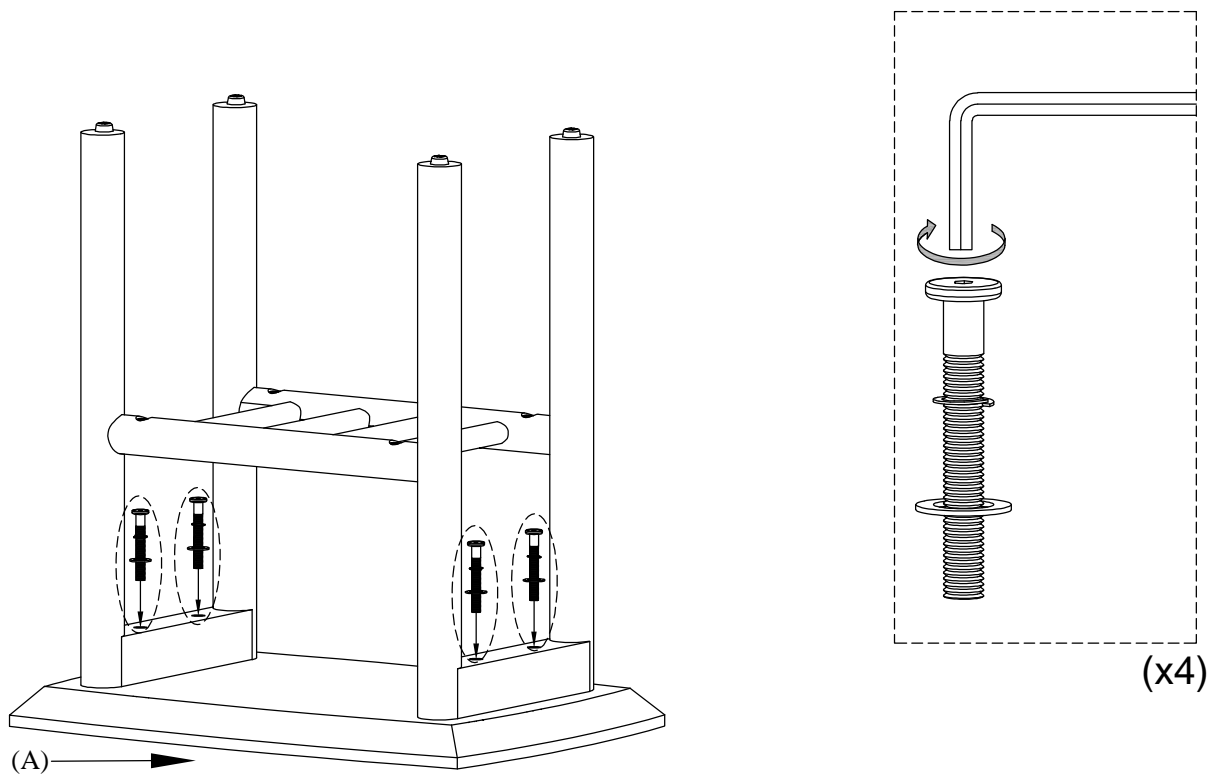

Note: TIGHTEN ALL THE BOLTS

# SIDE COFFEE TABLE

## STEP 7 FINISHED

