

# ASSEMBLY INSTRUCTION

---

## **PLEASE READ BEFORE ASSEMBLING!**

Tip #1: Make sure you've taken all the pieces and hardware out of its packaging before discarding the box.

Tip #2: Using page 2 and/or page 3 of instruction manual make sure all pieces and hardware are accounted for.

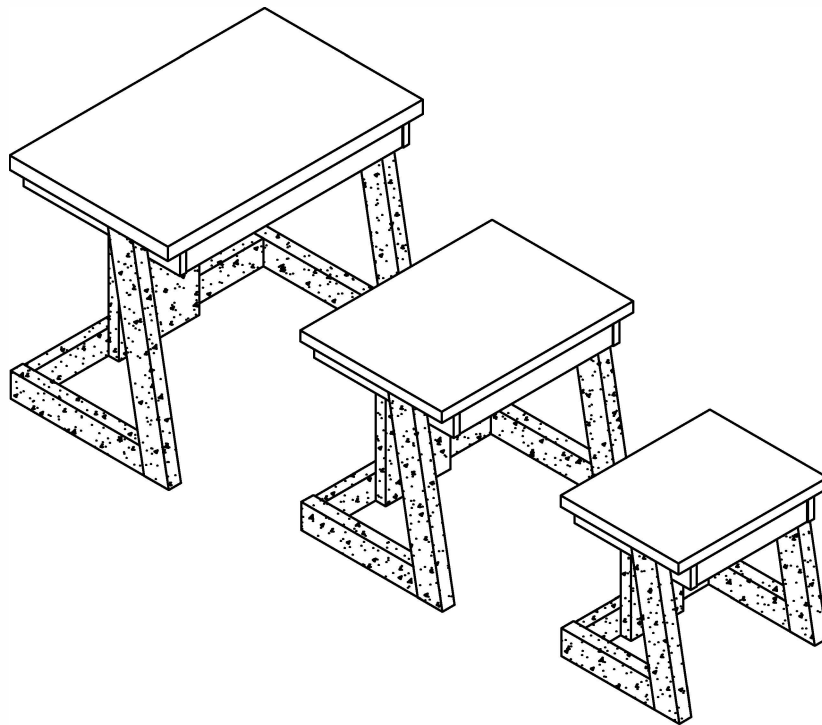





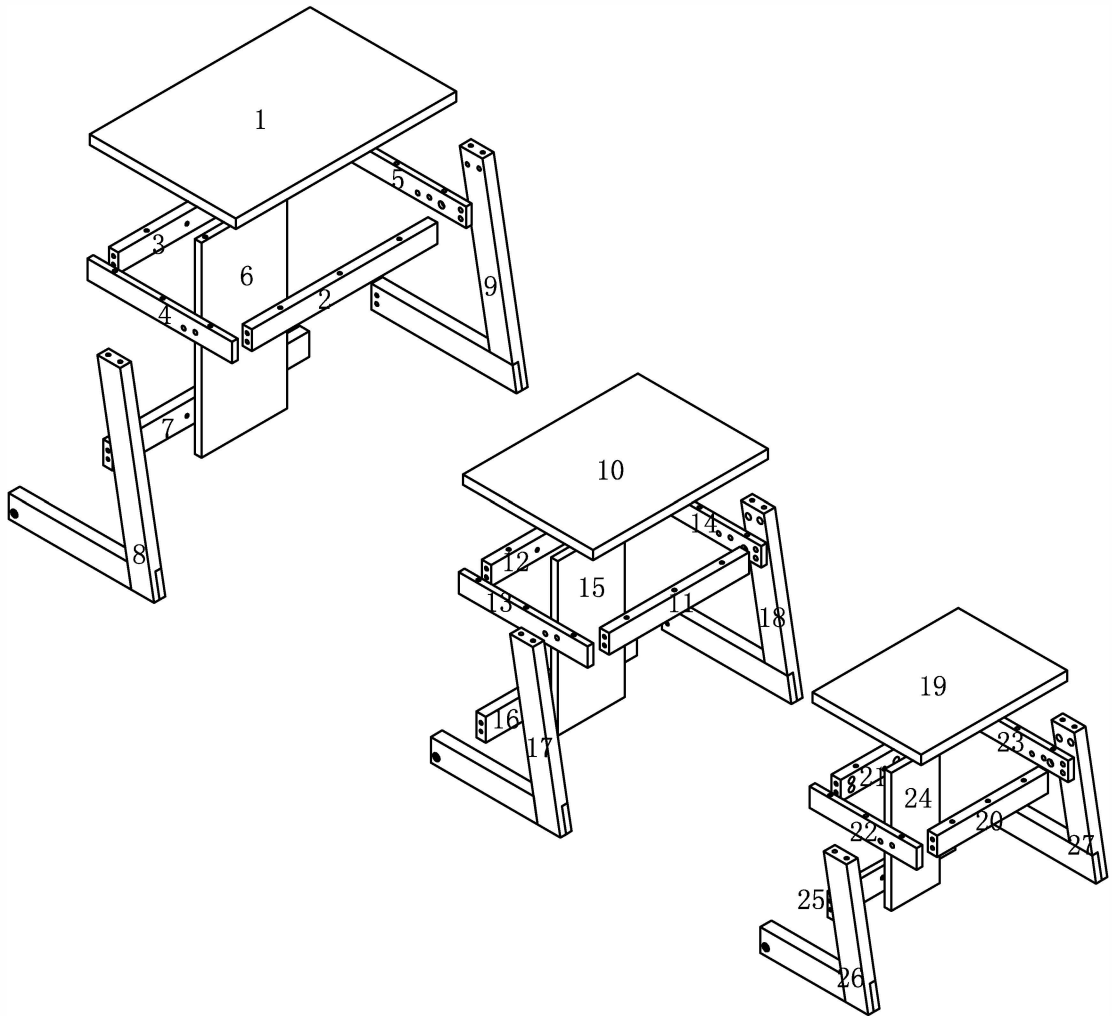







# PARTS IDENTIFICATION

---



(1)	1pc	(8)	1pc	(15)	1pc	(22)	1pc
(2)	1pc	(9)	1pc	(16)	1pc	(23)	1pc
(3)	1pc	(10)	1pc	(17)	1pc	(24)	1pc
(4)	1pc	(11)	1pc	(18)	1pc	(25)	1pc
(5)	1pc	(12)	1pc	(19)	1pc	(26)	1pc
(6)	1pc	(13)	1pc	(20)	1pc	(27)	1pc
(7)	1pc	(14)	1pc	(21)	1pc		

# HARDWARE IDENTIFICATION

A		L29	44PCS
B		Φ 15	44PCS
C		Φ 8x25	34PCS
D		M6x55	6PCS
E		Φ 6x15	6PCS
F		M4	1PC
G		M5	1PC
H		M6x30	12PCS
I		M8x35	12PCS
J		Φ 16	18PCS
K		Φ 22 (WH3)	6PCS
L		Φ 22 (WW)	18PCS
M		Glue: For securing please apply to wood dowel first before inserting into panel	1PC

# HARDWARE IDENTIFICATION

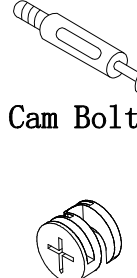
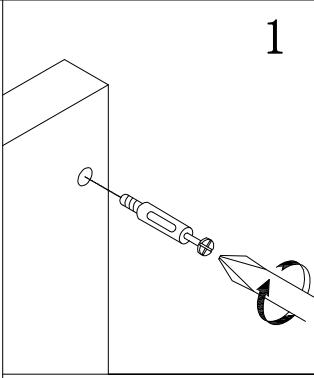
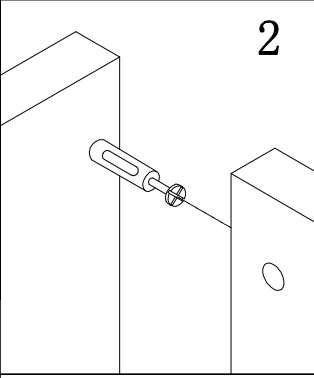
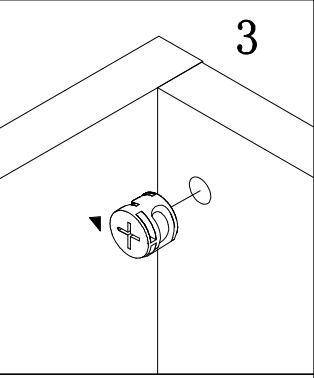
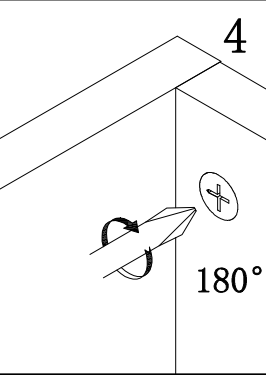
HOW TO	1	2	3	4
 <p>Cam Bolt</p> <p>Cam Lock</p>				 <p>180°</p>
<p>panel.</p>	<p>1. Screw Cam Bolt into panel.</p>	<p>2. Insert Cam Bolt into bolt hole of joining</p>	<p>3. Insert Cam Lock. arrow facing bolt.</p>	<p>4. Gently turn Cam Lock clockwise to lock position.</p>

## STEP 1

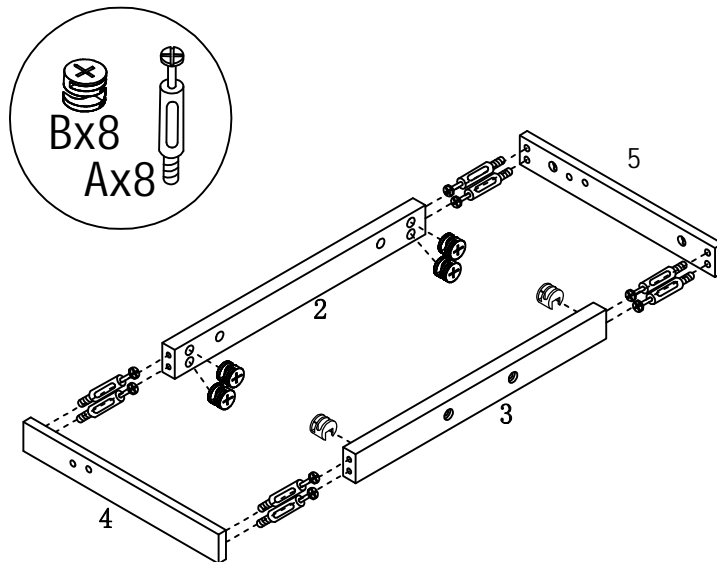

# HARDWARE IDENTIFICATION

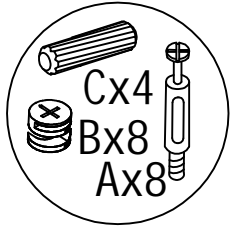
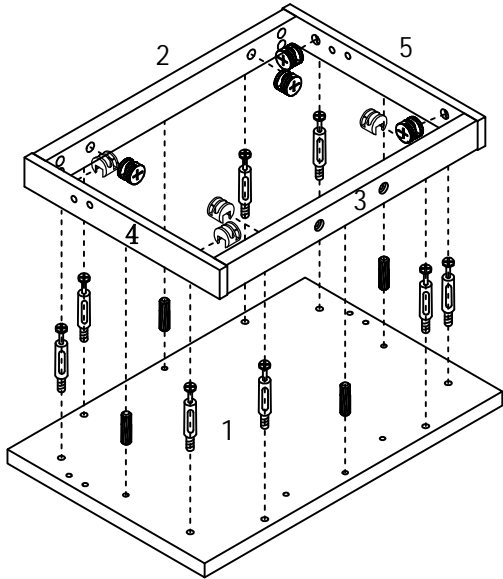

STEP2

STEP3

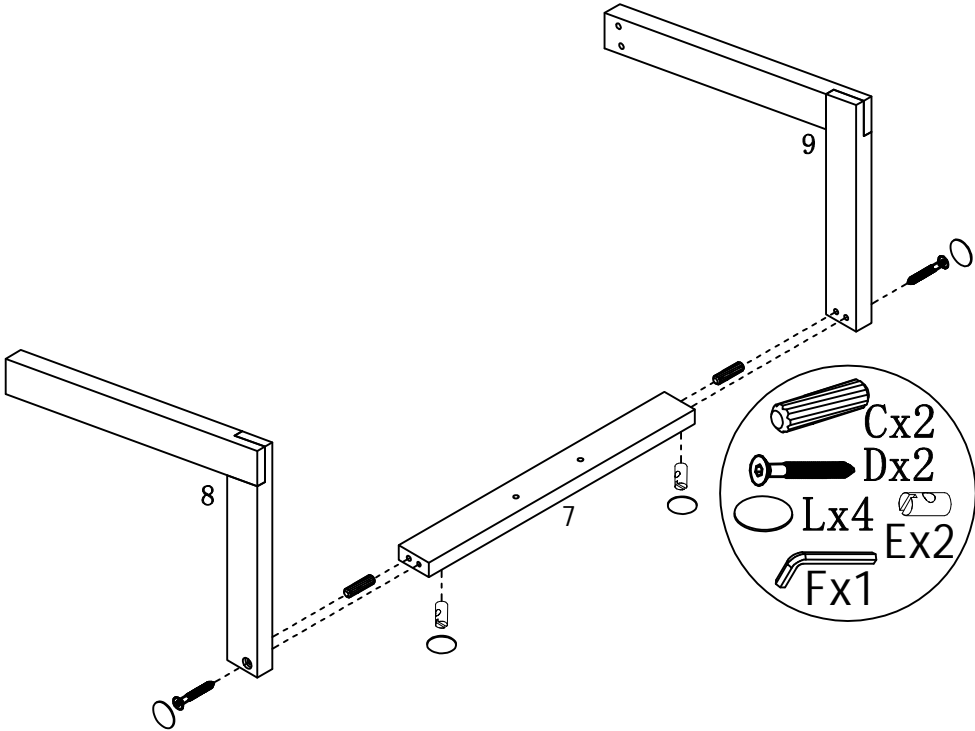

# HARDWARE IDENTIFICATION

---

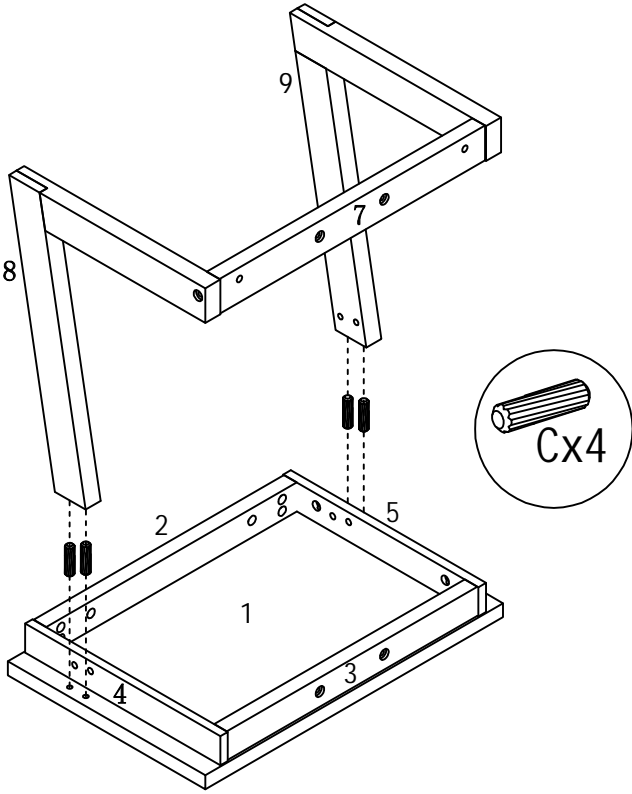

STEP4

STEP5

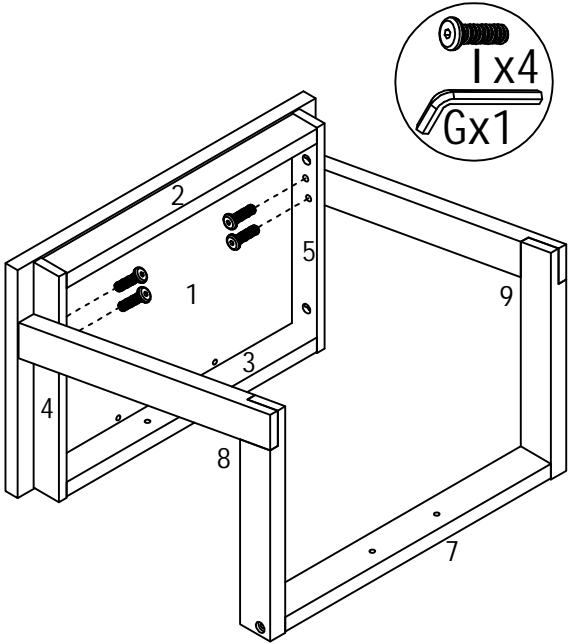

# HARDWARE IDENTIFICATION

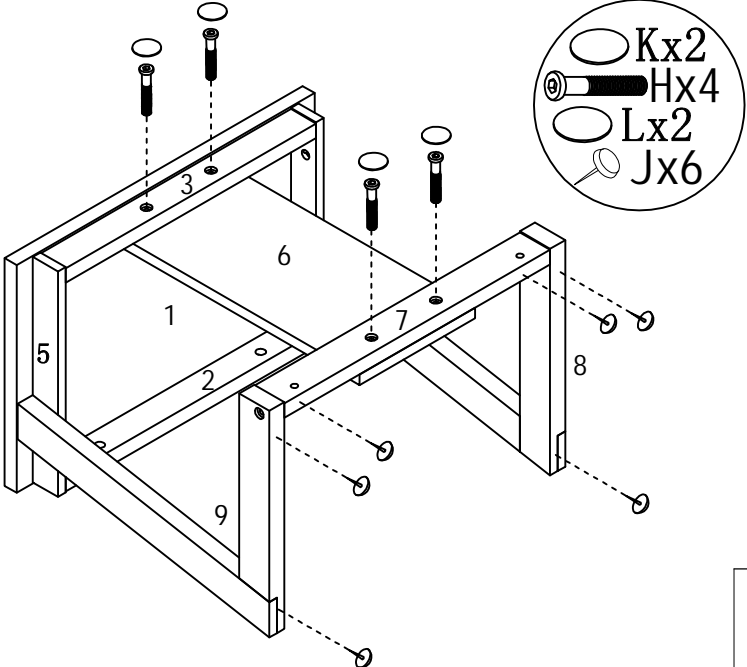

STEP6

STEP7

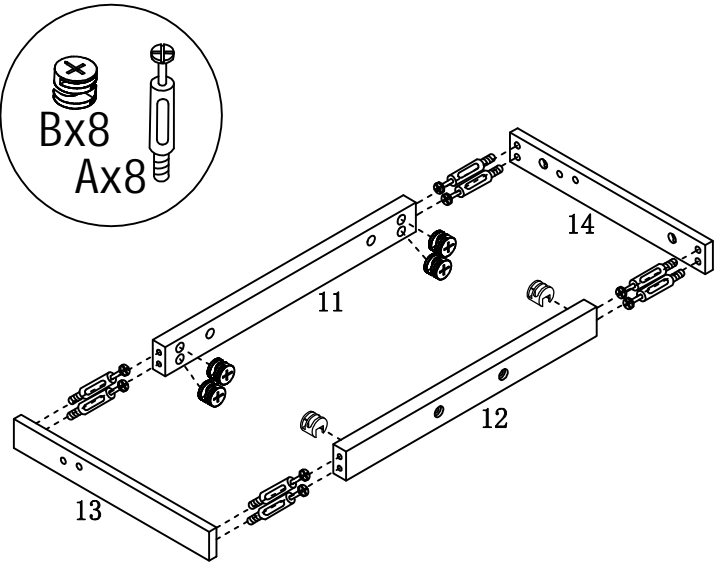

# HARDWARE IDENTIFICATION

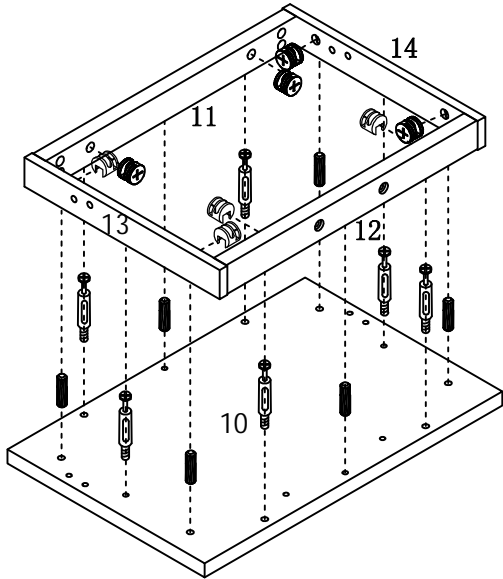

## STEP8

## STEP9

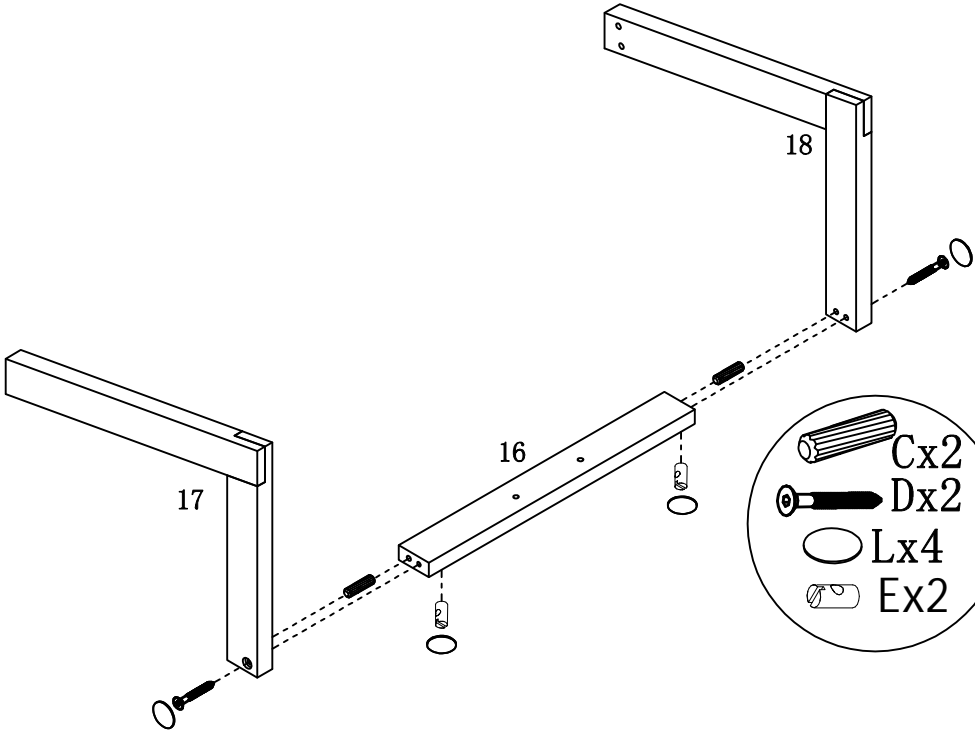

# HARDWARE IDENTIFICATION

---

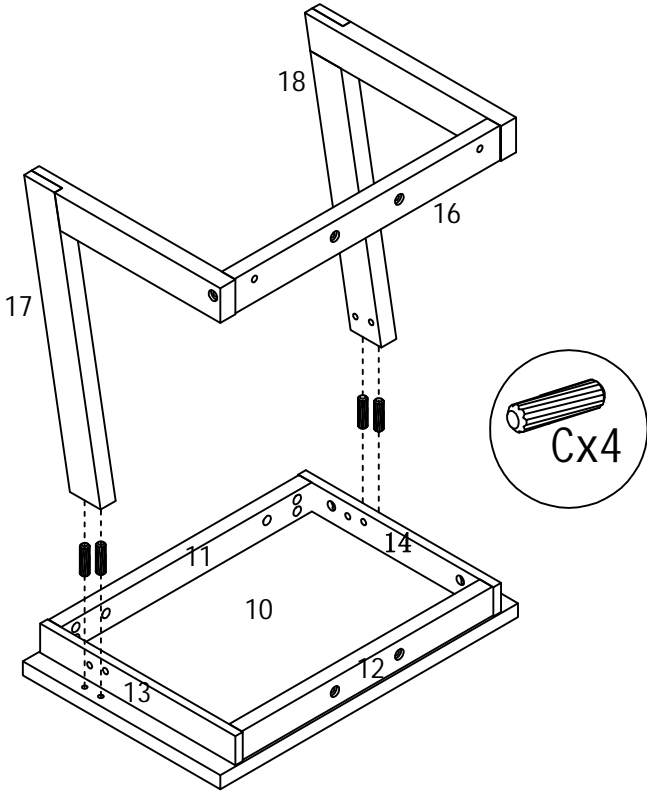

STEP 10

STEP 11

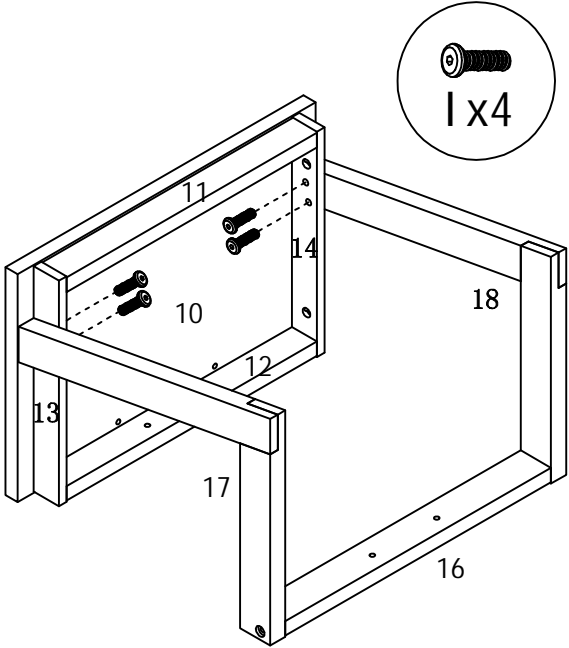

# HARDWARE IDENTIFICATION

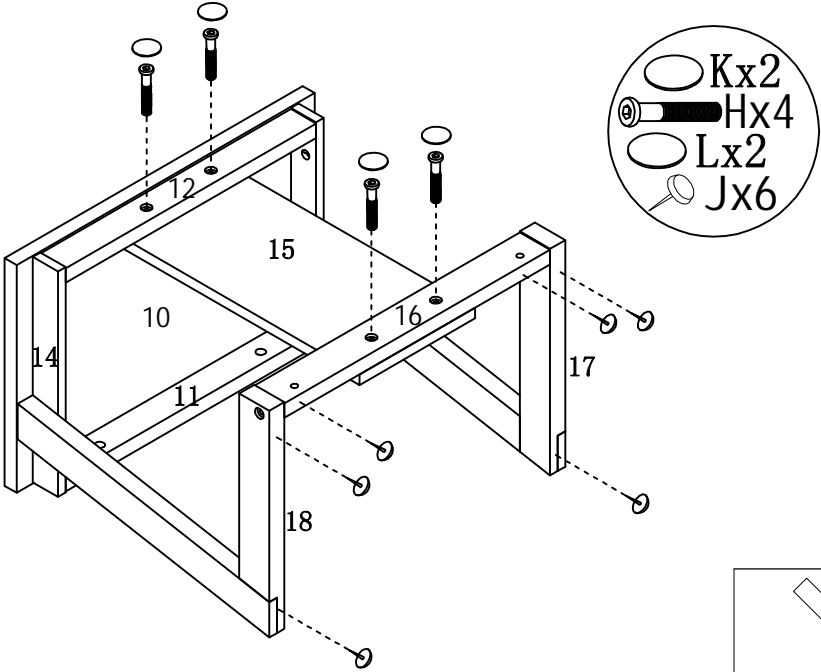

STEP 12

STEP 13

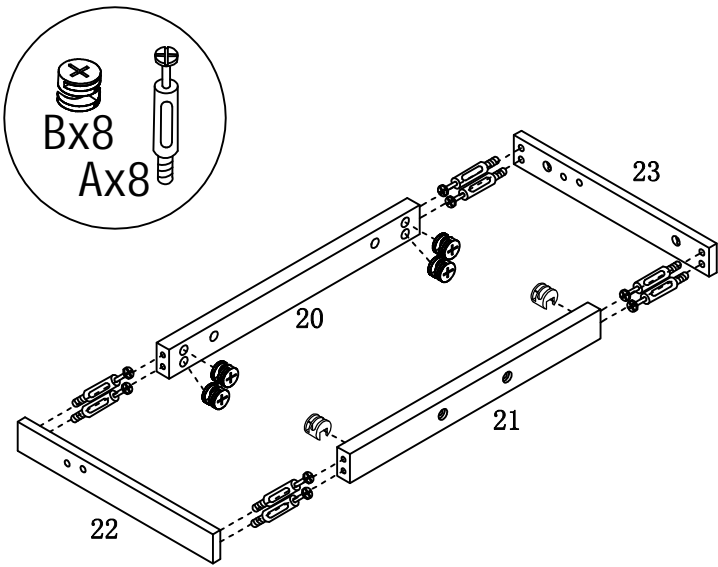

# HARDWARE IDENTIFICATION

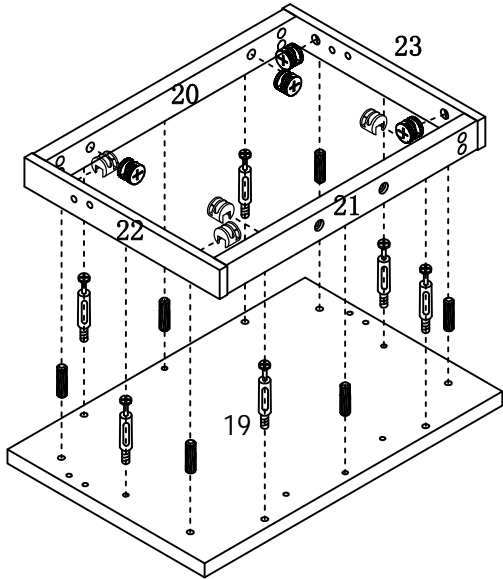

STEP14

STEP15

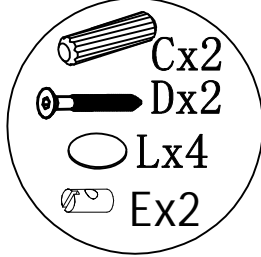
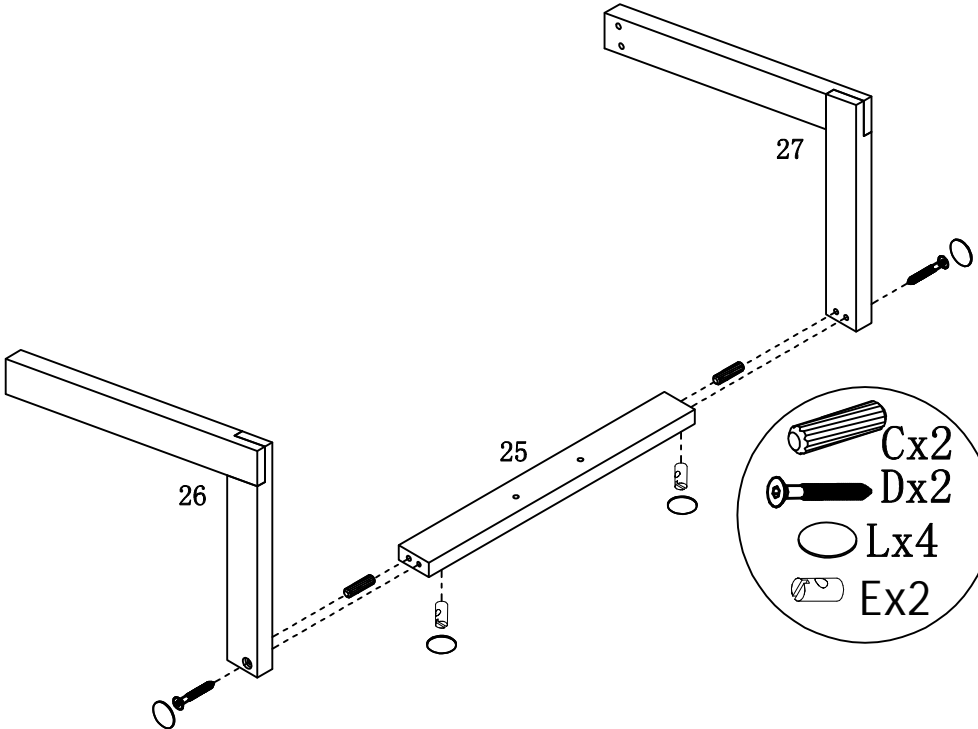

# HARDWARE IDENTIFICATION

---

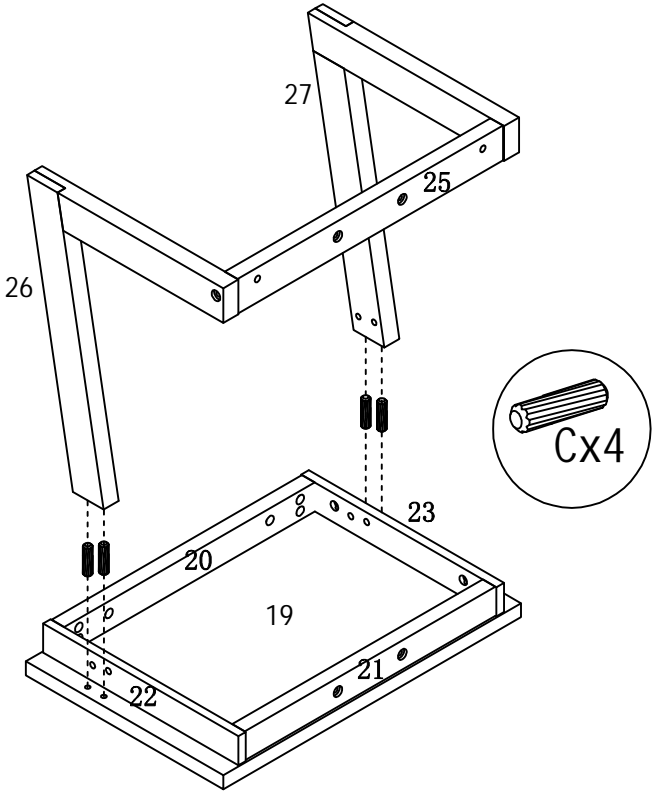

STEP16

STEP17

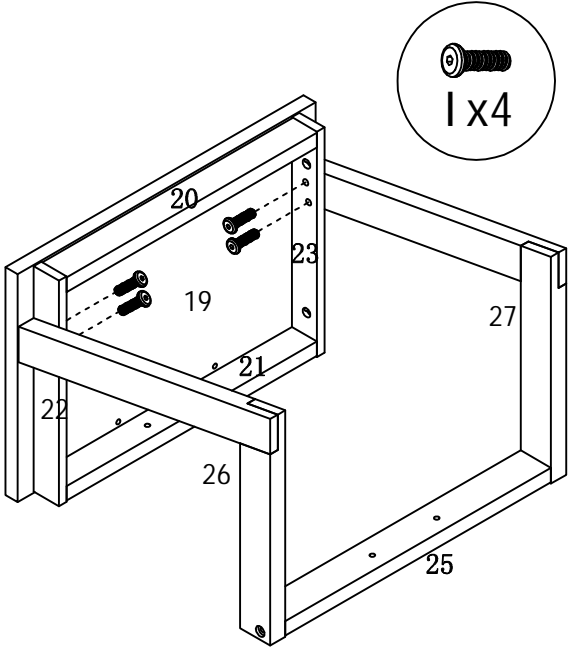

# HARDWARE IDENTIFICATION

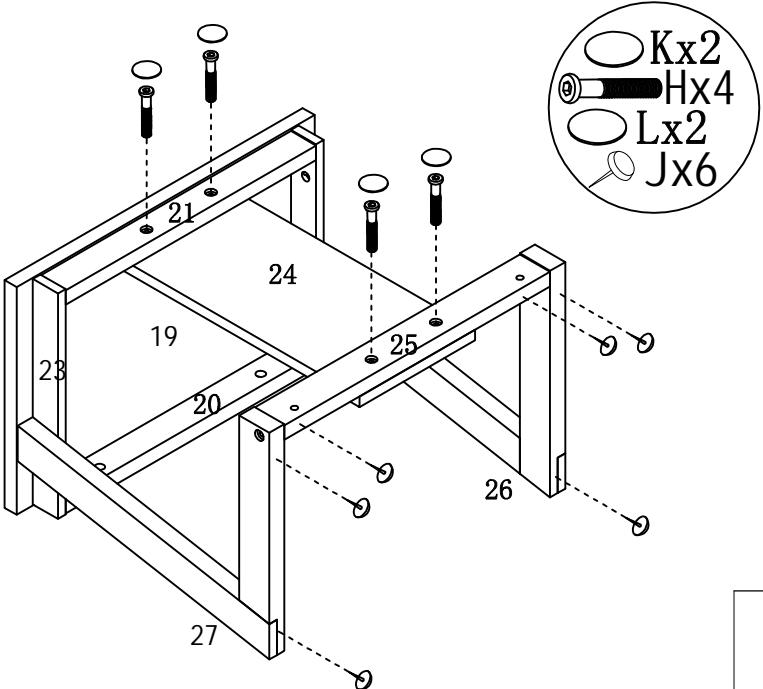

STEP18

STEP19

